

C0402X5R0J102M020BC

TDK Item Description : C0402X5R0J102MT****



Application & Main Feature

Commercial Grade (General (Up to 50V))

Series

C0402 [EIA CC01005]

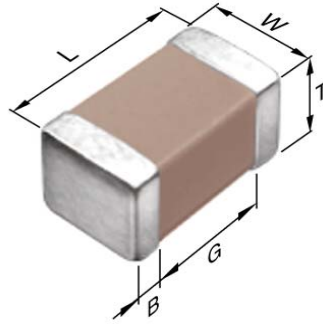

Dimensions

L 0.40mm +/-0.02mm
 W 0.20mm +/-0.02mm
 T 0.20mm +/-0.02mm
 B 0.07mm Min.
 G 0.14mm Min.

Temperature Characteristic

X5R (-55 to 85 degC +/-15%)

Rated Voltage

0J (6.3Vdc)

Capacitance

1nF

Capacitance Tolerance

M (+/-20%)

Dissipation Factor

5% Max.

Insulation Resistance

10Gohm Min.

AEC-Q200

Not Applicable

DC Bias Characteristic

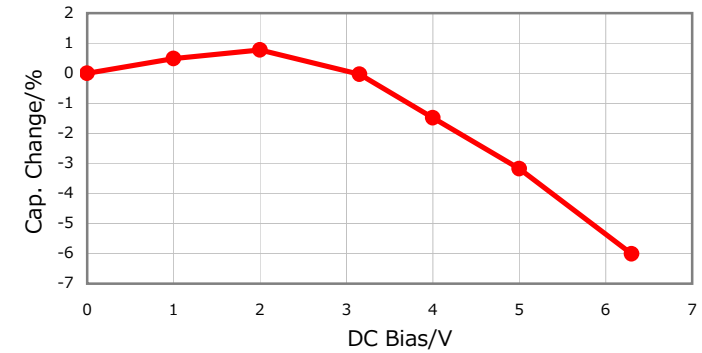

|Z|, ESR vs. Freq. Characteristics

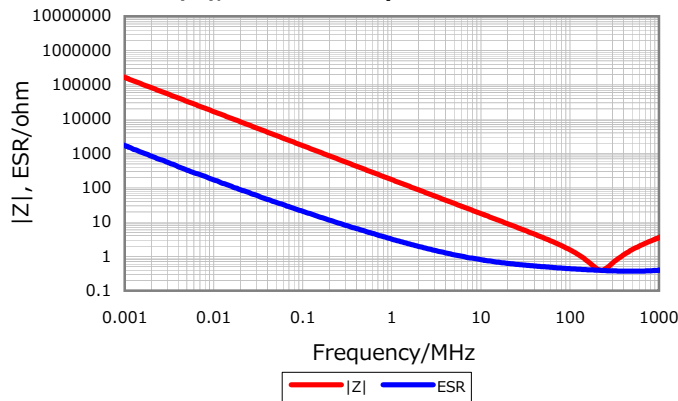

Temperature Characteristic

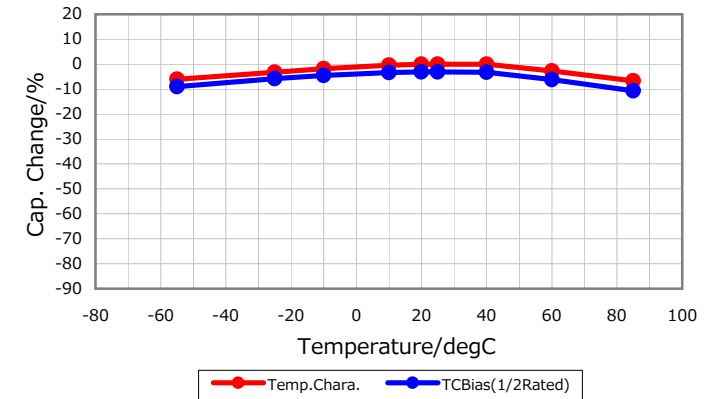

Cap. vs. Freq. Characteristic

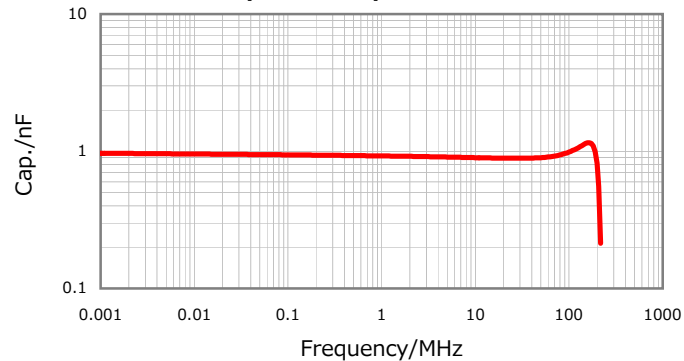

Ripple Temperature Rise Characteristic

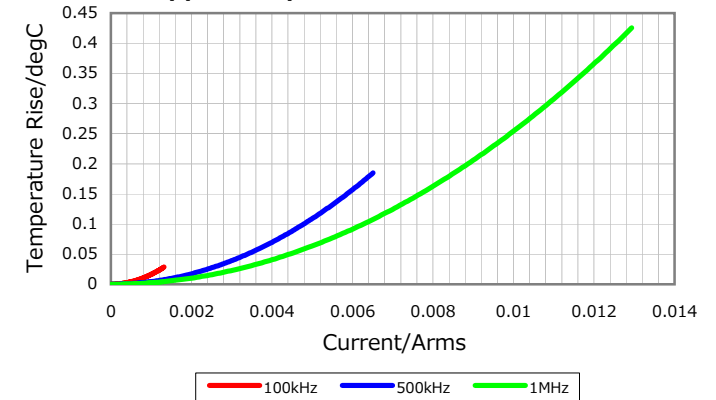

Characterization Sheet (Multilayer Ceramic Chip Capacitors)



All specifications are subject to change without notice.

September 27, 2013