

1 Mbit (64K x16) Multi-Purpose Flash

SST39LF100 / SST39VF100



Data Sheet

FEATURES:

- **Organized as 64K x16**
- **Single Voltage Read and Write Operations**
 - 3.0-3.6V for SST39LF100
 - 2.7-3.6V for SST39VF100
- **Superior Reliability**
 - Endurance: 100,000 Cycles (typical)
 - Greater than 100 years Data Retention
- **Low Power Consumption**
 - Active Current: 20 mA (typical)
 - Standby Current: 3 μ A (typical)
- **Sector-Erase Capability**
 - Uniform 2 KWord sectors
- **Fast Read Access Time**
 - 45 ns for SST39LF100
 - 70 ns for SST39VF100
- **Latched Address and Data**
- **Fast Erase and Word-Program**
 - Sector-Erase Time: 18 ms (typical)
 - Chip-Erase Time: 70 ms (typical)
 - Word-Program Time: 14 μ s (typical)
 - Chip Rewrite Time: 1 second (typical)
- **Automatic Write Timing**
 - Internal V_{PP} Generation
- **End-of-Write Detection**
 - Toggle Bit
 - Data# Polling
- **CMOS I/O Compatibility**
- **JEDEC Standard Command Sets**
- **Packages Available**
 - 40-lead TSOP (10mm x 14mm)
 - 48-ball TFBGA (6mm x 8mm)

PRODUCT DESCRIPTION

The SST39LF/VF100 devices are 64K x16 CMOS Multi-Purpose Flash (MPF) manufactured with SST's proprietary, high performance CMOS SuperFlash technology. The split-gate cell design and thick oxide tunneling injector attain better reliability and manufacturability compared with alternate approaches. The SST39LF100 and SST39VF100 write (Program or Erase) with a single voltage power supply of 3.0-3.6V and 2.7-3.6V, respectively.

Featuring high performance Word-Program, the SST39LF/VF100 devices provide a typical Word-Program time of 14 μ sec. The devices use Toggle Bit or Data# Polling to detect the completion of the Program or Erase operation. To protect against inadvertent write, the SST39LF/VF100 have on-chip hardware and software data protection schemes. Designed, manufactured, and tested for a wide spectrum of applications, the SST39LF/VF100 are offered with a guaranteed endurance of 10,000 cycles. Data retention is rated at greater than 100 years.

The SST39LF/VF100 devices are suited for applications that require convenient and economical updating of program, configuration, or data memory. For all system applications, the SST39LF/VF100 significantly improve performance and reliability, while lowering power consumption. The SST39LF/VF100 inherently use less energy during Erase and Program than alternative flash technologies. The total energy consumed is a function of the applied voltage, current, and time of application. Since for any given voltage range, the SuperFlash technology uses less current to program and has a shorter erase time, the total

energy consumed during any Erase or Program operation is less than alternative flash technologies. The SST39LF/VF100 also improve flexibility while lowering the cost for program, data, and configuration storage applications.

The SuperFlash technology provides fixed Erase and Program times, independent of the number of Erase/Program cycles that have occurred. Therefore the system software or hardware does not have to be modified or de-rated as is necessary with alternative flash technologies, whose Erase and Program times increase with accumulated Erase/Program cycles.

To meet surface mount requirements, the SST39LF/VF100 are offered in 40-lead TSOP and 48-ball TFBGA packages. See Figure 1 for pinout.

Device Operation

Commands are used to initiate the memory operation functions of the device. Commands are written to the device using standard microprocessor write sequences. A command is written by asserting WE# low while keeping CE# low. The address bus is latched on the falling edge of WE# or CE#, whichever occurs last. The data bus is latched on the rising edge of WE# or CE#, whichever occurs first.



Read

The Read operation of the SST39LF/VF100 is controlled by CE# and OE#, both have to be low for the system to obtain data from the outputs. CE# is used for device selection. When CE# is high, the chip is deselected and only standby power is consumed. OE# is the output control and is used to gate data from the output pins. The data bus is in high impedance state when either CE# or OE# is high. Refer to the Read cycle timing diagram for further details (Figure 2).

Word-Program Operation

The SST39LF/VF100 are programmed on a word-by-word basis. Before programming, one must ensure that the sector in which the word is programmed is erased. The Program operation consists of three steps. The first step is the three-byte load sequence for Software Data Protection. The second step is to load word address and word data. During the Word-Program operation, the addresses are latched on the falling edge of either CE# or WE#, whichever occurs last. The data is latched on the rising edge of either CE# or WE#, whichever occurs first. The third step is the internal Program operation which is initiated after the rising edge of the fourth WE# or CE#, whichever occurs first. The Program operation, once initiated, will be completed within 20 μ s. See Figures 3 and 4 for WE# and CE# controlled Program operation timing diagrams and Figure 13 for flowcharts. During the Program operation, the only valid reads are Data# Polling and Toggle Bit. During the internal Program operation, the host is free to perform additional tasks. Any commands issued during the internal Program operation are ignored.

Sector-Erase Operation

The Sector-Erase operation allows the system to erase the device on a sector-by-sector basis. The sector architecture is based on uniform sector size of 2 KWord. The Sector-Erase operation is initiated by executing a six-byte command sequence with Sector-Erase command (30H) and sector address (SA) in the last bus cycle. The address lines A₁₁-A₁₅ are used to determine the sector address. The sector address is latched on the falling edge of the sixth WE# pulse, while the command (30H) is latched on the rising edge of the sixth WE# pulse. The internal Erase operation begins after the sixth WE# pulse. The End-of-Erase operation can be determined using either Data# Polling or Toggle Bit methods. See Figure 8 for timing waveforms. Any commands issued during the Sector-Erase operation are ignored.

Chip-Erase Operation

The SST39LF/VF100 provide a Chip-Erase operation, which allows the user to erase the entire memory array to the "1" state. This is useful when the entire device must be quickly erased.

The Chip-Erase operation is initiated by executing a six-byte command sequence with Chip-Erase command (10H) at address 5555H in the last byte sequence. The Erase operation begins with the rising edge of the sixth WE# or CE#, whichever occurs first. During the Erase operation, the only valid read is Toggle Bit or Data# Polling. See Table 4 for the command sequence, Figure 7 for timing diagram, and Figure 16 for the flowchart. Any commands issued during the Chip-Erase operation are ignored.

Write Operation Status Detection

The SST39LF/VF100 provide two software means to detect the completion of a Write (Program or Erase) cycle, in order to optimize the system write cycle time. The software detection includes two status bits: Data# Polling (DQ₇) and Toggle Bit (DQ₆). The End-of-Write detection mode is enabled after the rising edge of WE#, which initiates the internal program or erase operation.

The actual completion of the nonvolatile write is asynchronous with the system; therefore, either a Data# Polling or Toggle Bit read may be simultaneous with the completion of the write cycle. If this occurs, the system may possibly get an erroneous result, i.e., valid data may appear to conflict with either DQ₇ or DQ₆. In order to prevent spurious rejection, if an erroneous result occurs, the software routine should include a loop to read the accessed location an additional two (2) times. If both reads are valid, then the device has completed the Write cycle, otherwise the rejection is valid.

Data# Polling (DQ₇)

When the SST39LF/VF100 are in the internal Program operation, any attempt to read DQ₇ will produce the complement of the true data. Once the Program operation is completed, DQ₇ will produce true data. The device is then ready for the next operation. During internal Erase operation, any attempt to read DQ₇ will produce a '0'. Once the internal Erase operation is completed, DQ₇ will produce a '1'. The Data# Polling is valid after the rising edge of fourth WE# (or CE#) pulse for Program operation. For Sector- or Chip-Erase, the Data# Polling is valid after the rising edge of sixth WE# (or CE#) pulse. See Figure 5 for Data# Polling timing diagram and Figure 14 for a flowchart.



1 Mbit Multi-Purpose Flash SST39LF100 / SST39VF100

Data Sheet

Toggle Bit (DQ₆)

During the internal Program or Erase operation, any consecutive attempts to read DQ₆ will produce alternating 1s and 0s, i.e., toggling between 1 and 0. When the internal Program or Erase operation is completed, the DQ₆ bit will stop toggling. The device is then ready for the next operation. The Toggle Bit is valid after the rising edge of fourth WE# (or CE#) pulse for Program operation. For Sector- or Chip-Erase, the Toggle Bit is valid after the rising edge of sixth WE# (or CE#) pulse. See Figure 6 for Toggle Bit timing diagram and Figure 14 for a flowchart.

Data Protection

The SST39LF/VF100 provide both hardware and software features to protect nonvolatile data from inadvertent writes.

Hardware Data Protection

Noise/Glitch Protection: A WE# or CE# pulse of less than 5 ns will not initiate a Write cycle.

V_{DD} Power Up/Down Detection: The Write operation is inhibited when V_{DD} is less than 1.5V.

Write Inhibit Mode: Forcing OE# low, CE# high, or WE# high will inhibit the Write operation. This prevents inadvertent Writes during power-up or power-down.

Software Data Protection (SDP)

The SST39LF/VF100 provide the JEDEC approved Software Data Protection scheme for all data alteration operations, i.e., Program and Erase. Any Program operation requires the inclusion of the three-byte sequence. The three-byte load sequence is used to initiate the Program operation, providing optimal protection from inadvertent Write operations, e.g., during the system power-up or power-down. Any Erase operation requires the inclusion of six-byte sequence. The SST39LF/VF100 devices are shipped with the Software Data Protection permanently enabled. See Table 4 for the specific software command codes. During SDP command sequence, invalid commands will abort the device to Read mode within T_{RC}. The contents of DQ₁₅-DQ₈ are “Don’t Care” during any SDP command sequence.

Product Identification

The Product Identification mode identifies the devices as SST39LF100 and SST39VF100 and manufacturer as SST. This mode may be accessed by software operations. Users may use the Software Product Identification operation to identify the part (i.e., using the device ID) when using multiple manufacturers in the same socket. For details, see

Table 4 for software operation, Figure 9 for the Software ID Entry and Read timing diagram, and Figure 15 for the Software ID Entry command sequence flowchart.

TABLE 1: PRODUCT IDENTIFICATION

	Address	Data
Manufacturer's ID	0000H	00BFH
Device ID SST39LF/VF100	0001H	2788H

T1.3 363

Product Identification Mode Exit/ CFI Mode Exit

In order to return to the standard Read mode, the Software Product Identification mode must be exited. Exit is accomplished by issuing the Software ID Exit command sequence, which returns the device to the Read mode. This command may also be used to reset the device to the Read mode after any inadvertent transient condition that apparently causes the device to behave abnormally, e.g., not read correctly. Please note that the Software ID Exit/CFI Exit command is ignored during an internal Program or Erase operation. See Table 4 for software command codes, Figure 10 for timing waveform and Figure 15 for a flowchart.



1 Mbit Multi-Purpose Flash SST39LF100 / SST39VF100

Data Sheet

FUNCTIONAL BLOCK DIAGRAM

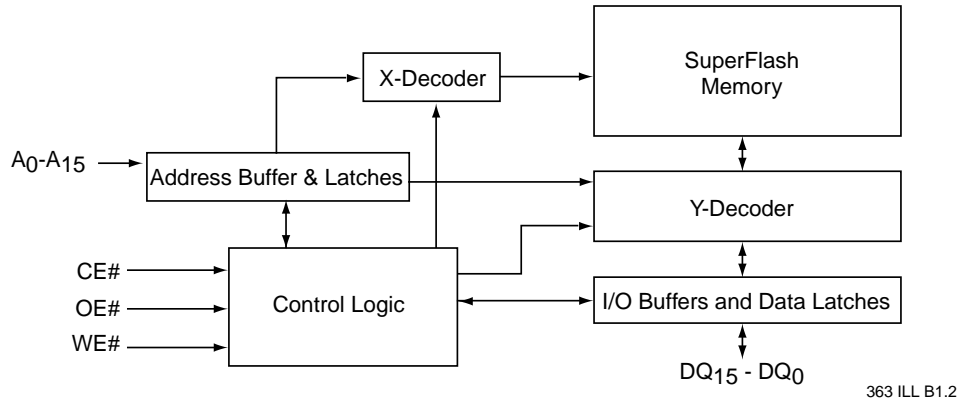

SST39LF100/SST39VF100

TOP VIEW (balls facing down)

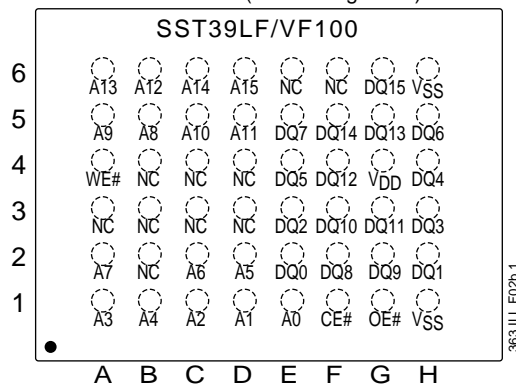

FIGURE 1: PIN ASSIGNMENTS FOR 40-LEAD TSOP AND 48-BALL TFBGA



TABLE 4: SOFTWARE COMMAND SEQUENCE

Command Sequence	1st Bus Write Cycle		2nd Bus Write Cycle		3rd Bus Write Cycle		4th Bus Write Cycle		5th Bus Write Cycle		6th Bus Write Cycle	
	Addr ¹	Data ²	Addr ¹	Data ²	Addr ¹	Data ²	Addr ¹	Data ²	Addr ¹	Data ²	Addr ¹	Data ²
Word-Program	5555H	AAH	2AAAH	55H	5555H	A0H	WA ³	Data				
Sector-Erase	5555H	AAH	2AAAH	55H	5555H	80H	5555H	AAH	2AAAH	55H	SA _X ⁴	30H
Chip-Erase	5555H	AAH	2AAAH	55H	5555H	80H	5555H	AAH	2AAAH	55H	5555H	10H
Software ID Entry ^{5,6}	5555H	AAH	2AAAH	55H	5555H	90H						
Software ID Exit ⁷	XXH	F0H										
Software ID Exit ⁷	5555H	AAH	2AAAH	55H	5555H	F0H						

T4.4 363

1. Address format A₁₄-A₀ (Hex), Addresses A₁₅ can be V_{IL} or V_{IH}, but no other value, for the Command sequence
2. DQ₁₅ - DQ₈ can be V_{IL} or V_{IH}, but no other value, for the Command sequence
3. WA = Program word address
4. SA_X for Sector-Erase; uses A₁₅-A₁₁ address lines
5. The device does not remain in Software Product ID Mode if powered down.
6. With A₁₅-A₁ = 0; SST Manufacturer's ID= 00BFH, is read with A₀ = 0,
SST39LF100/SST39VF100 Device ID = 2788H, is read with A₀ = 1
7. Both Software ID Exit operations are equivalent

Absolute Maximum Stress Ratings (Applied conditions greater than those listed under “Absolute Maximum Stress Ratings” may cause permanent damage to the device. This is a stress rating only and functional operation of the device at these conditions or conditions greater than those defined in the operational sections of this data sheet is not implied. Exposure to absolute maximum stress rating conditions may affect device reliability.)

Temperature Under Bias	-55°C to +125°C
Storage Temperature	-65°C to +150°C
D. C. Voltage on Any Pin to Ground Potential	-0.5V to V _{DD} + 0.5V
Transient Voltage (<20 ns) on Any Pin to Ground Potential	-1.0V to V _{DD} + 1.0V
Voltage on A ₉ Pin to Ground Potential	-0.5V to 13.2V
Package Power Dissipation Capability (Ta = 25°C)	1.0W
Surface Mount Lead Soldering Temperature (3 Seconds)	240°C
Output Short Circuit Current ¹	50 mA

1. Outputs shorted for no more than one second. No more than one output shorted at a time.

OPERATING RANGE: SST39LF100

Range	Ambient Temp	V _{DD}
Commercial	0°C to +70°C	3.0-3.6V

OPERATING RANGE: SST39VF100

Range	Ambient Temp	V _{DD}
Commercial	0°C to +70°C	2.7-3.6V
Industrial	-40°C to +85°C	2.7-3.6V

AC CONDITIONS OF TEST

Input Rise/Fall Time	5 ns
Output Load	C _L = 30 pF for SST39LF100
Output Load	C _L = 100 pF for SST39VF100
See Figures 11 and 12	



1 Mbit Multi-Purpose Flash SST39LF100 / SST39VF100

Data Sheet

TABLE 5: DC OPERATING CHARACTERISTICS $V_{DD} = 3.0-3.6V$ FOR SST39LF100 AND $2.7-3.6V$ FOR SST39VF100

Symbol	Parameter	Limits			Test Conditions
		Min	Max	Units	
I_{DD}	Power Supply Current				Address input = V_{IL}/V_{IH} , at $f=1/T_{RC}$ Min., $V_{DD}=V_{DD}$ Max.
	Read		30	mA	$CE\#=OE\#=V_{IL}, WE\#=V_{IH}$, all I/Os open
	Program and Erase		30	mA	$CE\#=WE\#=V_{IL}, OE\#=V_{IH}$
I_{SB}	Standby V_{DD} Current		20	μA	$CE\#=V_{IHC}, V_{DD} = V_{DD}$ Max.
I_{LI}	Input Leakage Current		1	μA	$V_{IN} = GND$ to $V_{DD}, V_{DD} = V_{DD}$ Max.
I_{LO}	Output Leakage Current		10	μA	$V_{OUT} = GND$ to $V_{DD}, V_{DD} = V_{DD}$ Max.
V_{IL}	Input Low Voltage		0.8		$V_{DD} = V_{DD}$ Min.
V_{IH}	Input High Voltage	$0.7V_{DD}$		V	$V_{DD} = V_{DD}$ Max.
V_{IHC}	Input High Voltage (CMOS)	$V_{DD}-0.3$		V	$V_{DD} = V_{DD}$ Max.
V_{OL}	Output Low Voltage		0.2	V	$I_{OL} = 5.8$ mA, $V_{DD} = V_{DD}$ Min.
V_{OH}	Output High Voltage	$V_{DD}-0.2$		V	$I_{OH} = -100$ μA , $V_{DD} = V_{DD}$ Min.

T5.5 363

TABLE 6: RECOMMENDED SYSTEM POWER-UP TIMINGS

Symbol	Parameter	Minimum	Units
$T_{PU-READ}^1$	Power-up to Read Operation	100	μs
$T_{PU-WRITE}^1$	Power-up to Program/Erase Operation	100	μs

T6.0 363

1. This parameter is measured only for initial qualification and after a design or process change that could affect this parameter.

TABLE 7: CAPACITANCE ($T_a = 25^\circ C, f=1$ Mhz, other pins open)

Parameter	Description	Test Condition	Maximum
$C_{I/O}^1$	I/O Pin Capacitance	$V_{I/O} = 0V$	12 pF
C_{IN}^1	Input Capacitance	$V_{IN} = 0V$	6 pF

T7.0 363

1. This parameter is measured only for initial qualification and after a design or process change that could affect this parameter.

TABLE 8: RELIABILITY CHARACTERISTICS

Symbol	Parameter	Minimum Specification	Units	Test Method
N_{END}^1	Endurance	10,000	Cycles	JEDEC Standard A117
T_{DR}^1	Data Retention	100	Years	JEDEC Standard A103
I_{LTH}^1	Latch Up	$100 + I_{DD}$	mA	JEDEC Standard 78

T8.1 363

1. This parameter is measured only for initial qualification and after a design or process change that could affect this parameter.



AC CHARACTERISTICS

TABLE 9: READ CYCLE TIMING PARAMETERS $V_{DD} = 3.0-3.6V$ FOR SST39LF100 AND $2.7-3.6V$ FOR SST39VF100

Symbol	Parameter	SST39LF100-35		SST39VF100-70		Units
		Min	Max	Min	Max	
T_{RC}	Read Cycle Time	45		70		ns
T_{CE}	Chip Enable Access Time		45		70	ns
T_{AA}	Address Access Time		45		70	ns
T_{OE}	Output Enable Access Time		20		35	ns
T_{CLZ}^1	CE# Low to Active Output	0		0		ns
T_{OLZ}^1	OE# Low to Active Output	0		0		ns
T_{CHZ}^1	CE# High to High-Z Output		15		20	ns
T_{OHZ}^1	OE# High to High-Z Output		15		20	ns
T_{OH}^1	Output Hold from Address Change	0		0		ns

T9.3 363

1. This parameter is measured only for initial qualification and after a design or process change that could affect this parameter.

TABLE 10: PROGRAM/ERASE CYCLE TIMING PARAMETERS

Symbol	Parameter	Min	Max	Units
T_{BP}	Word-Program Time		20	μs
T_{AS}	Address Setup Time	0		ns
T_{AH}	Address Hold Time	30		ns
T_{CS}	WE# and CE# Setup Time	0		ns
T_{CH}	WE# and CE# Hold Time	0		ns
T_{OES}	OE# High Setup Time	0		ns
T_{OEH}	OE# High Hold Time	10		ns
T_{CP}	CE# Pulse Width	40		ns
T_{WP}	WE# Pulse Width	40		ns
T_{WPH}^1	WE# Pulse Width High	30		ns
T_{CPH}^1	CE# Pulse Width High	30		ns
T_{DS}	Data Setup Time	30		ns
T_{DH}^1	Data Hold Time	0		ns
T_{IDA}^1	Software ID Access and Exit Time		150	ns
T_{SE}	Sector-Erase		25	ms
T_{BE}	Block-Erase		25	ms
T_{SCE}	Chip-Erase		100	ms

T10.1 363

1. This parameter is measured only for initial qualification and after a design or process change that could affect this parameter.

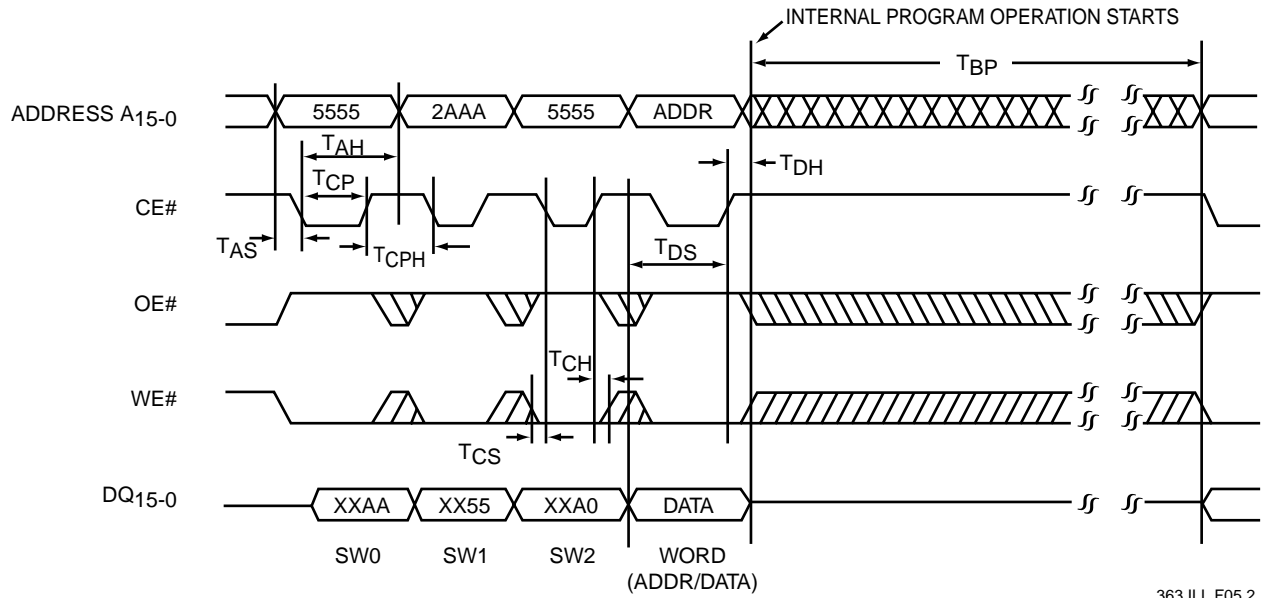

Note: X can be V_{IL} or V_{IH}, but no other value

FIGURE 4: CE# CONTROLLED PROGRAM CYCLE TIMING DIAGRAM

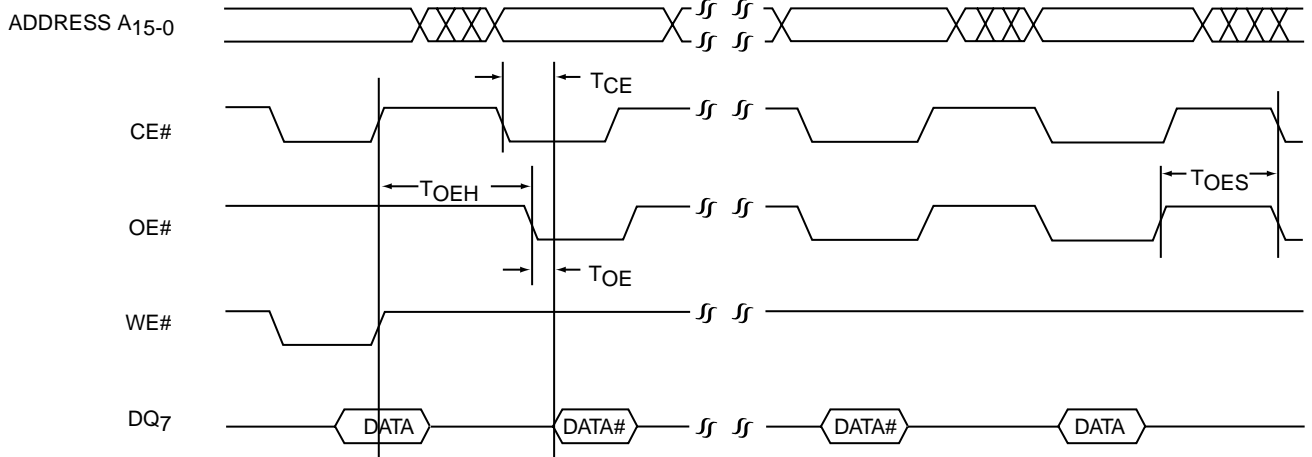

FIGURE 5: DATA# POLLING TIMING DIAGRAM



1 Mbit Multi-Purpose Flash SST39LF100 / SST39VF100

Data Sheet

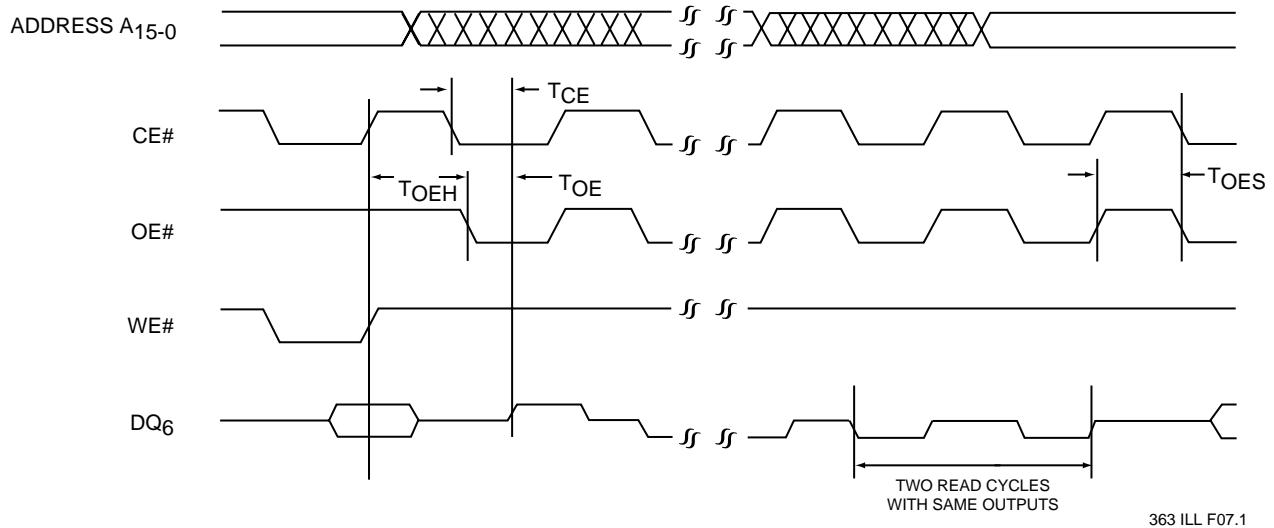
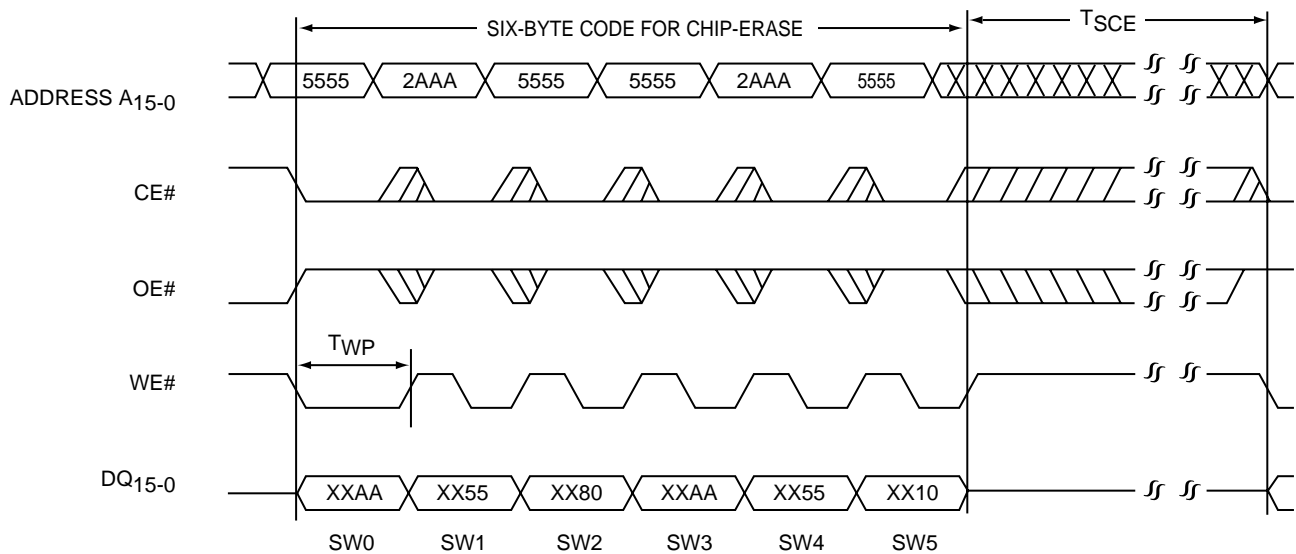
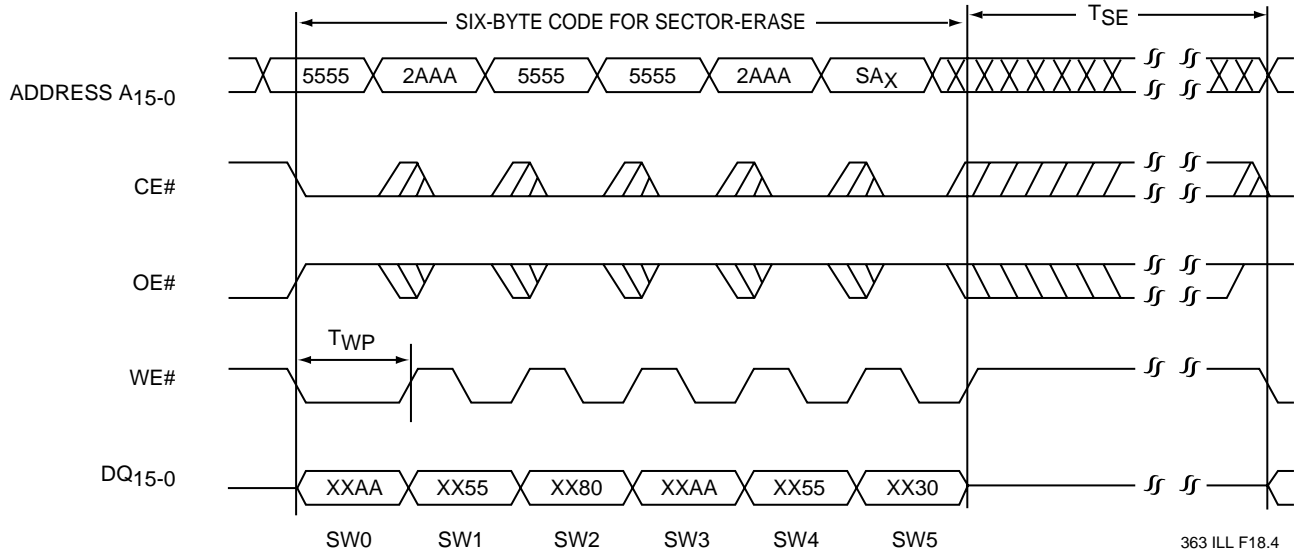

FIGURE 6: TOGGLE BIT TIMING DIAGRAM



Note: This device also supports CE# controlled Chip-Erase operation. The WE# and CE# signals are interchangeable as long as minimum timings are met. (See Table 10)
X can be V_{IL} or V_{IH}, but no other value.

FIGURE 7: WE# CONTROLLED CHIP-ERASE TIMING DIAGRAM



Note: This device also supports CE# controlled Sector-Erase operation. The WE# and CE# signals are interchangeable as long as minimum timings are met. (See Table 10)
SA_x = Sector Address
X can be V_{IL} or V_{IH}, but no other value.

FIGURE 8: WE# CONTROLLED SECTOR-ERASE TIMING DIAGRAM

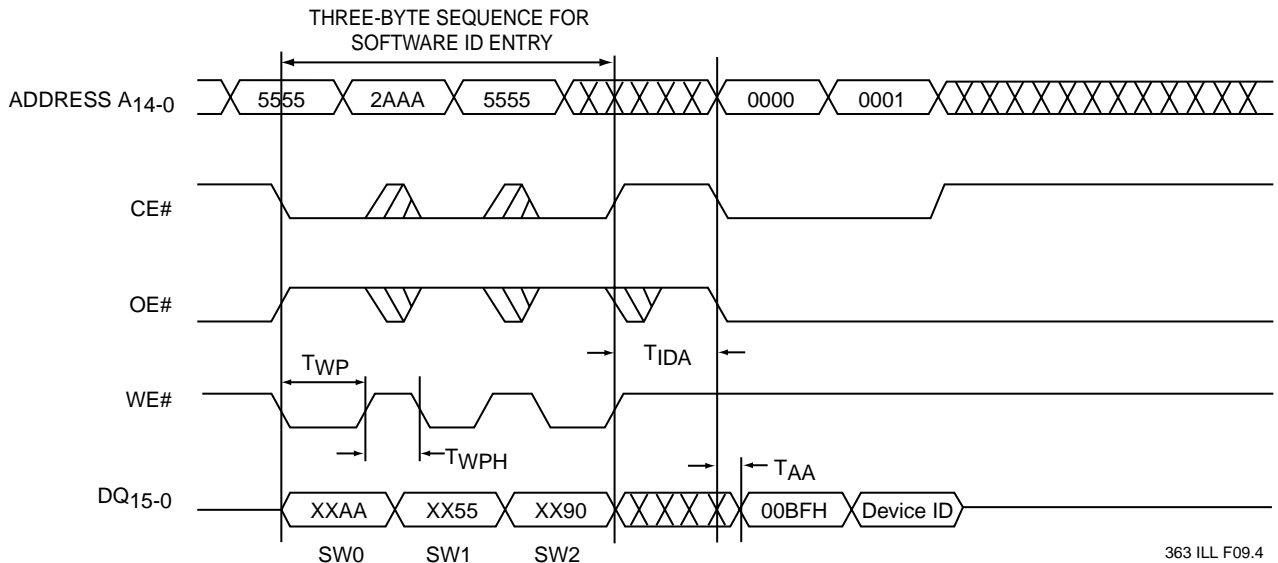

Note: X can be V_{IL} or V_{IH}, but no other value
Device ID = 2788H for SST39LF/VF100

FIGURE 9: SOFTWARE ID ENTRY AND READ



1 Mbit Multi-Purpose Flash SST39LF100 / SST39VF100

Data Sheet

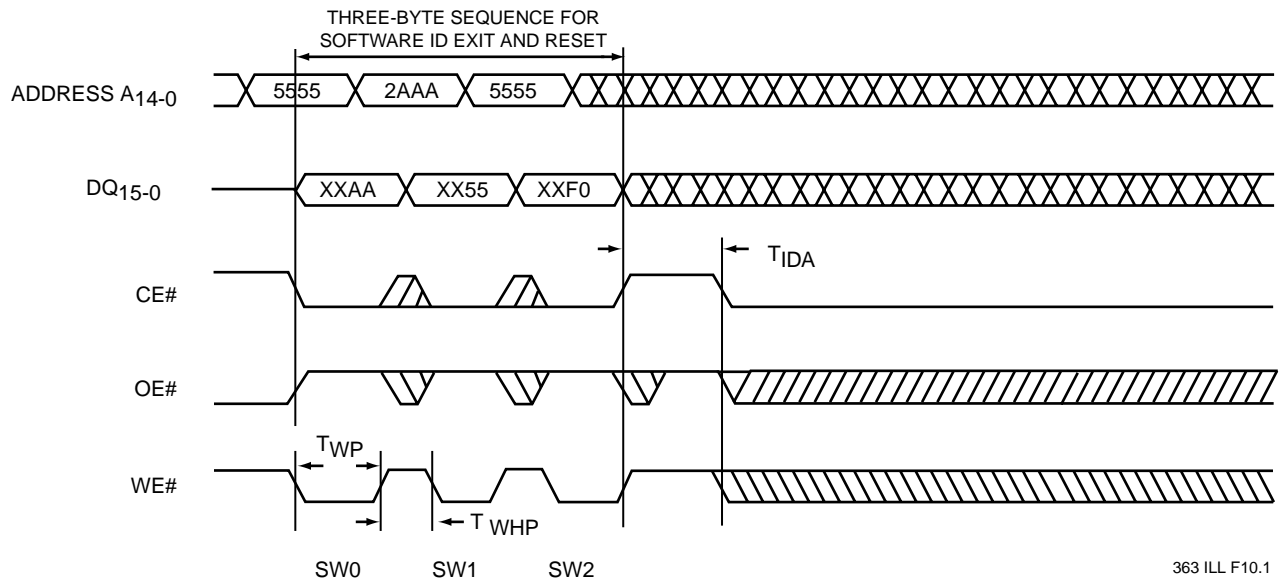

Note: X can be V_{IL} or V_{IH} , but no other value.

FIGURE 10: SOFTWARE ID EXIT

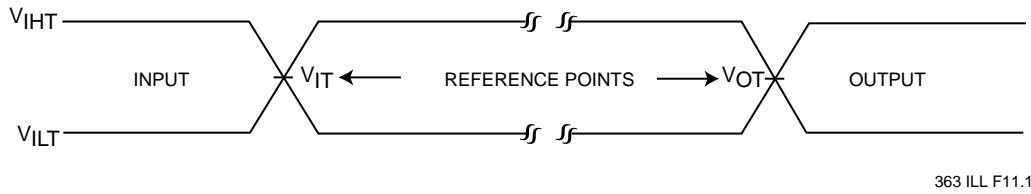

AC test inputs are driven at V_{IHT} ($0.9 V_{DD}$) for a logic "1" and V_{ILT} ($0.1 V_{DD}$) for a logic "0". Measurement reference points for inputs and outputs are V_{IT} ($0.5 V_{DD}$) and V_{OT} ($0.5 V_{DD}$). Input rise and fall times (10% \leftrightarrow 90%) are <5 ns.

Note: V_{IT} - V_{INPUT} Test
 V_{OT} - V_{OUTPUT} Test
 V_{IHT} - V_{INPUT} HIGH Test
 V_{ILT} - V_{INPUT} LOW Test

FIGURE 11: AC INPUT/OUTPUT REFERENCE WAVEFORMS

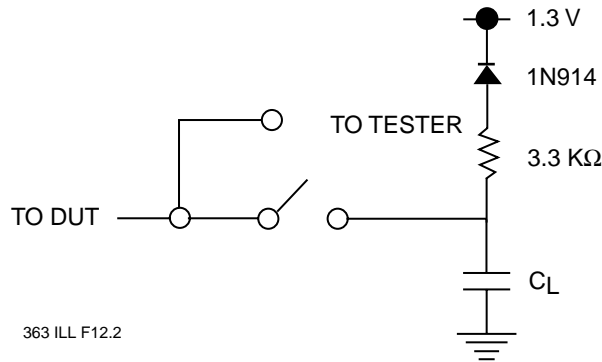

FIGURE 12: A TEST LOAD EXAMPLE

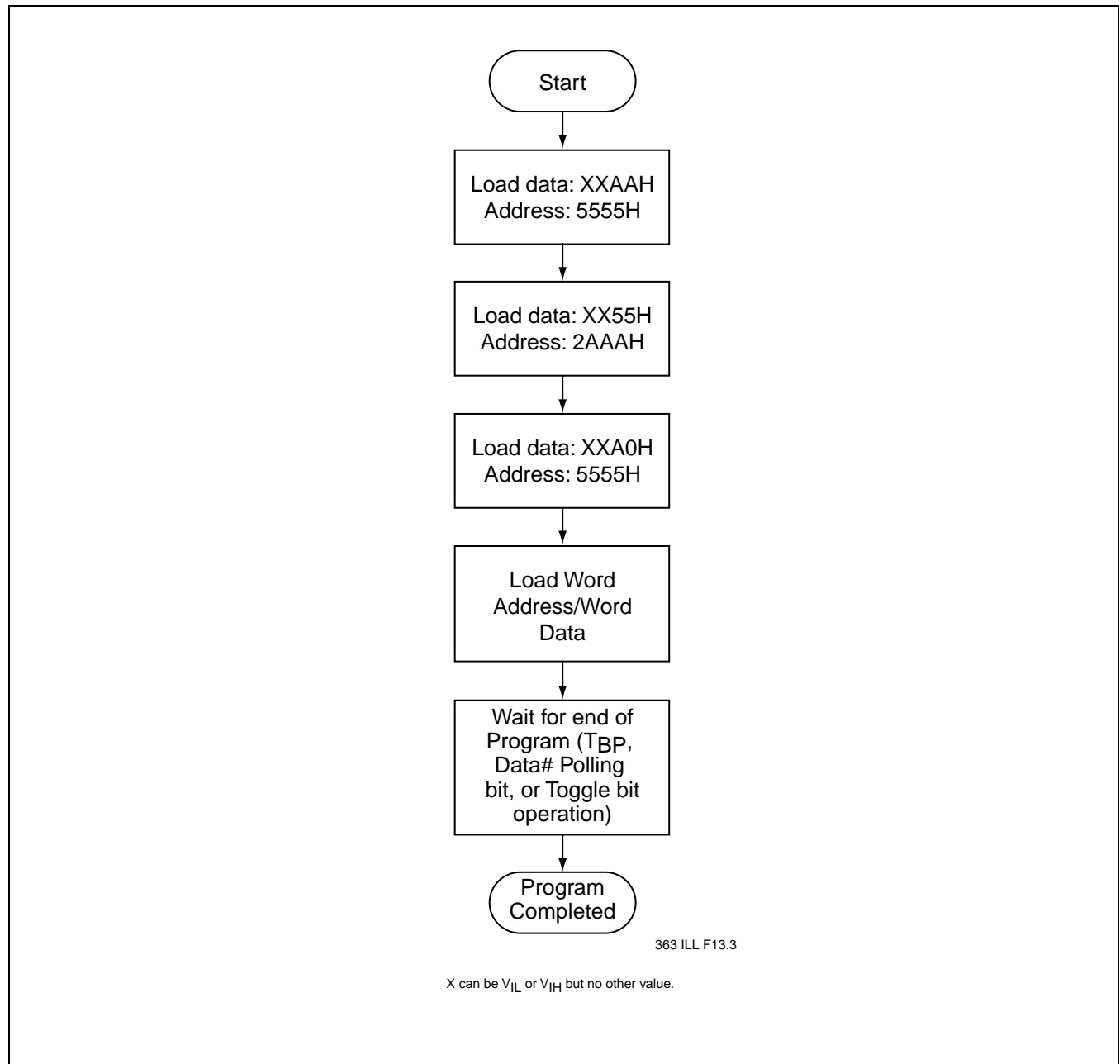

FIGURE 13: WORD-PROGRAM ALGORITHM

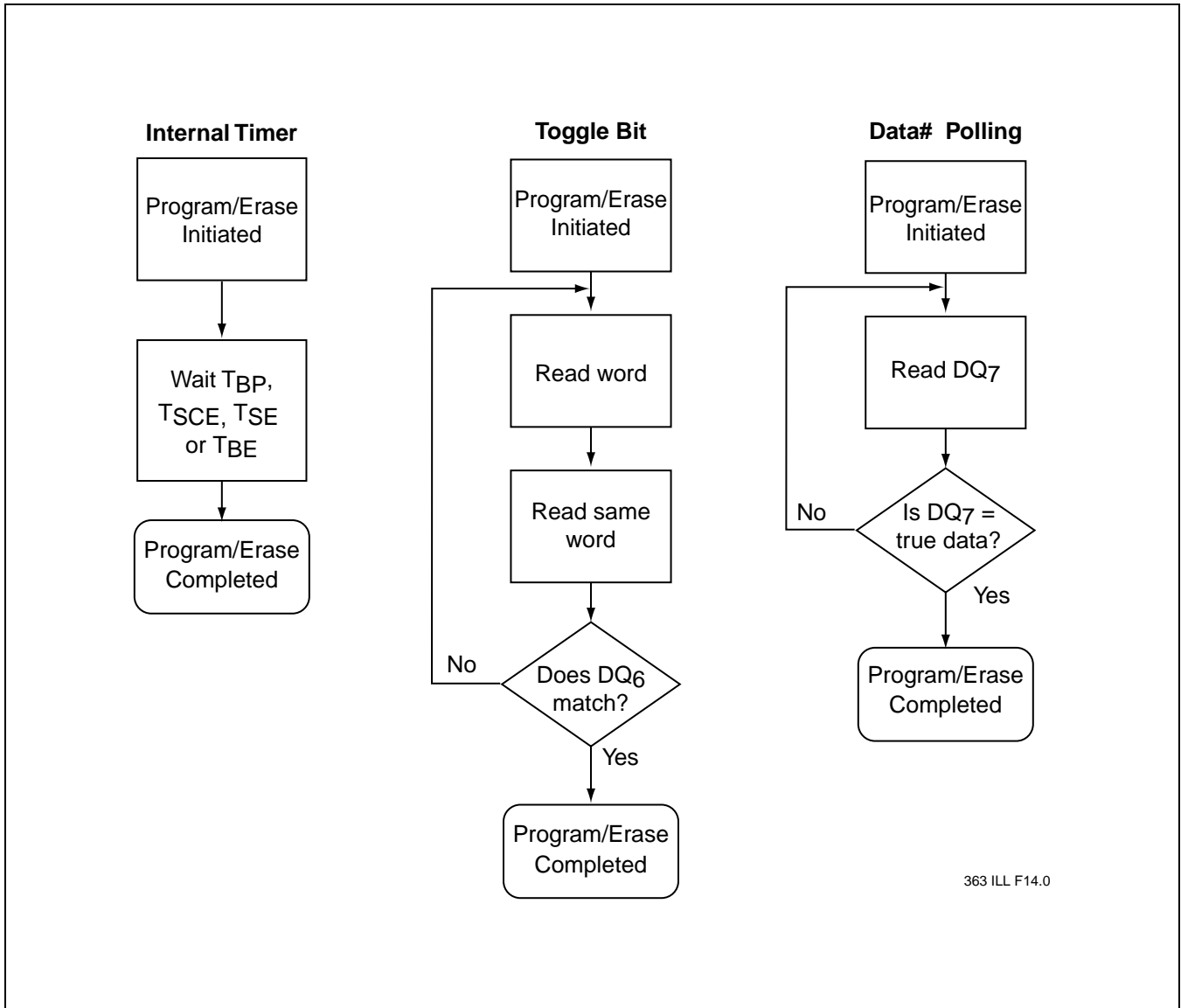

FIGURE 14: WAIT OPTIONS

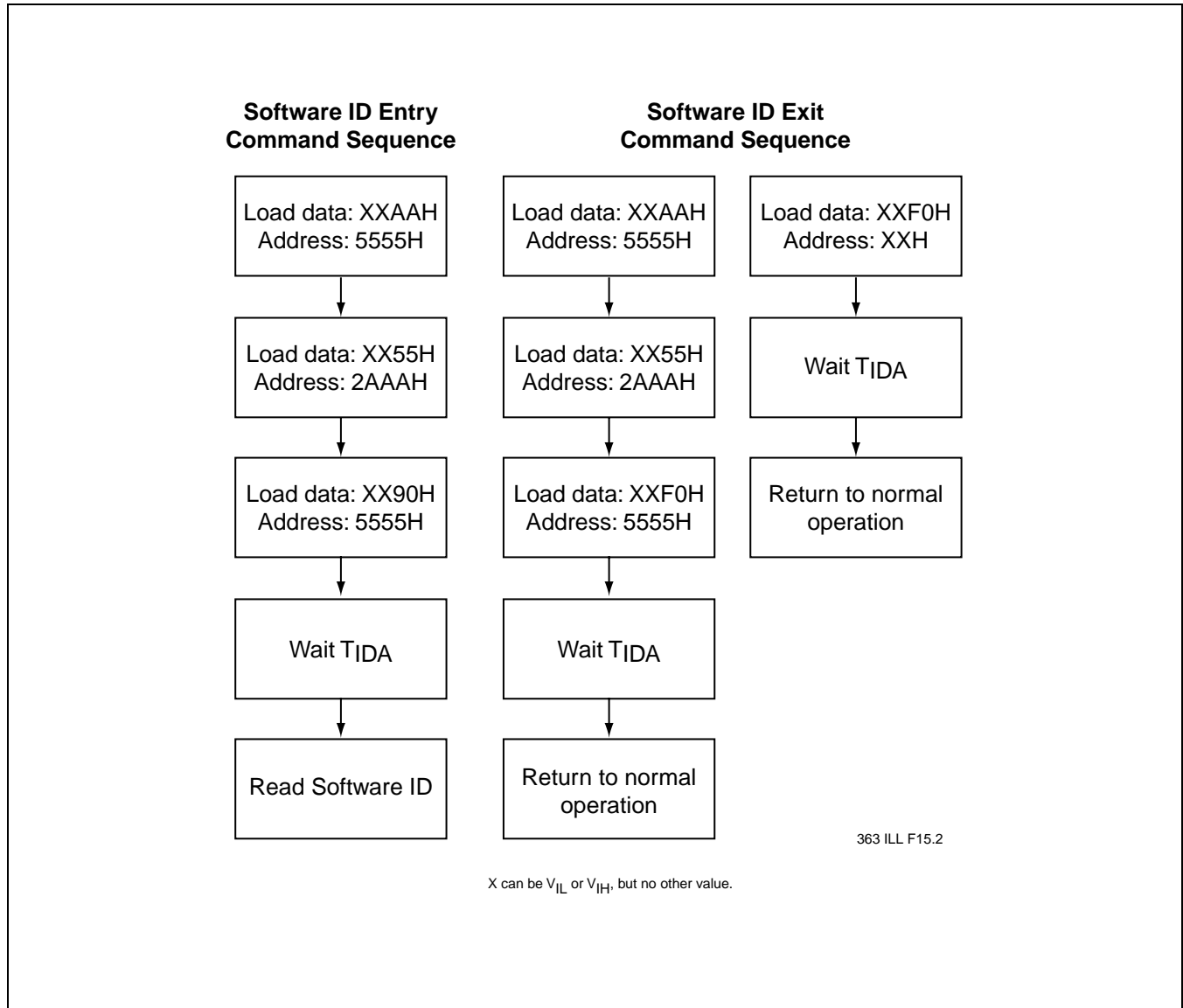

FIGURE 15: SOFTWARE PRODUCT ID COMMAND FLOWCHARTS

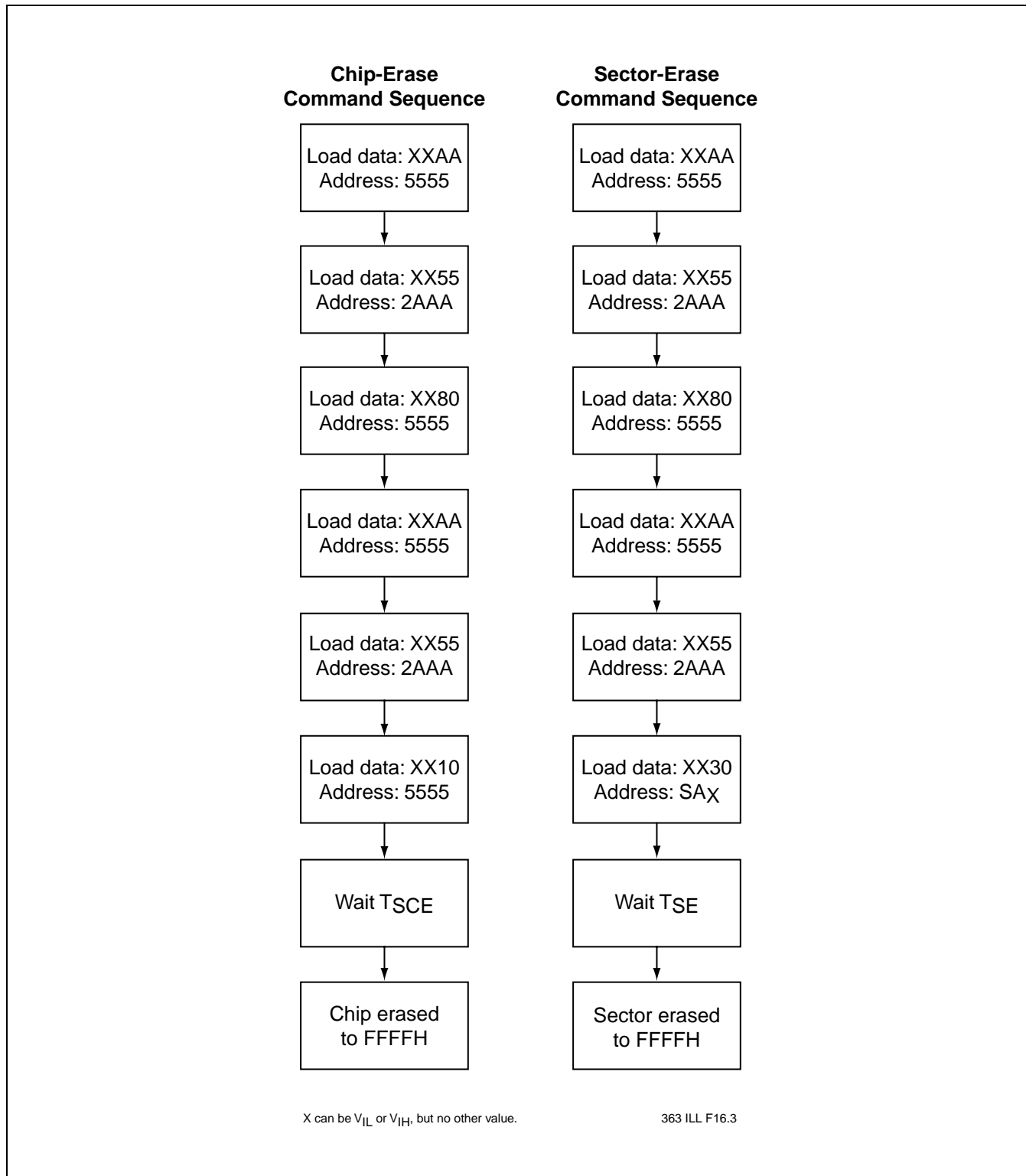

FIGURE 16: ERASE COMMAND SEQUENCE



1 Mbit Multi-Purpose Flash SST39LF100 / SST39VF100

Data Sheet

PRODUCT ORDERING INFORMATION

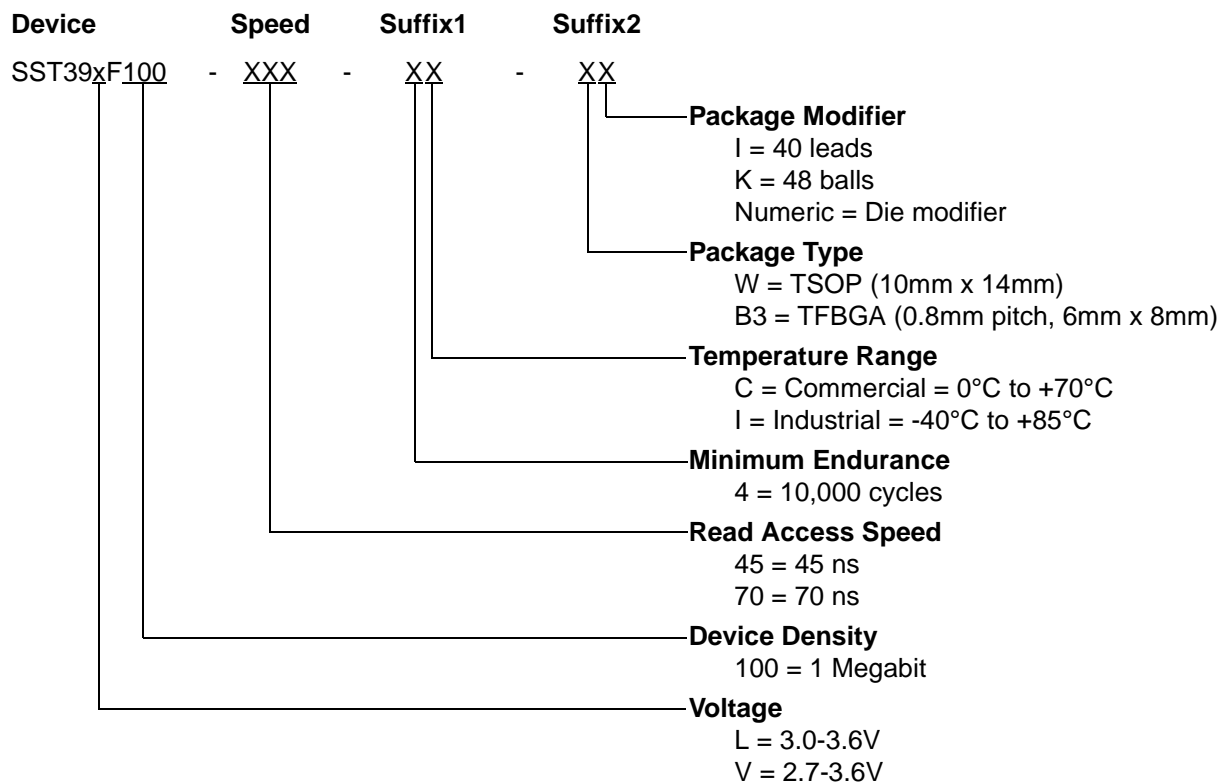

Valid combinations for SST39LF100

SST39LF100-45-4C-WI SST39LF100-45-4C-B3K

Valid combinations for SST39VF100

SST39VF100-70-4C-WI SST39VF100-70-4C-B3K
SST39VF100-70-4I-WI SST39VF100-70-4I-B3K

Note: Valid combinations are those products in mass production or will be in mass production. Consult your SST sales representative to confirm availability of valid combinations and to determine availability of new combinations.



PACKAGING DIAGRAMS

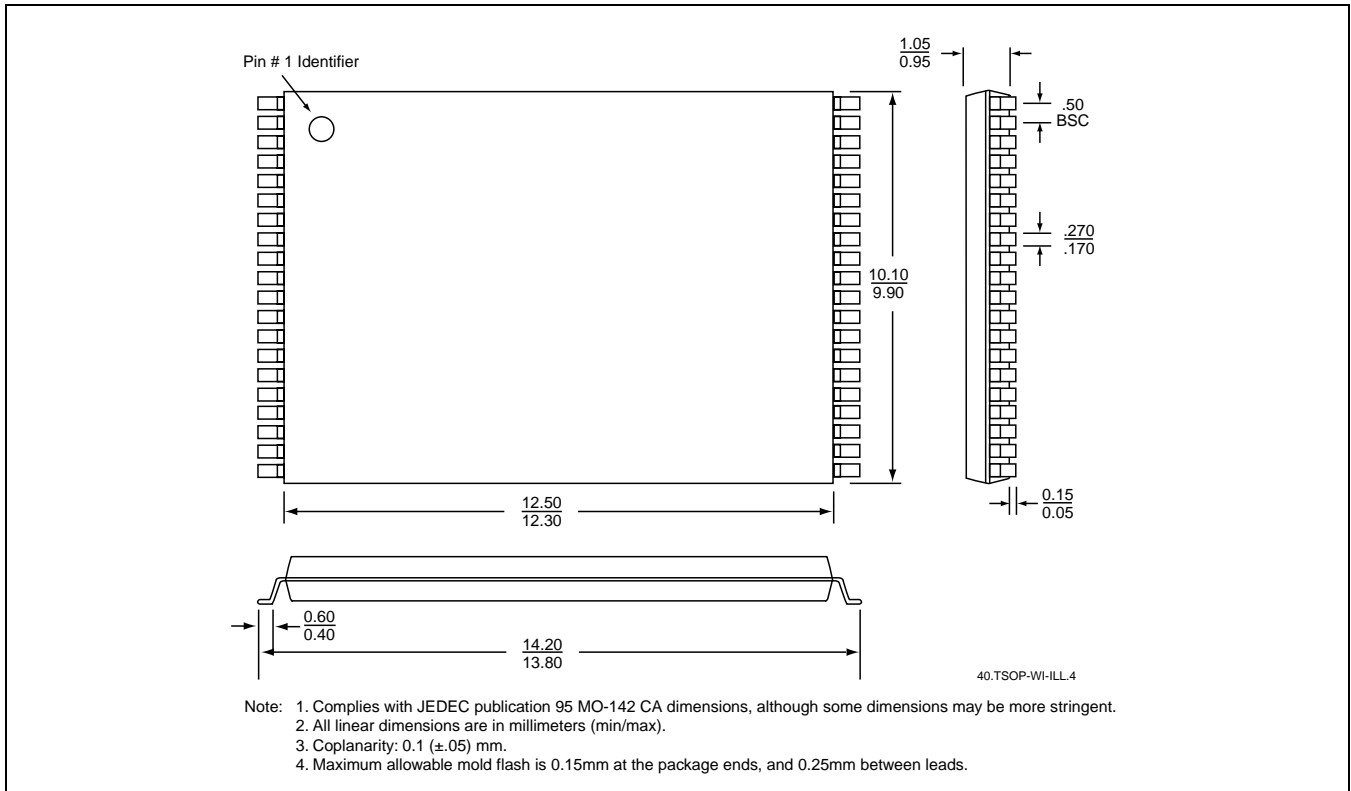

40-LEAD THIN SMALL OUTLINE PACKAGE (TSOP) 10MM X 14MM
SST PACKAGE CODE: WI



1 Mbit Multi-Purpose Flash SST39LF100 / SST39VF100

Data Sheet

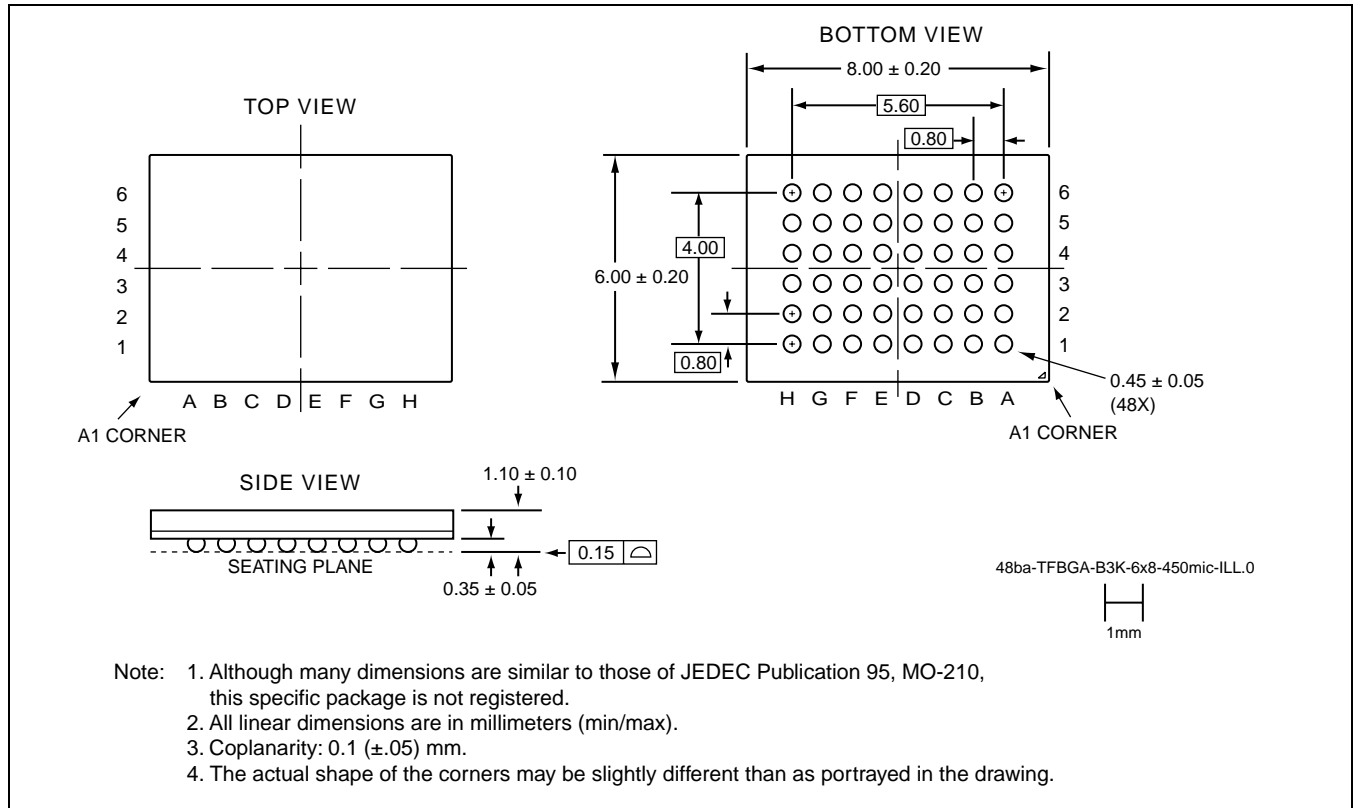

48-BALL THIN-PROFILE, FINE-PITCH BALL GRID ARRAY (TFBGA) 6MM X 8MM
SST PACKAGE CODE: B3K



1 Mbit Multi-Purpose Flash SST39LF100 / SST39VF100

Data Sheet

Silicon Storage Technology, Inc. • 1171 Sonora Court • Sunnyvale, CA 94086 • Telephone 408-735-9110 • Fax 408-735-9036
www.SuperFlash.com or www.ssti.com
