

## FEATURES

- Synchronizes loop-timed and system-timed T1 data streams
- Two-frame buffer depth; slips occur on frame boundaries
- Output indicates when slip occurs
- Buffer may be recentered externally
- Ideal for 1.544 to 2.048 MHz rate conversion
- Interfaces to parallel or serial backplanes
- Extracts and buffers robbed-bit signaling
- Inhibits signaling updates during alarm or slip conditions
- Integration feature “debounces” signaling
- Slip-compensated output indicates when signaling updates occur
- Compatible with DS2180A T1 Transceiver
- Surface mount package available, designated DS2176Q
- Industrial temperature range of -40°C to +85°C available, designated DS2176N

## PIN ASSIGNMENT

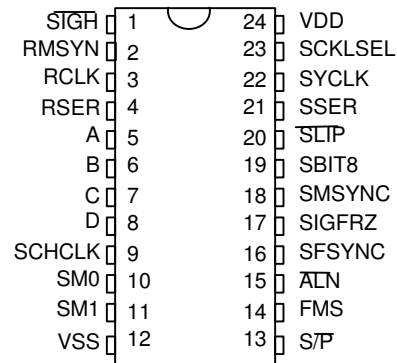

24-PIN 300 MIL DIP

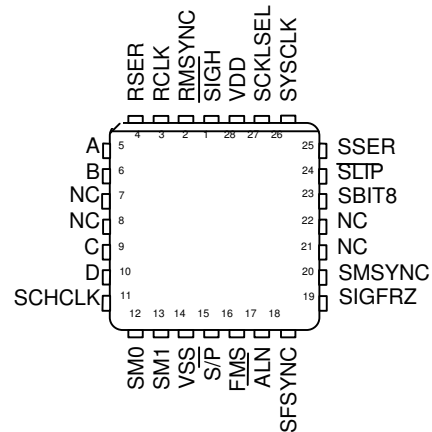

28-PIN PLCC

## DESCRIPTION

The DS2176 is a low-power CMOS device specifically designed for synchronizing receive side loop-timed T-carrier data streams with system side timing. The device has several flexible operating modes which simplify interfacing incoming data to parallel and serial TDM backplanes. The device extracts, buffers and integrates ABCD signaling; signaling updates are prohibited during alarm or slip conditions. The buffer replaces extensive hardware in existing applications with one “skinny” 24-lead package. Application areas include digital trunks, drop and insert equipment, transcoders, digital cross-connects (DACs), private network equipment and PABX-to-computer interfaces such as DMI and CPI.

## DS2176 BLOCK DIAGRAM Figure 1

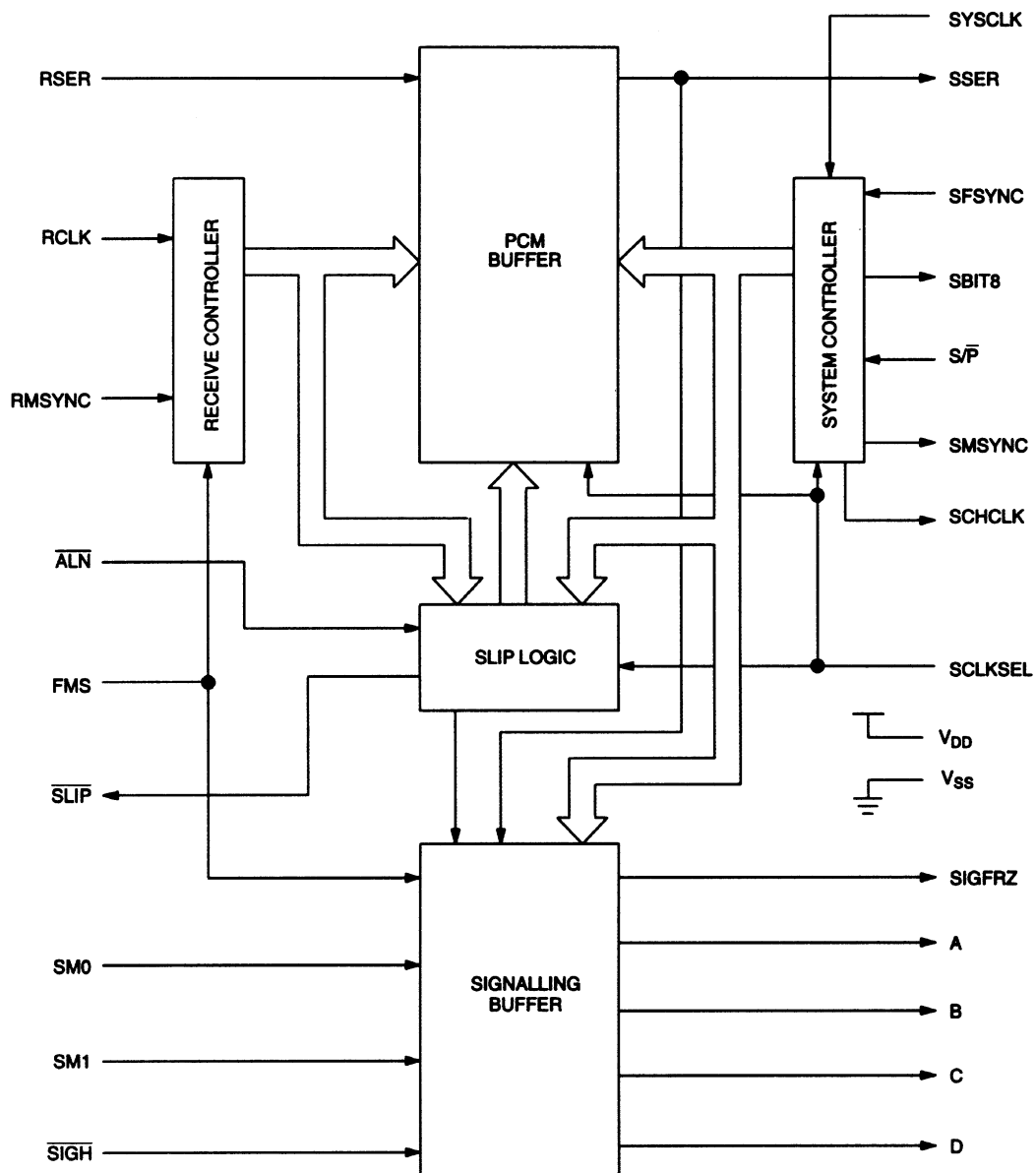

**PIN DESCRIPTION Table 1**

<b>PIN</b>	<b>SYMBOL</b>	<b>TYPE</b>	<b>DESCRIPTION</b>
1	$\overline{\text{SIGN}}$	I	<b>Signaling Inhibit.</b> When low, ABCD signaling updates are disabled for a period determined by SM0 and SM1, or until returned high.
2	RMSYNC	I	<b>Receive Multiframe Sync.</b> Must be pulsed high at multiframe boundaries to establish frame and multiframe alignment.
3	RCLK	I	<b>Receive Clock.</b> Primary 1.544 MHz clock.
4	RSER	I	<b>Receive Serial Data.</b> Sampled on Falling edge of RCLK.
5 6 7 8	A B C D	O	<b>Robbed-Bit Signaling Outputs.</b>
9	SCHCLK	O	<b>System Channel Clock.</b> Transitions high on channel boundaries; useful for serial to parallel conversion of channel data.
10 11	SM0 SM1	I	<b>Signaling Modes 0 and 1.</b> Select signaling supervision technique.
12	$V_{SS}$	–	<b>Signal Ground.</b> 0.0 volts.
13	S/P	I	<b>Serial/Parallel Select.</b> Tie to $V_{SS}$ for parallel backplane applications, to $V_{DD}$ for serial.
14	FMS	I	<b>Frame Mode Select.</b> Tie to $V_{SS}$ to select 193S(D4) framing to $V_{DD}$ for 193E (extended).
15	$\overline{\text{ALN}}$	I	<b>Align.</b> Recenters buffer on next system side frame boundary when forced low.
16	SFSYNC	I	<b>System Frame Sync.</b> Rising edge establishes start of frame.
17	SIGFRZ	O	<b>Signaling Freeze.</b> When high, indicates signaling updates have been disabled internally via a slip or externally by forcing $\overline{\text{SIGN}}$ low.
18	SMSYNC	O	<b>System Multiframe Sync.</b> Slip-compensated multiframe output; indicates when signaling updates are made.
19	SBIT8	O	<b>System Bit 8.</b> High during the LSB time of each channel. Used to reinsert extracted signaling into outgoing data stream.
20	$\overline{\text{SLIP}}$	O	<b>Frame Slip.</b> Active low, open collector output. Held low for 65 SYSCLK cycles when a slip occurs.
21	SSER	O	<b>System Serial Out.</b> Updated on rising edge of SYSCLK.
22	SYSCLK	I	System Clock. 1.544 or 2.048 MHz data clock.
23	SCLKSEL	I	<b>System Clock Select.</b> Tie to $V_{SS}$ for 1.544 MHz applications, to $V_{DD}$ for 2.048 MHz.
24	$V_{DD}$	–	<b>Positive Supply.</b> 5.0 volts.

## OVERVIEW

The DS2176 performs two primary functions: 1) synchronization of received T1 PCM data (looped timed) to host backplane frequencies; 2) supervision of robbed-bit signaling data embedded in the data stream. The buffer, while optimized for use with the DS2180A T1 Transceiver, is also compatible with other transceiver devices. The DS2180A data sheet should serve as a valuable reference when designing with the DS2176.

## RECEIVE SIDE TIMING FIGURE 2

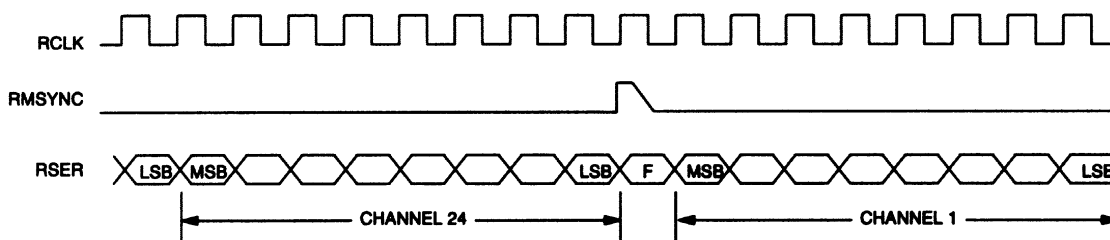

## DATA SYNCHRONIZATION

### PCM BUFFER

The DS2176 utilizes a 2-frame buffer (386 bits) to synchronize incoming PCM data to the system backplane clock. The buffer samples data at RSER on the falling edge of RCLK. Output data appears at SSER and is up-dated on the rising edge of SYSCLK. A rising edge at RMSYNC establishes receive side frame and multi-frame alignment. A rising edge at SFSYNC establishes system side frame alignment. The buffer depth is constantly monitored by onboard contention logic; a “slip” occurs when the buffer is completely emptied or filled. Slips automatically recenter the buffer to a one-frame depth and always occur on frame boundaries.

### SLIP CORRECTION CAPABILITY

The 2-frame buffer depth is adequate for most T-carrier applications where short-term jitter synchronization, rather than correction of significant frequency differences, is required. The DS2176 provides an ideal balance between total delay and slip correction capability.

### BUFFER RECENTERING

Many applications require that the buffer be recentered during system power-up and/or initialization. Forcing  $\overline{ALN}$  low recenters the buffer on the occurrence of the next frame sync boundary. A slip will occur during this recentering if the buffer depth is adjusted. If the depth is presently optimum, no adjustment (slip) occurs.  $\overline{SLIP}$  is held low for 65 SYSCLK cycles when a slip occurs.  $\overline{SLIP}$  is an active-low, open collector output.

### BUFFER DEPTH MONITORING

SMSYNC is a system side output pulse which indicates system side multiframe boundaries. The distance between rising edges at RMSYNC and SMSYNC indicates the current buffer depth. Slip direction and/or an impending slip condition may be determined by monitoring RMSYNC and SMSYNC real time. SMSYNC is held high for 65 SYSCLK cycles.

### CLOCK SELECT

The device is compatible with two common backplane frequencies: 1.544 MHz, selected when SCLKSEL=0; and 2.048 MHz, selected when SCLKSEL=1. In 1.544 MHz applications the F-bit is

passed through the receive buffer and presented at SSER immediately after the rising edge of the system side frame sync. The F-bit is dropped in 2.048 MHz applications and the MSB of channel 1 appears at SSER one bit period after a rising edge at SFSYNC. SSER is forced to 1 in all channels greater than 24. See Figures 3 and 4.

In 2.048 MHz applications (SCLKSEL=1), the PCM buffer control logic establishes slip criteria different from that used in 1.544 MHz applications to compensate for the faster system-side read frequency.

## PARALLEL COMPATIBILITY

The DS2176 is compatible with parallel and serial back-planes. Channel 1 data appears at SSER after a rising edge at SFSYNC as shown in Figures 3 and 4 (serial applications,  $S/\bar{P}=1$ ). The device utilizes a look-ahead circuit in parallel applications ( $S/\bar{P}=0$ ). Data is output 8 clocks earlier, allowing the user to convert parallel data eternally.

## SYSTEM MULTIFRAME BOUNDARY TIMING (SYSCLK = 1.544 MHz) Figure 3

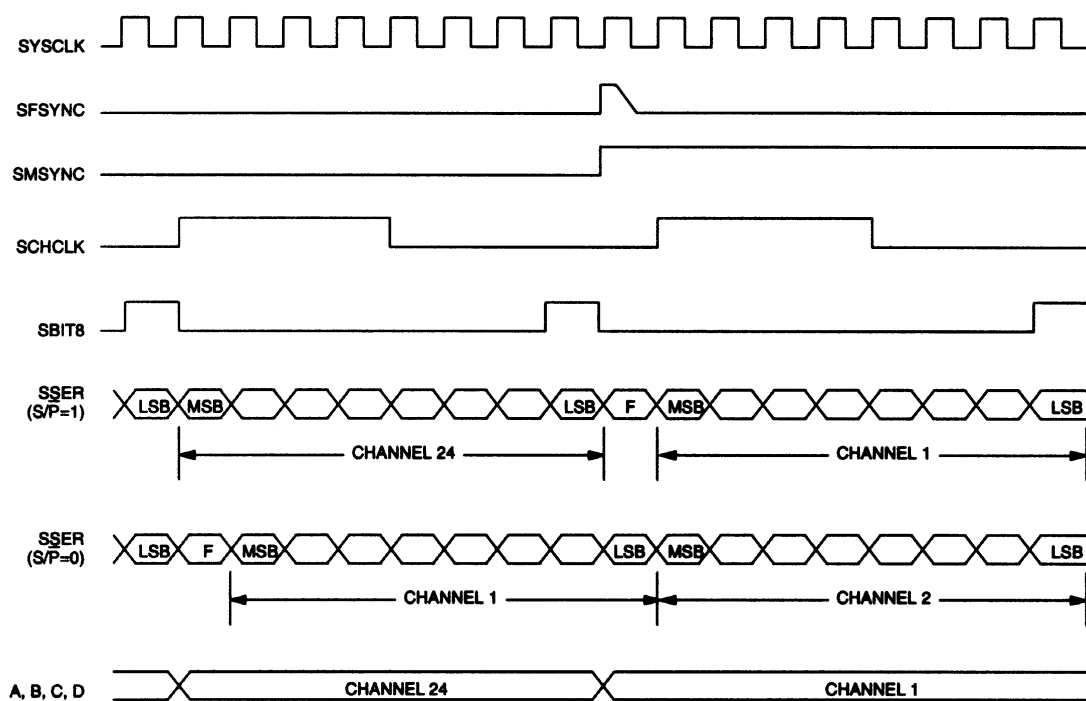

### SYSTEM MULTIFRAME BOUNDARY TIMING (SYSCLK = 2.048 MHz) Figure 4

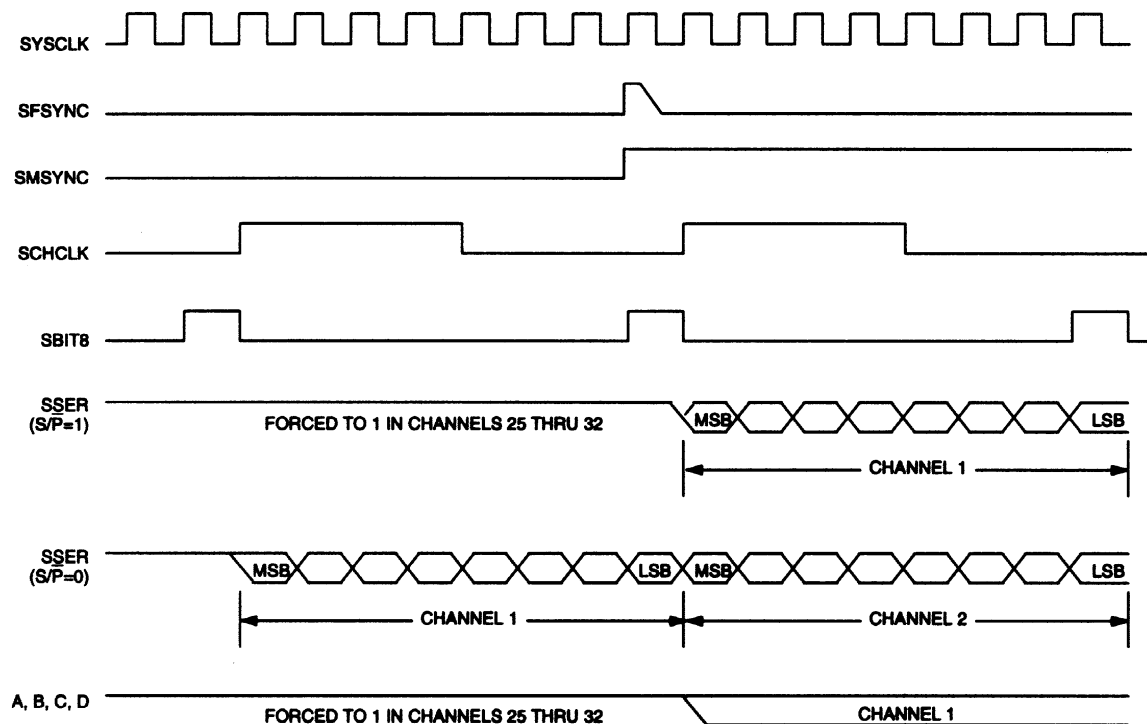

### 193S SYSTEM MULTIFRAME TIMING Figure 5

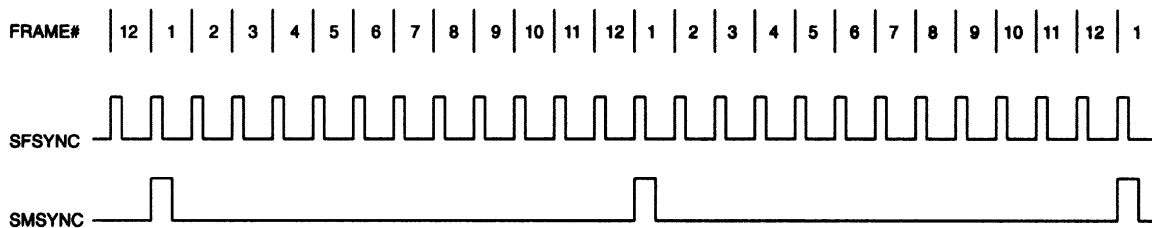

### 193E SYSTEM MULTIFRAME TIMING Figure 6

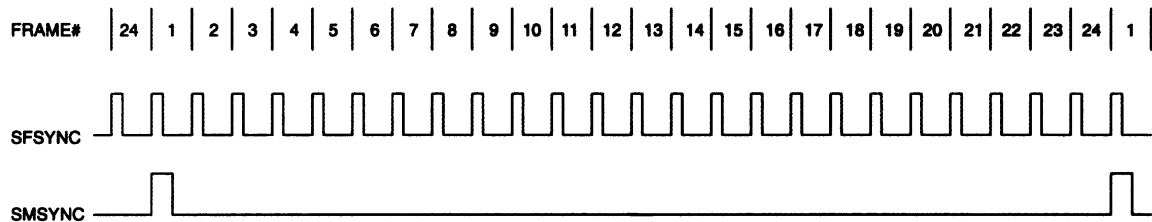

## SIGNALING SUPERVISION

### EXTRACTION

In digital channel banks, robbed-bit signaling data is inserted into the LSB position of each channel during signaling frames. In 193S framing (FMS=0) applications, A signaling data is inserted into frame 6 and B signaling data is inserted into frame 12. 193E framing (FMS=1) includes two additional signaling bits: C signaling is inserted into frame 18 and D signaling is inserted into frame 24. This embedded signaling data is synchronized to system side timing (via the PCM buffer) before being extracted and presented at outputs A, B, C, and D. Outputs A, B, C, and D are valid for each individual channel time and are repeated per channel for all frames of the multiframe. In 193S applications, outputs C and D contain the previous multiframe's A and B data. Signaling updates occur once per multiframe at the rising edge of SMSYNC unless prohibited by a freeze.

### FREEZE

The signaling buffer allows the DS2176 to “freeze” (pre-vent update of) signaling information during alarm or slip conditions. A slip condition or forcing  $\overline{\text{SIGH}}$  low freezes signaling; duration of the freeze is dependent on SM0 and SM1. Updates will be unconditionally prohibited when  $\overline{\text{SIGH}}$  is held low. During freezing conditions “old” data is recirculated in the output registers and appears at A, B, C and D. SIGFRZ is held high during the freeze condition, and returns low on the next signaling update. Input to output delay of signaling data is equal to 1 multiframe (the depth of the signaling buffer) the current depth of the PCM buffer (1 frame  $\pm$  approximately 1 frame).

### INTEGRATION

Signaling integration is another feature of the DS2176; when selected, it minimizes the impact of random noise hits on the span and resultant robbed-bit signaling corruption. Integration requires that per-channel signaling data be in the same state for two or more multiframes before appearing at A, B, C and D. SM0 and SM1 are used to select the degree of integration or to totally by-pass the feature. Integration is limited to two multi-frames during slip or alarm conditions to minimize up-date delay.

### CLEAR CHANNEL CONSIDERATIONS

The DS2176 does not merge the “processed” signaling information with outgoing PCM data at SSER; this assures integrity of data in clear channel applications. SBIT8 indicates the LSB position of each channel; when combined with off-chip support logic, it allows the user to selectively re-insert robbed-bit signaling data into the outgoing data stream.

**SIGNALING SUPERVISION MODES Table 2**

SM0	SM1	FMS	SELECTED MODE
0	0	0	193S framing, no integration, 1 multiframe freeze.
0	0	1	193E framing, no integration, 1 multiframe freeze.
0	1	0	193S framing, 2 multiframes integration and freeze.
0	1	1	193E framing, 2 multiframes integration and freeze.
1	0	0 <sup>1</sup>	193S framing, 5 multiframes integration, 2 multiframes freeze.
1	0	1 <sup>1</sup>	193E framing, 3 multiframes integration, 2 multiframes freeze.
1	1	0	193S framing, no integration, 1 multiframe freeze, replace robbed bit signaling bits at SSER with ones.
1	1	1	193E framing, no integration, 1 multiframe freeze, replace robbed bit signaling bits at SSER with ones.

**NOTE:**

1. During slip or alarm conditions, integration is limited to two multiframes to minimize signaling delay.

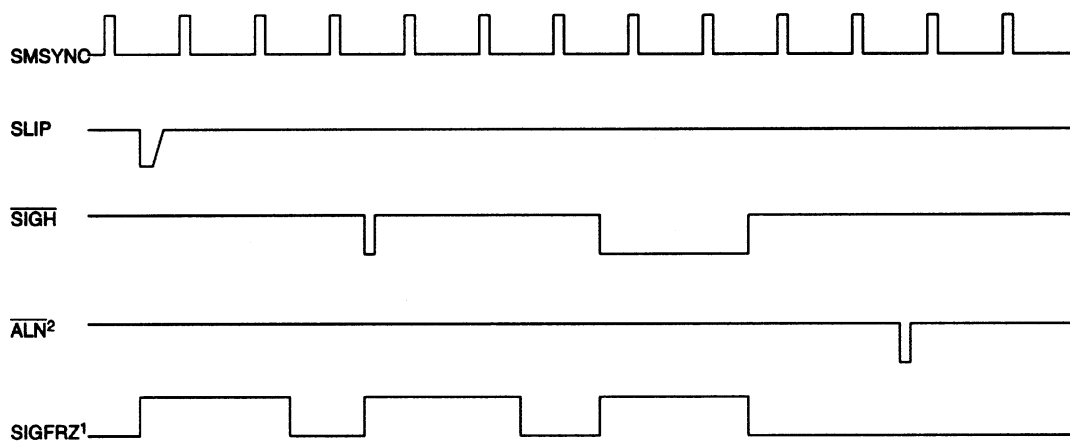
**SLIP AND SIGNALING SUPERVISION LOGIC TIMING Figure 7****NOTES:**

1. Integration feature disabled (SM0=SM1=0) in timing set shown.
2. Depending on present buffer depth, forcing  $\overline{ALN}$  low may or may not cause a slip condition.



# DS2176/DS2180A SYSTEM APPLICATION

Figure 8 shows how the DS2180A T1 Transceiver and DS2176 Receive Buffer interconnect in a typical application.

## SERIAL 1.544 MHz BACKPLANE INTERFACE Figure 8

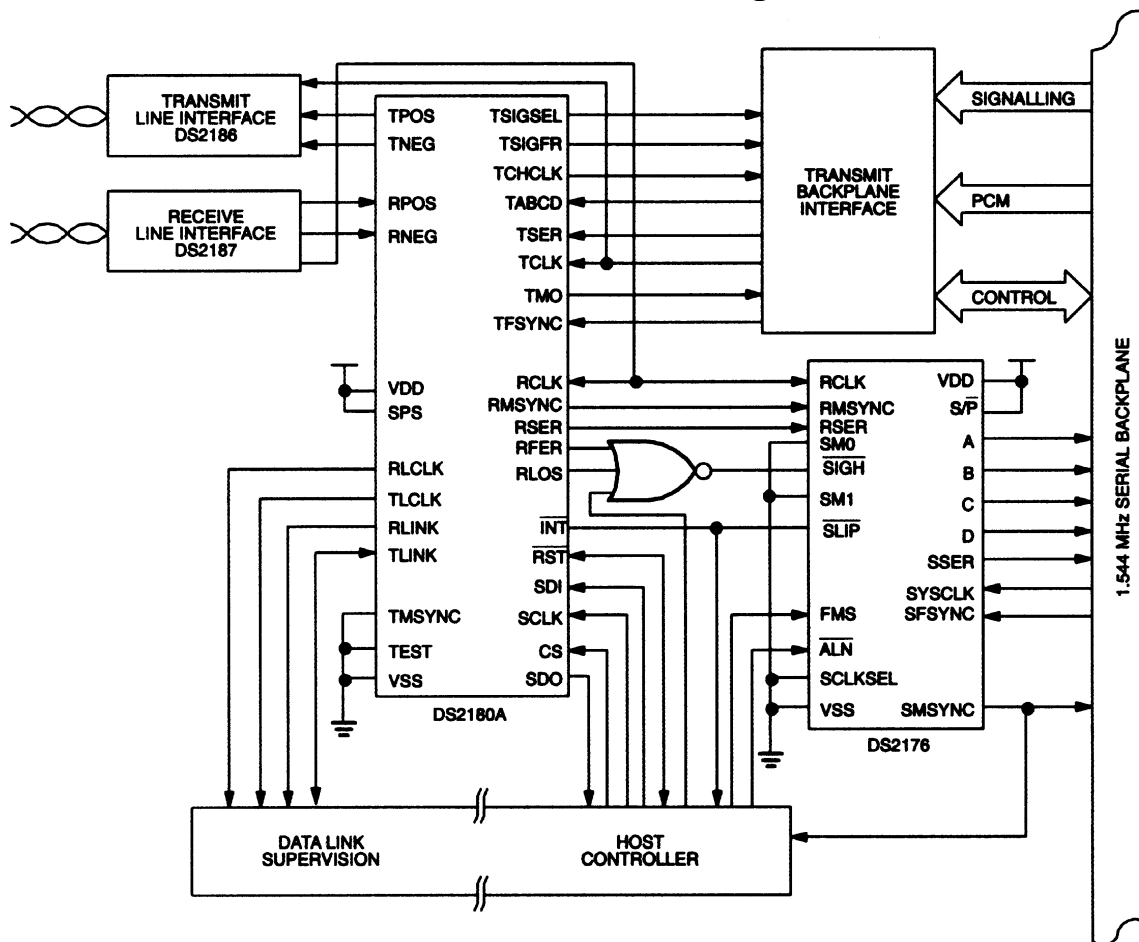

**ABSOLUTE MAXIMUM RATINGS\***

Voltage on Any Pin Relative to Ground	-1.0V to +7.0V
Operating Temperature	0°C to 70°C
Storage Temperature	-55°C to +125°C
Soldering Temperature	260°C for 10 seconds

\*This is a stress rating only and functional operation of the device at these or any other conditions above those indicated in the operation sections of this specification is not implied. Exposure to absolute maximum rating conditions for extended periods of time may affect reliability.

**RECOMMENDED DC OPERATING CONDITIONS (0°C to 70°C)**

PARAMETERS	SYMBOL	MIN	TYP	MAX	UNITS	NOTES
Logic 1	$V_{IH}$	2.0		$V_{DD}+0.3$	V	
Logic 0	$V_{IL}$	-0.3		+0.8	V	
Supply	$V_{DD}$	4.5		5.5	V	

**DC ELECTRICAL CHARACTERISTICS (0°C to 70°C;  $V_{DD} = 5V \pm 10\%$ )**

PARAMETERS	SYMBOL	MIN	TYP	MAX	UNITS	NOTES
Supply Current	$I_{DD}$		5	10	mA	1,2
Input Leakage	$I_{IL}$	-1.0		+1.0	$\mu A$	
Output Current @ 2.4V	$I_{OH}$	-1.0			mA	3
Output Current @ 0.4V	$I_{OL}$	+4.0			mA	4
Output Leakage	$I_{LO}$	-1.0		+1.0	$\mu A$	5

**NOTES:**

1.  $TCLK=RCLK=1.544$  MHz.
2. Outputs open.
3. All outputs except  $\overline{SLIP}$ , which is open collector.
4. All outputs.
5. Applies to  $\overline{SLIP}$  when tri-stated.

**CAPACITANCE ( $t_A=25^\circ C$ )**

PARAMETERS	SYMBOL	MIN	TYP	MAX	UNITS	NOTES
Input Capacitance	$C_{IN}$			5	pF	
Output Capacitance	$C_{out}$			7	pF	

**AC ELECTRICAL CHARACTERISTICS****(0°C to 70°C; V<sub>DD</sub> = 5V ± 10%)**

PARAMETERS	SYMBOL	MIN	TYP	MAX	UNITS	NOTES
RCLK Period	<sup>t</sup> RCLK	250	648		ns	
RCLK, SYSCLK Rise and Fall Times	<sup>t</sup> R, <sup>t</sup> F			20	ns	
RCLK Pulse Width	<sup>t</sup> RWH, <sup>t</sup> RWL	125	324		ns	
SYSCLK Pulse Width	<sup>t</sup> SWH, <sup>t</sup> SWL	100	244		ns	
SYSCLK Period	<sup>t</sup> SYSCLK	200	488		ns	
RMSYNC Setup to RCLK Falling	<sup>t</sup> SC	20		<sup>t</sup> RWH <sup>-5</sup>	ns	
SFSYNC Setup to SYSCLK Falling	<sup>t</sup> SC	20		<sup>t</sup> SWH <sup>-5</sup>	ns	
RMSYNC, SFSYNC, <u>SIGH</u> , <u>ALN</u> Pulse Width	<sup>t</sup> PW	50		ns	ns	
RSER Setup to RCLK Falling	<sup>t</sup> SD	50			ns	
RSER Hold from RCLK Falling	<sup>t</sup> HD	50			ns	
Propagation Delay SYSCLK to SSER, A,B,C,D	<sup>t</sup> PVD			100	ns	
Propagation Delay SYSCLK to SMSYNC High	<sup>t</sup> PSS			75	ns	
Propagation Delay SYSCLK or RCLK to <u>SLIP</u> Low	<sup>t</sup> PS			100	ns	
Propagation Delay SYSCLK to SIGFRZ Low/High	<sup>t</sup> PSF			75	ns	
<u>ALN</u> , <u>SIGH</u> Setup to SFSYNC Rising	<sup>t</sup> SR	500			ns	

**NOTES:**

1. Measured at V<sub>IH</sub>=2.0V, V<sub>IL</sub>=0.8V, and 10 ns maximum rise and fall times.
2. Output load capacitance = 100 pF.

## RECEIVE AC DIAGRAM Figure 9

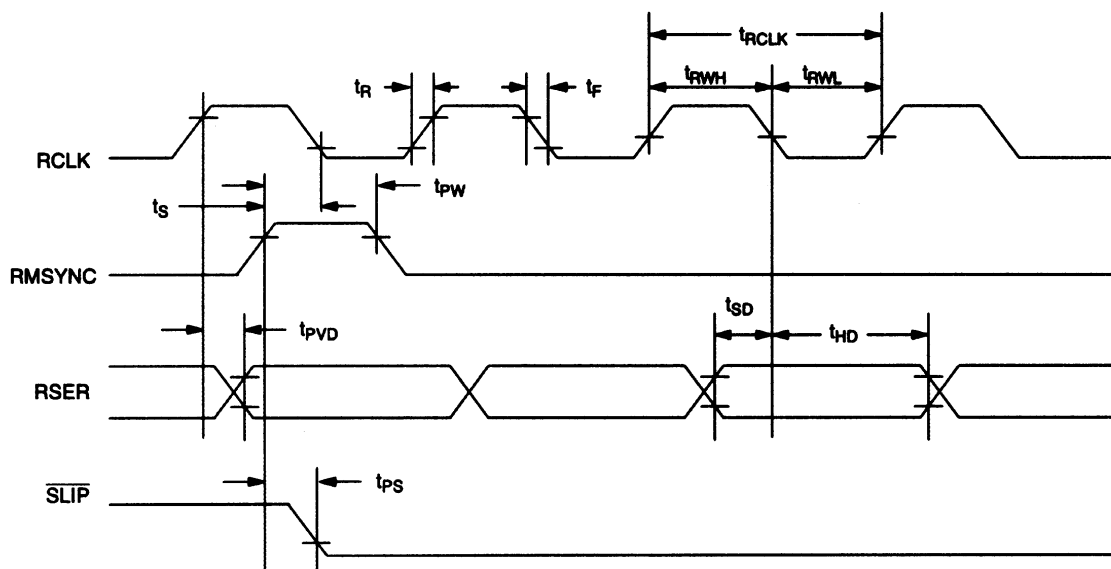

## SYSTEM AC TIMING DIAGRAM Figure 10

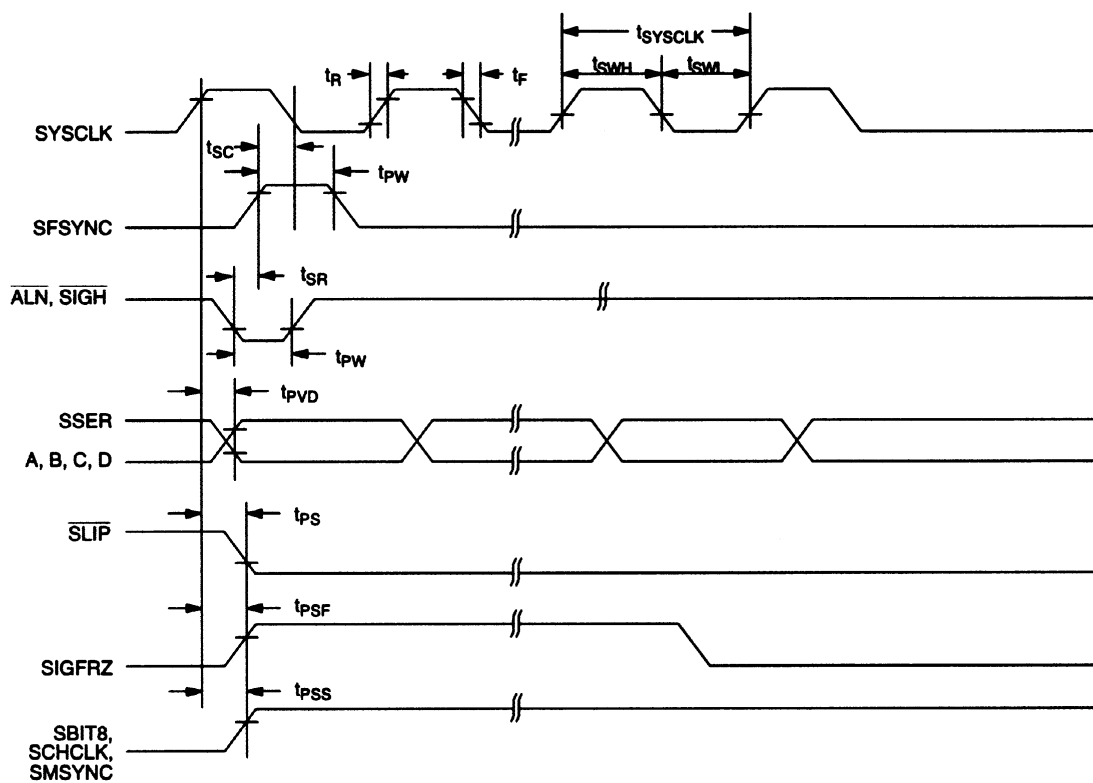

## DS2176 T1 RECEIVE BUFFER

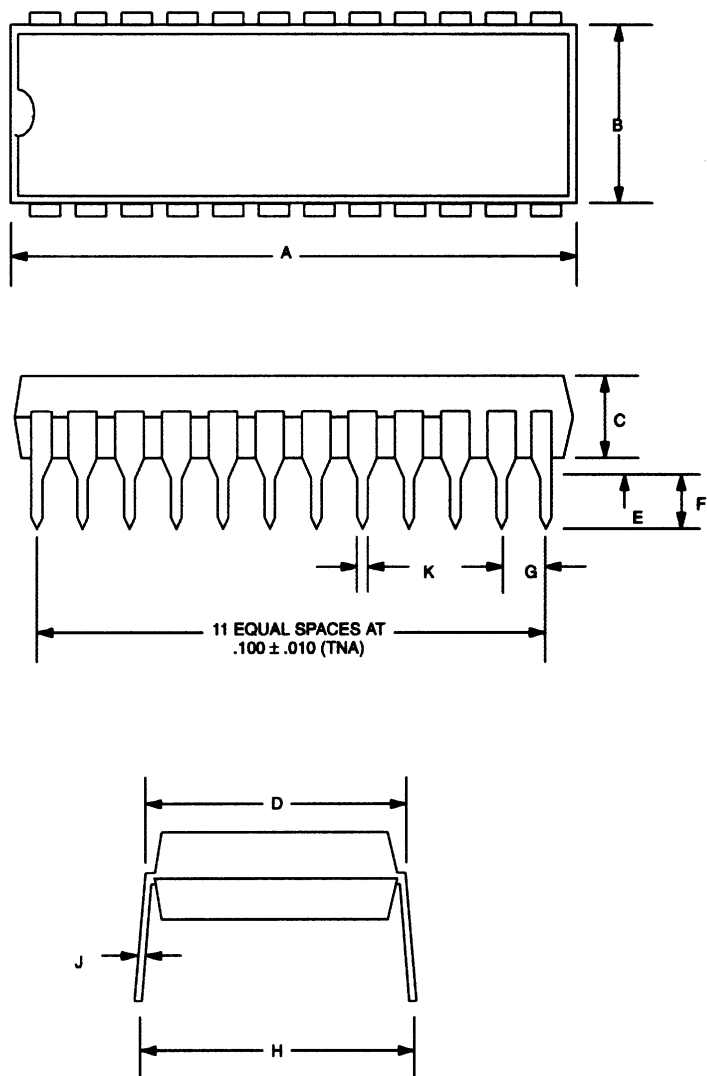

PKG	24-PIN	
	MIN	MAX
A IN. MM	1.245	1.265
B IN. MM	0.250	0.270
C IN. MM	0.125	0.145
D IN. MM	0.300	0.325
E IN. MM	0.015	0.040
F IN. MM	0.125	0.135
G IN. MM	0.090	0.110
H IN. MM	0.325	0.420
J IN. MM	0.008	0.012
K IN. MM	0.015	0.022

## DS2176Q

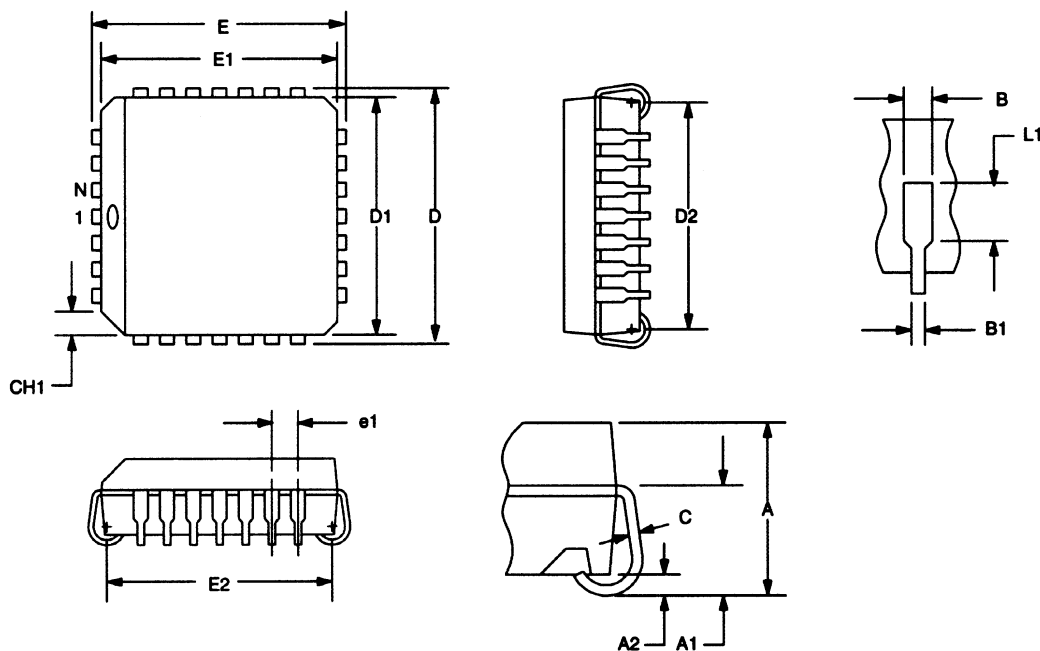

DIM	INCHES	
	MIN	MAX
A	0.165	0.180
A1	0.090	0.120
A2	0.020	-
B	0.026	0.033
B1	0.013	0.021
C	0.009	0.012
D	0.485	0.495
D1	0.450	0.456
D2	0.390	0.430
E	0.485	0.495
E1	0.450	0.456
E2	0.390	0.430
L1	0.060	-
N	28	-
e1	0.050 BSC	
CH1	0.042	0.048

---

## DATA SHEET REVISION SUMMARY

The following represent the key differences between 04/19/95 and 06/13/97 version of the DS2176 data sheet. Please review this summary carefully.

1. SYNC/CLOCK Relationship in timing diagram