

**Description**

The new electronic overcurrent protection REX12 consists of the supply module EM12-T and the single or double channel electronic circuit protector REX12-T which allows modular side-by-side mounting. The modules with a width of only 12.5 mm feature push-in technology including press release buttons and allow time-saving and maintenance-free wiring without tools. The supply module is designed for DC 24 V and 40 A and accommodates max. 10 mm<sup>2</sup> with wire end ferrule as a plus (+) supply. On the load output side the circuit protector can be wired with 2.5 mm<sup>2</sup>.

The new generation of electronic overcurrent protection REX12 combines flexibility with a compact design. It is exactly tailored to the needs of machine and panel builders. And what is more: no additional accessories are required when connecting the individual components electrically and mechanically. This helps save time and money!



**Features**

- Combination of supply module and electronic circuit protector
- Single and double channel selective load protection by means of electronic trip curve
- No accessories required for connecting the components
- Width per channel only 12.5 mm (1-channel) or 6.25 mm (2-channel)
- Fixed current ratings from 1 A to 10 A
- Integral fail-safe element, adjusted to current rating
- Switching capacitive loads up to 20,000 µF
- Manual ON/OFF/reset momentary switch
- Clear status indication by means of LED and signal contact Si
- Connection via push-in terminals including orange press release buttons

**Benefits**

- Saves cost – no further accessories required
- Saves time through innovative and flexible mounting and connection technology
- Saves space – with a width of only 12.5 mm for two channels
- Provides flexibility through ease of mounting, disassembly and modular design

**Approvals and standards**

Approval authority	Standard	Rated voltage	Current rating range
UL	UL 2367	DC 24 V	1 A... 10 A
UL	UL60947 / cULus508listed under preparation	DC 24 V	1 A... 10 A

**Overview of ordering number codes**

Supply module	EM12-T01-001-DC24V-40A
circuit protectors: 1-channel	REX12-TA1-107-DC24V-1A REX12-TA1-107-DC24V-2A REX12-TA1-107-DC24V-3A REX12-TA1-107-DC24V-4A REX12-TA1-107-DC24V-6A REX12-TA1-107-DC24V-8A REX12-TA1-107-DC24V-10A
circuit protectors: 2-channel	REX12-TA2-107-DC24V-2A/2A REX12-TA2-107-DC24V-4A/4A REX12-TA2-107-DC24V-6A/6A

**Technical data (T<sub>amb</sub> = +23 °C, U<sub>B</sub> = DC 24 V)**

REX12-TAx-xxx circuit protectors		
REX12-TA1-107-DC24V-xA	1-channel	
REX12-TA2-107-DC24V-xA/xA	2-channel	
Operating voltage U <sub>B</sub>	DC 24 V (18...30 V)	
Closed-circuit current I <sub>0</sub>		
REX12-TA1 1-channel	in ON condition	typically 5 mA
REX12-TA2 2-channel	in ON condition	typically 8 mA
Reverse polarity protection	yes	
Power failure buffering time	up to 10 ms	
Current ratings I <sub>N</sub>	fixed ratings:	
REX12-TA1	1 A, 2 A, 3 A, 4 A, 6 A, 8 A, 10 A	
REX12-TA2	2 A / 2 A, 4 A / 4 A, 6 A / 6 A	
Visual status indication	green:	load circuit connected
by LED	green/orange blinking:	load current warning limit reached 80 %
	orange:	overload or short circuit until disconnection
	red:	- after disconnection due to overload or short circuit - after undervoltage release of operating voltage in ON condition with autoreset
	OFF:	Device switched off by means of ON/OFF momentary switch or no operating voltage

Load circuit		
Load output	power MOSFET switching output (plus switching)	
Load current warning limit (I <sub>WLimit</sub> )	typically 0.8 x I <sub>N</sub>	
hysteresis	typically 5 %	
Overload current disconnection (I <sub>OL</sub> ) with trip times (t <sub>OL</sub> )	typically I <sub>OL</sub> : I <sub>N</sub> x 1.05 typically I <sub>OL</sub> : I <sub>N</sub> x 1.35 typically I <sub>OL</sub> : I <sub>N</sub> x 2.00	t <sub>OL</sub> : 3s t <sub>OL</sub> : 0,5 s t <sub>OL</sub> : 0.1 s
Short circuit trip time (t <sub>SC</sub> )	typically I <sub>OL</sub> : I <sub>N</sub> x 2.50 typically at short circuit (I <sub>SC</sub> )	t <sub>OL</sub> : 0.012 s t <sub>SC</sub> : 0,002 s <sup>1)</sup>
Influence of ambient temperature on overload disconnection and load current warning limit	see temperature factor table	

**Technical data** ( $T_{amb} = +23\text{ °C}$ ,  $U_B = \text{DC } 24\text{ V}$ )

Fail-safe element integral blade fuse	$I_N: 1\text{ A}$	fail-safe $I_N: 1\text{ A}$
adjusted to related current rating $I_N$	$I_N: 2\text{ A}$	fail-safe $I_N: 2\text{ A}$
	$I_N: 3\text{ A}$	fail-safe $I_N: 3.15\text{ A}$
	$I_N: 4\text{ A}$	fail-safe $I_N: 4\text{ A}$
	$I_N: 6\text{ A}$	fail-safe $I_N: 6.3\text{ A}$
	$I_N: 8\text{ A}$	fail-safe $I_N: 8\text{ A}$
	$I_N: 10\text{ A}$	fail-safe $I_N: 10\text{ A}$
	$I_N: 2\text{ A} / 2\text{ A}$	fail-safe $I_N: 2\text{ A} / 2\text{ A}$
	$I_N: 4\text{ A} / 4\text{ A}$	fail-safe $I_N: 4\text{ A} / 4\text{ A}$
	$I_N: 6\text{ A} / 6\text{ A}$	fail-safe $I_N: 6.3\text{ A} / 6.3\text{ A}$

Voltage drop in load circuit at  $I_N$  and at  $I_N$  70 % between LINE+ and LOAD+

$I_N: 1\text{ A}$	typically 180 mV	$I_N: 70\%$	typically 125 mV
$I_N: 2\text{ A}$	typically 110 mV	$I_N: 70\%$	typically 80 mV
$I_N: 3\text{ A}$	typically 120 mV	$I_N: 70\%$	typically 85 mV
$I_N: 4\text{ A}$	typically 115 mV	$I_N: 70\%$	typically 80 mV
$I_N: 6\text{ A}$	typically 170 mV	$I_N: 70\%$	typically 110 mV
$I_N: 8\text{ A}$	typically 160 mV	$I_N: 70\%$	typically 105 mV
$I_N: 10\text{ A}$	typically 180 mV	$I_N: 70\%$	typically 120 mV

Operating voltage monitoring with regard to low voltage	OFF at typically $U_B < 16.0\text{ V}$ ON at typically $U_B > 17.5\text{ V}$ with automatic ON and OFF switching
---	--

Switch-on delay - with power ON	channel 1: typically 100 ms channel 2: typically 200 ms
---------------------------------	--

- when switching on via ON/OFF momentary switch or	channel 1: typically 5 ms channel 2: typically 100 ms
- after undervoltage	channel 1: typically 5 ms channel 2: typically 5 ms

Disconnection of load circuit	- manually on the device with the ON/OFF momentary switch - after an overload / short circuit disconnection with storage (no automatic reset) - temporarily at undervoltage - at no operating voltage
-------------------------------	--

Switch-on of load circuit - momentary switch ON/OFF	device can only be switched on when operating voltage is applied
- applying operating voltage	the device starts up with the condition last stored

Reset function	a blocked load output (blocked by overload / short circuit) can externally be reset by the ON/OFF momentary switch
----------------	--

Leakage current in load circuit in OFF condition	typically < 1 mA
--	------------------

Capacitive loads	up to 20,000 $\mu\text{F}$
------------------	----------------------------

Free-wheeling diode	external free-wheeling circuit at inductive load (rating according to load)
---------------------	---

Parallel connection of several load outputs	not allowed
---	-------------

<b>Status output</b>	
Status indication REX12-T	minus switching signal output group signalling is implemented in connection with EM12-T supply module

<b>Screw terminals</b>	<b>LOAD+</b>
Push-in terminal PT 2.5	0.14 mm <sup>2</sup> ...2.5 mm <sup>2</sup> , flexible
Stripping length	8 mm...10 mm
Dimensions (w x h x d)	12.5 x 98,5 x 80 mm

Mass	
REX12-TA1-xxx 1-channel	approx. 57 g
REX12-TA2-xxx 2-channel	approx. 58 g

**Technical data** ( $T_{amb} = +23\text{ °C}$ ,  $U_B = \text{DC } 24\text{ V}$ )

<b>General data</b>	
Housing material	moulded
Mounting	symmetrical rail to EN 60715-35x7.5
Ambient temperature	-25 °C...+60 °C (without condensation, cf. EN 60204-1)
Storage temperature	-40 °C...+70 °C
Mounting temperature	+5 °C...+60 °C
Humidity	96 hrs / 95% RH 40 °C to IEC 60068-2-78-Cab, climate class 3K3 to EN 60721
Vibration	3g test to IEC 60068-2-6, test Fc
Degree of protection	(IEC 60529, DIN VDE 0470) IP30
EMC requirements (EMC directive, CE logo)	noise emission EN 61000-6-3 susceptibility: EN 61000-6-2
Insulation co-ordination (IEC 60934)	0.5 kV / pollution degree 2
Dielectric strength	max. DC 30 V (load circuit)
Insulation resistance (OFF condition)	n/a, only electronic disconnection
Approvals	CE logo, UL 2367, File # E306740, (UL60947 / UL 508, File # E...) under preparation

**Ordering number code - REX12-T**

Type	REX12	Electronic circuit protector with PT connection technology	
Mounting method	T	rail mounting	
Design	A	1 load output terminal per channel, fixed current ratings xA or xA/xA	
Number of channels	1	1 channel	
	2	2 channels	
Version	1	without physical isolation	
Signal input	0	without signal input	
Signal output:	7	status output	
Operating voltage	DC 24 V	voltage rating DC 24 V	
Current ratings			
	1 A	(only 1-channel)	
	2 A	(only 1-channel)	
	3 A	(only 1-channel)	
	4 A	(only 1-channel)	
	6 A	(only 1-channel)	
	8 A	(only 1-channel)	
	10 A	(only 1-channel)	
	2 A/2 A	(only 2-channel)	
	4 A/4 A	(only 2-channel)	
	6 A/6 A	(only 2-channel)	
REX12 - T	A 1 - 1	0 7 - DC24V - 10 A	example of 1-channel
REX12 - T	A 2 - 1	0 7 - DC24V - 6 A / 6 A	example of 2-channel

**Preferred types**

Preferred types	Standard current ratings (A)						
<b>REX12-TA1</b>	2	4	6	10	2/2	4/4	6/6
REX12-TA1-107-DC24V-	x	x	x	x			
<b>REX12-TA2</b>	2	4	6	10	2/2	4/4	6/6
REX12-TA2-107-DC24V-					x	x	x

**Dimensions with connection diagram: REX12-TA1-xxx and REX12-TA2-xxx circuit protectors**

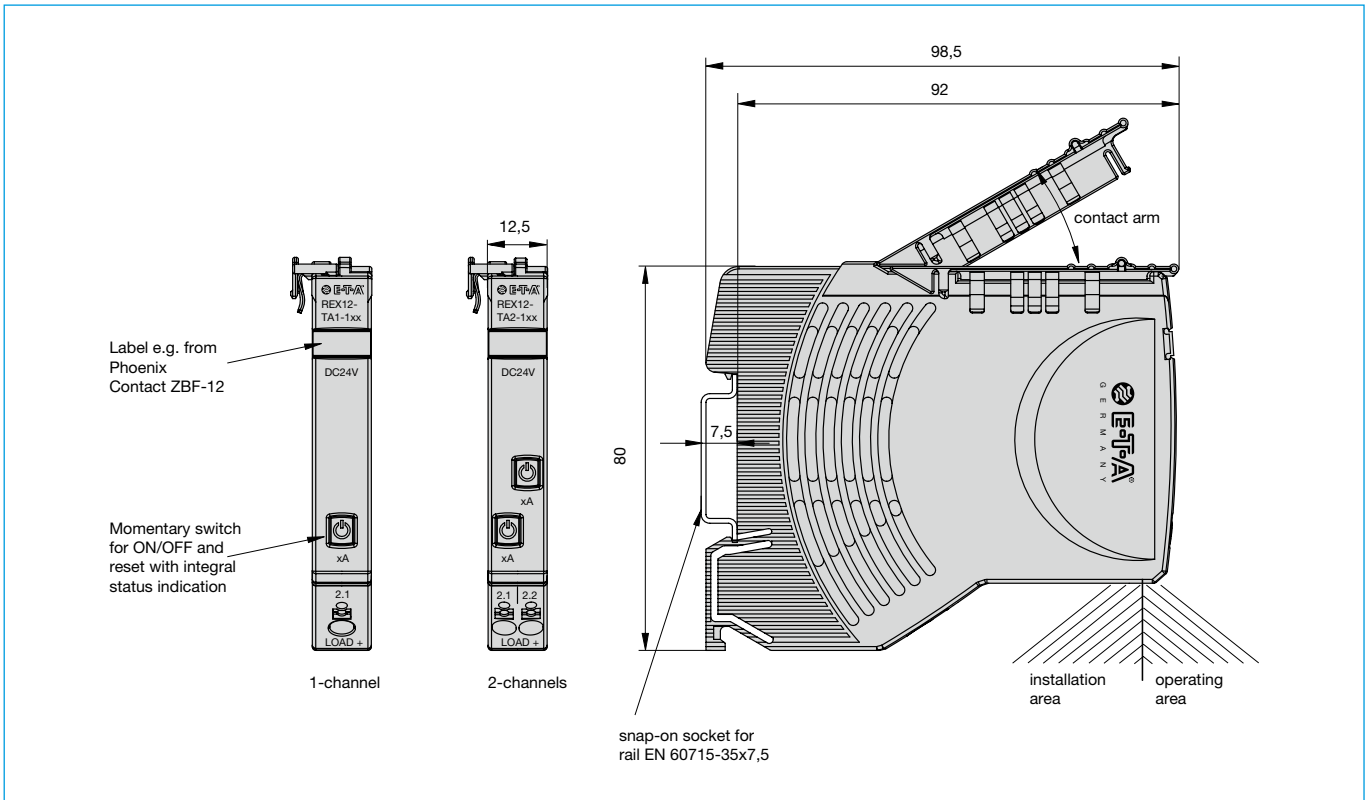

**Time/current characteristic ( $T_{amb} = +23\text{ °C}$ ,  $U_B = DC - 24\text{ V}$ )**

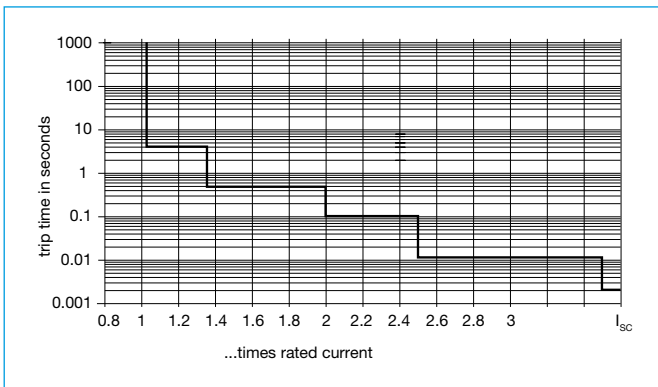

**Preferred mounting position REX12: horizontal**

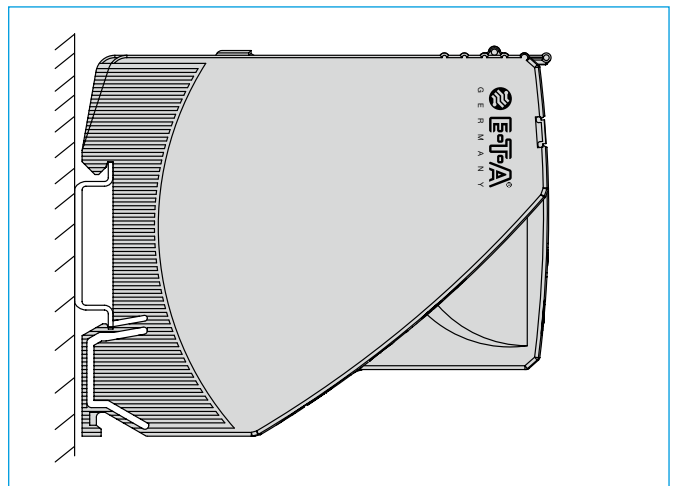

4

**Temperature factor / continuous duty**

The time/current characteristic depends on the ambient temperature. In order to avoid premature trip, the rating of the circuit protector has to be multiplied with a temperature factor and has to be accounted for when mounted side-by-side (see chapter Technical Information).

**Temperature factor table:**

ambient temperature [°C]	0	10	23	40	50	60
temperature factor	1	1	1	0,95	0,90	0,85

Note: When mounted side-by-side, the devices can carry max. 80 % of their rated load or a different rating has to be selected (see chapter Technical Information).

Note:

With high temperatures, the load current warning threshold “warn limit typically  $0.8 \times I_N$ ” will be reduced in accordance with the temperature factor.

**Description – EM12-T supply module**

The EM12-T supply module receives the DC 24 V supply voltage, e.g. from a switched mode power supply, and distributes it to the mounted circuit protectors via the integral connector arm of the REX12-T. The potential-free auxiliary contact in the EM12-T indicates any detected failures through the circuit protector, e.g. to the superordinate control unit (CPU).

**Technical data (T<sub>amb</sub> = +23 °C, U<sub>B</sub> = DC 24 V)**

Operating voltage U <sub>B</sub>	DC 24 V (18...30 V)
Operating current I <sub>B</sub>	max. 40 A
Reverse polarity protection	yes
Quiescent current I <sub>0</sub>	typically 10 mA
Potential-free auxiliary change-over contact	max. DC 30 V / 0.5 A min. 10 V / 1 mA
Group signalling Si	auxiliary contact, make contact
Contact: Si (13) / Si (14)	
normal condition:	auxiliary contact closed - when ON, load output connected - when OFF, load output disconnected
fault condition:	auxiliary contact open - after an overload or short circuit disconnection - after undervoltage release of operating voltage in ON condition with autoreset - at no operating voltage U <sub>B</sub> in supply module
Insulation co-ordination	0.5 kV / pollution degree 2
Power failure buffering time	up to 10 ms
<b>Screw terminals</b>	<b>LINE+</b>
Push-in terminal PT 10	0.5 mm <sup>2</sup> ...10 mm <sup>2</sup> , flexible
Stripping length	18 mm...10 mm
<b>Screw terminals</b>	<b>0 V / Si 13 / Si 14</b>
Push-in terminal PT 2.5	0.14 mm <sup>2</sup> ...2.5 mm <sup>2</sup> , flexible
Stripping length	8 mm...10 mm
Dimensions (w x h x d)	12.5 x 98 x 80 mm
Mass	approx. 52 g
Number of circuit protectors to be mounted side-by-side to EM12 REX12-TA1-x or REX12-TA2-x	max. 16 pcs

**Dimensions EM12-Txx supply module**

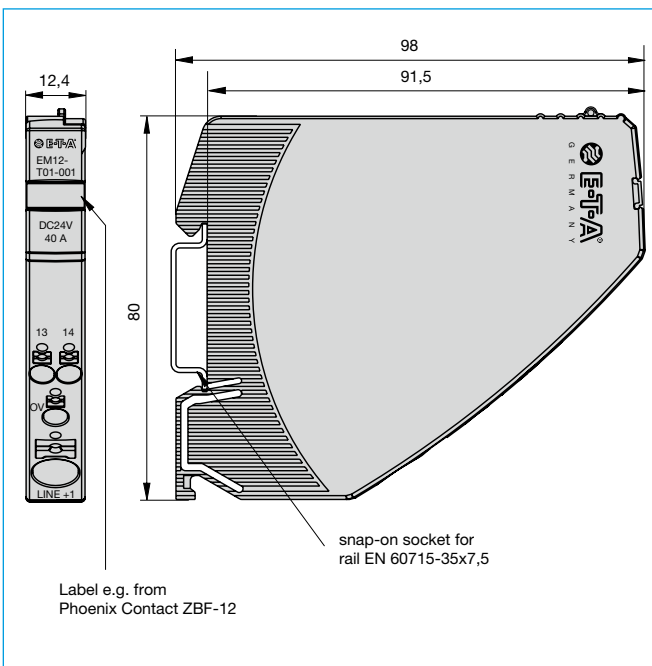

**Schematic diagram EM12-Txx with REX12-xx**

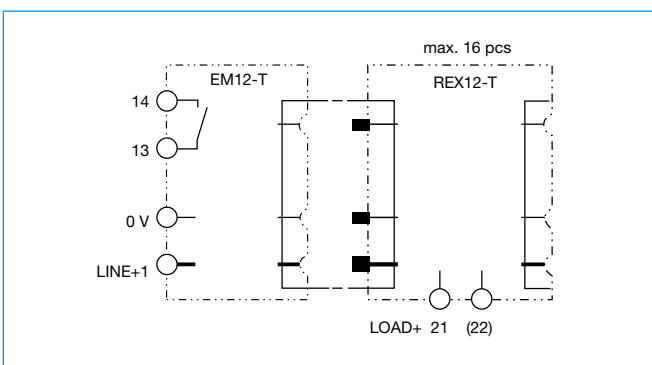

**Ordering number code – EM12**

Type	EM12	supply module for REX, with PT connection technology
Mounting method	T	rail mounting
Version: communication, interface	01	analog signal
Additional functionality	0	without
Signal input:	0	without signal input
Signal output:	1	signal make contact
Operating voltage	DC 24 V	voltage rating DC 24 V
Current ratings	40 A	
Ordering example	EM12 - T 01 - 0 0 1 - DC 24 V - 40 A	

Application example: REX... mounting on or removing from symmetrical rail

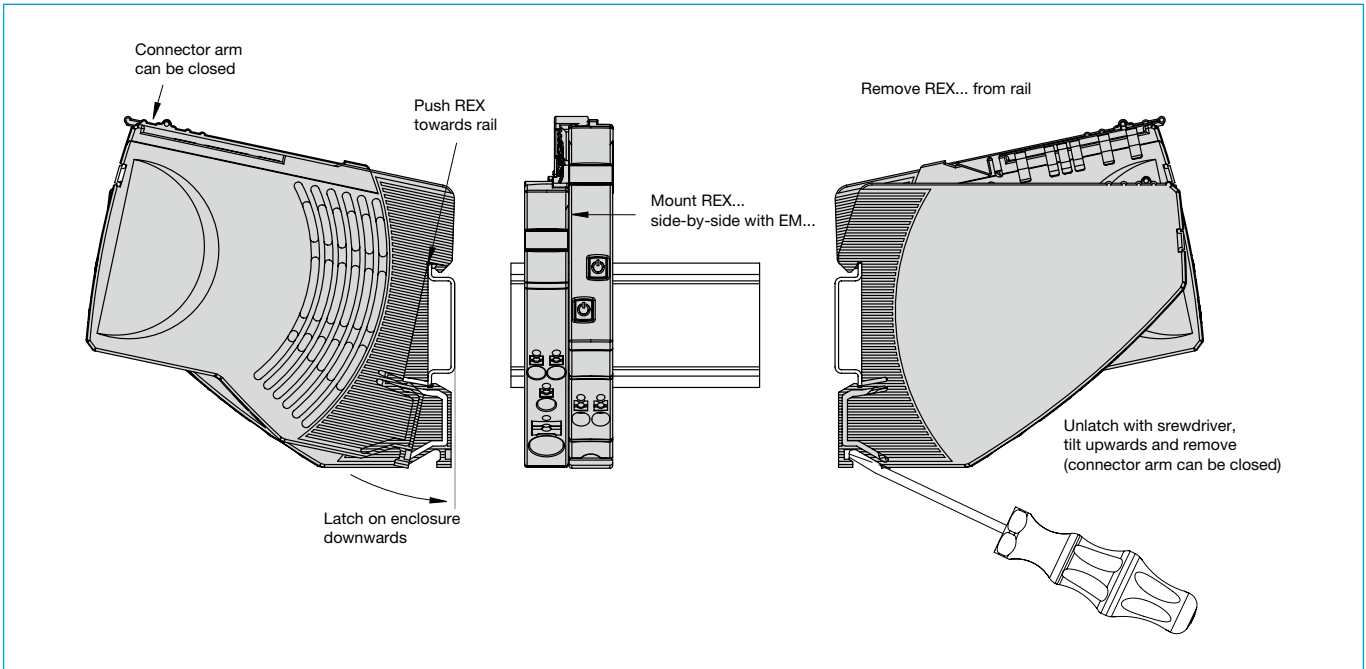

Application example: REX... replacement or disassembly

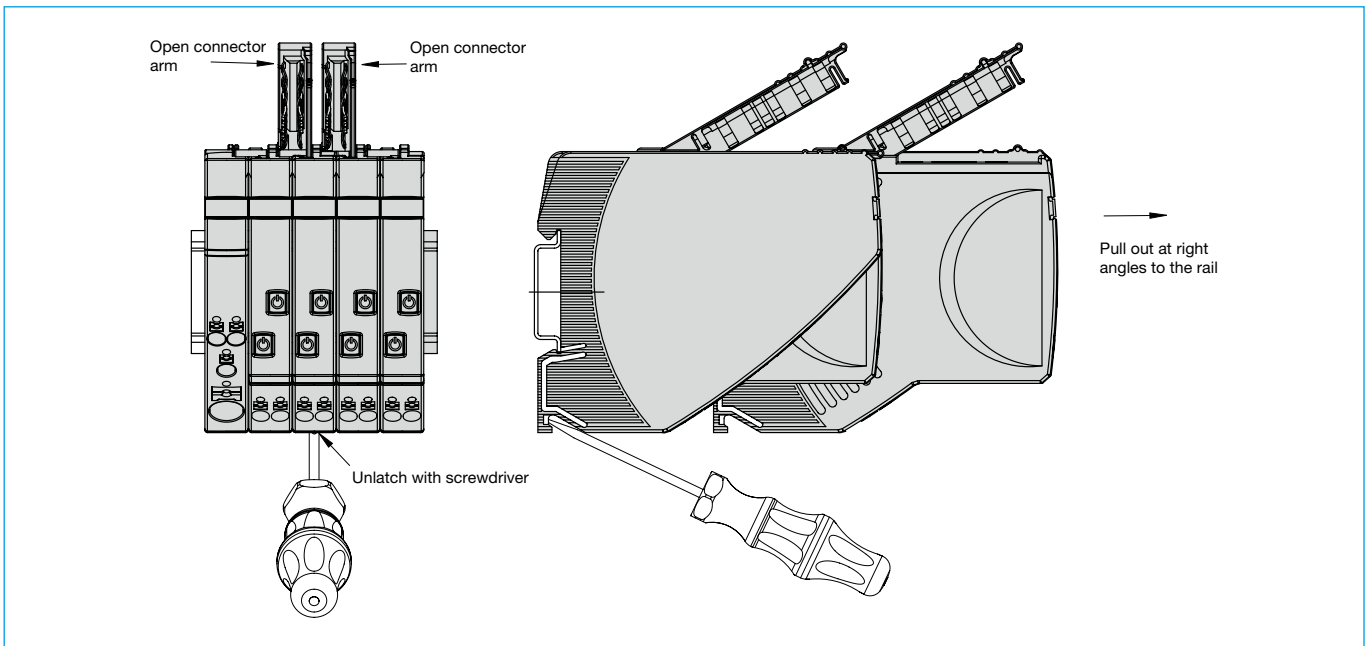

Instructions for installation

Mounting or actuation of the REX connector arm must only be effected at dead-voltage. For start-up the REX connector arm must be closed.

**Application example: EM12-T with REX12-TA1... and REX12-TA2...**

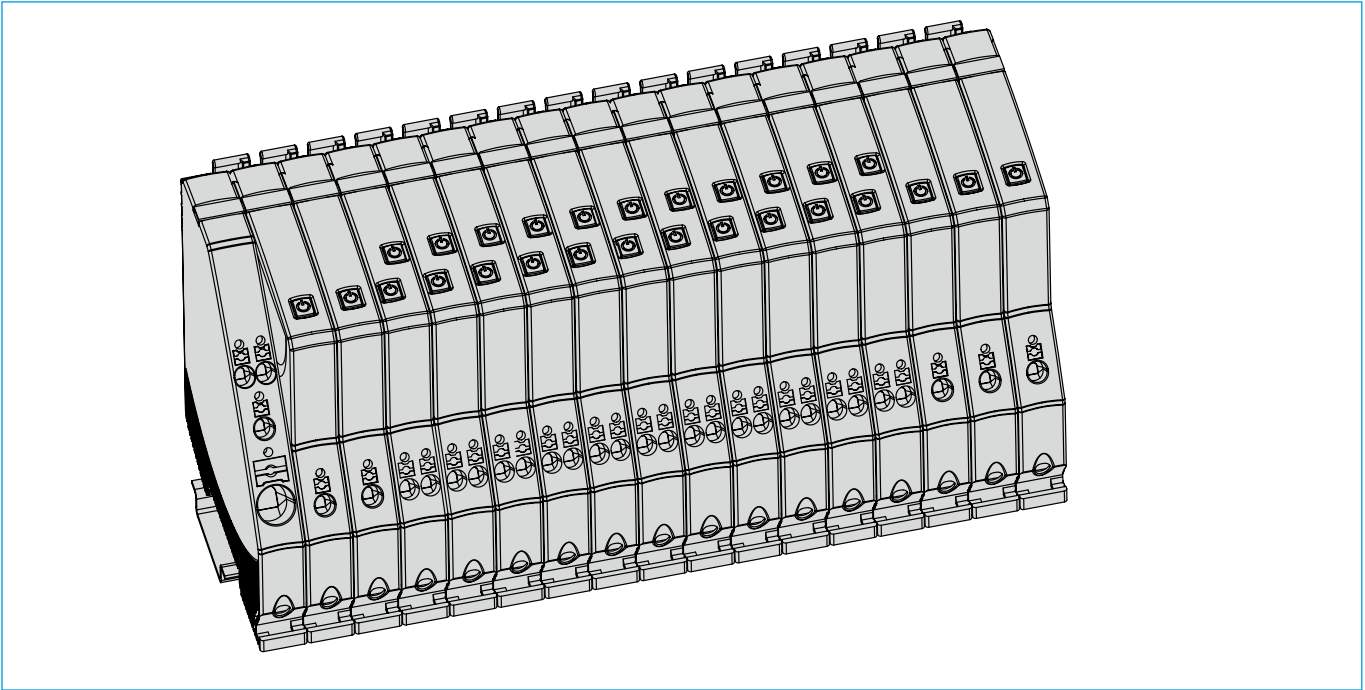

**Application example: REX... Locked connector arms**

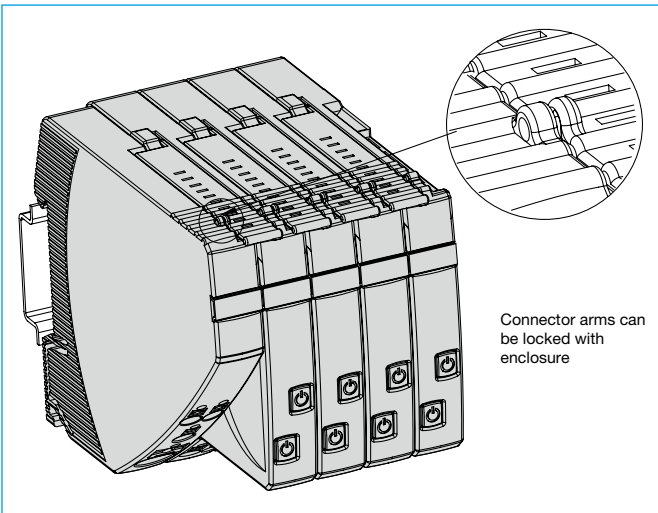

**Application example: REX12(D)-T... distance between cable duct and connector arm**

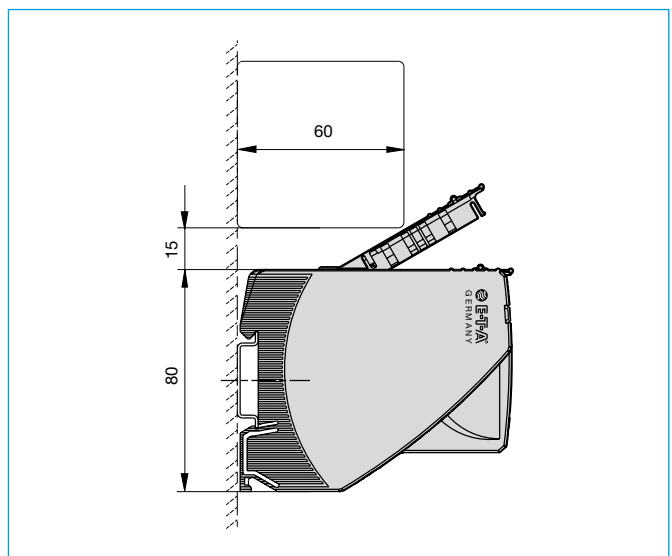

4

All dimensions without tolerances are for reference only. E-T-A reserves the right change specifications at any time in the interest of improved design, performance and cost effectiveness, the right to make changes in these specifications without notice is reserved. Product markings may not be exactly as the ordering codes. Errors and omissions excepted.