

# Pin(THT) Power Inductor

## DEP1519B



### Description

- Magnetically shielded.
- Flat wire windings provide exceptionally low DC resistance.
- LxWxH:15.5x18.0x19.3mm Max.
- Product weight:19.3g (Ref.)
- Moisture Sensitivity Level: 1

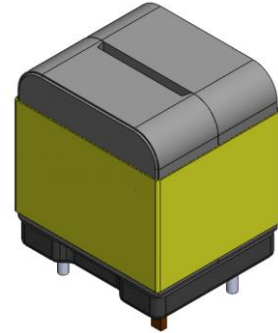

### Applications

- Best suited as LPF inductor for compact Digital Amplifier(Class-D-Amp).
- Designed for high current power supply application.
- DC/DC converters in distributed power systems

### Environmental Data

- Operating temperature range: -40°C~+125°C(including coil's self temperature rise)
- Storage temperature range: -40°C~+125°C

### Packaging

- Pallet and box packaging (200pcs/box).
- 50pcs per pallet.

### Dimensions - [mm]

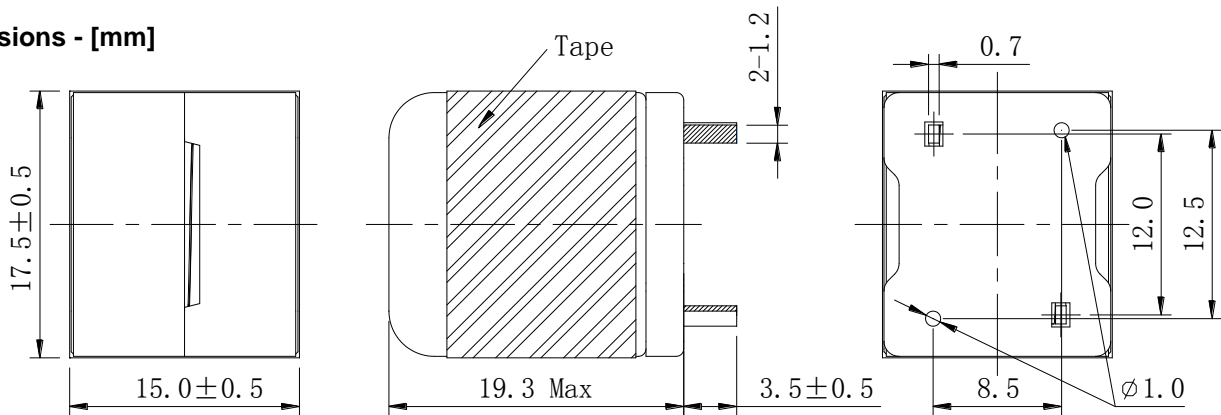

### Land patterns and Schematics- [mm]

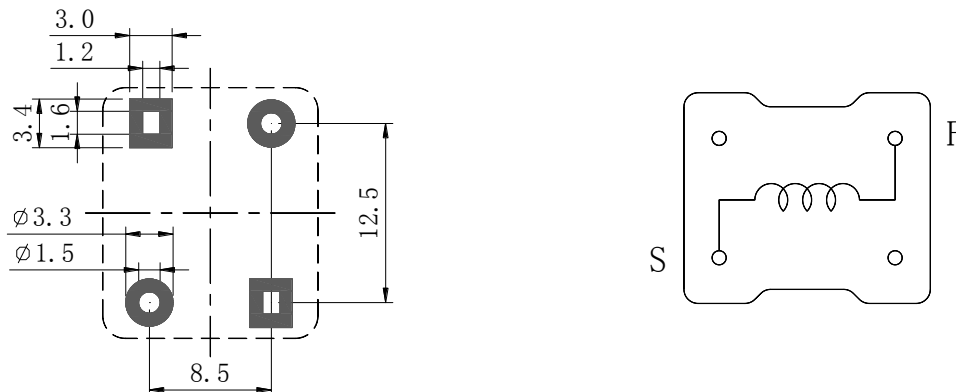

Note: This specification is subject to change without notice. Please contact your nearest sales office for updated information when placing an order.

# Pin(THT) Power Inductor

## DEP1519B



### Electrical Characteristics

Part No.	Stamp	Inductance [Within] ( $\mu$ H)※1 (1-2);(3-4)	D.C.R(m $\Omega$ ) Max.(Typ.) at 25°C (1-2);(3-4)	Saturation Current(A)※2 Max.(Typ.) (1-2);(3-4)	Temperature rise current (A) Typ. ※3 (1-2);(3-4)
DEP1519BHF-100M	100M	10.0 $\pm$ 20%	10.7(9.2)	26.0(32.7)	10.0 (11.2)
DEP1519BHF-150M	150M	15.0 $\pm$ 20%	10.7(9.2)	18.8(23.5)	10.0 (11.2)
DEP1519BHF-220M	220M	22.0 $\pm$ 20%	10.7(9.2)	13.2(16.5)	10.0 (11.2)
DEP1519BHF-330M	330M	33.0 $\pm$ 20%	10.7(9.2)	9.4(11.8)	10.0 (11.2)

※1 Measuring frequency Inductance at 1kHz,1V

※2 Saturation current: The value of DC current when the inductance is over 75% of its initial value. (at 25°C )

※3 Temperature rise current: The actual value of DC current when temperature of coil rise is  $\Delta T=40^{\circ}\text{C}$ ( $T_a=25^{\circ}\text{C}$ )

# Pin(THT) Power Inductor

## DEP1519B



### Saturation Current & Temperature Rise Graph

— L (25°C) —  $\Delta T$

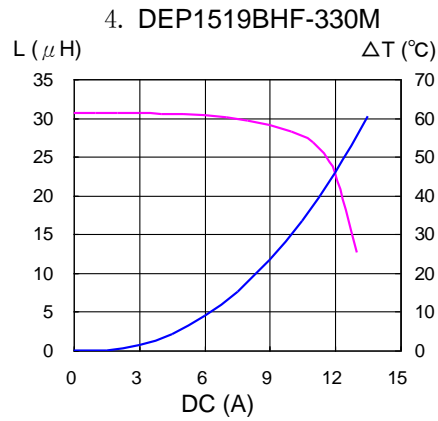
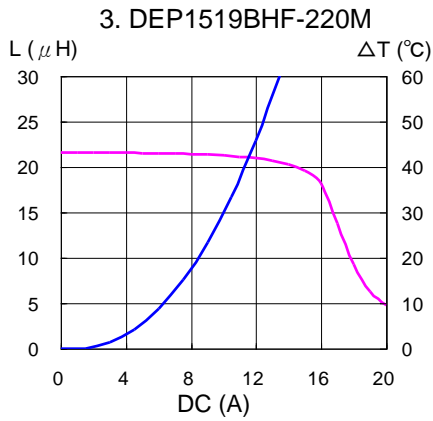
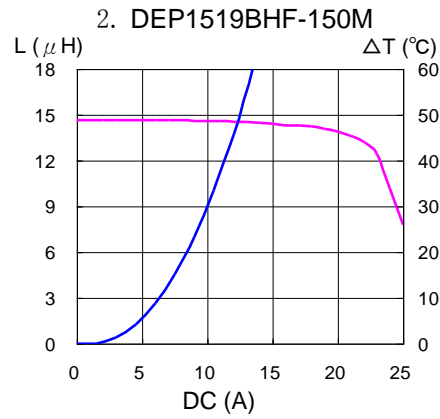
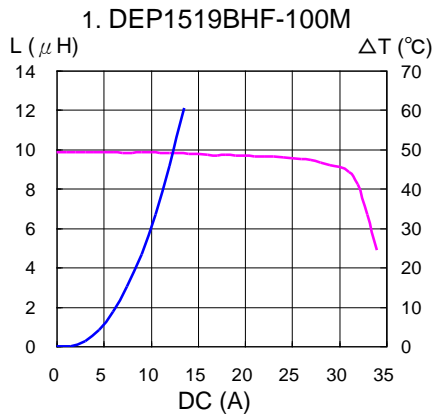

For sales office information, please [click here](#) to visit our website.

Note: This specification is subject to change without notice. Please contact your nearest sales office for updated information when placing an order.