

OV2281 1080p product brief



Biometric Security for Next-Generation Smartphones, Tablets, and Notebooks



available in
a lead-free
package

OmniVision's OV2281 is a PureCel® sensor that brings enhanced biometric security functionality to mobile devices. The low-power, ultra-compact OV2281 leverages a 1.12-micron pixel with PureCel technology to enable accurate, reliable iris recognition for smartphones, tablets, and notebooks.

The 1/7.5-inch OV2281 PureCel sensor can record 1080p high-definition (HD) video at 60 frames per second (fps) in both landscape and portrait modes to support apps with horizontal or vertical orientation.

When recording full-resolution 1944 x 1944 video at 30 fps, the sensor requires just 126 mW, and supports ultra-low power mode to reduce power consumption to approximately 25 mW. Additionally, the OV2281 features optimized IR sensitivity to produce a clear, fully stable image in difficult, low-light conditions.

The OV2281 sensor fits into a 5.5 x 5.5 mm module with a z-height of less than 4.5 mm.

Find out more at www.ovt.com.



Applications

- Smartphones and Feature Phones
- Tablets
- PC Multimedia
- Wearables

Product Features

- 1.12 μm x 1.12 μm pixel
- 1920x1080 at 60 fps, 1080x1920 at 30 fps
- programmable controls for:
 - frame rate
 - mirror and flip
 - cropping
 - windowing
- supports images sizes:
 - 1944x1944
 - 1080p (1920x1080)
 - 1080x1920, and more
- 260 bytes of embedded one-time programmable (OTP) memory for customer use
- ultra low power mode (ULPM)
- support for output formats: 10-bit B&W RAW
- interleave row HDR output
- two-wire serial bus control (SCCB)
- MIPI serial output interface (1- or 2-lane)
- 2x binning support
- image quality control:
 - defect pixel correction
 - automatic black level calibration

OV2281



Ordering Information

- OV02281-GA4A**
(B&W, chip probing, 200 μm backgrinding, reconstructed wafer)

Product Specifications

- active array size:** 1944 x 1944
- power supply:**
 - core: 1.14 to 1.26V (1.2V nominal)
 - analog: 2.6 to 3.0V (2.8V nominal)
 - I/O: 1.7 to 1.9V (1.8V nominal)
- power requirements:**
 - active: 126 mW
 - standby: 166 μW
 - XSHUTDOWN: 1 μW
- temperature range:**
 - operating: -30°C to +85°C junction temperature
 - stable image: -20°C to +60°C junction temperature
- output interface:** 2-lane MIPI serial output
- output formats:** 10-bit B&W RAW
- lens size:** 1/7.5"
- input clock frequency:** 6 - 27 MHz
- lens chief ray angle:** 30.9° non-linear
- maximum image transfer rate:**
 - 1944x1944: 30 fps
 - 1080p (1920x1080): 60 fps
 - 1080x1920: 30 fps
- sensitivity:** 555 mV/lux-sec
- max S/N ratio:** 35.6 dB
- dynamic range:** 68.4 dB @ 16x gain
- pixel size:** 1.12 μm x 1.12 μm
- dark current:** 14 e⁻/sec @ 60°C junction temperature
- image area:** 2214 μm x 2214 μm
- die dimensions:**
 - COB: 4050 μm x 3400.2 μm
 - RW: 4100 μm x 3450.2 μm

Functional Block Diagram

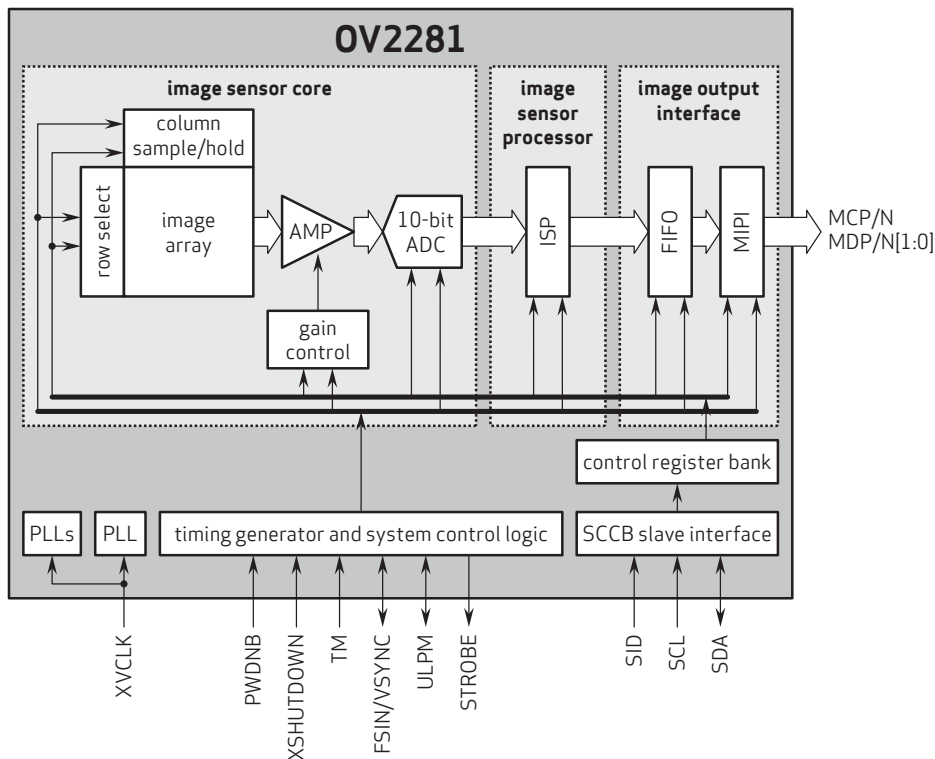

4275 Burton Drive
Santa Clara, CA 95054
USA

Tel: + 1 408 567 3000
Fax: + 1 408 567 3001
www.ovt.com

OmniVision reserves the right to make changes to their products or to discontinue any product or service without further notice. OmniVision, the OmniVision logo and PureCel are registered trademarks of OmniVision Technologies, Inc. All other trademarks are the property of their respective owners.



OmniVision