



# IR Emitter and Detector Product Data Sheet

LTE-7072-M-TA

Spec No.: DS50-2015-0176

Effective Date: 01/16/2016

Revision: -

**LITE-ON DCC**

**RELEASE**

BNS-OD-FC001/A4

## IR Emitter and Detector LTE-7072-M-TA

### 1. Description

Lite-On offers a broad range of discrete infrared components for application such as remote controller, IR wireless data transmission, security alarm & etc. The product line includes GaAs 940nm IREDs, AlGaAs high power 880nm IREDs, AlGaAs high speed 875nm/850nm IREDs, PIN Photodiodes, Phototransistor and Photodarlington.

#### 1.1. Features

- Lead (Pb) free product and RoHS compliant.
- High speed.
- Wide radiation angle.
- Available for pulse operating
- Flat and small package.
- Clear transparent lens.
- "Z" lead forming

#### 1.2. Applications

- Interactive white board
- IR touch

### 2. Outline Dimensions

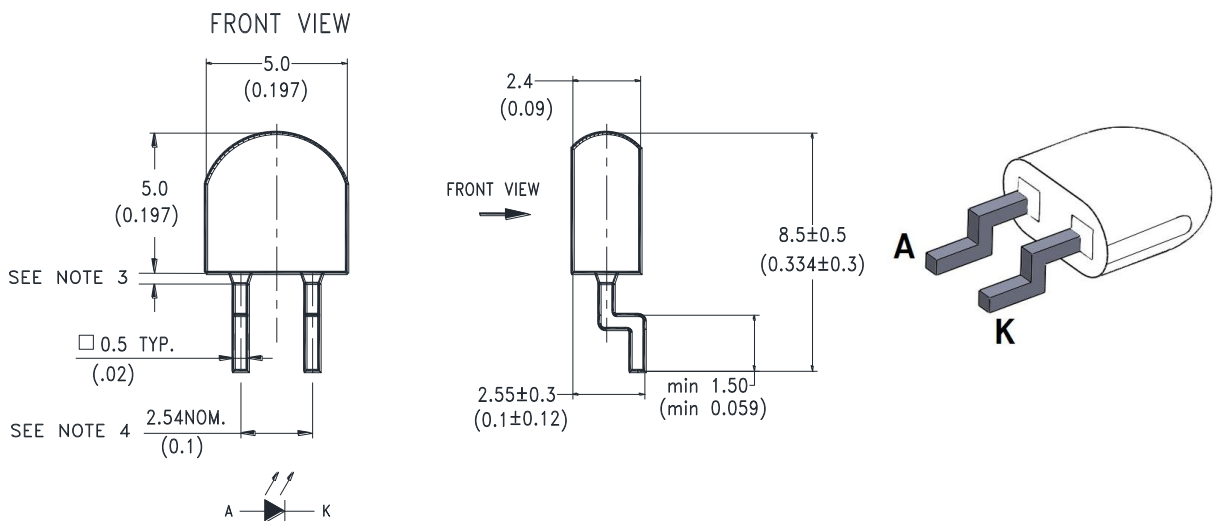

#### Notes :

1. All dimensions are in millimeters (inches).
2. Tolerance is ±0.25mm (.010") unless otherwise noted.
3. Protruded resin under flange is 1.0mm (.04") max.
4. Lead spacing is measured where the leads emerge from the package.
5. Specifications are subject to change without notice.
6. Manufacturing site: Thailand and ChangZhou

## IR Emitter and Detector LTE-7072-M-TA

### 3. Absolute Maximum Ratings at TA=25°C

| Parameter   | Maximum Rating                 | Unit |
|---|--------------------------------|------|
| Power Dissipation                                       | 150                            | mW   |
| Peak Forward Current<br>(300pps, 10µs pulse)            | 2                              | A    |
| Continuous Forward Current                              | 100                            | mA   |
| Reverse Voltage   | 5                              | V    |
| Operating Temperature Range                             | -40°C to + 85°C                |      |
| Storage Temperature Range                               | -40°C to + 100°C               |      |
| Lead Soldering Temperature<br>[1.6mm (.063") From Body] | 260°C for 5 Seconds            |      |
| IR reflow Soldering Temperature                         | Peak temperature 200°C, ≤30sec |      |

### 4. Electrical / Optical Characteristics at TA=25°C

| Parameter                | Symbol                | Min. | Typ. | Max. | Unit   | Test Condition           |
|--------------------------|-----------------------|------|------|------|--------|--------------------------|
| Radiant Intensity        | I <sub>e</sub>        | 2.0  | 4.0  |      | mW/sr  | IF = 20mA                |
| Peak Emission Wavelength | λ <sub>P</sub>        |      | 940  |      | nm     | IF = 20mA                |
| Spectral Line Half-Width | Δλ                    |      | 50   |      | nm     | IF = 20mA                |
| Forward Voltage          | V <sub>F</sub>        |      | 1.2  | 1.6  | V      | IF = 20mA                |
| Reverse Current          | I <sub>R</sub>        |      |      | 100  | µA     | VR = 5V                  |
| Viewing Angle            | 2θ <sub>1/2</sub> (X) |      | 80   |      | degree | IF = 20mA<br>(See Fig.6) |
|                          | 2θ <sub>1/2</sub> (Y) |      | 40   |      |        |                          |

# IR Emitter and Detector LTE-7072-M-TA

## 5. Typical Electrical / Optical Characteristics Curves

(25°C Ambient Temperature Unless Otherwise Noted)

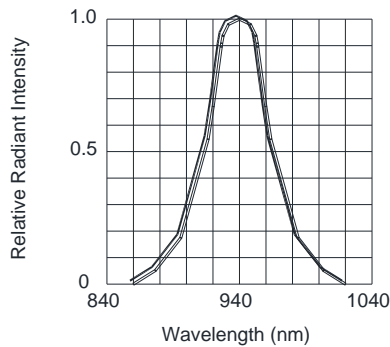

FIG.1 SPECTRAL DISTRIBUTION

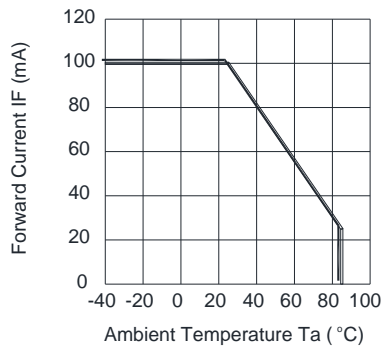

FIG.2 FORWARD CURRENT VS. AMBIENT TEMPERATURE

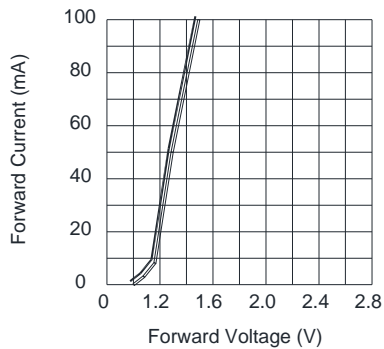

FIG.3 FORWARD CURRENT VS. FORWARD VOLTAGE

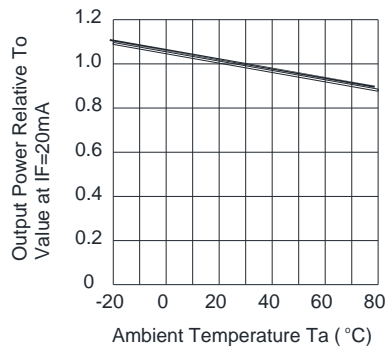

FIG.4 RELATIVE RADIANT INTENSITY VS. AMBIENT TEMPERATURE

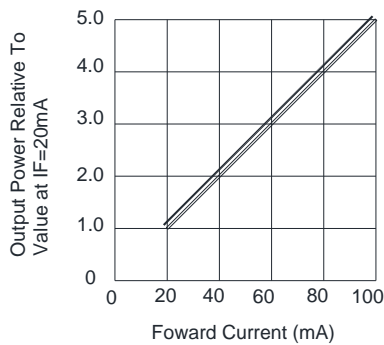

FIG.5 RELATIVE RADIANT INTENSITY VS. FORWARD CURRENT

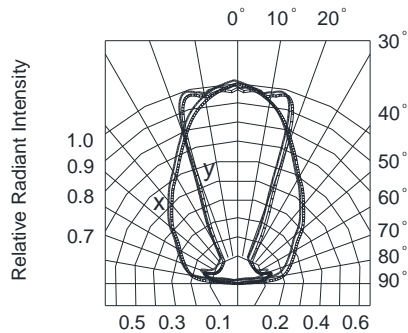
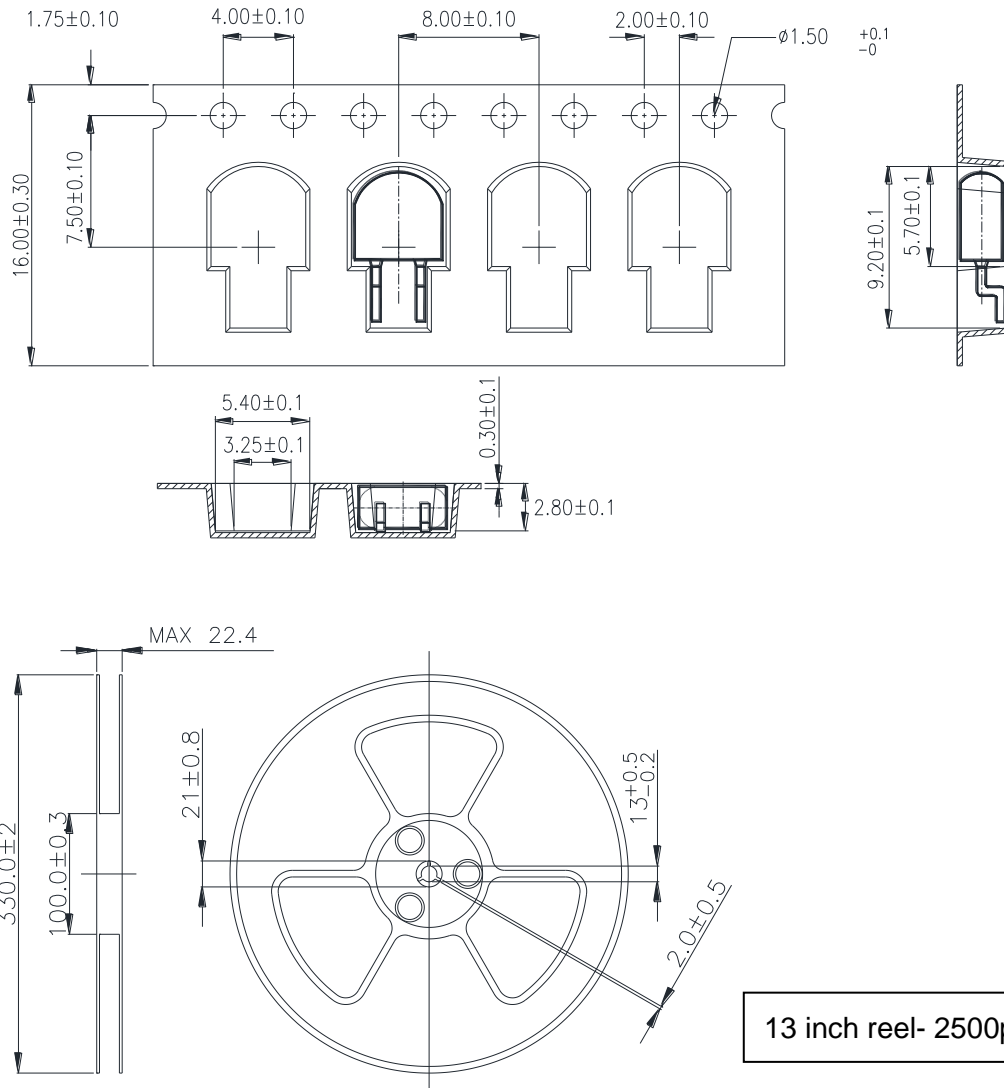

FIG.6 RADIATION DIAGRAM

**IR Emitter and Detector**  
**LTE-7072-M-TA**

**6. Packing Dimension of Tape and Reel**



13 inch reel- 2500pieces/ reel

**NOTE:**

1. All dimensions are in millimeter.
2. 10 sprocket hole pitch cumulative tolerance is  $\pm 0.2$ mm.
3. The maximum number of consecutive missing lamp is two.
4. Empty component pockets sealed with top cover tape.
5. All dimensions meet EIA-48-D requirement, unless customer has special requests.

## IR Emitter and Detector LTE-7072-M-TA

### 7. Suggest soldering pad and dimension

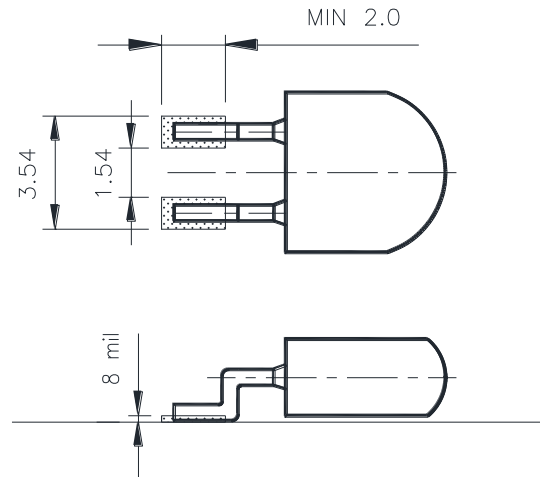

## 8. CAUTIONS

### 8.1. Application

The LEDs described here are intended to be used for ordinary electronic equipment (such as office equipment, communication equipment and household applications). Consult Liteon's Sales in advance for information on applications in which exceptional reliability is required, particularly when the failure or malfunction of the LEDs may directly jeopardize life or health (such as in aviation, transportation, traffic control equipment, medical and life support systems and safety devices).

### 8.2. Storage

The storage ambient for the LEDs should not exceed 30°C temperature or 70% relative humidity. It is recommended that LEDs out of their original packaging are used within three months. For extended storage out of their original packaging, it is recommended that the LEDs be stored in a sealed container with appropriate desiccant or in desiccators with nitrogen ambient.

### 8.3. Cleaning

Use alcohol-based cleaning solvents such as isopropyl alcohol to clean the LEDs if necessary.

### 8.4. Lead Forming & Assembly

During lead forming, the leads should be bent at a point at least 3mm from the base of LED lens. Do not use the base of the lead frame as a fulcrum during forming. Lead forming must be done before soldering, at normal temperature. During assembly on PCB, use minimum clinch force possible to avoid excessive mechanical stress.

### 8.5. Soldering

When soldering, leave a minimum of 3mm clearance from the base of the lens to the soldering point. Dipping the lens into the solder must be avoided. Do not apply any external stress to the lead frame during soldering while the LED is at high temperature.

### 8.6. Drive Method

An LED is a current-operated device. In order to ensure intensity uniformity on multiple LEDs connected in parallel in an application, it is recommended that a current limiting resistor be incorporated in the drive circuit, in series with each LED as shown in Circuit A below.

## IR Emitter and Detector LTE-7072-M-TA

Circuit model (A)

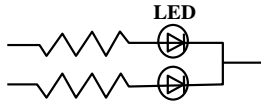

Circuit model (B)

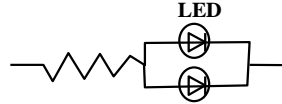

(A) Recommended circuit

(B) The brightness of each LED might appear different due to the differences in the I-V characteristics of those LEDs.

### 8.7. ESD (Electrostatic Discharge)

#### Static Electricity or power surge will damage the LED.

##### Suggestions to prevent ESD damage:

- Use a conductive wrist band or anti- electrostatic glove when handling these LEDs
- All devices, equipment, and machinery must be properly grounded
- Work tables, storage racks, etc. should be properly grounded
- Use ion blower to neutralize the static charge which might have built up on surface of the LEDs plastic lens as a result of friction between LEDs during storage and handing

##### Suggested checking list:

##### Training and Certification

- 8.7.1.1. Everyone working in a static-safe area is ESD-certified?
- 8.7.1.2. Training records kept and re-certification dates monitored?

##### Static-Safe Workstation & Work Areas

- 8.7.2.1. Static-safe workstation or work-areas have ESD signs?
- 8.7.2.2. All surfaces and objects at all static-safe workstation and within 1 ft measure less than 100V?
- 8.7.2.3. All ionizer activated, positioned towards the units?
- 8.7.2.4. Each work surface mats grounding is good?

##### Personnel Grounding

- 8.7.3.1. Every person (including visitors) handling ESD sensitive (ESDS) items wear wrist strap, heel strap or conductive shoes with conductive flooring?
- 8.7.3.1. If conductive footwear used, conductive flooring also present where operator stand or walk?
- 8.7.3.2. Garments, hairs or anything closer than 1 ft to ESD items measure less than 100V\*?
- 8.7.3.3. Every wrist strap or heel strap/conductive shoes checked daily and result recorded for all DLs?
- 8.7.3.4. All wrist strap or heel strap checkers calibration up to date?

Note: \*50V for Blue LED.

##### Device Handling

- 8.7.4.1. Every ESDS items identified by EIA-471 labels on item or packaging?
- 8.7.4.2. All ESDS items completely inside properly closed static-shielding containers when not at static-safe workstation?
- 8.7.4.3. No static charge generators (e.g. plastics) inside shielding containers with ESDS items?
- 8.7.4.4. All flexible conductive and dissipative package materials inspected before reuse or recycle?

##### Others

- 8.7.5.1. Audit result reported to entity ESD control coordinator?
- 8.7.5.2. Corrective action from previous audits completed?
- 8.7.5.3. Are audit records complete and on file?

## IR Emitter and Detector LTE-7072-M-TA

### 9. Reliability Test

| Classification     | Test Item                                    | Test Condition   | Reference Standard   |
|--------------------|--|--|--|
| Endurance Test     | Operation Life                               | Ta= Under Room Temperature As<br>Per Data Sheet Maximum Rating<br>Test Time= 1000HRS                             | MIL-STD-750D:1026 (1995)<br>MIL-STD-883G:1005 (2006)   |
|                    | High Temperature<br>High Humidity<br>storage | Ta= 65°C<br>RH= 95%<br>Test Time= 240HRS   | MIL-STD-202G:103B (2002)<br>JEITA ED-4701:100 103 (2001)   |
|                    | High Temperature<br>Storage                  | Ta= 105±5°C<br>Test Time= 1000HRS  | MIL-STD-750D:1031 (1995)<br>MIL-STD-883G:1008 (2006)<br>JEITA ED-4701:200 201 (2001)                         |
|                    | Low Temperature<br>Storage                   | Ta= -40±5°C<br>Test Time=1000HRS   | JEITA ED-4701:200 202 (2001)   |
| Environmental Test | Temperature<br>Cycling                       | -40°C ~ 25°C ~ 105°C ~ 25°C<br>30mins 5mins 30mins 5mins<br>Test time: 30 Cycles                                 | MIL-STD-750D:1051 (1995)<br>MIL-STD-883G:1010 (2006)<br>JEITA ED-4701:100 105 (2001)<br>JESD22-A104C (2005)  |
|                    | Thermal<br>Shock                             | 105 ± 5°C ~ -40°C ± 5°C<br>10mins 10mins<br>Test time: 20 Cycles   | MIL-STD-750D:1056 (1995)<br>MIL-STD-883G:1011 (2006)<br>MIL-STD-202G:107G (2002)<br>JESD22-A106B (2004)      |
|                    | Solder<br>Resistance                         | T.sol = 260 ± 5°C<br>Dwell Time= 10±1 seconds<br>3mm from the base of the epoxy bulb                             | MIL-STD-750D:2031(1995)<br>JEITA ED-4701: 300 302 (2001)   |
|                    | Solderability                                | T. sol = 245 ± 5°C<br>Dwell Time= 5 ± 0.5 seconds<br>(Lead Free Solder, Coverage ≥ 95% of<br>the dipped surface) | MIL-STD-750D:2026 (1995)<br>MIL-STD-883G:2003 (2006)<br>MIL-STD-202G:208H (2002)<br>IPC/EIA J-STD-002 (2004) |

### 10. Others

The appearance and specifications of the product may be modified for improvement without prior notice.