

FEATURES

- Up to 1A Output Current
- 70uA Operating Supply Current
- Excellent Line Regulation: 0.05%/V
- Low Dropout: 350mV@1A(VOUT=3.3V)
- High Power Supply Rejection Ratio
- Wide Operating Voltage Range: 2.5V to 6.0V
- 1V to 5V Factory-Preset Output
- High Accuracy: $\pm 1\%$ or $\pm 2\%$
- Built-in Auto Discharge Function
- 500mA in-rush Current Limit
- Fold-back Current Limit Protection
- Thermal Shutdown Protection
- DFN-6, SOT-89-5, SOT-89-3, SOT-223-5, SOT-223-3, TO-263-3, TO-220-3, TO-252-3 and TO-252-5 Package
- RoHS Compliant and 100% Lead (Pb)-Free

APPLICATIONS

- Portable Communication Equipment
- Battery-Powered Equipment
- Laptop, Palmtops, Notebook Computers
- Hand-Held Instruments

- PCMCIA Cards and Wireless LAN
- Electrical appliances such as cameras, VCRS

DESCRIPTION

The BL9110 is a low-dropout regulator that operates the input voltage from 2.5V to 6V and delivers 1A load current. The BL9110 is available in two types, either fixed or adjustable output voltage. The output voltage of the fixed types is preset at an internally trimmed voltage 1V, 1.2V, 1.3V, 1.5V, 1.8V, 2.5V, 2.7V, 2.8V, 2.85V, 3.0V, 3.2V, 3.3V, 5V or can be made with options of the output range from 1V to 5V in 50mV increments. The output range of adjustable types is from 1V to 5V. The BL9110 consists of a voltage reference, an error amplifier, resistor net for setting output voltage, a current limit circuit for over-current and a thermal-shutdown circuit.

A standby mode with ultra low supply current can be realized with the chip enable function. Since the packages for BL9110 are DFN-6, SOT-89-5, SOT-223-5, SOT-223-3, TO-263-3, TO-220-3, SOT-89-3, TO-252-3, TO92-3 and TO-252-5 with high power dissipation, high density mounting of the IC on board is possible.

ORDERING INFORMATION

BL9110-VVV X X XX



Package:
 AA: DFN-6
 BA: SOT-89-5-A
 CA: TO-252-5
 DA: SOT-223-5
 EA: TO-252-3-A
 FA: SOT-223-3-A
 FC: SOT-223-3-C
 GA: TO-263-3-A
 GC: TO-263-3-C
 HA: TO-220-3
 IA: SOT-89-3-A
 IC: SOT-89-3-C
 JA: TO92-3
 BB: SOT-89-5-B
 EB: TO-252-3-B
 FB: SOT-223-3-B
 FD: SOT-223-3-D
 GB: TO-263-3-B
 IB: SOT-89-3-B

Features:
 P: Standard (default, lead free)
 C: Customized

Output Voltage Accuracy
 A: $\pm 1\%$
 B: $\pm 2\%$

Output Voltage
 100:1.0V 120:1.2V 130:1.3V 150:1.5V
 180:1.8V 250:2.5V 270:2.7V 280:2.8V
 285:2.85V 300:3.0V 320:3.2V 330:3.3V
 500:5.0V
 ADJ: adjustable

TYPICAL APPLICATION

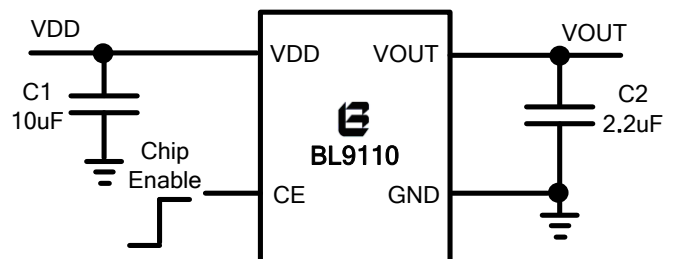



Absolute Maximum Rating (Note 1)

Input Supply Voltage (V_{DD})	-0.3V to +7V	Maximum Junction Temperature	125°C
CE Input Voltage	-0.3V to +7V	Operating Temperature Range <small>(Note2)</small>	-40°C to 85°C
Output Voltage	-0.3V to $V_{IN}+0.3V$	Storage Temperature Range	-65°C to 125°C
Output Current	1.4A	Lead Temperature (Soldering, 10s)	300°C

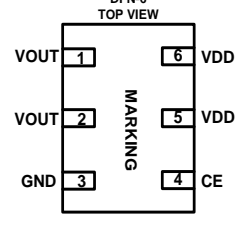
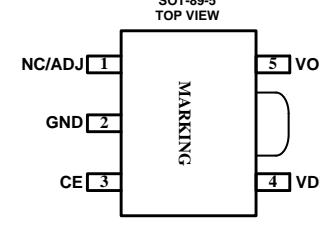
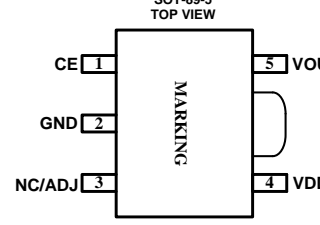
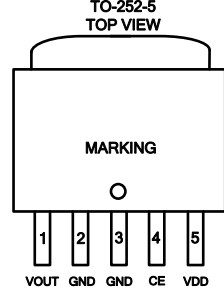
Package Information

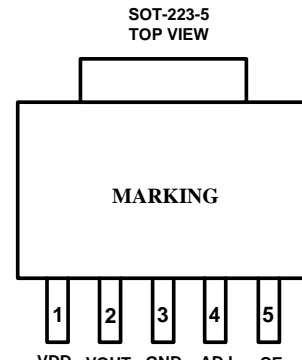
DFN-6 TOP VIEW	SOT-89-5 TOP VIEW	SOT-89-5 TOP VIEW	TO-252-5 TOP VIEW
 <p>VOUT 1 6 VDD VOUT 2 5 VDD GND 3 4 CE</p> <p>MARKING</p> <p>AA</p>	 <p>NC/ADJ 1 5 VOUT GND 2 4 VDD CE 3</p> <p>MARKING</p> <p>BA</p>	 <p>CE 1 5 VOUT GND 2 4 VDD NC/ADJ 3</p> <p>MARKING</p> <p>BB</p>	 <p>MARKING</p> <p>1 2 3 4 5 VOUT GND GND CE VDD</p> <p>CA</p>
Part Number	Top Mark	Temp Range	
BL9110-VVVXXAA	BL9110AA YWSS VVV <small>(Note3)</small>	-40°C to +85°C	
BL9110-VVVXXBA/B	BL9110BA/B YWSS VVV	-40°C to +85°C	
BL9110-VVVXXCA	BL9110CA YWSS VVV	-40°C to +85°C	

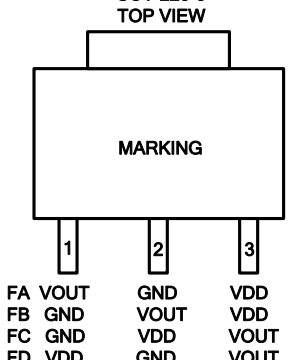
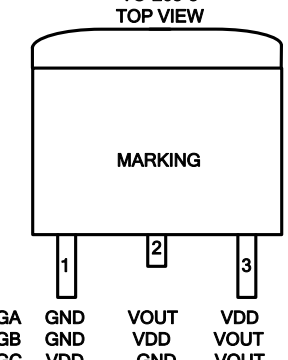
SOT-223-5 TOP VIEW	TO-252-3 TOP VIEW	SOT-223-3 TOP VIEW	TO-263-3 TOP VIEW
 <p>MARKING</p> <p>1 2 3 4 5 VDD VOUT GND ADJ CE</p>	 <p>MARKING</p> <p>1 2 3 EA GND VOUT VDD EB VDD GND VOUT</p>	 <p>MARKING</p> <p>1 2 3 FA VOUT GND VDD FB GND VDD VDD FC GND VOUT VOUT FD VDD GND VOUT</p>	 <p>MARKING</p> <p>1 2 3 GA GND VOUT VDD GB GND VDD VOUT GC VDD GND VOUT</p>
Part Number	Top Mark	Temp Range	
BL9110-VVVXXDA	BL9110DA	-40°C to +85°C	

	YWSS VVV	
BL9110-VVVXXEA/B	BL9110EA/B YWSS VVV	-40°C to +85°C
BL9110-VVVXXFA/B/C/D	BL9110FA/B/C/D YWSS VVV	-40°C to +85°C
BL9110-VVVXXGA/B/C	BL9110GA/B/C YWSS VVV	-40°C to +85°C

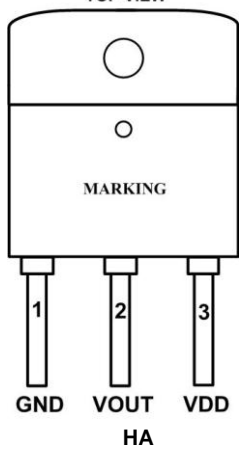
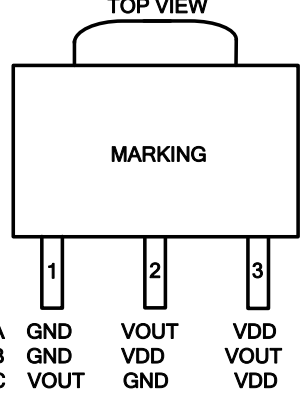
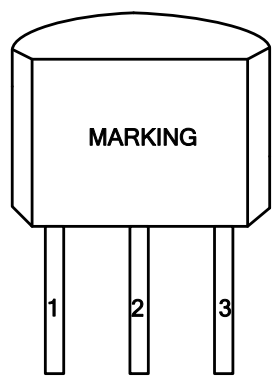
DA	 <p>TO-220-3 TOP VIEW</p> <p>MARKING</p> <p>1 2 3</p> <p>GND VOUT VDD</p> <p>HA</p>	 <p>SOT-89-3 TOP VIEW</p> <p>MARKING</p> <p>1 2 3</p> <p>IA GND VOUT VDD VOUT VDD IB GND VDD GND VDD VDD IC VOUT GND VDD VDD</p>	 <p>TO92 TOPVIEW</p> <p>MARKING</p> <p>1 2 3</p> <p>JA GND VOUT VDD</p>
	Part Number	Top Mark	Temp Range
BL9110-VVVXXHA	BL9110HA YWSS VVV	-40°C to +85°C	
BL9110-VVVXXI/A/B/C	BL9110IA/B/C YWSS VVV	-40°C to +85°C	
BL9110-VVVXXJA	BL9110JA YWSS VVV	-40°C to +85°C	

Pin Descriptions

Symbol	Description
VOUT	Output Pin
GND	Ground Pin
CE	Chip Enable Pin (High active)
VDD	Input Pin
ADJ/NC	Adjustable/No Connection

VVV	100	120	130	...	285	...	495	500	ADJ
Voltage (V)	1.0	1.2	1.3	...	2.85	...	4.95	5.0	Adjustable

Y	0	1	2	3	4	...
Year	2010	2011	2012	2013	2014

W	01	2	...	26	27	28	...	52
Week	A	B	...	Z	\bar{A}	\bar{B}	...	\bar{Z}

Thermal Resistance ^(Note 4):

Package	Θ_{JA}	Θ_{JC}
DFN-6	95°C/W	10°C/W
SOT-89-5	160°C/W	45°C/W
TO-252-5	90°C/W	10°C/W
SOT-223-5	160°C/W	20°C/W
TO-252-3	90°C/W	10°C/W
SOT-223-3	160°C/W	20°C/W
TO-263-3	65°C/W	7°C/W
TO-220-3	50°C/W	7°C/W
SOT89-3	180°C/W	50°C/W

Note 1: Absolute Maximum Ratings are those values beyond which the life of a device may be impaired.

Note 2: The BL9110 is guaranteed to meet performance specifications from 0°C to 70°C. Specifications over the -40°C to 85°C operating temperature range are assured by design, characterization and correlation with statistical process controls.

Note 3: Y: Year of assembly manufacturing

W: Week of assembly manufacturing

SS: Lot ID (the 7th and 8th number of Lot numbers)

VVV: Voltage code (for example 100 stands for 1.0V)

Note 4: Thermal Resistance is specified with approximately 1 square of 1 oz copper.

Block Diagram

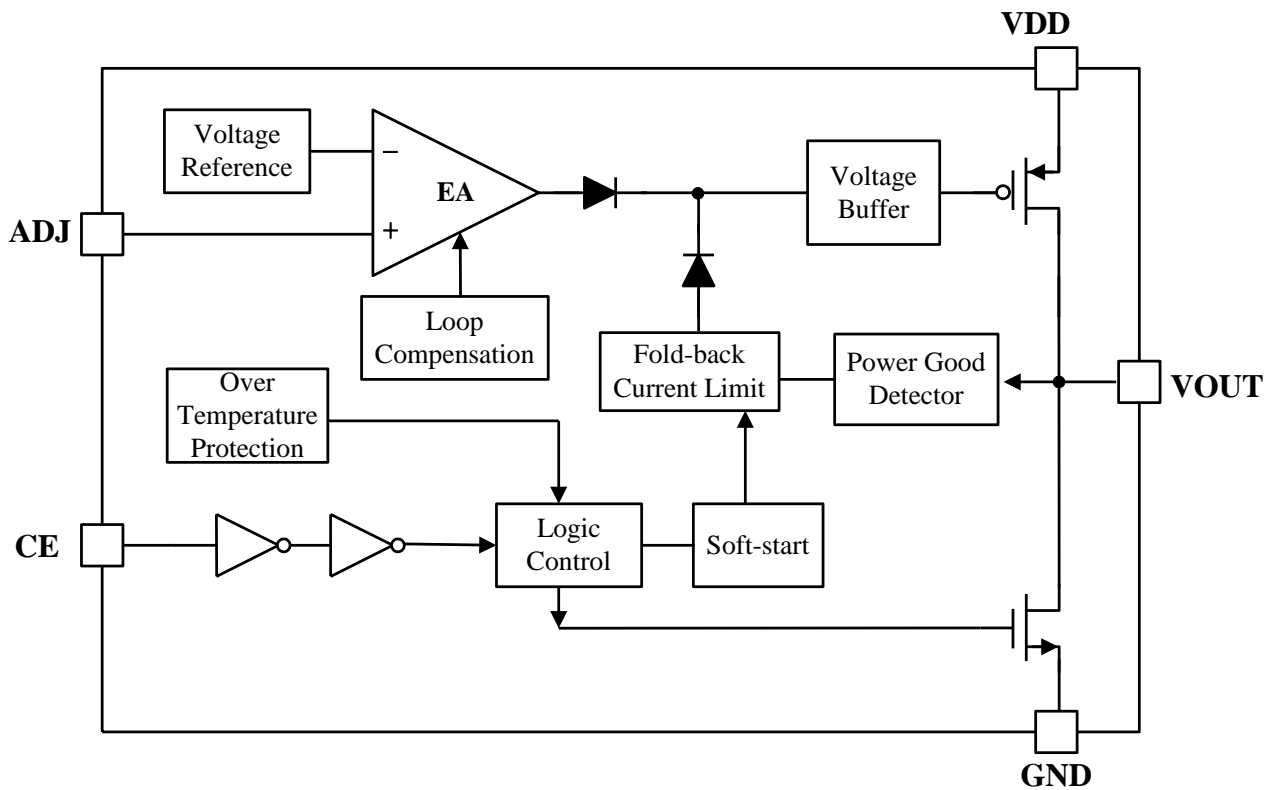

Electrical Characteristics (Note 5)

BL9110-1.2V Electrical Characteristics

($V_{DD}=2.5V$, $V_{OUT}=1.2V$, $C_E=V_{DD}$, $C_{IN}=2.2\mu F$, $C_{OUT}=2.2\mu F$, $T_A=25^\circ C$, unless otherwise noted.)

Parameter	Symbol	Conditions	MIN	TYP	MAX	unit
Input Voltage	V_{DD}		2.5		6	V
Output Voltage Accuracy (Note 6)	ΔV_{OUT}	$I_{OUT}=1mA$	-1		+1	%
			-2		+2	
Current Limit	I_{LIM}		1.0	1.3		A
Short Circuit Current	I_{SCC}	$V_{OUT}=0$		250		mA
Quiescent Current	I_Q	$I_{OUT}=0mA$		70	120	μA
Standby Current	I_{STBY}	$V_{CE}=GND$, Shutdown		0.01	1	μA
Dropout Voltage (note 7)	V_{DROP}	$I_{OUT}=300mA$		420	715	mV
		$I_{OUT}=1A$		870	1310	
Line Regulation (Note 8)	ΔV_{LINE}	$2.5V \leq V_{DD} \leq 6V$, $I_{OUT}=100mA$		0.05	0.5	%/V
Load Regulation (Note 9)	ΔV_{LOAD}	$1mA \leq I_{OUT} \leq 1A$		20		mV
Output Voltage Temperature Coefficient (Note 10)	TC_{VOUT}	$I_{OUT}=100mA$ $-40^\circ C \leq T \leq 85^\circ C$		± 100		ppm/ $^\circ C$
CE Input Threshold	Logic Low	V_{IL}			0.4	V
	Logic High	V_{IH}		1.0		V
CE Pull-down Resistance	R_{CE}			5		M Ω
Output Noise Voltage	e_{NO}	10Hz to 100KHz, $I_{OUT}=1mA$		45		μV_{RMS}
Power Supply Rejection Ratio	f=1kHz ($V_{OUT} \leq 3.3V$)	PSRR	0.2V _{P-P} Ripple $I_{OUT}=100mA$		70	dB
	f=1kHz ($V_{OUT} > 3.3V$)				60	
Thermal Shutdown Temperature	T_{SD}	Shutdown, Temp increasing		165		$^\circ C$
Thermal Shutdown Hysteresis	T_{SDHY}			30		$^\circ C$
Output Discharge Resistance	R_{DSC}			50		Ω

Note 5: 100% production test at $+25^\circ C$. Specifications over the temperature range are guaranteed by design and characterization.

Note 6: This IC includes two kinds of output voltage accuracy versions. A: $\pm 1\%$, B: $\pm 2\%$.

Note 7: The required minimum input operating voltage is equal to $V_{OUT} + V_{DROP}$, and if $V_{OUT} + V_{DROP} < 2.5V$, the required minimum input operating voltage must be set to 2.5V. V_{OUT} is the normal output voltage, e.g. $V_{OUT}=2.8V$ for 2.8V fixed output version.

Note 8: Line regulation is calculated by
$$\Delta V_{LINE} = \left(\frac{V_{OUT1} - V_{OUT2}}{\Delta V_{DD} \times V_{OUT}} \right) \times 100$$

Where V_{OUT1} is the output voltage when $V_{DD1}=6.0V$, V_{OUT2} is the output voltage when $V_{DD2} = \max(V_{OUT} + 0.5V, 2.5V)$.
 $\Delta V_{DD} = V_{DD1} - V_{DD2}$.

Note 9: Load regulation is calculated by
$$\Delta V_{LOAD} = V_{OUT1} - V_{OUT2}$$

Where V_{OUT1} is the output voltage when $I_{OUT1}=1mA$, and V_{OUT2} is the output voltage when $I_{OUT2}=1A$.

Note 10: The temperature coefficient is calculated by
$$TC_{VOUT} = \frac{\Delta V_{OUT}}{\Delta T \times V_{OUT}}$$

BL9110-1.5V Electrical Characteristics

($V_{DD}=2.5V$, $V_{OUT}=1.5V$, $CE=V_{DD}$, $C_{IN}=2.2\mu F$, $C_{OUT}=2.2\mu F$, $T_A=25^\circ C$, unless otherwise noted.)

Parameter	Symbol	Conditions	MIN	TYP	MAX	unit
Input Voltage	V_{DD}		2.5		6	V
Output Voltage Accuracy (Note 6)	ΔV_{OUT}	$I_{OUT}=1mA$	-1		+1	%
			-2		+2	
Current Limit	I_{LIM}		1.0	1.3		A
Short Circuit Current	I_{SCC}	$V_{OUT}=0$		250		mA
Quiescent Current	I_Q	$I_{OUT}=0mA$		70	120	μA
Standby Current	I_{STBY}	$V_{CE}=GND$, Shutdown		0.01	1	μA
Dropout Voltage (note 7)	V_{DROP}	$I_{OUT}=300mA$		260	445	mV
		$I_{OUT}=1A$		700	1050	
Line Regulation (Note 8)	ΔV_{LINE}	$2.5V \leq V_{DD} \leq 6V$, $I_{OUT}=100mA$		0.05	0.5	%/V
Load Regulation (Note 9)	ΔV_{LOAD}	$1mA \leq I_{OUT} \leq 1A$		20		mV
Output Voltage Temperature Coefficient (Note 10)	TC_{VOUT}	$I_{OUT}=100mA$ $-40^\circ C \leq T \leq 85^\circ C$		± 100		ppm/ $^\circ C$
Input Threshold	CE Logic Low	V_{IL}			0.4	V
	CE Logic High	V_{IH}		1.0		V
CE Pull-down Resistance	R_{CE}			5		$M\Omega$
Output Noise Voltage	e_{NO}	10Hz to 100KHz, $I_{OUT}=1mA$		45		μV_{RMS}
Power Supply Rejection Ratio	f=1kHz ($V_{OUT} \leq 3.3V$)	PSRR	0.2V _{P-P} Ripple $I_{OUT}=100mA$		70	dB
	f=1kHz ($V_{OUT} > 3.3V$)				60	
Thermal Shutdown Temperature	T_{SD}	Shutdown, Temp increasing		165		$^\circ C$
Thermal Shutdown Hysteresis	T_{SDHY}			30		$^\circ C$
Output Discharge Resistance	R_{DSC}			50		Ω

Note 5: 100% production test at +25 $^\circ C$. Specifications over the temperature range are guaranteed by design and characterization.

Note 6: This IC includes two kinds of output voltage accuracy versions. A: $\pm 1\%$, B: $\pm 2\%$.

Note 7: The required minimum input operating voltage is equal to $V_{OUT}+V_{DROP}$, and if $V_{OUT}+V_{DROP} < 2.5V$, the required minimum input operating voltage must be set to 2.5V. V_{OUT} is the normal output voltage, e.g. $V_{OUT}=2.8V$ for 2.8V fixed output version.

Note 8: Line regulation is calculated by
$$\Delta V_{LINE} = \left(\frac{V_{OUT1} - V_{OUT2}}{\Delta V_{DD} \times V_{OUT}} \right) \times 100$$

Where V_{OUT1} is the output voltage when $V_{DD1}=6.0V$, V_{OUT2} is the output voltage when $V_{DD2} = \max(V_{OUT}+0.5V, 2.5V)$. $\Delta V_{DD}=V_{DD1}-V_{DD2}$.

Note 9: Load regulation is calculated by
$$\Delta V_{LOAD} = V_{OUT1} - V_{OUT2}$$

Where V_{OUT1} is the output voltage when $I_{OUT1}=1mA$, and V_{OUT2} is the output voltage when $I_{OUT2}=1.0A$.

Note 10: The temperature coefficient is calculated by
$$TC_{VOUT} = \frac{\Delta V_{OUT}}{\Delta T \times V_{OUT}}$$

BL9110-1.8V Electrical Characteristics

($V_{DD}=2.8V$, $V_{OUT}=1.8V$, $CE=V_{DD}$, $C_{IN}=2.2\mu F$, $C_{OUT}=2.2\mu F$, $T_A=25^\circ C$, unless otherwise noted.)

Parameter	Symbol	Conditions	MIN	TYP	MAX	unit
Input Voltage	V_{DD}		2.5		6	V
Output Voltage Accuracy (Note 6)	ΔV_{OUT}	$I_{OUT}=1mA$	-1		+1	%
			-2		+2	
Current Limit	I_{LIM}		1.0	1.3		A
Short Circuit Current	I_{SCC}	$V_{OUT}=0$		250		mA
Quiescent Current	I_Q	$I_{OUT}=0mA$		70	120	μA
Standby Current	I_{STBY}	$V_{CE}=GND$, Shutdown		0.01	1	μA
Dropout Voltage (note 7)	V_{DROP}	$I_{OUT}=300mA$		180	308	mV
		$I_{OUT}=1A$		570	855	
Line Regulation (Note 8)	ΔV_{LINE}	$2.5V \leq V_{DD} \leq 6V$, $I_{OUT}=100mA$		0.05	0.5	%/V
Load Regulation (Note 9)	ΔV_{LOAD}	$1mA \leq I_{OUT} \leq 1A$		20		mV
Output Voltage Temperature Coefficient (Note 10)	TC_{VOUT}	$I_{OUT}=100mA$ $-40^\circ C \leq T \leq 85^\circ C$		± 100		ppm/ $^\circ C$
Input Threshold	CE Logic Low	V_{IL}			0.4	V
	CE Logic High	V_{IH}		1.0		V
CE Pull-down Resistance	R_{CE}			5		$M\Omega$
Output Noise Voltage	e_{NO}	10Hz to 100KHz, $I_{OUT}=1mA$		45		μV_{RMS}
Power Supply Rejection Ratio	f=1kHz ($V_{OUT} \leq 3.3V$)	PSRR	0.2V _{P-P} Ripple $I_{OUT}=100mA$		70	dB
	f=1kHz ($V_{OUT} > 3.3V$)				60	
Thermal Shutdown Temperature	T_{SD}	Shutdown, Temp increasing		165		$^\circ C$
Thermal Shutdown Hysteresis	T_{SDHY}			30		$^\circ C$
Output Discharge Resistance	R_{DSC}			50		Ω

Note 5: 100% production test at +25 $^\circ C$. Specifications over the temperature range are guaranteed by design and characterization.

Note 6: This IC includes two kinds of output voltage accuracy versions. A: $\pm 1\%$, B: $\pm 2\%$.

Note 7: The required minimum input operating voltage is equal to $V_{OUT}+V_{DROP}$, and if $V_{OUT}+V_{DROP} < 2.5V$, the required minimum input operating voltage must be set to 2.5V. V_{OUT} is the normal output voltage, e.g. $V_{OUT}=2.8V$ for 2.8V fixed output version.

Note 8: Line regulation is calculated by
$$\Delta V_{LINE} = \left(\frac{V_{OUT1} - V_{OUT2}}{\Delta V_{DD} \times V_{OUT}} \right) \times 100$$

Where V_{OUT1} is the output voltage when $V_{DD1}=6.0V$, V_{OUT2} is the output voltage when $V_{DD2} = \max(V_{OUT}+0.5V, 2.5V)$.
 $\Delta V_{DD} = V_{DD1} - V_{DD2}$.

Note 9: Load regulation is calculated by
$$\Delta V_{LOAD} = V_{OUT1} - V_{OUT2}$$

Where V_{OUT1} is the output voltage when $I_{OUT1}=1mA$, and V_{OUT2} is the output voltage when $I_{OUT2}=1.0A$.

Note 10: The temperature coefficient is calculated by
$$TC_{VOUT} = \frac{\Delta V_{OUT}}{\Delta T \times V_{OUT}}$$

BL9110-2.5V Electrical Characteristics

($V_{DD}=3.5V$, $V_{OUT}=2.5V$, $C_E=V_{DD}$, $C_{IN}=2.2\mu F$, $C_{OUT}=2.2\mu F$, $T_A=25^\circ C$, unless otherwise noted.)

Parameter	Symbol	Conditions	MIN	TYP	MAX	unit
Input Voltage	V_{DD}		2.5		6	V
Output Voltage Accuracy (Note 6)	ΔV_{OUT}	$I_{OUT}=1mA$	-1		+1	%
			-2		+2	
Current Limit	I_{LIM}		1.0	1.3		A
Short Circuit Current	I_{SCC}	$V_{OUT}=0$		250		mA
Quiescent Current	I_Q	$I_{OUT}=0mA$		70	120	μA
Standby Current	I_{STBY}	$V_{CE}=GND$, Shutdown		0.01	1	μA
Dropout Voltage (note 7)	V_{DROP}	$I_{OUT}=300mA$		140	240	mV
		$I_{OUT}=1A$		440	660	
Line Regulation (Note 8)	ΔV_{LINE}	$3.0V \leq V_{DD} \leq 6V$, $I_{OUT}=100mA$		0.05	0.5	%/V
Load Regulation (Note 9)	ΔV_{LOAD}	$1mA \leq I_{OUT} \leq 1A$		20		mV
Output Voltage Temperature Coefficient (Note 10)	TC_{VOUT}	$I_{OUT}=100mA$ $-40^\circ C \leq T \leq 85^\circ C$		± 100		ppm/ $^\circ C$
Input Threshold	CE Logic Low	V_{IL}			0.4	V
	CE Logic High	V_{IH}		1.0		V
CE Pull-down Resistance	R_{CE}			5		$M\Omega$
Output Noise Voltage	e_{NO}	10Hz to 100KHz, $I_{OUT}=1mA$		45		μV_{RMS}
Power Supply Rejection Ratio	f=1kHz ($V_{OUT} \leq 3.3V$)	PSRR	0.2V _{P-P} Ripple $I_{OUT}=100mA$		70	dB
	f=1kHz ($V_{OUT} > 3.3V$)				60	
Thermal Shutdown Temperature	T_{SD}	Shutdown, Temp increasing		165		$^\circ C$
Thermal Shutdown Hysteresis	T_{SDHY}			30		$^\circ C$
Output Discharge Resistance	R_{DSC}			50		Ω

Note 5: 100% production test at +25 $^\circ C$. Specifications over the temperature range are guaranteed by design and characterization.

Note 6: This IC includes two kinds of output voltage accuracy versions. A: $\pm 1\%$, B: $\pm 2\%$.

Note 7: The required minimum input operating voltage is equal to $V_{OUT}+V_{DROP}$, and if $V_{OUT}+V_{DROP} < 2.5V$, the required minimum input operating voltage must be set to 2.5V. V_{OUT} is the normal output voltage, e.g. $V_{OUT}=2.8V$ for 2.8V fixed output version.

Note 8: Line regulation is calculated by
$$\Delta V_{LINE} = \left(\frac{V_{OUT1} - V_{OUT2}}{\Delta V_{DD} \times V_{OUT}} \right) \times 100$$

Where V_{OUT1} is the output voltage when $V_{DD1}=6.0V$, V_{OUT2} is the output voltage when $V_{DD2} = \max(V_{OUT}+0.5V, 2.5V)$.
 $\Delta V_{DD} = V_{DD1} - V_{DD2}$.

Note 9: Load regulation is calculated by
$$\Delta V_{LOAD} = V_{OUT1} - V_{OUT2}$$

Where V_{OUT1} is the output voltage when $I_{OUT1}=1mA$, and V_{OUT2} is the output voltage when $I_{OUT2}=1.0A$.

Note 10: The temperature coefficient is calculated by
$$TC_{VOUT} = \frac{\Delta V_{OUT}}{\Delta T \times V_{OUT}}$$

BL9110-3.3V Electrical Characteristics

($V_{DD}=4.3V$, $V_{OUT}=3.3V$, $C_E=V_{DD}$, $C_{IN}=2.2\mu F$, $C_{OUT}=2.2\mu F$, $T_A=25^\circ C$, unless otherwise noted.)

Parameter	Symbol	Conditions	MIN	TYP	MAX	unit
Input Voltage	V_{DD}		2.5		6	V
Output Voltage Accuracy (Note 6)	ΔV_{OUT}	$I_{OUT}=1mA$	-1		+1	%
			-2		+2	
Current Limit	I_{LIM}		1.0	1.3		A
Short Circuit Current	I_{SCC}	$V_{OUT}=0$		250		mA
Quiescent Current	I_Q	$I_{OUT}=0mA$		70	120	μA
Standby Current	I_{STBY}	$V_{CE}=GND$, Shutdown		0.01	1	μA
Dropout Voltage (note 7)	V_{DROP}	$I_{OUT}=300mA$		110	188	mV
		$I_{OUT}=1A$		350	525	
Line Regulation (Note 8)	ΔV_{LINE}	$3.8V \leq V_{DD} \leq 6V$, $I_{OUT}=100mA$		0.05	0.5	%/V
Load Regulation (Note 9)	ΔV_{LOAD}	$1mA \leq I_{OUT} \leq 1A$		20		mV
Output Voltage Temperature Coefficient (Note 10)	TC_{VOUT}	$I_{OUT}=100mA$ $-40^\circ C \leq T \leq 85^\circ C$		± 100		ppm/ $^\circ C$
Input Threshold	CE Logic Low	V_{IL}			0.4	V
	CE Logic High	V_{IH}		1.0		V
CE Pull-down Resistance	R_{CE}			5		$M\Omega$
Output Noise Voltage	e_{NO}	10Hz to 100KHz, $I_{OUT}=1mA$		45		μV_{RMS}
Power Supply Rejection Ratio	f=1kHz ($V_{OUT} \leq 3.3V$)	PSRR	0.2V _{P-P} Ripple $I_{OUT}=100mA$		70	dB
	f=1kHz ($V_{OUT} > 3.3V$)				60	
Thermal Shutdown Temperature	T_{SD}	Shutdown, Temp increasing		165		$^\circ C$
Thermal Shutdown Hysteresis	T_{SDHY}			30		$^\circ C$
Output Discharge Resistance	R_{DSC}			50		Ω

Note 5: 100% production test at +25 $^\circ C$. Specifications over the temperature range are guaranteed by design and characterization.

Note 6: This IC includes two kinds of output voltage accuracy versions. A: $\pm 1\%$, B: $\pm 2\%$.

Note 7: The required minimum input operating voltage is equal to $V_{OUT}+V_{DROP}$, and if $V_{OUT}+V_{DROP} < 2.5V$, the required minimum input operating voltage must be set to 2.5V. V_{OUT} is the normal output voltage, e.g. $V_{OUT}=2.8V$ for 2.8V fixed output version.

Note 8: Line regulation is calculated by
$$\Delta V_{LINE} = \left(\frac{V_{OUT1} - V_{OUT2}}{\Delta V_{DD} \times V_{OUT}} \right) \times 100$$

Where V_{OUT1} is the output voltage when $V_{DD1}=6.0V$, V_{OUT2} is the output voltage when $V_{DD2} = \max(V_{OUT}+0.5V, 2.5V)$.
 $\Delta V_{DD} = V_{DD1} - V_{DD2}$.

Note 9: Load regulation is calculated by
$$\Delta V_{LOAD} = V_{OUT1} - V_{OUT2}$$

Where V_{OUT1} is the output voltage when $I_{OUT1}=1mA$, and V_{OUT2} is the output voltage when $I_{OUT2}=1.0A$.

Note 10: The temperature coefficient is calculated by
$$TC_{VOUT} = \frac{\Delta V_{OUT}}{\Delta T \times V_{OUT}}$$
.

BL9110-5.0V Electrical Characteristics

($V_{DD}=6.0V$, $V_{OUT}=5.0V$, $CE=V_{DD}$, $C_{IN}=2.2\mu F$, $C_{OUT}=2.2\mu F$, $T_A=25^\circ C$, unless otherwise noted.)

Parameter	Symbol	Conditions	MIN	TYP	MAX	unit
Input Voltage	V_{DD}		2.5		6	V
Output Voltage Accuracy (Note 6)	ΔV_{OUT}	$I_{OUT}=1mA$	-1		+1	%
			-2		+2	
Current Limit	I_{LIM}		1.0	1.3		A
Short Circuit Current	I_{SCC}	$V_{OUT}=0$		250		mA
Quiescent Current	I_Q	$I_{OUT}=0mA$		70	120	μA
Standby Current	I_{STBY}	$V_{CE}=GND$, Shutdown		0.01	1	μA
Dropout Voltage (note 7)	V_{DROP}	$I_{OUT}=300mA$		100	170	mV
		$I_{OUT}=1A$		340	510	
Line Regulation (Note 8)	ΔV_{LINE}	$5.5V \leq V_{DD} \leq 6V$, $I_{OUT}=100mA$		0.05	0.5	%/V
Load Regulation (Note 9)	ΔV_{LOAD}	$1mA \leq I_{OUT} \leq 1A$		20		mV
Output Voltage Temperature Coefficient (Note 10)	TC_{VOUT}	$I_{OUT}=100mA$ $-40^\circ C \leq T \leq 85^\circ C$		± 100		ppm/ $^\circ C$
Input Threshold	CE Logic Low	V_{IL}			0.4	V
	CE Logic High	V_{IH}		1.0		V
CE Pull-down Resistance	R_{CE}			5		$M\Omega$
Output Noise Voltage	e_{NO}	10Hz to 100KHz, $I_{OUT}=1mA$		45		μV_{RMS}
Power Supply Rejection Ratio	f=1kHz ($V_{OUT} \leq 3.3V$)	PSRR	0.2V _{P-P} Ripple $I_{OUT}=100mA$		70	dB
	f=1kHz ($V_{OUT} > 3.3V$)				60	
Thermal Shutdown Temperature	T_{SD}	Shutdown, Temp increasing		165		$^\circ C$
Thermal Shutdown Hysteresis	T_{SDHY}			30		$^\circ C$
Output Discharge Resistance	R_{DSC}			50		Ω

Note 5: 100% production test at +25 $^\circ C$. Specifications over the temperature range are guaranteed by design and characterization.

Note 6: This IC includes two kinds of output voltage accuracy versions. A: $\pm 1\%$, B: $\pm 2\%$.

Note 7: The required minimum input operating voltage is equal to $V_{OUT}+V_{DROP}$, and if $V_{OUT}+V_{DROP} < 2.5V$, the required minimum input operating voltage must be set to 2.5V. V_{OUT} is the normal output voltage, e.g. $V_{OUT}=2.8V$ for 2.8V fixed output version.

Note 8: Line regulation is calculated by
$$\Delta V_{LINE} = \left(\frac{V_{OUT1} - V_{OUT2}}{\Delta V_{DD} \times V_{OUT}} \right) \times 100$$

Where V_{OUT1} is the output voltage when $V_{DD1}=6.0V$, V_{OUT2} is the output voltage when $V_{DD2} = \max(V_{OUT}+0.5V, 2.5V)$.
 $\Delta V_{DD} = V_{DD1} - V_{DD2}$.

Note 9: Load regulation is calculated by
$$\Delta V_{LOAD} = V_{OUT1} - V_{OUT2}$$

Where V_{OUT1} is the output voltage when $I_{OUT1}=1mA$, and V_{OUT2} is the output voltage when $I_{OUT2}=1.0A$.

Note 10: The temperature coefficient is calculated by
$$TC_{VOUT} = \frac{\Delta V_{OUT}}{\Delta T \times V_{OUT}}$$
.

Typical Performance Characteristic

($V_{DD}=V_{OUT}+1V$, and if $V_{OUT}<1.5V$, $V_{DD}=2.5V$ $C_E=V_{DD}$, $C_{IN}=2.2\mu F$, $C_{OUT}=2.2\mu F$, $T_A=25^\circ C$, unless otherwise noted.)

Output Voltage VS. Input Voltage
BL9110-1.0V

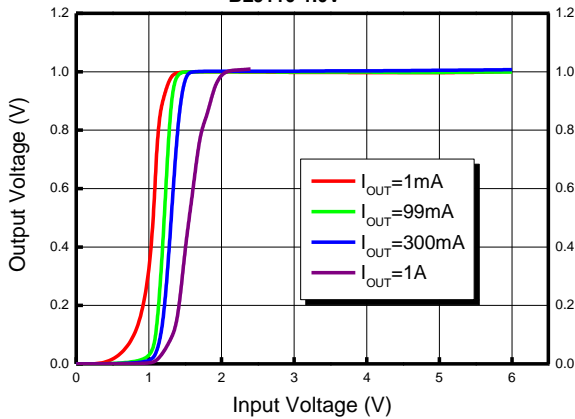

Dropout Voltage VS. Output Current
BL9110-3.3V

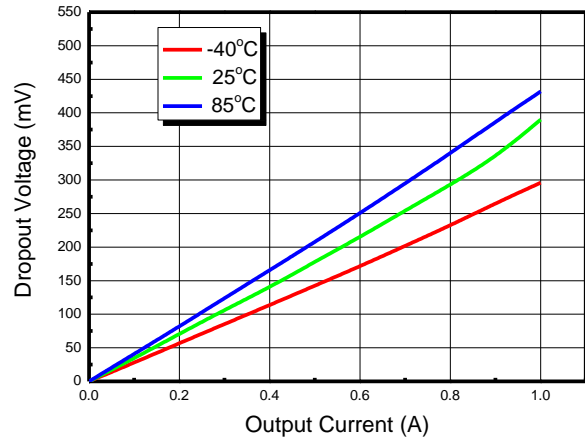

Output Voltage VS. Input Voltage
BL9110-3.3V

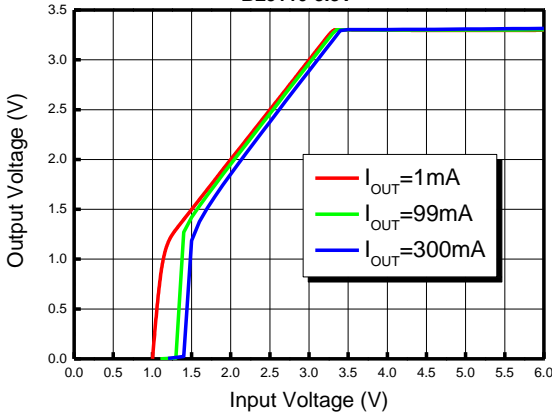

Output Voltage VS. Temperature
BL9110-3.3V

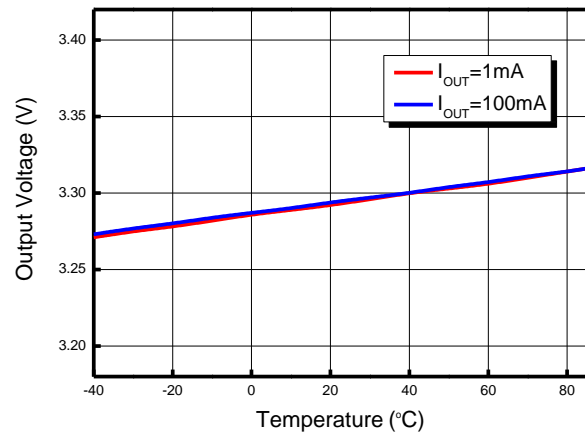

Quiescent Current VS. Temperature
BL9110-3.3V

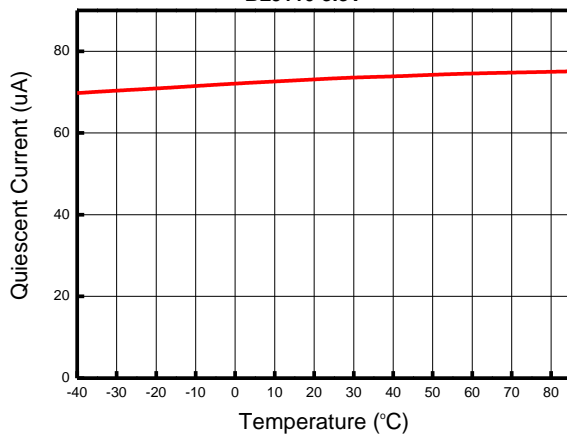

Quiescent Current VS. Input Voltage
BL9110-3.3V

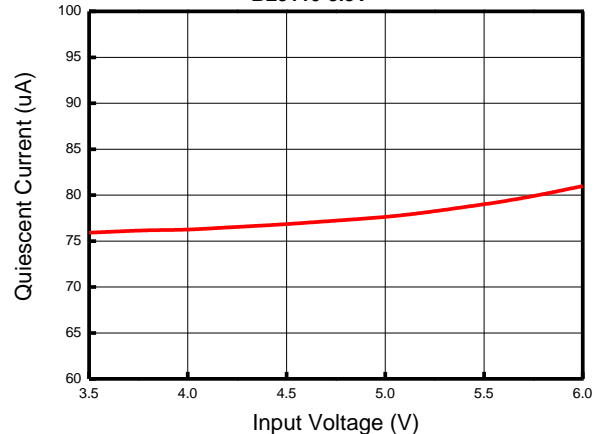

Output Voltage VS. Output Current
BL9110-3.3V

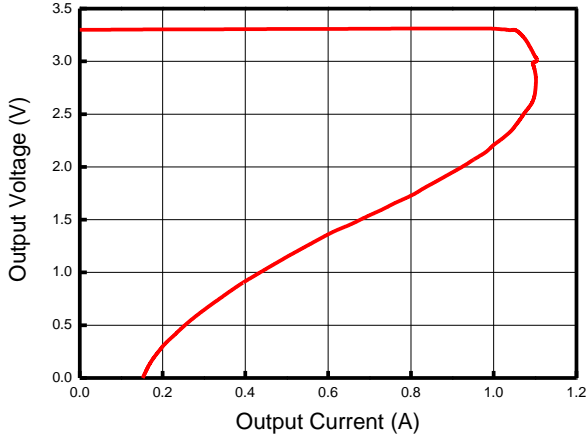

Turn on Transient Response
BL9110-3.3V

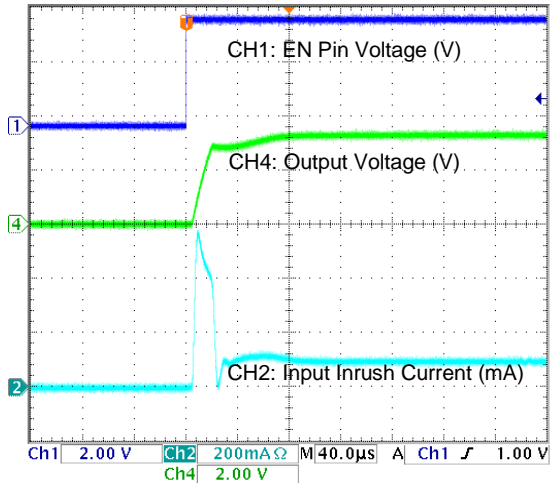

Turn off Transient Response
BL9110-3.3V

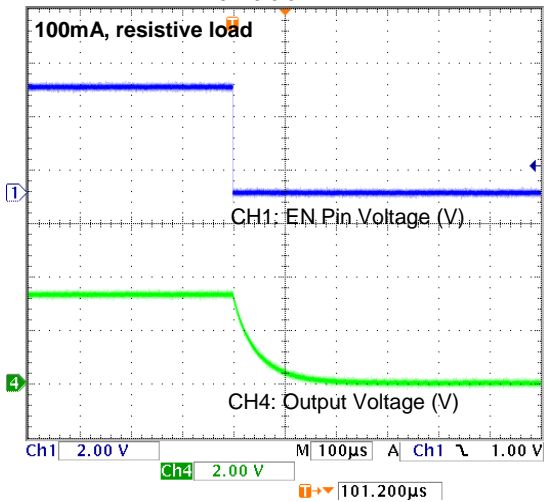

Turn off Transient Response
BL9110-3.3V

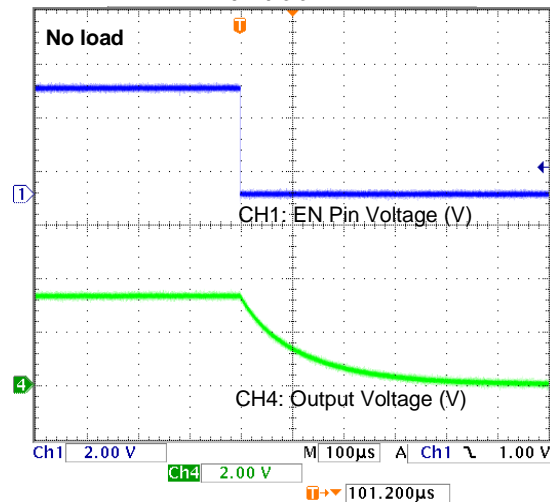

Load Transient Response
BL9110-3.3V

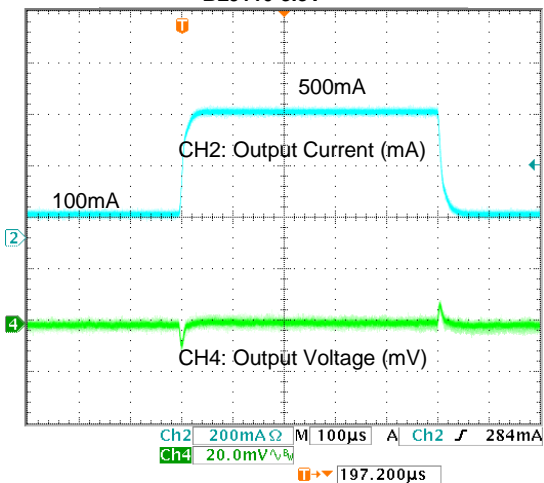

Load Transient Response
BL9110-3.3V

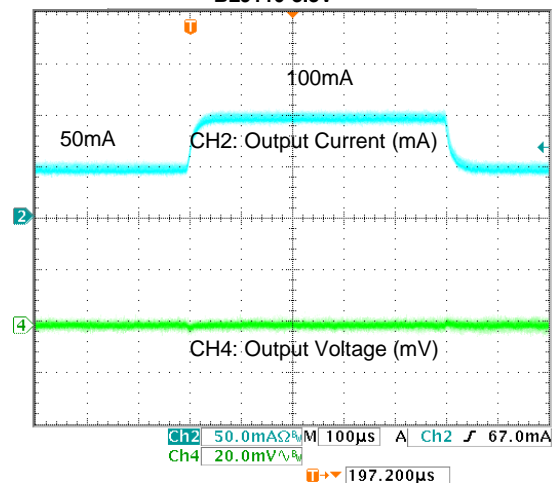

Line Transient Response

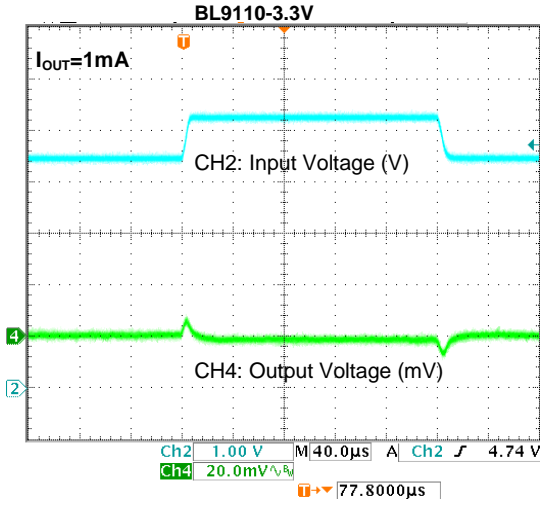

Line Transient Response

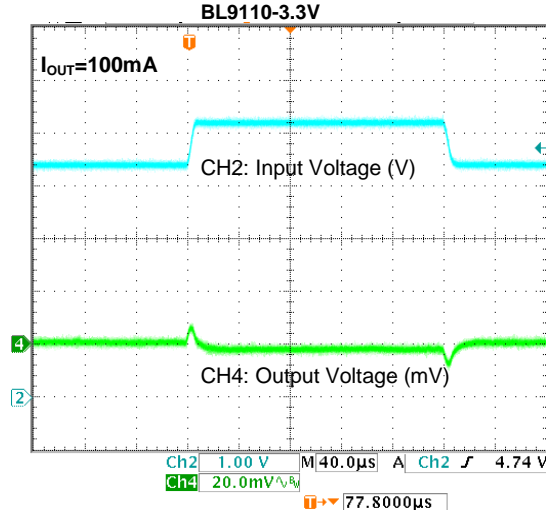

Applications Information

The BL9110 is a low dropout CMOS-based positive voltage regulator that operates the input voltage from +2.5V to 6.0V. Output voltages are optional ranging from 1.0V to 5.0V, and can supply current up to 1.0 A.

Enable Function

The BL9110 is shutdown by pulling the CE input low, and turn on by driving the input high. If this feature is not be used, the CE input should be floating or tied to VDD to keep the regulator on at all times.

Programming the BL9110 Adjustable LDO regulator

The BL9110 is available in two types, either fixed or adjustable output voltage. The output range of the adjustable types is from 1V to 5V. The output voltage of the BL9110 adjustable regulator is programmed using an external resistor divider as show in Figure as below. The output voltage is calculated using equation as below:

$$V_{OUT} = V_{REF} \times \left(1 + \frac{R1}{R2} \right)$$

Where $V_{REF}=1V$ is the internal reference voltage.

Resistors R1 and R2 should be chosen for approximately 50uA divider current. Lower value resistors can be used for improved noise performance, but the solution consumes more power. Higher resistor values should be avoided as leakage current at ADJ increases the output voltage error. The recommended design procedure

is to choose $R2=20k\Omega$ to set the divider current at 50uA, and then calculate R1 using Equation as below:

$$R1 = \left(\frac{V_{OUT}}{V_{REF}} - 1 \right) \times R2$$

A small compensation capacitor C3 placed between VOUT and ADJ may improve the stability of the adjustable. The suggested value of this capacitor is about 10pF to 22pF.

OUTPUT VOLTAGE PROGRAMMING GUIDE

OUTPUT VOLTAGE	R1	R2
1.8V	16 kΩ	20 kΩ
2.5V	30 kΩ	20 kΩ
3.3V	51 kΩ	22 kΩ
3.6V	62 kΩ	24 kΩ

BL9110 Adjustable LDO regulator Programming

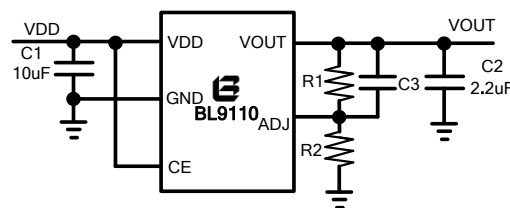

Thermal Protection

Thermal overload protection limits total power dissipation in the BL9110. When the junction temperature exceeds $T_j=165^\circ C$, the OTP circuit starts the thermal shutdown function and turns the pass element off allowing the IC to cool. The OTP circuit turns on the pass element again after IC's junction temperature cool by $30^\circ C$, result in a pulsed output during continuous thermal

overload conditions. Thermal-overloaded protection is designed to protect the BL9110 in the event of fault conditions. Do not exceed the absolute maximum junction temperature rating of $T_J=125^{\circ}\text{C}$ for continuous operation. The build-in fold-back current limit protection circuit will reduce current value as output voltage drops. When output is shorted to ground, current limit is reduced to 250mA, avoiding damaging the device.

Operating Region and Power Dissipation

The maximum power dissipation of BL9110 depends on the thermal resistance of the case and circuit board, the temperature difference between the die junction and ambient air, and the rate of airflow. The power dissipation across the device is

$$P_D = (V_{DD} - V_{OUT}) \times I_{OUT} + V_{DD} \times I_Q$$

The maximum power dissipation is:

$$P_D(\text{MAX}) = (T_J(\text{MAX}) - T_A) / \theta_{JA}$$

Where $T_J(\text{MAX})$ is the maximum operation junction temperature 125°C , T_A is the ambient temperature and the θ_{JA} is the junction to ambient thermal resistance. The GND pin of the BL9110 performs the dual function of providing an electrical connection to ground and channeling heat away. Connect the GND pin to ground using a large pad or ground plane.

Capacitor Selection and Regulator Stability

Like any low-dropout regulator, the external

capacitors used with the BL9110 must be carefully selected for regulator stability and performance. The BL9110 requires an output capacitor between the VOUT and GND pins for phase compensation. Using a capacitor whose value is $\geq 1\mu\text{F}$ on the BL9110 input and the amount of capacitance can be increased without limit. The input capacitor must be located a distance of not more than 0.5 inch from the input pin of the IC and returned to a clean analog ground. Any good quality ceramic or tantalum can be used for this capacitor. The capacitor with larger value and lower ESR (equivalent series resistance) provides better PSRR and line-transient response. The output capacitor must meet both requirements for minimum amount of capacitance and ESR in all LDO applications. The BL9110 is designed specifically to work with low ESR ceramic output capacitor in space-saving and performance consideration. In the BL9110, phase compensation is made with the output capacitor for securing stable operation even if the load current is varied. For this purpose, use a 2.2uF capacitor between VOUT pin and GND pin as close as possible.

Load-Transient Considerations

The BL9110 load-transient response graphs show two components of the output response: a DC shift from the output impedance due to the load current change, and the transient response. The DC shift is quite small due to the excellent load regulation of the IC. Typical output voltage transient spike for a step change in the load current from 0mA to 50mA is tens of mV,

depending on the ESR of the output capacitor. Increasing the output capacitor's value and decreasing the ESR attenuates the overshoot.

Input-Output (Dropout) Voltage

A regulator's minimum input-output voltage differential (or dropout voltage) determines the lowest usable supply voltage. In battery-powered systems, this will determine the useful end-of-life battery voltage. Because the BL9110 uses a P-Channel MOSFET pass transistor, the dropout voltage is a function of drain-to-source on resistance $[R_{DS(ON)}]$ multiplied by the load current.

BL9110 SOT89-5 PCB Layout for Reference

Layout Considerations

To improve AC performance such as PSRR, output noise, and transient response, it is recommended that the PCB be designed with separate ground planes for VDD and VOUT, with each ground plane connected only at the GND pin of the device. Make VDD and GND lines sufficiently wide. If their impedance is high, noise pickup or unstable operation may result. Connect a capacitor C1 between VDD and GND pin, as close as possible to the pins. Set external components, especially the output capacitor C2, as close as possible to the IC, and make wiring as short as possible.

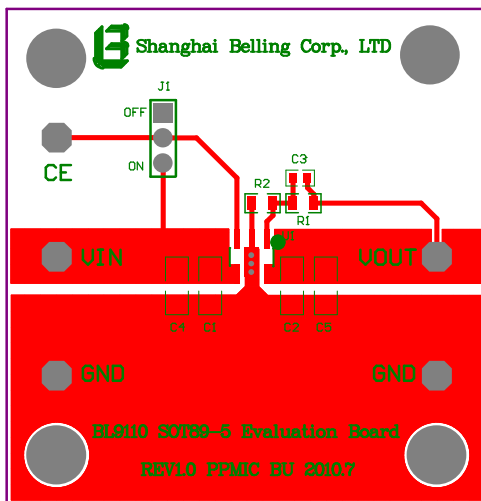

Top Layer

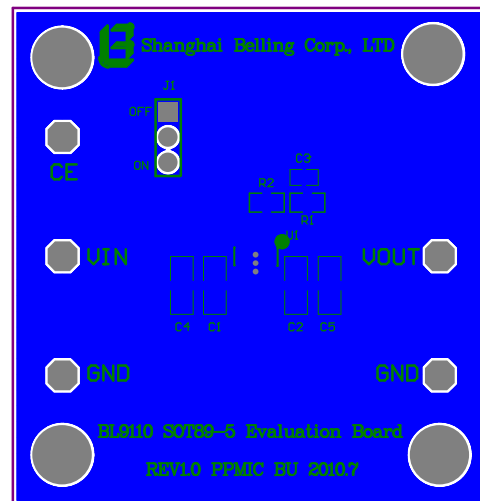

Bottom Layer

Package Description

DFN-6

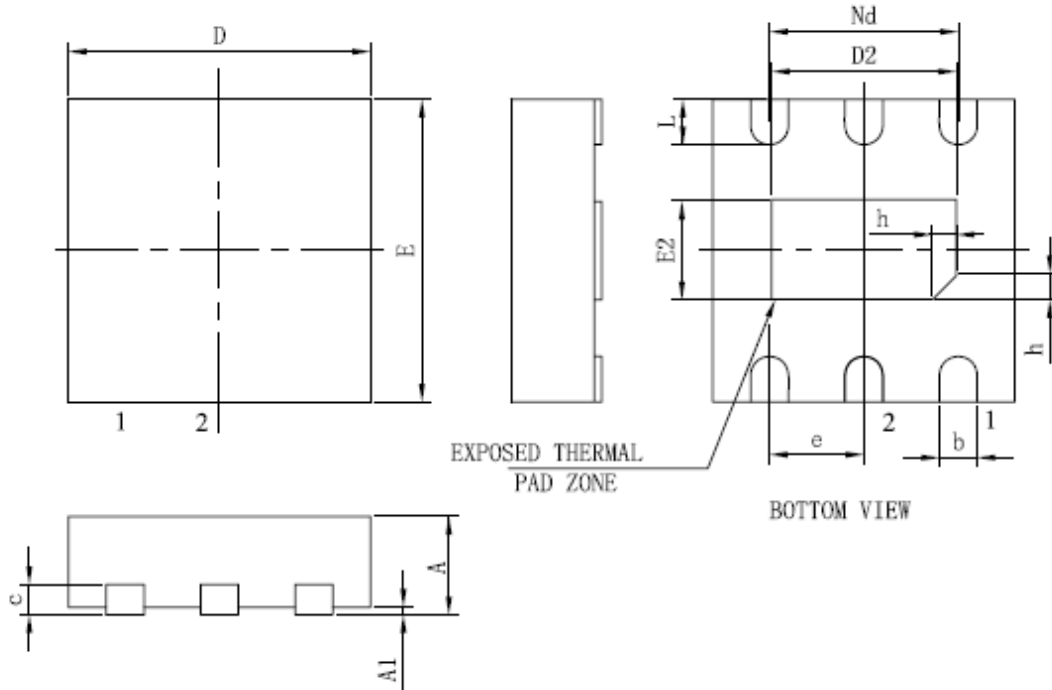

Symbol	Dimensions In Millimeters		
	Min	NOM	Max
A	0.7	0.75	0.8
A1		0.02	0.05
b	0.25	0.3	0.35
c	0.18	0.2	0.25
D	1.95	2	2.05
D2	1		1.45
e	0.65BSC		
Nd	1.30BSC		
E	1.95	2	2.05
E2	0.50		0.85
L	0.25	0.30	0.40
h	0.1	0.15	0.2

DFN-6 Surface Mount Package

SOT89-5

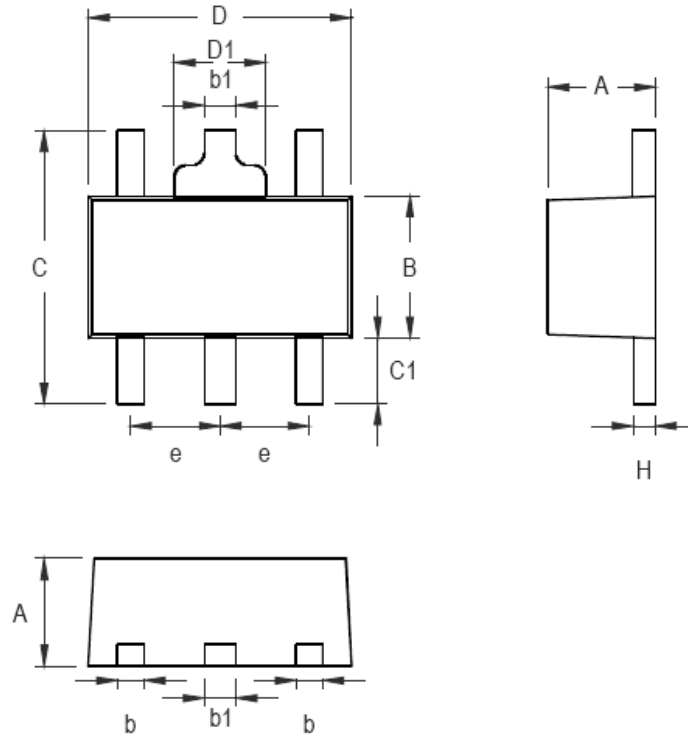

Symbol	Dimensions In Millimeters		Dimensions In Inches	
	Min	Max	Min	Max
A	1.397	1.600	0.055	0.063
b	0.356	0.508	0.014	0.020
b1	0.406	0.533	0.016	0.021
B	2.388	2.591	0.094	0.102
C	3.937	4.242	0.155	0.167
C1	0.787	1.194	0.031	0.047
D	4.394	4.597	0.173	0.181
D1	1.397	1.702	0.055	0.067
e	1.500 TYP.		0.060 TYP.	
H	0.356	0.432	0.014	0.017

SOT89-5 Surface Mount Package

SOT-223-3

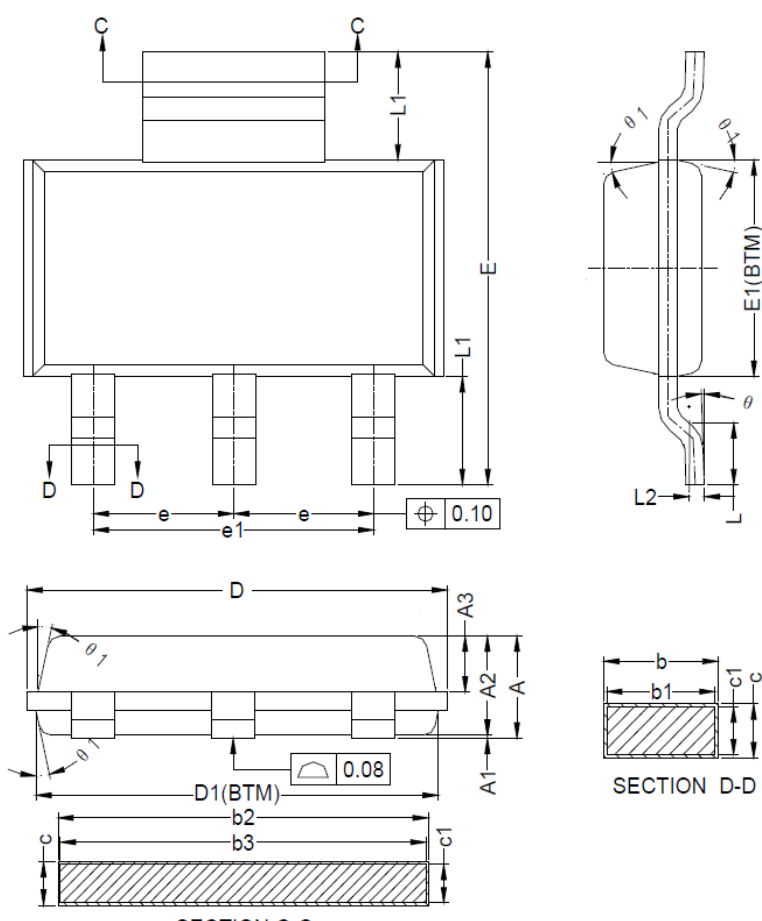
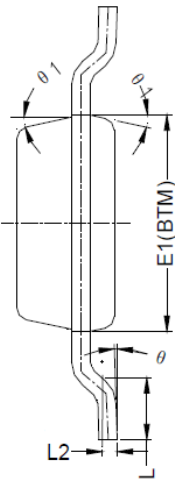
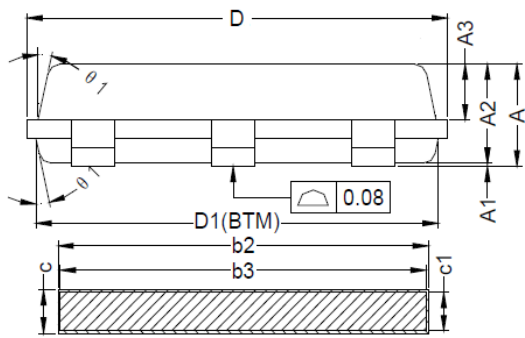
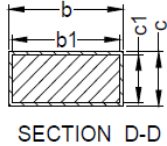
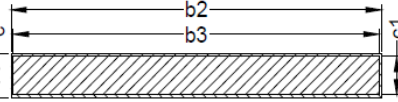
Package	SOT-223	Devices per reel	2500	Unit	mm																																																																																								
Package specification:																																																																																													
				<table border="1"> <thead> <tr> <th></th> <th>MIN</th> <th>NOM</th> <th>MAX</th> </tr> </thead> <tbody> <tr><td>A</td><td>1.50</td><td>1.65</td><td>1.80</td></tr> <tr><td>A1</td><td>0.02</td><td>0.06</td><td>0.10</td></tr> <tr><td>A2</td><td>1.45</td><td>1.60</td><td>1.75</td></tr> <tr><td>A3</td><td>0.80</td><td>0.90</td><td>1.00</td></tr> <tr><td>b</td><td>0.67</td><td>-</td><td>0.80</td></tr> <tr><td>b1</td><td>0.66</td><td>0.71</td><td>0.75</td></tr> <tr><td>b2</td><td>2.96</td><td>-</td><td>3.09</td></tr> <tr><td>b3</td><td>2.95</td><td>3.00</td><td>3.05</td></tr> <tr><td>c</td><td>0.30</td><td>-</td><td>0.35</td></tr> <tr><td>c1</td><td>0.29</td><td>0.30</td><td>0.31</td></tr> <tr><td>D</td><td>6.35</td><td>-</td><td>7.05</td></tr> <tr><td>D1</td><td>6.30</td><td>6.50</td><td>6.70</td></tr> <tr><td>E</td><td>6.80</td><td>7.00</td><td>7.20</td></tr> <tr><td>E1</td><td>3.40</td><td>3.50</td><td>3.60</td></tr> <tr><td>e</td><td colspan="3">2.30BSC</td></tr> <tr><td>e1</td><td colspan="3">4.60BSC</td></tr> <tr><td>L</td><td>0.80</td><td>1.00</td><td>1.20</td></tr> <tr><td>L1</td><td colspan="3">1.75REF</td></tr> <tr><td>L2</td><td colspan="3">0.25BSC</td></tr> <tr><td>θ</td><td>0°</td><td>-</td><td>8°</td></tr> <tr><td>θ 1</td><td>10°</td><td>12°</td><td>14°</td></tr> </tbody> </table>			MIN	NOM	MAX	A	1.50	1.65	1.80	A1	0.02	0.06	0.10	A2	1.45	1.60	1.75	A3	0.80	0.90	1.00	b	0.67	-	0.80	b1	0.66	0.71	0.75	b2	2.96	-	3.09	b3	2.95	3.00	3.05	c	0.30	-	0.35	c1	0.29	0.30	0.31	D	6.35	-	7.05	D1	6.30	6.50	6.70	E	6.80	7.00	7.20	E1	3.40	3.50	3.60	e	2.30BSC			e1	4.60BSC			L	0.80	1.00	1.20	L1	1.75REF			L2	0.25BSC			θ	0°	-	8°	θ 1	10°	12°	14°
	MIN	NOM	MAX																																																																																										
A	1.50	1.65	1.80																																																																																										
A1	0.02	0.06	0.10																																																																																										
A2	1.45	1.60	1.75																																																																																										
A3	0.80	0.90	1.00																																																																																										
b	0.67	-	0.80																																																																																										
b1	0.66	0.71	0.75																																																																																										
b2	2.96	-	3.09																																																																																										
b3	2.95	3.00	3.05																																																																																										
c	0.30	-	0.35																																																																																										
c1	0.29	0.30	0.31																																																																																										
D	6.35	-	7.05																																																																																										
D1	6.30	6.50	6.70																																																																																										
E	6.80	7.00	7.20																																																																																										
E1	3.40	3.50	3.60																																																																																										
e	2.30BSC																																																																																												
e1	4.60BSC																																																																																												
L	0.80	1.00	1.20																																																																																										
L1	1.75REF																																																																																												
L2	0.25BSC																																																																																												
θ	0°	-	8°																																																																																										
θ 1	10°	12°	14°																																																																																										
																																																																																													

Taping dimension:

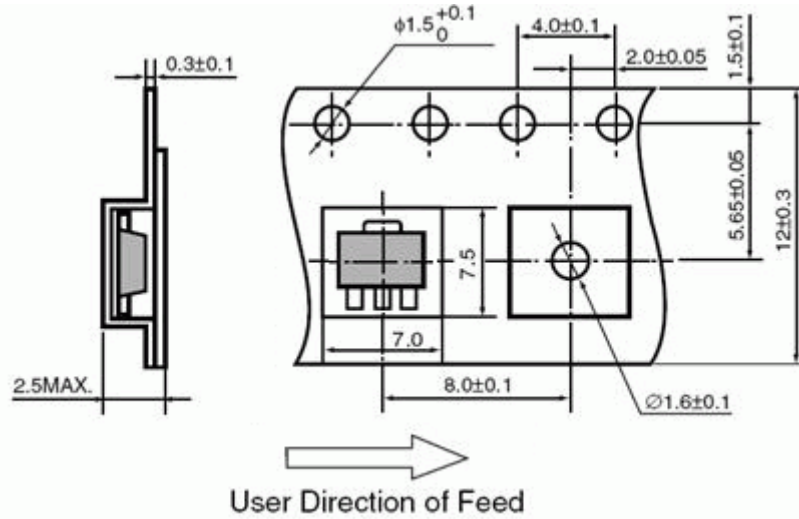

Taping reel dimension:

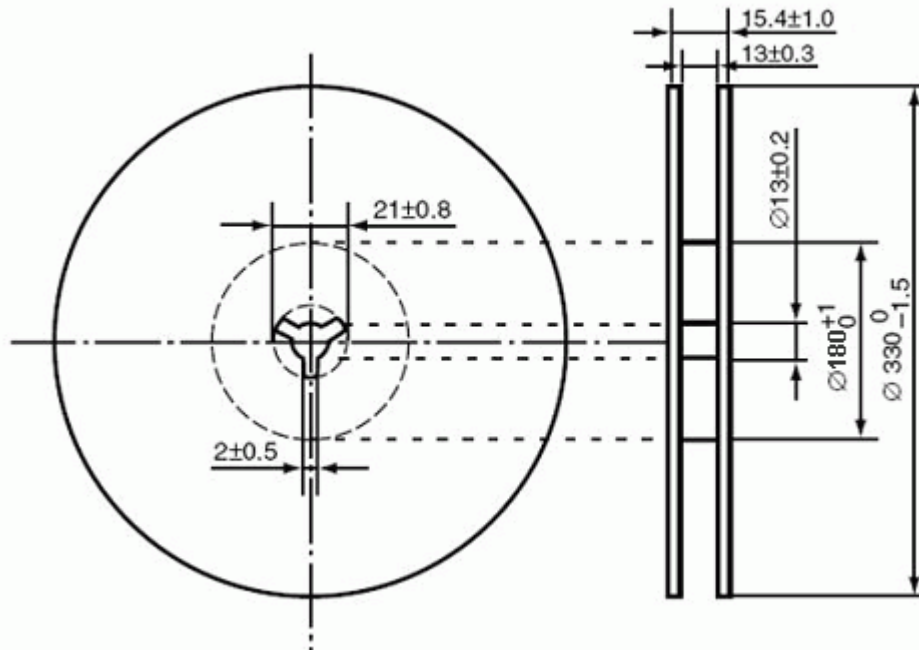

SOT-223-5

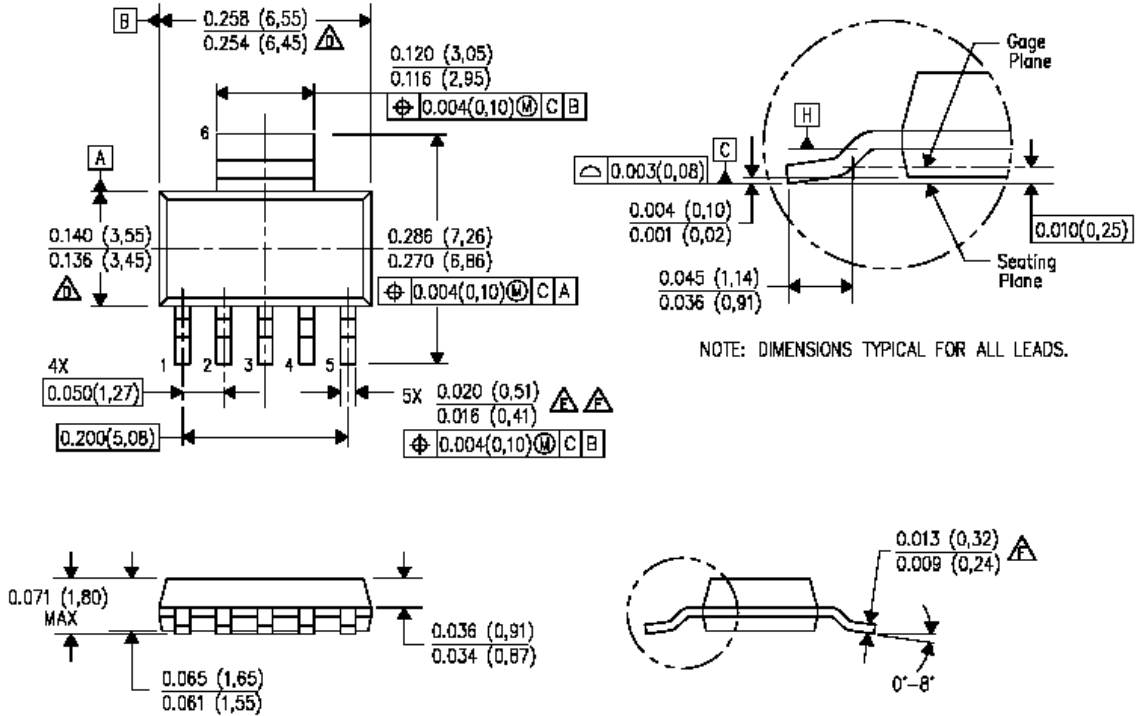

TO-252-3

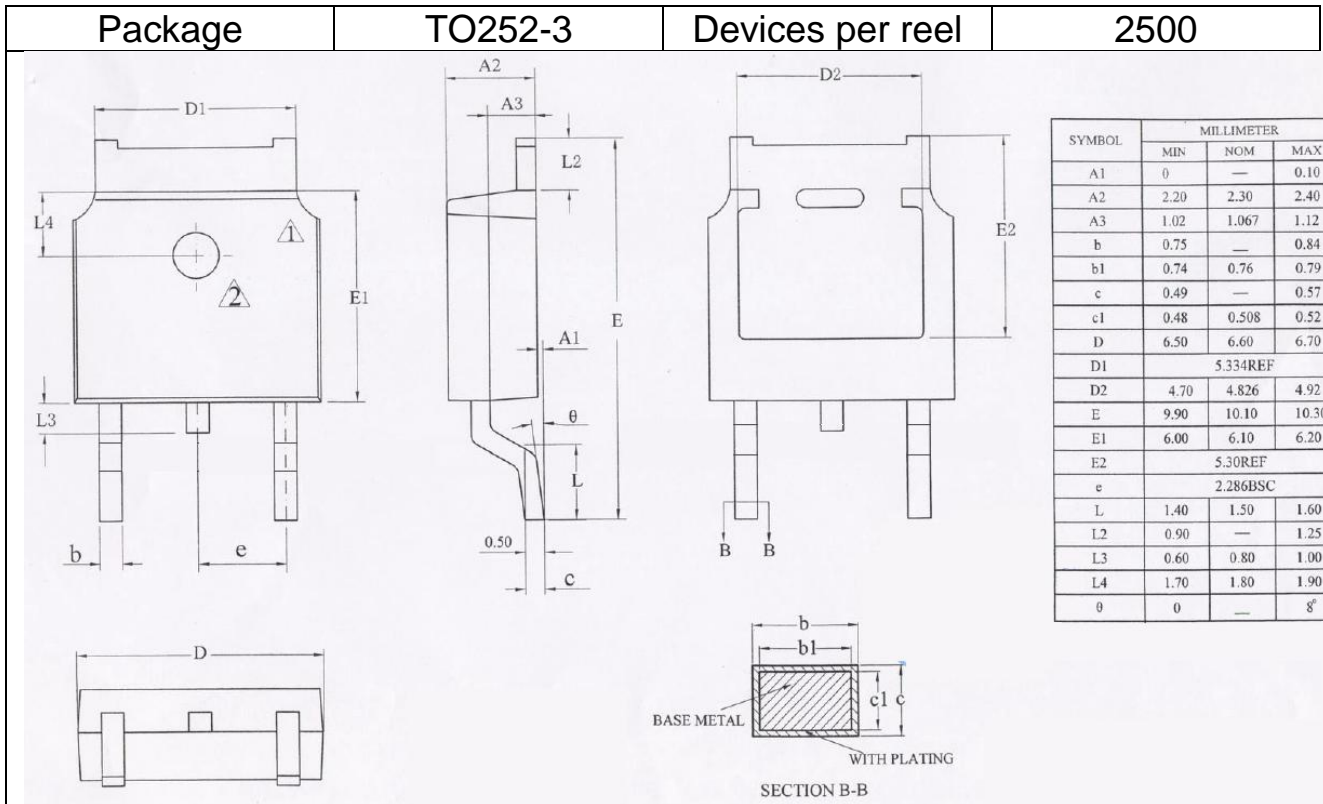

Taping dimension:

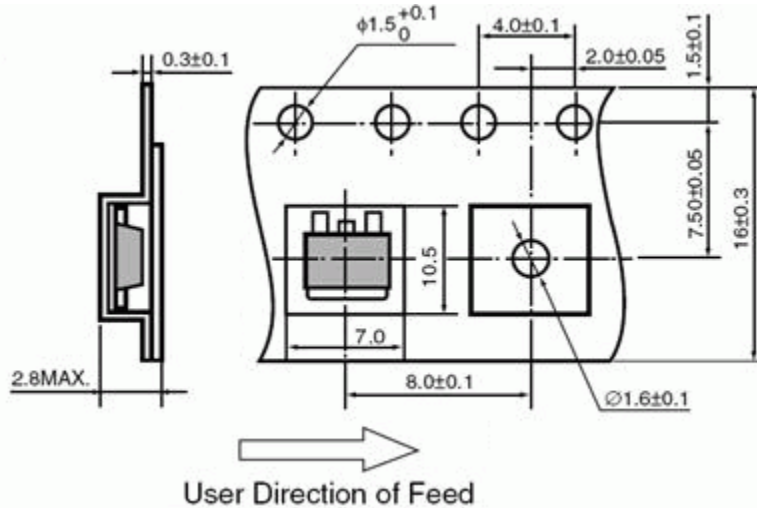

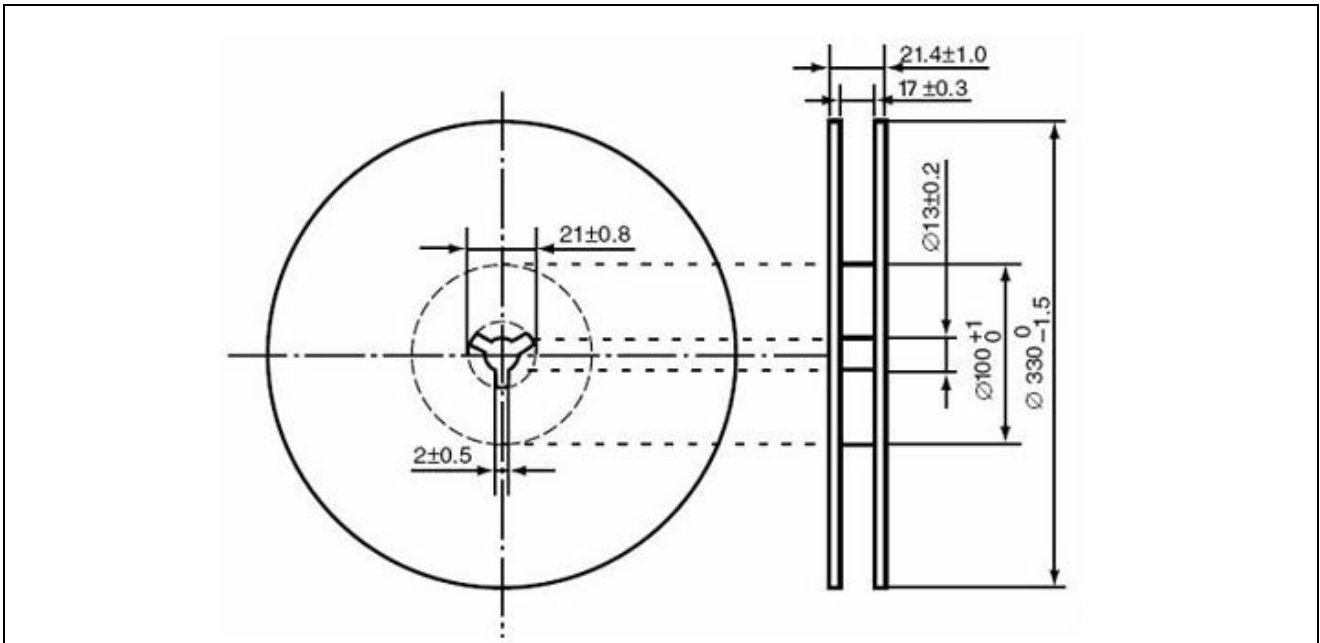

TO-252-5

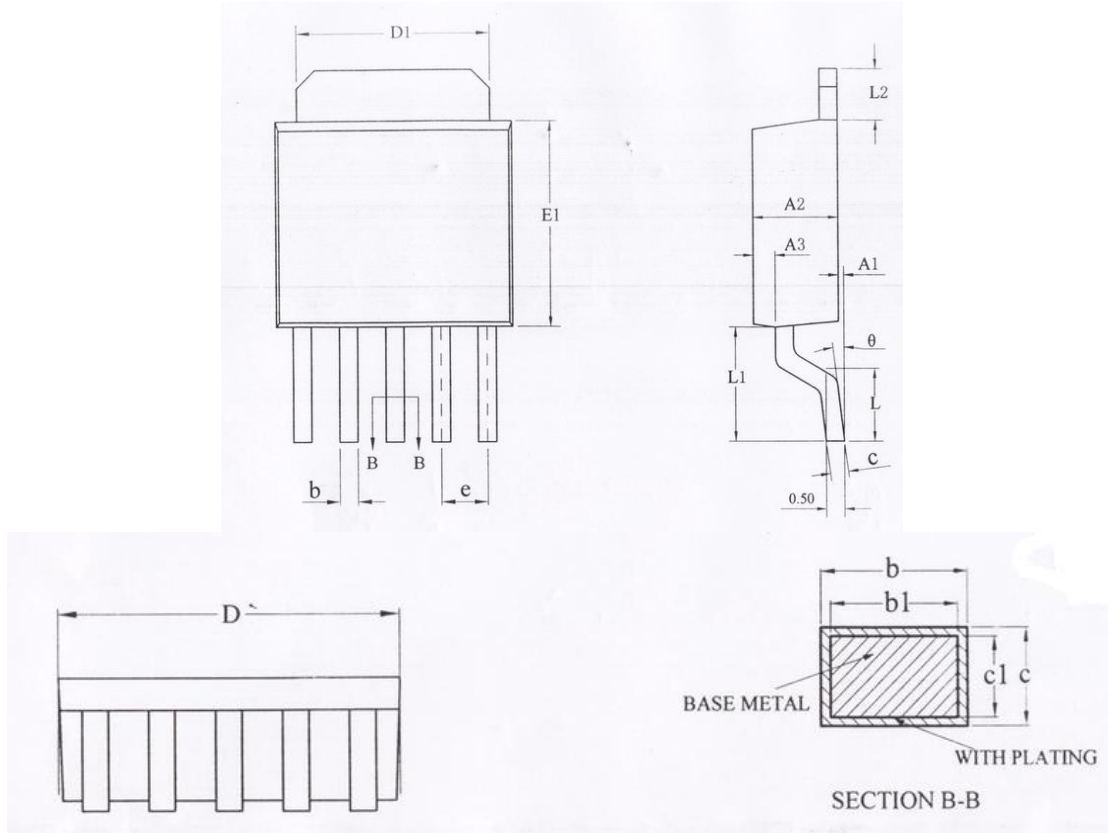

Symbol	Dimensions In Millimeters		
	MIN	NOM	MAX
A1	0.05	0.15	0.25
A2	2.1	2.3	2.5
A3	0.5	0.6	0.7
b	0.46		0.6
b1	0.45	0.5	0.55
c	0.49		0.56
c1	0.48	0.5	0.52
D	6.3	6.5	6.7
D1	5.30 REF		
E1	5.30	5.50	5.70
e	1.27BSC		
L	1.40	1.50	1.60
L1	3.0	3.1	3.2
L2	1.40BSC		
θ	0		8°

TO-263-3

TO-263

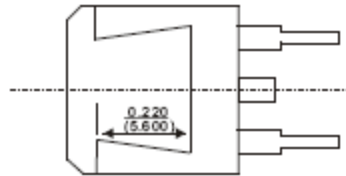
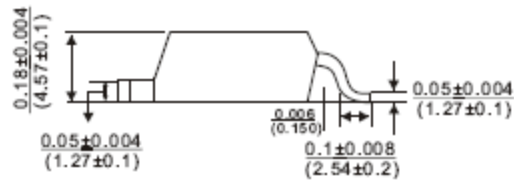
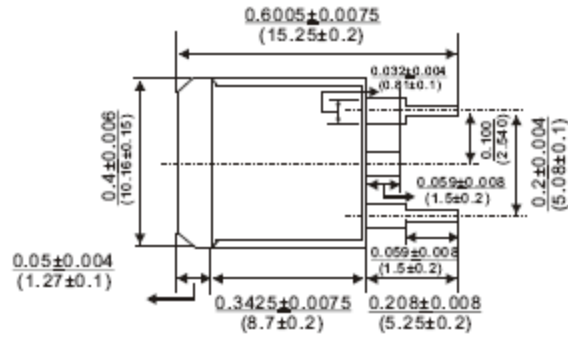

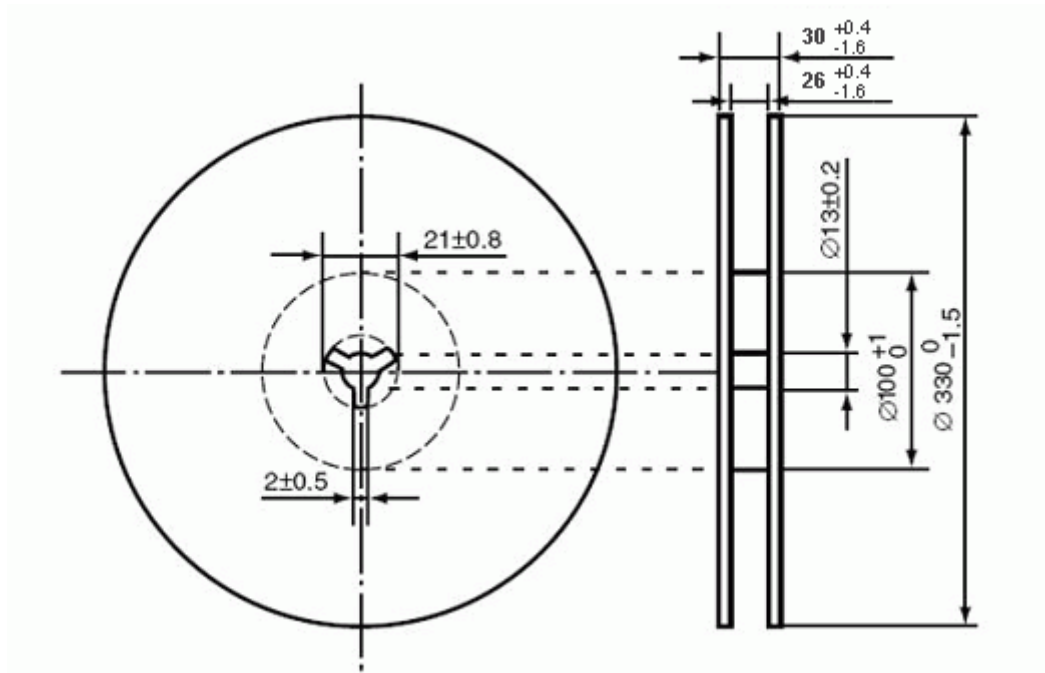
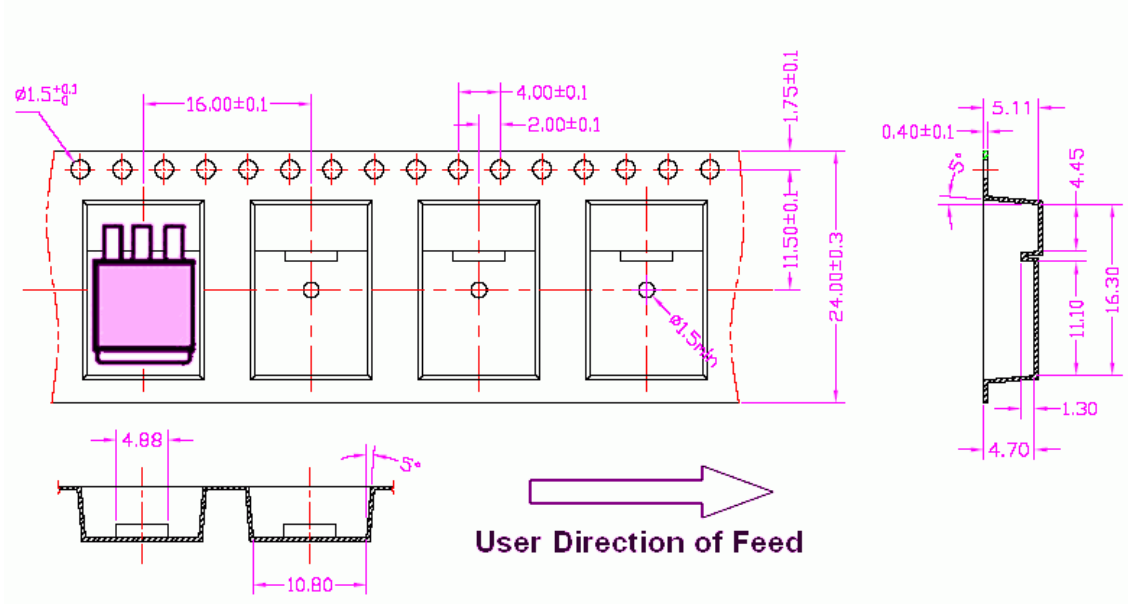

TO-220-3

Package specification:

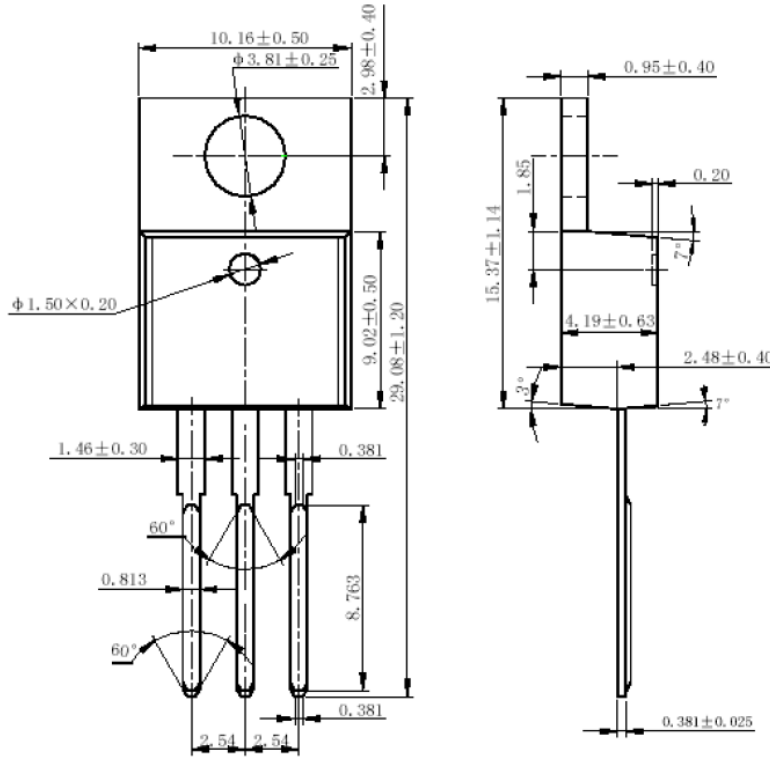

SOT-89-3

SOT-89-3L

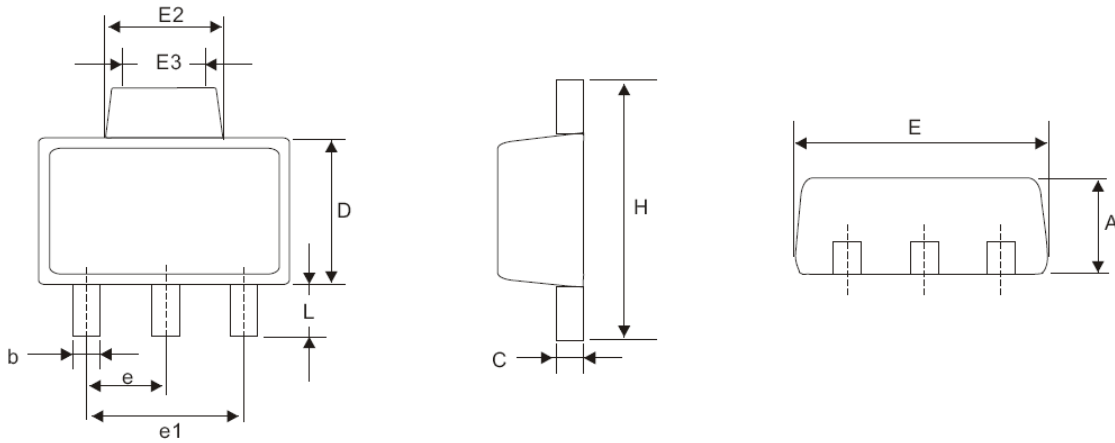

SYMBOL	MILLIMETERS		INCHES	
	MIN	MAX	MIN	MAX
A	1.450	1.500	0.057	0.061
b	0.440	0.480	0.017	0.019
C	0.360	0.400	0.014	0.016
E	4.450	4.550	0.175	0.179
E2	1.500	1.700	0.059	0.067
E3	1.400 Ref		0.055 Ref	
e	1.500 BSC		0.059 BSC	
e1	3.000 BSC		0.118 BSC	
D	2.450	2.550	0.096	0.100
H	4.150	4.250	0.163	0.167
L	0.900	1.100	0.035	0.043

TO92-3

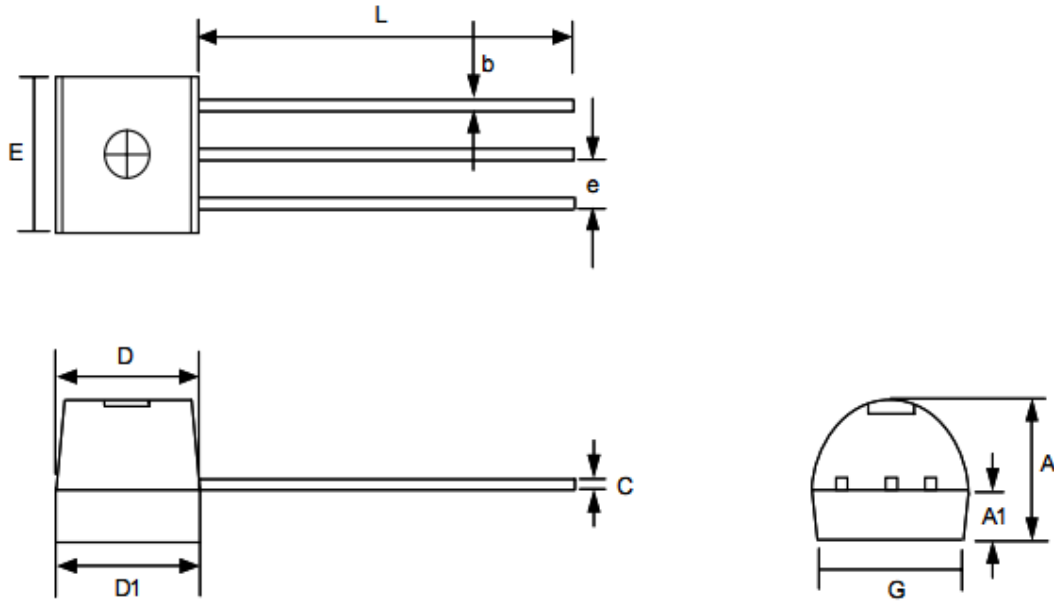

TO-92 (TD) Package

SYMBOL	MILLIMETER		INCH	
	MIN	MAX	MIN	MAX
A	3.35	3.86	0.132	0.152
A1	1.0414	1.55	0.041	0.061
b	0.254	0.508	0.010	0.020
E	4.34	4.85	0.171	0.191
C	0.254	0.508	0.010	0.020
L	14.53	15.04	0.572	0.592
e	1.143	1.397	0.045	0.055
G	3.683	4.191	0.145	0.165
D	4.29	4.80	0.169	0.189
D1	4.34	4.85	0.171	0.191