

Surface Mount Digital Step Attenuator

DAT-15575A Series

75Ω 0 to 15.5 dB, 0.5 dB Step 1MHz to 2.5 GHz

The Big Deal

- Wideband, operates up to 2.5 GHz
- Glitchless attenuation transitions
- High IP3, 52 dBm

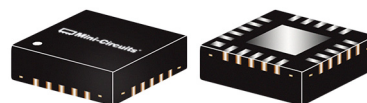

CASE STYLE: DG983-2

Product Overview

The DAT-15575A+ series of 75Ω digital step attenuators provides adjustable attenuation from 0 to 15.5 dB in 0.5 dB steps. The control is a 5-bit serial/parallel interface, and the attenuators operate with either single positive or dual (positive and negative) supply voltage. DAT-15575A+ series models are produced by a unique CMOS process on silicon, offering the performance of GaAs with the advantages of conventional CMOS devices.

Key Features

Feature	Advantages
Wideband operation, specified from 1MHz to 2.5 GHz	Can be used in multiple applications such as various versions of DOCSIS, satellite and defense, reducing part count.
Serial or parallel interface	Models available with serial or parallel interface mode to suit customer demand.
Good VSWR, 1.3:1 typ.	Eases interfacing with adjacent components and results in low amplitude ripple.
Single positive supply models: (Model suffixes: -SP+ and -PP+) +2.3 to +3.6V+	Use of single positive supply simplifies power supply design. An internal negative voltage generator supplies the desired negative voltage. Single positive supply results in excellent spurious performance, -140 dBm typical.
Dual supply models: (Model suffixes: -SN+ and -PN+) +2.7 to +3.6V (Positive) and -3.6 to -3.2V (Negative)	Dual supply provides spurious-free operation. It also allows fast switching up to 1 MHz (vs. 25 kHz for single supply).
Useable over a wide range of supply voltages, +2.3/2.7 to 5.2V	Wide range of positive operating voltages allows the DAT-15575A+ Series of models to be used in a wide range of applications. See Application Note AN-70-032 for operation above +3.6V
Footprint compatible to DAT-15575-XX+ Series (XX=SN/SP/PN/PP)	Can fit into existing footprint and provide wideband performance, to 2.5 GHz instead of 2.0 GHz.
Glitchless Attenuation Transitions, 0.26 typical	Compared to previous generation of digital attenuators which is a vast improvement.



Digital Step Attenuator

75Ω 1-2500 MHz

15.5 dB, 0.5 dB Step
5 Bit, Serial Control Interface, Dual Supply Voltages

Product Features

- Dual Supply (Positive & Negative) Voltages
- Immune to latch up
- Glitchless attenuation transitions
- Excellent accuracy, 0.1 dB Typ
- Serial control interface
- Low Insertion Loss
- High IP3, +55-69 dBm
- Excellent return loss, 18 dB typ.
- Very low DC power consumption
- Small size 4.0 x 4.0 mm

Typical Applications

- DOCSIS 3.1
- Portable Wireless
- Fiber CPE and infrastructure
- MMDS & Wireless LAN
- Satellite CPE and infrastructure
- UNII & Hiper LAN
- Power amplifier distortion canceling loop

General Description

The DAT-15575A-SN+ is a 75Ω RF digital step attenuator that offers an attenuation range up to 15.5 dB in 0.5 dB steps. The control is a 5-bit serial interface, operating on dual (positive and negative) supply voltages. The DAT-15575A-SN+ is produced using a unique CMOS process on silicon, offering the performance of GaAs, with the advantages of conventional CMOS devices.

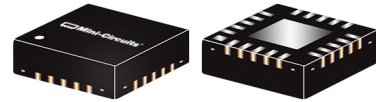

DAT-15575A-SN+

CASE STYLE: DG983-2

+RoHS Compliant

The +Suffix identifies RoHS Compliance. See our web site for RoHS Compliance methodologies and qualifications

Simplified Schematic

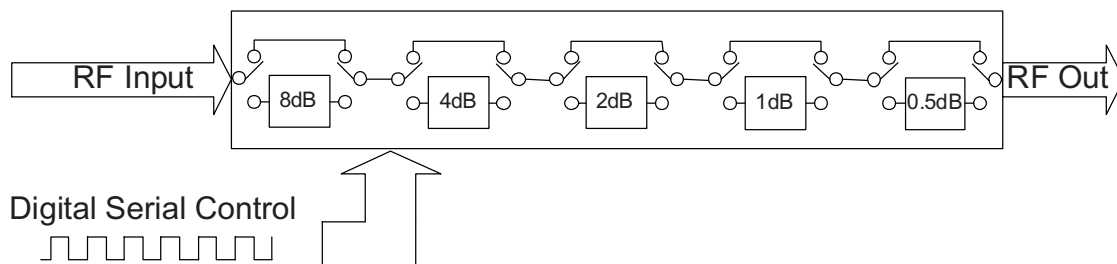

RF Electrical Specifications, 1-2500 MHz, T_{AMB}=25°C, V_{DD}=+3V, V_{SS}=-3.2V, 75Ω

Parameter	Freq. Range (GHz)	Min.	Typ.	Max.	Units
Accuracy @ 0.5 dB Attenuation Setting	0.001-1.2	—	0.03	0.17	dB
	1.2-2.0	—	0.05	0.18	
	2.0-2.5	—	0.1	0.19	
Accuracy @ 1 dB Attenuation Setting	0.001-1.2	—	0.03	0.18	dB
	1.2-2.0	—	0.1	0.20	
	2.0-2.5	—	0.1	0.23	
Accuracy @ 2 dB Attenuation Setting	0.001-1.2	—	0.07	0.21	dB
	1.2-2.0	—	0.15	0.26	
	2.0-2.5	—	0.15	0.31	
Accuracy @ 4 dB Attenuation Setting	0.001-1.2	—	0.05	0.27	dB
	1.2-2.0	—	0.15	0.36	
	2.0-2.5	—	0.2	0.47	
Accuracy @ 8 dB Attenuation Setting	0.001-1.2	—	0.1	0.39	dB
	1.2-2.0	—	0.24	0.60	
	2.0-2.5	—	0.35	0.79	
Insertion Loss ¹ @ all attenuator set to 0dB	0.001-1.2	—	1.2	1.8	dB
	1.2-2.5	—	1.6	1.9	
VSWR	0.001-1.2	—	1.3	—	:1
	1.2-2.5	—	1.4	—	
Input IP3 (at Min. and Max. Attenuation)	.005-2.5	—	55-69	—	dBm
Input IP2	.005-2.5	—	See Fig. 1	—	dBm
Input Power @ 0.2dB Compression (at Min. and Max. Attenuation)	0.030-2.5	—	+30	—	dBm
Input Operating Power	1 MHz to 30 MHz	—	—	See Fig. 2	dBm
	>30 MHz	—	—	+24	
Thermal Resistance (Junction to case)	—	—	25	—	°C/W

DC Electrical Specifications

Parameter	Min.	Typ.	Max.	Units
V _{DD} , Supply Voltage	2.7	3	3.6 ²	V
I _{DD} Supply Current	—	—	80	μA
Control Input Low	-0.3	—	0.6 ³	V
V _{SS} , Supply Voltage	-3.6	—	-3.2	V
I _{SS} , Supply Current	-40	—	—	μA
Control Input High	1.17	—	3.6	V
Control Current	—	—	20	μA

1. I. Loss values are de-embedded from test board Loss (test board's Insertion Loss: 0.10dB @ 100MHz, 0.40dB @ 1200MHz, 0.55dB @ 2000MHz, 0.75dB @ 4000MHz).
2. For operation above +3.6V see application note, AN-70-032
3. 0V during power-up.

Absolute Maximum Ratings⁴

Parameter	Ratings
Operating Temperature	-40°C to 105°C
Storage Temperature	-65°C to 150°C
V _{DD}	-0.3V Min., 5.5V Max.
V _{SS}	-3.8V Min.
Voltage on any input	-0.3V Min., 3.6V Max.
Input Power	1-30 MHz
	30-2500MHz
	Figure 2
	+30dBm

4. Permanent damage may occur if any of these limits are exceeded.
5. Operation between max operating and absolute max input power will result in reduced reliability.

Switching Specifications

Parameter	Min.	Typ.	Max.	Units
Switching Speed, 50% Control to 0.5dB of Attenuation Value	—	0.4	0.7	μSec
Switching Control Frequency	—	1.0	—	MHz

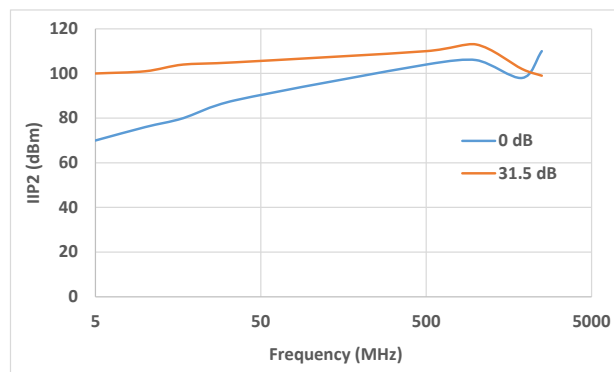

Figure 1. IP2 vs. frequency and attenuation

Pin Description

Function	Pin Number	Description
N/C	1	Not connected (Note 8)
RF in	2	RF in port (Note 1)
Data	3	Serial Interface data input (Note 3)
Clock	4	Serial Interface clock input
LE	5	Latch Enable Input (Note 2)
V _{DD}	6	Power Supply
N/C	7	Not connected (Note 7)
N/C	8	Not connected
V _{DD}	9	Power Supply
GND	10	Ground connection
GND	11	Ground connection
V _{SS}	12	Negative Supply Voltage
V _{DD}	13	Power Supply
RF out	14	RF out port (Note 1)
C8	15	Control for attenuation bit, 8 dB (Note 4)
C4	16	Control for attenuation bit, 4 dB (Note 4)
C2	17	Control for attenuation bit, 2 dB (Note 4)
GND	18	Ground Connection
C1	19	Control for attenuation bit, 1 dB (Note 4)
C0.5	20	Control for attenuation bit, 0.5 dB (Note 4, 7)
GND	Paddle	Paddle ground (Note 5)

Notes:

- Both RF ports must be held at 0VDC or DC blocked with an external series capacitor. RF in and RF out are interchangeable.
- Latch Enable (LE) has an internal 2MΩ pull-up resistor to V_{DD}.
- Place a 10KΩ resistor in series to be compatible with previous generation of models. 10KΩ can be omitted in new designs.
- Refer to Power-up Control Settings.
- The exposed solder pad on the bottom of the package (See Pin configuration) must be grounded for proper device operation.
- N/A
- This pin has internal 1MΩ short resistor to ground.
- Place 10KΩ resistor to ground externally.

Pin Configuration (Top View)

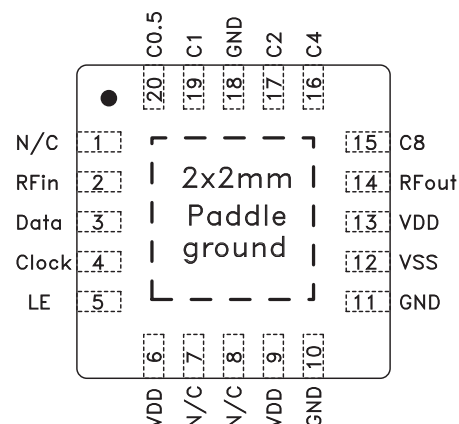

Device Marking

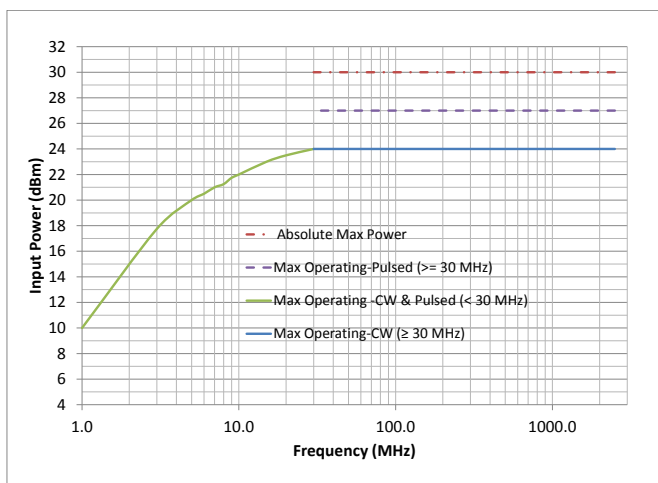
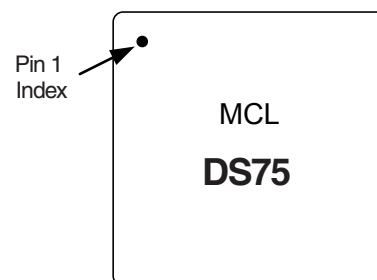
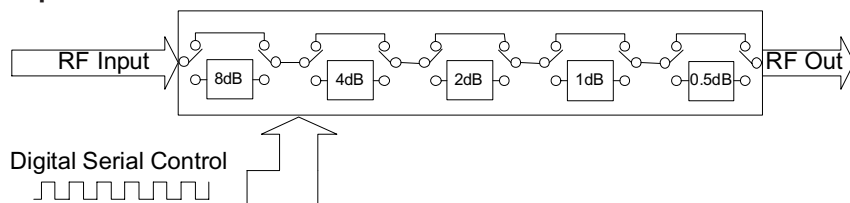

Figure 2. Max Input power vs. frequency.
Pulsed Power: 5% duty cycle, 4620 μS period

Simplified Schematic



The DAT-15575A-SN+ Serial interface consists of 5 control bits that select the desired attenuation state, as shown in **Table 1**: Truth Table

Attenuation State	C8	C4	C2	C1	C0.5
Reference	0	0	0	0	0
0.5 (dB)	0	0	0	0	1
1 (dB)	0	0	0	1	0
2 (dB)	0	0	1	0	0
4 (dB)	0	1	0	0	0
8 (dB)	1	0	0	0	0
15.5 (dB)	1	1	1	1	1

Note: Not all 32 possible combinations of C0.5 - C8 are shown in table

The serial interface is a 5-bit serial in, parallel-out shift register buffered by a transparent latch.

It is controlled by three CMOS-compatible signals: Data, Clock, and Latch Enable (LE). The Data and Clock inputs allow data to be serially entered into the shift register, a process that is independent of the state of the LE input.

The LE input controls the latch. When LE is HIGH, the latch is transparent and the contents of the serial shift register control the attenuator. When LE is brought LOW, data in the shift register is latched.

The shift register should be loaded while LE is held LOW to prevent the attenuator value from changing as data is entered. The LE input should then be toggled HIGH and brought LOW again, latching the new data. The timing for this operation is defined by **Figure 3** (Serial Interface Timing Diagram) and **Table 2** (Serial Interface AC Characteristics).

Figure 3: Serial Interface Timing Diagram

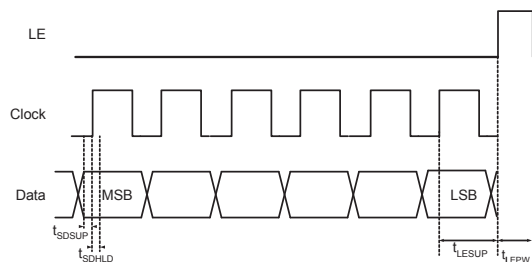

Symbol	Parameter	Min.	Max.	Units
f_{clk}	Serial data clock frequency (Note 1)		10	MHz
t_{clkH}	Serial clock HIGH time	30		ns
t_{clkL}	Serial clock LOW time	30		ns
t_{LESUP}	LE set-up time after last clock falling edge	10		ns
t_{LEPW}	LE minimum pulse width	30		ns
t_{SDSUP}	Serial data set-up time before clock rising edge	10		ns
t_{SDHLD}	Serial data hold time after clock falling edge	10		ns

Note 1. fclk verified during the functional pattern test. Serial programming sections of the functional pattern are clocked at 10MHz to verify fclk specification.

The DAT-15575A-SN+, uses a common 5-bit serial word format, as shown in **Table 3**: 5-Bit attenuator Serial Programming Register Map.

The bit B4, corresponds to the 8-dB Step and the last bit, the LSB, corresponds to the 0.5 dB step.

B5	B4	B3	B2	B1	B0
0	C8	C4	C2	C1	C0.5

↑

MSB
(first in)

↑

LSB
(last in)

Power-up Control Settings

The DAT-15575A-SN+ always assumes a specifiable attenuation setting on power-up, allowing a known attenuation state to be established before an initial serial control word is provided.

When the attenuator powers up, the five control bits are set to whatever data is present on the six data inputs (C0.5 to C8).

This allows any one of the 32 attenuation settings to be specified as the power-up state.

TB-343 Evaluation Board Schematic Diagram

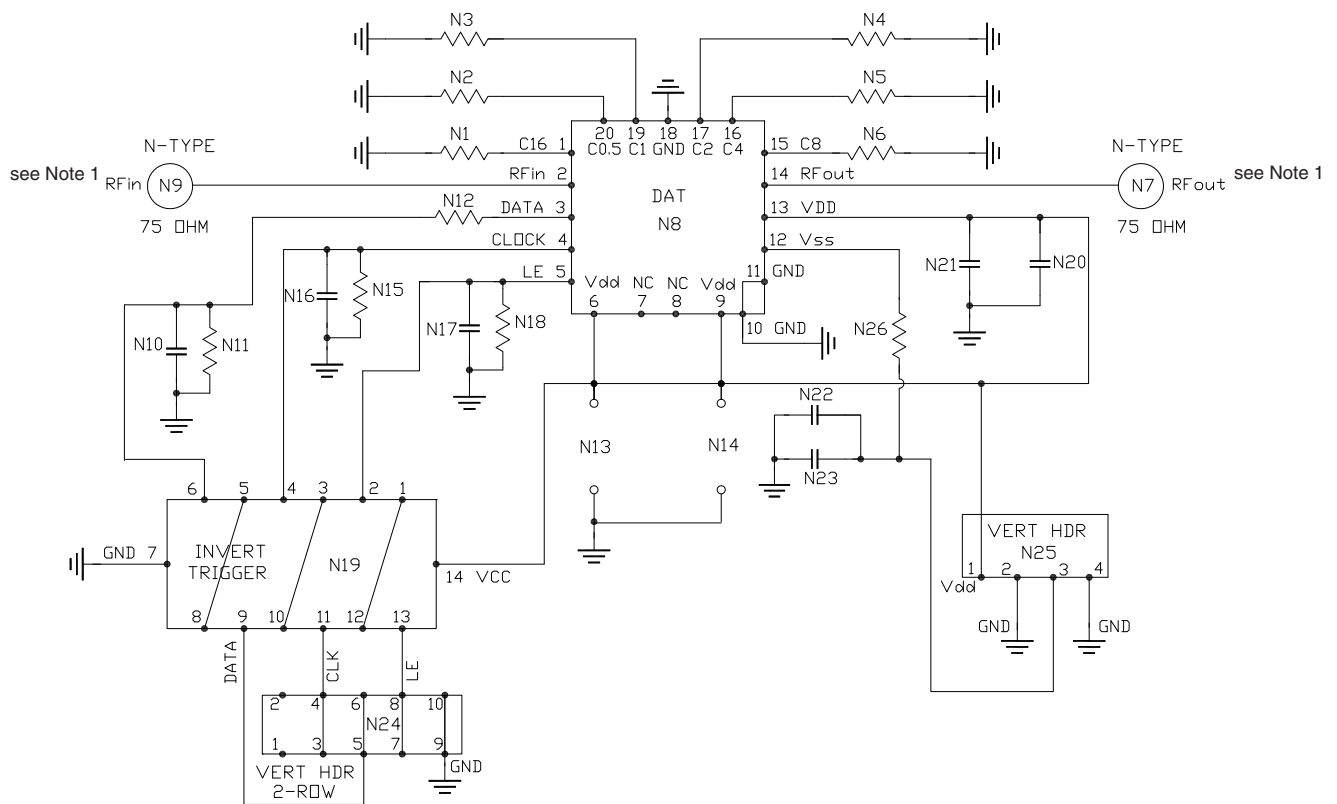

Note 1: Both RF ports must be held at 0VDC or DC blocked with an external series capacitor.

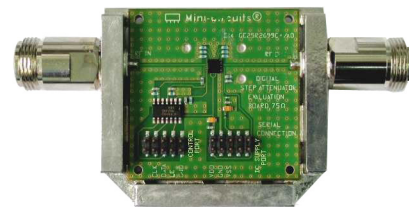

TB-343

Bill of Materials	
N1-N6, N11, N12, N15, N18	Resistor 0603 10 KOhm +/- 1%
N10, N16, N17, N20	NPO Capacitor 0603 100pF +/- 5%
N21	Tantalum Capacitor 0805 100nF +/- 10%
N19	Hex Invert Schmitt Trigger MSL1

**N12 can be reduced to 0 Ohms

Additional Detailed Technical Information

additional information is available on our dash board. To access this information [click here](#)

Performance Data	Data Table
	Swept Graphs
	S-Parameter (S2P Files) Data Set (.zip file)
Case Style	DG983-2 <i>Plastic package, exposed paddle, lead finish: NiPdAu</i>
Tape & Reel Standard quantities available on reel	F87 <i>7" reels with 20, 50, 100 or 200 devices</i> <i>13" reels with 3K devices</i>
Suggested Layout for PCB Design	PL-202
Evaluation Board	TB-343
Environmental Ratings	ENV33T1

ESD Rating

Human Body Model (HBM): Class 1C (1000 to <2000V) in accordance with MIL-STD-883 method 3015 (pass 1500V).

Charge Device Model (CDM): Class C3 (>1000V) per JESD22-C101F

MSL Rating

Moisture Sensitivity: MSL1 in accordance with IPC/JEDEC J-STD-020D

MSL Test Flow Chart

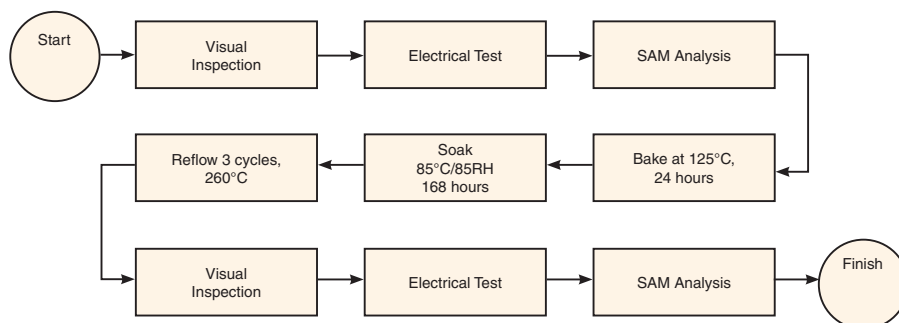

Additional Notes

- Performance and quality attributes and conditions not expressly stated in this specification document are intended to be excluded and do not form a part of this specification document.
- Electrical specifications and performance data contained in this specification document are based on Mini-Circuits' applicable established test performance criteria and measurement instructions.
- The parts covered by this specification document are subject to Mini-Circuits standard limited warranty and terms and conditions (collectively, "Standard Terms"); Purchasers of this part are entitled to the rights and benefits contained therein. For a full statement of the Standard Terms and the exclusive rights and remedies thereunder, please visit Mini-Circuits' website at www.minicircuits.com/MCLStore/terms.jsp