



Features

- ◇ Small surface mounting type
- ◇ High reliability
- ◇ Low current operation at 250uA

Applications

- ◇ Voltage stabilization

MINI MELF

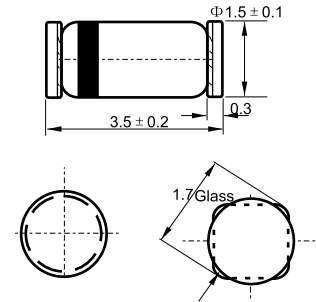

Dimension in millimeters

Absolute Maximum Ratings

T_j=25°C

Parameter	Test Conditions	Type	Symbol	Value	Unit
Power dissipation	R _{thJA} ≤ 300K/W		P _V	500	mW
Z-current			I _Z	P _V /V _Z	mA
Junction temperature			T _j	175	°C
Storage temperature range			T _{stg}	-65~+175	°C

Stresses exceeding maximum ratings may damage the device. Maximum ratings are stress ratings only. Functional operation above the recommended operating conditions is not implied. Extended exposure to stresses above the recommended operating conditions may affect device reliability.

Electrical Characteristics

T_j=25°C

Parameter	Test Conditions	Type	Symbol	Min	Typ	Max	Unit
Forward voltage	I _F =200mA		V _F			1.1	V

Type No.	Nominal Zener Voltage $V_Z @ I_{ZT}^{1)}$	Test Current I_{ZT}	Maximum Zener Impedance $Z_{ZT} @ I_{ZT}^{2)}$	Maximum Leakage Current $I_R @ V_R$		Maximum Noise Density Impedance $N_D @ I_{ZT}^{2)}$	Maximum Zener Current $I_{ZM}^{3)}$	Maximum Temp Coeff. of Zener Voltage α_{VZ}
	V	μA	Ω	μA	V	$\mu V \sqrt{Hz}$	mA	%/°C
LL4620	3.3	250	1650	7.5	1.5	1	85	-0.075
LL4621	3.6	250	1700	7.5	2	1	83	-0.065
LL4622	3.9	250	1650	5.0	2	1	80	-0.060
LL4623	4.3	250	1600	4.0	2	1	77	-0.050
LL4624	4.7	250	1550	10.0	3	1	75	-0.05~0.02
LL4625	5.1	250	1500	10.0	3	2	70	-0.045~0.03
LL4626	5.6	250	1400	10.0	4	4	65	-0.02~0.04
LL4627	6.2	250	1200	10.0	5	5	61	-0.01~0.05
LL4099	6.8	250	200	10.0	5.17	40	56	0.06
LL4100	7.5	250	200	10.0	5.70	40	51	0.065
LL4101	8.2	250	200	1.0	6.24	40	46	0.070
LL4102	8.7	250	200	1.0	6.61	40	44	0.075
LL4103	9.1	250	200	1.0	6.92	40	42	0.080
LL4104	10	250	200	1.0	7.60	40	38	0.080
LL4105	11	250	200	0.05	8.44	40	35	0.080
LL4106	12	250	200	0.05	9.12	40	32	0.080
LL4107	13	250	200	0.05	9.87	40	29	0.080
LL4108	14	250	200	0.05	10.65	40	27	0.085
LL4109	15	250	100	0.05	11.40	40	25	0.085
LL4110	16	250	100	0.05	12.15	40	24	0.085
LL4111	17	250	100	0.05	12.92	40	22	0.090
LL4112	18	250	100	0.05	13.67	40	21	0.090
LL4113	19	250	150	0.05	14.44	40	20	0.090
LL4114	20	250	150	0.01	15.20	40	19	0.090
LL4115	22	250	150	0.01	16.72	40	17	0.090
LL4116	24	250	150	0.01	18.25	40	16	0.090
LL4117	25	250	150	0.01	19.00	40	15	0.090
LL4118	27	250	150	0.01	20.45	40	14	0.090
LL4119	28	250	200	0.01	21.28	40	14	0.095
LL4120	30	250	200	0.01	22.80	40	13	0.095
LL4121	33	250	200	0.01	25.08	40	12	0.095
LL4122	36	250	200	0.01	27.38	40	11	0.095
LL4123	39	250	200	0.01	29.65	40	9.8	0.095
LL4124	43	250	250	0.01	32.65	40	8.9	0.095
LL4125	47	250	250	0.01	35.75	40	8.1	0.095

- 1) The type numbers shown above have a standard tolerance of $\pm 5\%$ on the nominal Zener voltage. Also available in 2% and 1% tolerance, suffix C and D respectively. V_Z is measured with the diode in thermal equilibrium in 25°C still air.
- 2) Zener impedance is derived by superimposing on I_{ZT} , a 60Hz rms a.c. current equal to 10% of I_{ZT} (25 μA a.c.)
- 3) Based upon 400 mW maximum power dissipation at 75°C lead temperature, allowance has been made for the higher voltage associated with operation at higher currents.