

SM220 THRU SM260

VOLTAGE RANGE - 20 to 60 Volts

CURRENT - 2.0 Amperes



FEATURES

- * High current capability
- * Ideal for surface mounted applications
- * Low leakage current for high efficiency



SM-1(DO-213AB)

MECHANICAL DATA

- * Case: Molded plastic
- * Epoxy: UL 94V-0 rate flame retardant
- * Terminals: Solder plated solderable per MIL-STD-202E, Method 208 guaranteed
- * Polarity: Color band denotes cathode end
- * Mounting position: Any
- * Weight: 0.12 gram

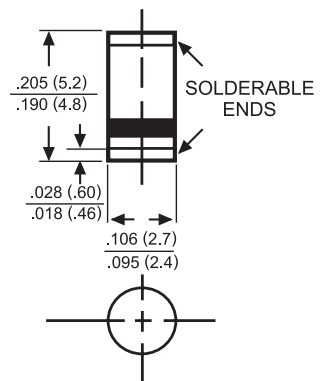

Dimensions in inches and (millimeters)

MAXIMUM RATINGS AND ELECTRICAL CHARACTERISTICS

Ratings at 25 °C ambient temperature unless otherwise specified.

Single phase, half wave, 60 Hz, resistive or inductive load.

For capacitive load, derate current by 20%.

	SYMBOL	SM220	SM230	SM240	SM250	SM260	UNITS
Maximum Recurrent Peak Reverse Voltage	V _{RRM}	20	30	40	50	60	Volts
Maximum RMS Voltage	V _{RMS}	14	21	28	35	42	Volts
Maximum DC Blocking Voltage	V _{DC}	20	30	40	50	60	Volts
Maximum Average Forward Rectified Current at T _A =90°C	I _O	2.0					Amps
Peak Forward Surge Current 8.3 ms single half sine-wave superimposed on rated load (JEDEC Method)	I _{FSM}	40					Amps
Maximum Instantaneous Forward Voltage at 2.0A DC	V _F	.45	.55	.60	.75		
Maximum DC Reverse Current at @ T _A = 25°C	I _R	2.0					mAmps
Rated DC Blocking Voltage @ T _A = 100°C		20					
Typical Thermal Resistance (Note1)	R _{θJA}	40					°C/W
Typical Junction Capacitance (Note 2)	C _J	200					pF
Storage Operating Temperature Range	T _J , T _{STG}	-65 to + 125					°C

- NOTES : 1. Thermal Resistance (Junction to Ambient), .24in₂ (6.0mm₂) copper pads to each terminal.
2. Measured at 1 MHz and applied reverse voltage of 4.0 volts.

www.dgnjdz.com

RATING AND CHARACTERISTIC CURVES (SM220 THRU SM260)

FIG. 1 - TYPICAL FORWARD CURRENT DERATING CURVE

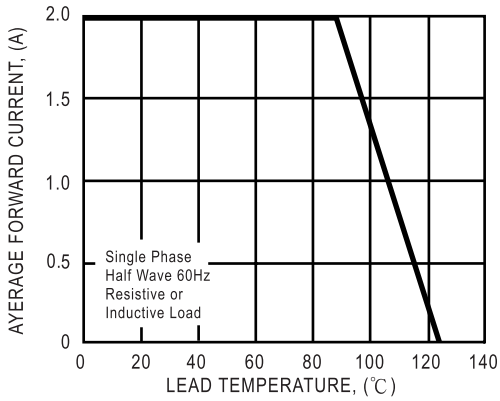

FIG. 2 - TYPICAL INSTANTANEOUS FORWARD CHARACTERISTICS

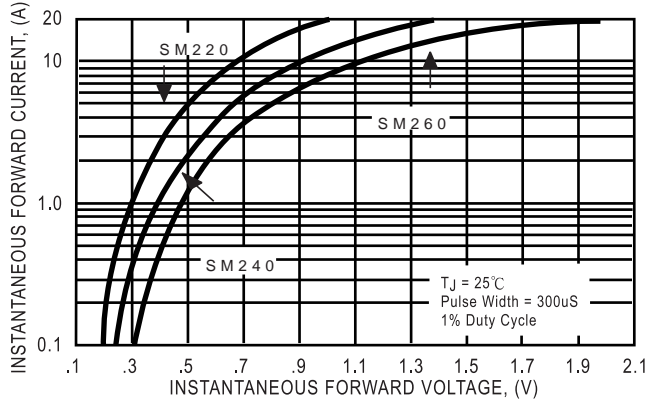

FIG. 3 - TYPICAL REVERSE CHARACTERISTICS

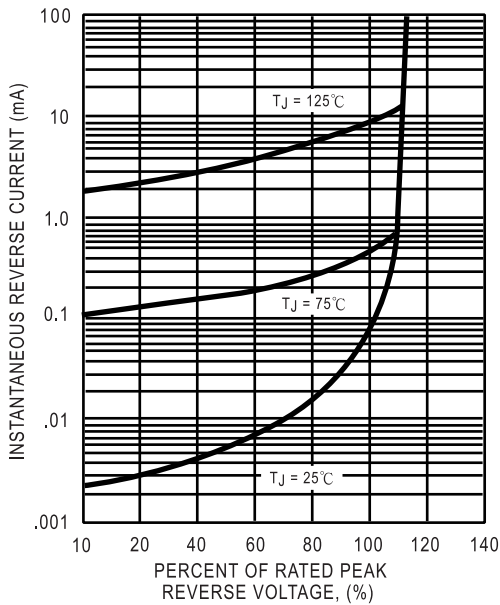

FIG. 4 - MAXIMUM NON-REPETITIVE FORWARD SURGE CURRENT

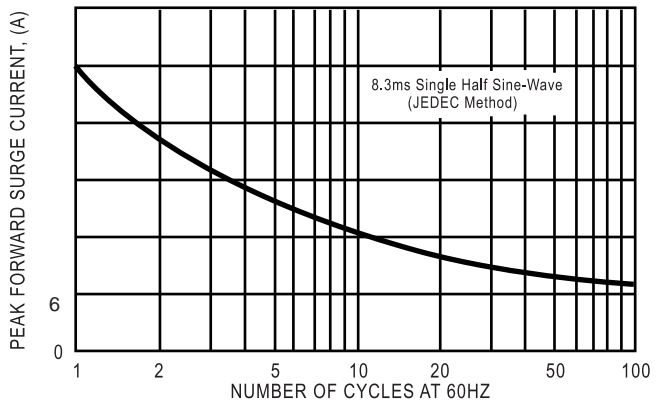

FIG. 5 - TYPICAL JUNCTION CAPACITANCE

