

isc N-Channel MOSFET Transistor

2SK846

DESCRIPTION

- Drain Current $-I_D=3A @ T_C=25^\circ C$
- Drain Source Voltage-
: $V_{DSS}= 900V(\text{Min})$

APPLICATIONS

- high voltage, high speed power switching

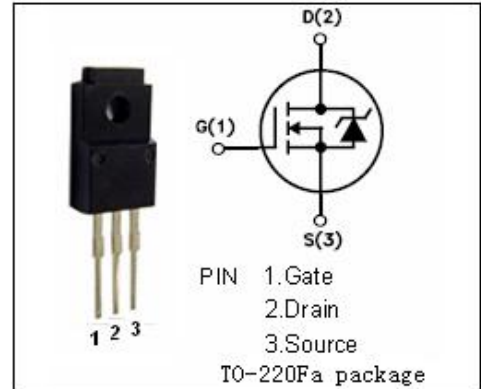

ABSOLUTE MAXIMUM RATINGS($T_a=25^\circ C$)

SYMBOL	PARAMETER	VALUE	UNIT
V_{DSS}	Drain-Source Voltage ($V_{GS}=0$)	900	V
V_{GS}	Gate-Source Voltage	± 20	V
I_D	Drain Current-continuous@ $T_C=25^\circ C$	5	A
P_{tot}	Total Dissipation@ $T_C=25^\circ C$	45	W
T_j	Max. Operating Junction Temperature	150	$^\circ C$
T_{stg}	Storage Temperature Range	-55~150	$^\circ C$

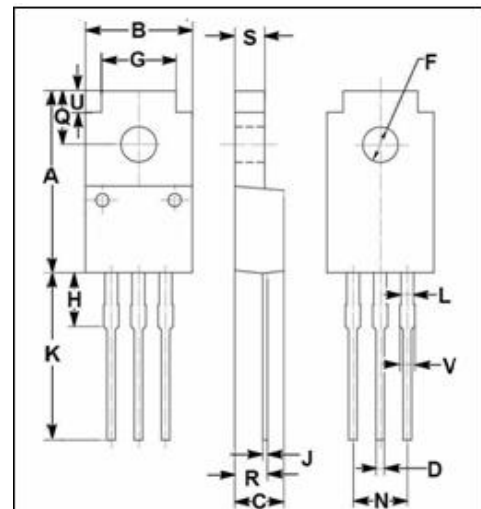

DIM	mm	
	MIN	MAX
A	16.85	17.15
B	9.90	10.10
C	4.35	4.65
D	0.75	0.80
F	3.20	3.40
G	6.90	7.10
H	5.15	5.45
J	0.45	0.75
K	13.35	13.65
L	1.10	1.30
N	4.98	5.18
Q	4.85	5.15
R	2.95	3.25
S	2.70	2.90
U	1.75	2.05
V	1.30	1.50

THERMAL CHARACTERISTICS

SYMBOL	PARAMETER	MAX	UNIT
$R_{th j-c}$	Thermal Resistance, Junction to Case	1.0	$^\circ C/W$
$R_{th j-a}$	Thermal Resistance, Junction to Ambient	62.5	$^\circ C/W$

isc N-Channel Mosfet Transistor**2SK846****• ELECTRICAL CHARACTERISTICS (T_C=25°C)**

SYMBOL	PARAMETER	CONDITIONS	MIN	TYP	MAX	UNIT
V _{(BR)DSS}	Drain-Source Breakdown Voltage	V _{GS} =0; I _D = 10mA	900			V
V _{GS(th)}	Gate Threshold Voltage	V _{DS} =0; I _D =1mA	2.0		4.0	V
R _{DS(on)}	Drain-Source On-stage Resistance	V _{GS} =10V; I _D =1.5A			4.0	Ω
I _{GSS}	Gate Source Leakage Current	V _{GS} = ±20V; V _{DS} = 0			± 100	nA
I _{DSS}	Zero Gate Voltage Drain Current	V _{DS} =900V; V _{GS} = 0			0.1	mA