

LED Driver for High Power LEDs

ILD4071

700mA High Integration - DC/DC Step-Down Converter

Datasheet

Rev. 1.0, 2011-11-16

Table of Contents

1	Overview	3
2	Block Diagram	5
3	Pin Configuration	6
3.1	Pin Assignment	6
3.2	Pin Definitions and Functions	6
4	General Product Characteristics	8
4.1	Absolute Maximum Ratings	8
4.2	Functional Range	9
4.3	Thermal Resistance	9
5	Electrical Characteristics	10
5.1	General Parameters	10
5.2	Power Supply Monitoring	11
6	Enable, Dimming Function and Thermal Protection	12
6.1	Description	12
6.2	Electrical Characteristics Enable, Bias, Dimming Function and Thermal Protection	13
6.2.1	PWM Dimming with μC connected to ILD4071 PWMI pin	14
6.2.2	Internal PWM dimming Function	15
6.3	Overtemperature Protection of the Device	16
7	Open Load Diagnosis	17
7.1	Description	17
7.2	Electrical Characteristics: Open Load Diagnosis	17
7.3	Open Load Diagnosis	18
8	Application Information	19
8.1	Output Peak Current Adjustment via R_{SET}	19
8.2	Switching Frequency Determination	20
8.3	ILD4071 in LED Application	22
9	Package Outlines	23
10	Revision History	24



1 Overview

- Constant Current Generation
- Wide Input Voltage Range from 5V to 40V
- Peak Current Regulation
- Very low current consumption (<2uA) in Sleep Mode
- Integrated power transistor with low saturation voltage
- Integrated fast freewheeling diode
- Integrated load current sense resistor
- Integrated status pull down transistor
- Overtemperature Protection
- Switching frequency (typ. 200kHz) adjustable via external RC network
- External PWM Dimming Input
- Integrated PWM Dimming Engine
- Analog Dimming (output current adjustable via external low power resistor and possibility to connect PTC resistor for LED protection during overtemperature conditions)
- Stable switching frequency due to fix OFF-time concept with V_{REC} (supply voltage) feedforward
- Under- and Overvoltage shutdown with hysteresis
- Small thermally enhanced exposed heatslug SMD package
- Green Product (RoHS) Compliant

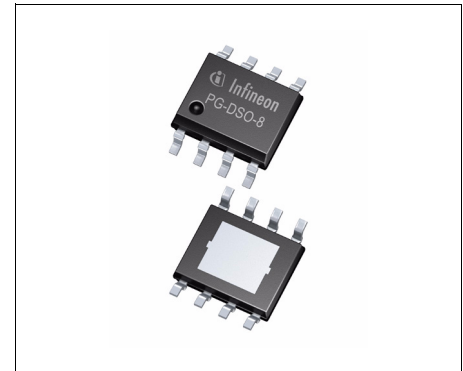

PG-DSO-8 EP

Description

The ILD4071 is a highly integrated smart LED buck controller with built in protection functions. The main function of this device is to drive single or multiple series connected LEDs efficiently from a voltage source higher than the LED forward voltage by regulating a constant LED current. The constant current regulation is especially beneficial for LED color accuracy and long LED lifetime. The built in freewheeling diode and switching transistor with current sense requires less external components and saves system costs. High flexibility is achieved by placing low power resistors to adjust output currents up to 700mA and the regulator switching frequency (typ. 200kHz). An integrated PWM dimming engine provides a LED dimming function by placing a simple RC network to GND. This feature is dedicated for simple decentralized light modules without micro controller involvement.

Type	Package	Marking
ILD4071	PG-DSO-8 EP	ILD4071

Applications

- LED Controller for Industrial Applications
- Universal Constant Current and Voltage Source
- General Illumination e.g. Halogen Replacement
- Residential Architectural and Industrial Commercial Lighting for in- and outdoor
- Signal and Marker Lights for Orientation or Navigation (e.g. steps, exit ways, etc.)

For automotive and transportation applications, please refer to the Infineon® Auto LED products.

2 Block Diagram

The ILD4071 regulates the LED current by monitoring the load current (Peak Current Measurement) through the internal switch cycle by cycle. When the current through the switch reaches the threshold I_{peak} the switch is shut-OFF and it is kept OFF for a time equal to t_{OFF} . Both I_{peak} and t_{OFF} can be fixed through few external components. The peak current I_{peak} is fixed by a resistor connected to the SET pin while the t_{OFF} is fixed by RC network. As t_{OFF} is fixed and the duty cycle depends on V_{REC} , the frequency depends on V_{REC} as well. Refer to [Chapter 8.2](#) for the evaluation of the switching frequency.

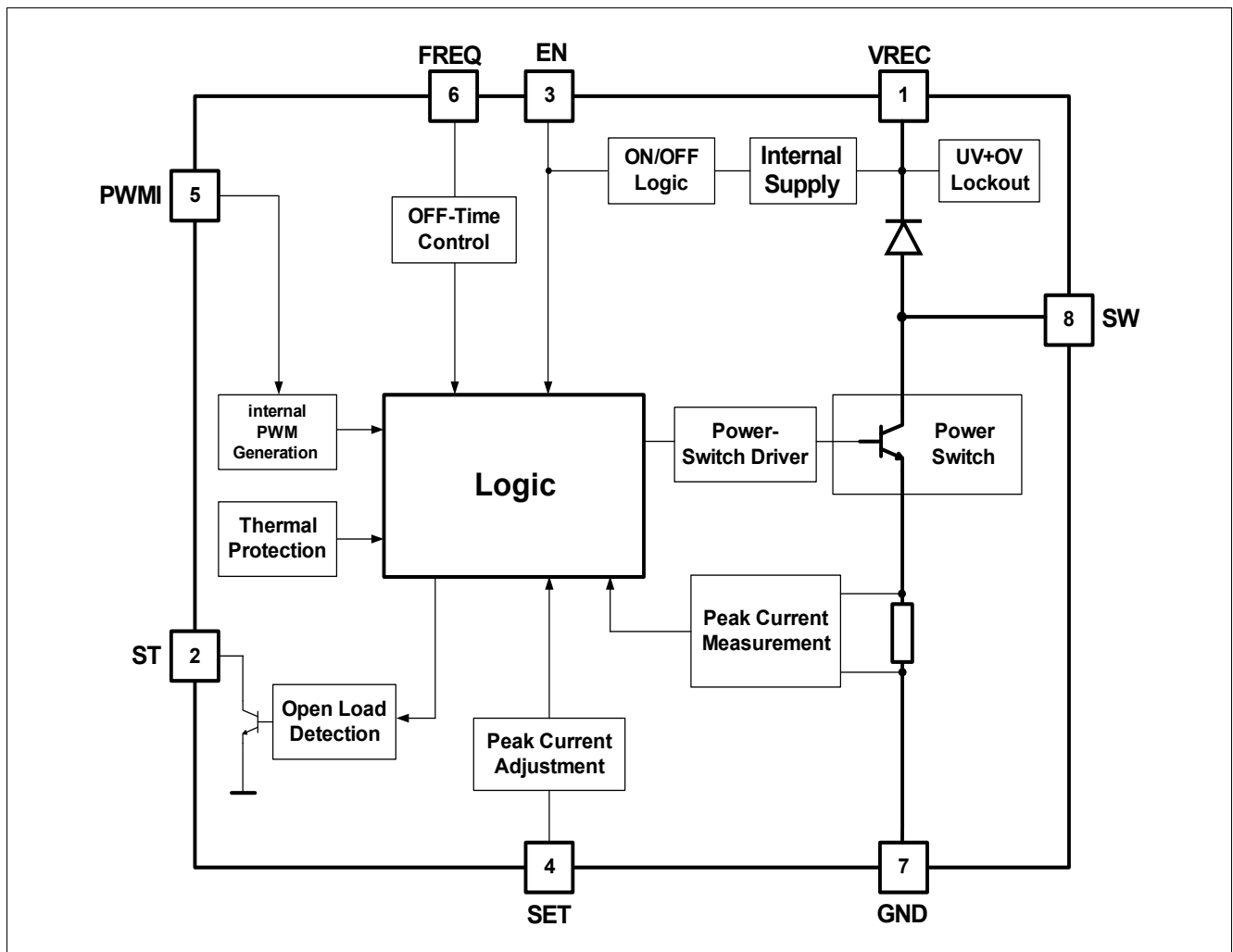

Figure 1 Block Diagram ILD4071

3 Pin Configuration

3.1 Pin Assignment

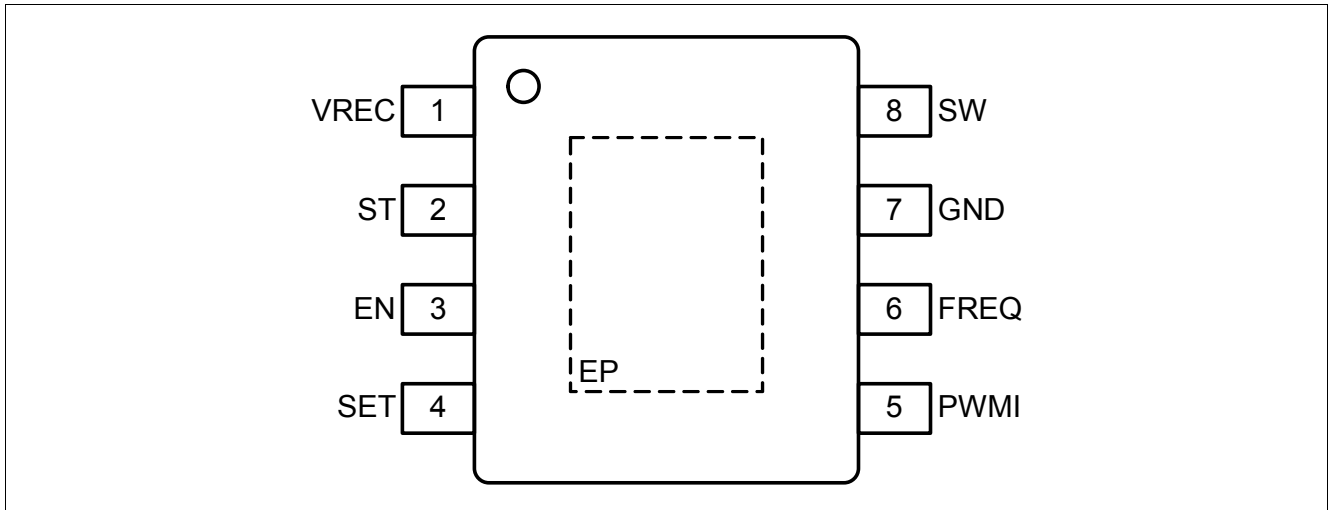

Figure 2 Pin Configuration ILD4071

3.2 Pin Definitions and Functions

Pin	Symbol	Function
1	VREC	Voltage Recirculation Output and Internal Supply Input; This pin is the supply pin of the IC (see block diagram). Furthermore the cathode of the integrated fast freewheeling diode is connected to this pin as well.
2	ST	Status Output; Open collector diagnostic output to indicate an open load failure. Refer to Chapter 7 for more details.
3	EN	Enable; Apply logic HIGH signal to enable the device
4	SET	SET Input; Connect a low power resistor to adjust the output current.
5	PWMI	PWM Input; PWM signal for dimming LEDs. Connect external R and C combination to achieve an auto PWM-dimming function with defined frequency and duty cycle. 1) internal PWM dimming function (external RC connected to GND) 2) external PWM dimming function (μC is controlling this pin) Refer to Chapter 6 for more details.
6	FREQ	FREQuency Select Input; Connect external Resistor and Capacitor to GND to set the OFF-time of the switching frequency.
7	GND	Ground; Connect to system ground.

Pin Configuration

Pin	Symbol	Function
8	SW	Integrated Power-Switch Output; Collector of the integrated NPN-power transistor.
EP		Exposed Pad; Connect to external heatspreading copper area with electrically GND (e.g. inner GND layer of the PCB via thermal vias)

4 General Product Characteristics

4.1 Absolute Maximum Ratings

Absolute Maximum Ratings¹⁾

$T_j = -40\text{ °C}$ to $+125\text{ °C}$; all voltages with respect to ground (unless otherwise specified)

Pos.	Parameter	Symbol	Limit Values		Unit	Conditions
			Min.	Max.		
Voltages						
4.1.1	VREC (Pin 1) Recirculation and Supply Input	V_{REC}	-0.3	45	V	–
4.1.2	ST (Pin 2) Diagnostic Status Output Voltage	V_{ST}	-0.3	45	V	–
4.1.3	ST (Pin 2) Diagnostic Status Current	I_{ST}	–	150	mA	–
4.1.4	EN (Pin 3) Enable Input Voltage	V_{EN}	-0.3	45	V	–
4.1.5	SET (Pin 4) Peak Current Adjust Input Voltage	V_{SET}	-0.3	6	V	–
4.1.6	PWMI (Pin 5) PWM Input Voltage	V_{PWMI}	-0.3	6	V	–
4.1.7	FREQ (Pin 6) OFF-time Adjustment Input	V_{FREQ}	-0.3	6	V	–
4.1.8	SW (Pin 8) Switch Output	V_{SW}	-0.3	45	V	–
Temperatures						
4.1.9	Junction Temperature	T_j	-40	150	°C	–
4.1.10	Storage Temperature	T_{stg}	-55	150	°C	–
ESD Susceptibility						
4.1.11	ESD Resistivity all Pins to GND	$V_{ESD,HBM}$	-2	2	kV	HBM ²⁾

1) Not subject to production test, specified by design.

2) ESD susceptibility HBM according to EIA/JESD 22-A 114B

Note: Stresses above the ones listed here may cause permanent damage to the device. Exposure to absolute maximum rating conditions for extended periods may affect device reliability.

Note: Integrated protection functions are designed to prevent IC destruction under fault conditions described in the data sheet. Fault conditions are considered as "outside" normal operating range. Protection functions are not designed for continuous repetitive operation.

4.2 Functional Range

Pos.	Parameter	Symbol	Limit Values		Unit	Conditions
			Min.	Max.		
4.2.1	Supply Voltage Range	V_{REC}	5	40 ¹⁾		–
4.2.2	Output current range	I_{OUT}	100	700	mA	–
4.2.3	Switching Frequency	f_{SW}	50	300 ¹⁾	kHz	$T_j = 25^\circ\text{C to } 150^\circ\text{C}$
4.2.4	Junction Temperature	T_j	-40	125	°C	–

1) Not subject to production test, specified by design.

Note: Within the functional range the IC operates as described in the circuit description. The electrical characteristics are specified within the conditions given in the related electrical characteristics table.

4.3 Thermal Resistance

Note: This thermal data was generated in accordance with JEDEC JESD51 standards.

For more information, go to www.jedec.org.

Pos.	Parameter	Symbol	Limit Values			Unit	Conditions
			Min.	Typ.	Max.		
4.3.1	Junction to Case	$R_{thJ-case}$	–	10	–	K/W	1) 2)
4.3.2	Junction to Ambient (2s2p)	R_{thJA}	–	40	–	K/W	1) 3)

1) Not subject to production test, specified by design.

2) Specified $R_{thJ-case}$ value is simulated at natural convection on a cold plate setup (all pins and the exposed Pad are fixed to ambient temperature). $T_a=25^\circ\text{C}$, Power Switch and freewheeling diode are dissipating 1W.

3) Specified R_{thJA} value is according to Jedec JESD51-2,-7 at natural convection on FR4 2s2p board; The Product (Chip+Package) was simulated on a 76.2 x 114.3 x 1.5 mm board with 2 inner copper layers (2 x 70 μm Cu, 2 x 35 μm Cu). According to JESD51-5 a thermal via array under the exposed pad contacted the first inner copper layer. $T_a=25^\circ\text{C}$, Power Switch and freewheeling diode are dissipating 1W.

5 Electrical Characteristics

All parameters have been tested at 25°C, unless otherwise specified.

5.1 General Parameters

Electrical Characteristics: Buck Regulator

$V_{REC} = 24\text{ V}$, $T_j = -40\text{ °C}$ to $+125\text{ °C}$, all voltages with respect to ground (unless otherwise specified)

Pos.	Parameter	Symbol	Limit Values			Unit	Conditions
			Min.	Typ.	Max.		
5.1.1	Voltage Drop over Power Transistor	$V_{Drop,100}$	–	0.8	–	V	$I_{peak}=100\text{mA}$
5.1.2	Voltage Drop over Power Transistor	$V_{Drop,700}$	–	1.4	–	V	$I_{peak}=700\text{mA}$
5.1.3	Freewheeling diode forward voltage	$V_{fw,100}$	–	0.8	–	V	$I_{peak}=100\text{mA}$
5.1.4	Freewheeling diode forward voltage	$V_{fw,700}$	–	1.4	–	V	$I_{peak}=700\text{mA}$
5.1.5	Peak over current limit	I_{peak_lim}	–	1.4	–	A	–
5.1.6	Peak current accuracy	I_{peak_acc}	450	500	550	mA	$V_{REC} = 12\text{V}$ $V_{EN} = 5\text{V}$ $V_{LED} = 7.2\text{V}$ $R_{SET} = 14\text{k}\Omega$ $L_{SW} = 220\mu\text{H}$ $f_{SW} = 200\text{kHz}$
5.1.7	Input under voltage shutdown threshold	$V_{REC,UVOFF}$	–	–	5	V	$V_{EN} = 5\text{V}$ V_{REC} decreasing; see Figure 3
5.1.8	Input voltage startup threshold	$V_{REC,UVON}$	–	–	6	V	$V_{EN} = 5\text{V}$ V_{REC} increasing; see Figure 3
5.1.9	Input over voltage shutdown threshold	$V_{REC,OVOFF}$	40.5	–	–	V	$V_{EN} = 5\text{V}$ V_{REC} increasing; see Figure 3
5.1.10	Input over voltage startup threshold	$V_{REC,OV}$	40	–	–	V	$V_{EN} = 5\text{V}$ V_{REC} decreasing; see Figure 3
5.1.11	Switch ON delay	t_{dON}	–	400	600	ns	¹⁾ –
5.1.12	Switch OFF delay	t_{dOFF}	–	500	850	ns	¹⁾ –
5.1.13	Reference Voltage at SET pin	V_{SET}	1.16	1.225	1.29	V	–
5.1.14	Pull up current for FREQ pin	I_{FREQ}	5	–	–	mA	$V_{FREQ}=0\text{V}$
5.1.15	Oscillator switch off threshold	$V_{FREQ,HIGH}$	–	3.2	–	V	–
5.1.16	Oscillator switch on threshold	$V_{FREQ,LOW}$	–	1.2	–	V	–

1) The minimum switching ON time t_{ON} must be greater than $t_{dON} + t_{dOFF}$

5.2 Power Supply Monitoring

Over- and Undervoltage shutdown

If the supply voltage V_{REC} drops below the Input under voltage threshold voltage $V_{REC,UVOFF}$, the power stage is switched OFF and the device is in normal consumption mode ($I_{q,ON}$).

If V_{REC} rises again and reaches the Input under voltage startup threshold $V_{REC,UVON}$ the power stage is restarted and the device is back to normal operation mode.

Same behavior applies to overvoltage.

The internal status transistor is switching off during an overvoltage or undervoltage event on V_{REC} .

A detailed description of the under- and overvoltage behavior is displayed in [Figure 3](#) below.

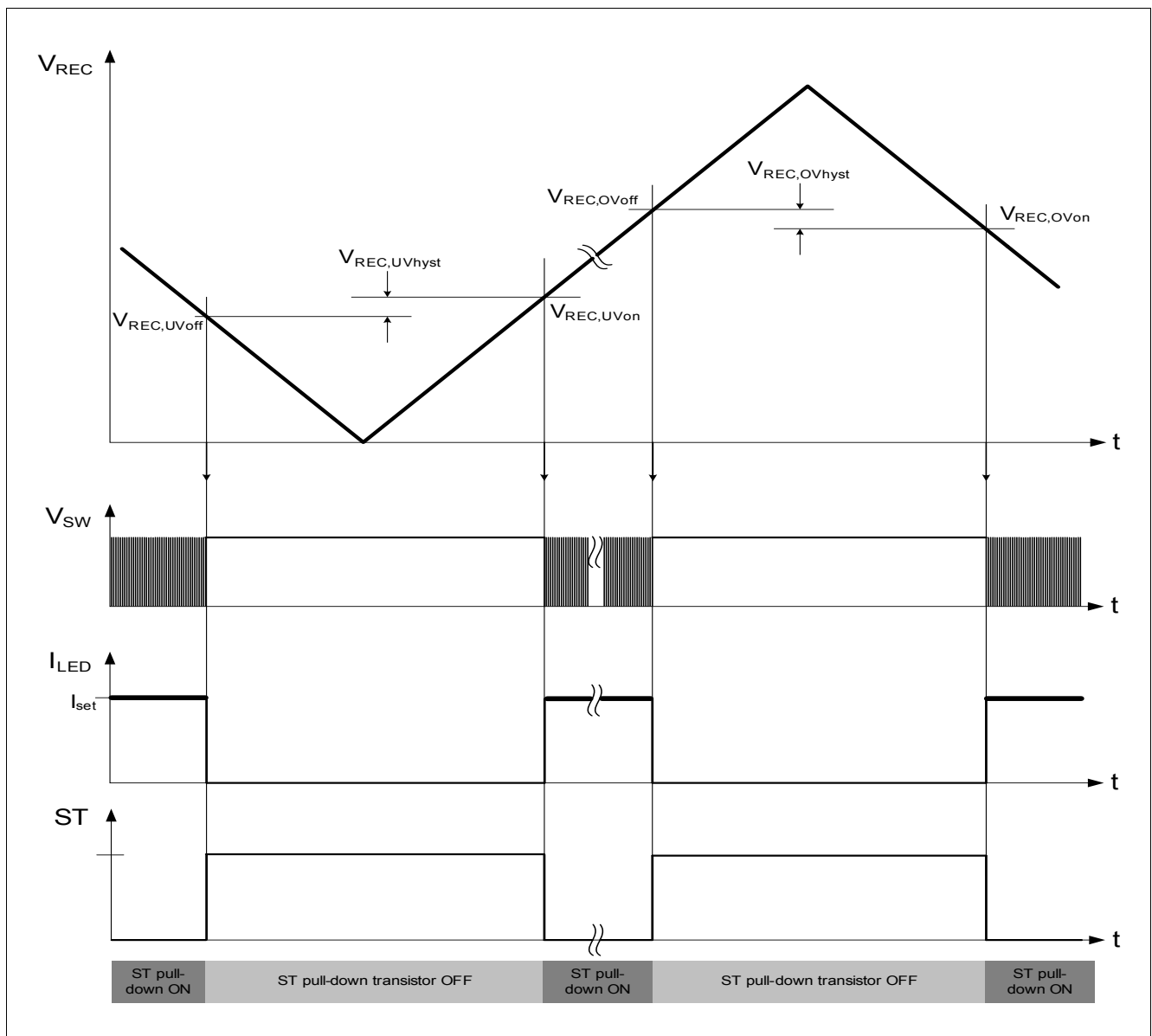

Figure 3 Over- and Undervoltage Protection

6 Enable, Dimming Function and Thermal Protection

6.1 Description

Enable function:

A logic high signal on the EN pin turns the device on. A logic low signal on enable pin EN brings the device in sleep mode. The current consumption is typ. $0.1\mu\text{A}$ in this case. The EN pin has an internal pull down resistor which ensures that the IC is in sleep mode and the power stage is switched off in case the pin EN is externally not connected.

Dimming function:

The PWMI pin combines two functions:

- 1) PWM dimming via a μC (3.3V and 5V μC)
- 2) Integrated PWM dimming engine for standalone solutions in decentralized light module (frequency and duty cycle adjustable via external R,C network)

A detailed description of the PWMI pin is displayed in [Figure 4](#) below.

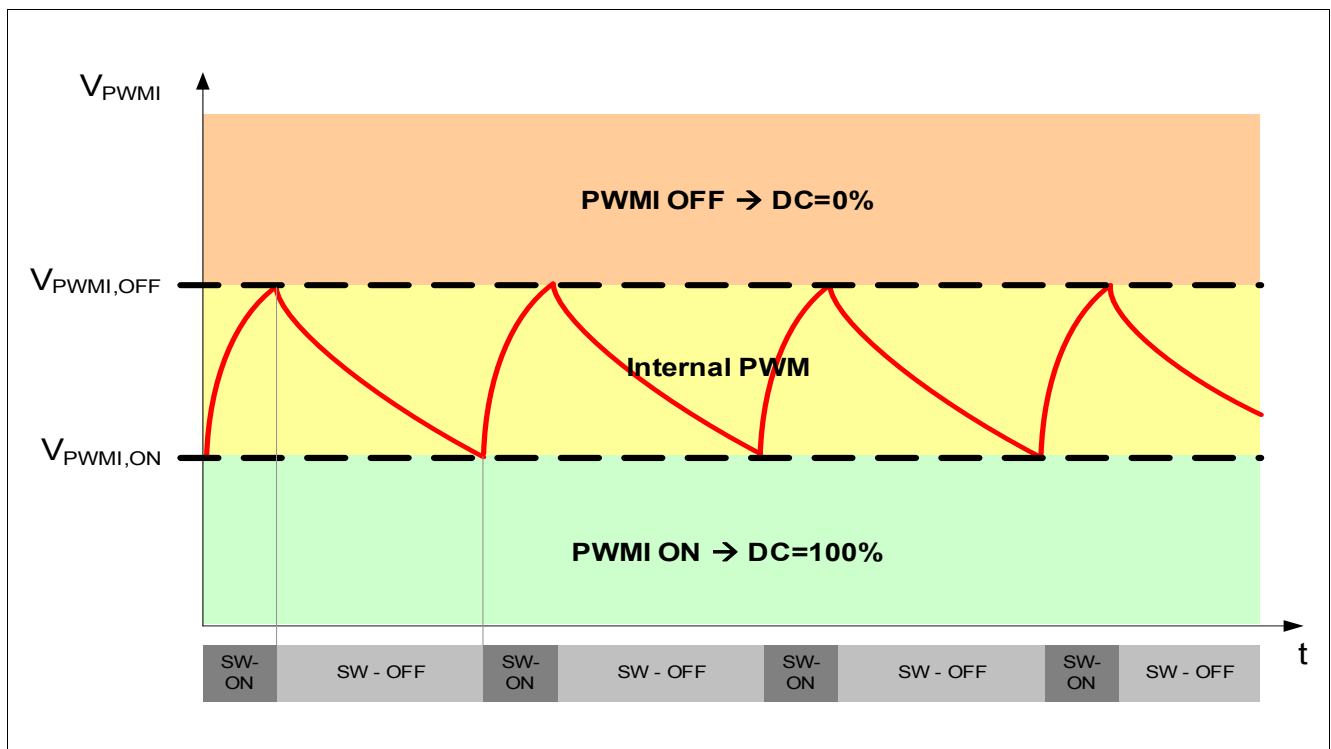

Figure 4 PWMI Pin description

6.2 Electrical Characteristics Enable, Bias, Dimming Function and Thermal Protection

All parameters have been tested at 25°C, unless otherwise specified.

Electrical Characteristics: Enable, Bias, Dimming Function and Thermal Protection

$V_{REC} = 24\text{ V}$, $T_j = -40\text{ °C}$ to $+125\text{ °C}$, all voltages with respect to ground (unless otherwise specified)

Pos.	Parameter	Symbol	Limit Values			Unit	Conditions
			Min.	Typ.	Max.		
6.2.1	Current Consumption, sleep mode	$I_{q,OFF}$	–	0.1	2	μA	$V_{EN} = 0V$;
6.2.2	Current Consumption, active mode (Open Load)	$I_{q,ON}$	–	–	5	mA	$V_{EN} = 5.0V$; $I_{peak} = 0mA$ (open load);
6.2.3	Current Consumption, active mode	$I_{q,ON}$	–	–	10	mA	$V_{EN} = 5.0V$; $I_{peak} = 700mA$
6.2.4	EN Turn On Threshold	$V_{EN,ON}$	2.8	–	–	V	–
6.2.5	EN Turn Off Threshold	$V_{EN,OFF}$	–	–	0.8	V	–
6.2.6	EN high input current	$I_{EN,hi}$	–	100	–	μA	$V_{EN} = 5V$
6.2.7	EN low input current	$I_{EN,lo}$	0	–	20	μA	$V_{EN} = 0.5V$
6.2.8	PWMI Turn On Threshold	$V_{PWMI,ON}$	–	1	–	V	see Figure 4
6.2.9	PWMI Turn Off Threshold	$V_{PWMI,OFF}$	–	2	–	V	see Figure 4
6.2.10	PWMI source current	I_{PWMI}	–	250	–	μA	$R_{set} = 10k\Omega$ $V_{PWMI} = 0.5V$;
6.2.11	Over temperature shutdown	$T_{j,sd}$	150	175	–	°C	¹⁾
6.2.12	Over temperature shutdown hysteresis	T_{j,sd_hyst}	–	15	–	K	¹⁾

1) Specified by design. Not subject to production test.

6.2.1 PWM Dimming with μC connected to ILD4071 PWMI pin

The PWMI pin can be used for PWM dimming. It is a commonly practiced dimming method to prevent color shift in LED light applications.

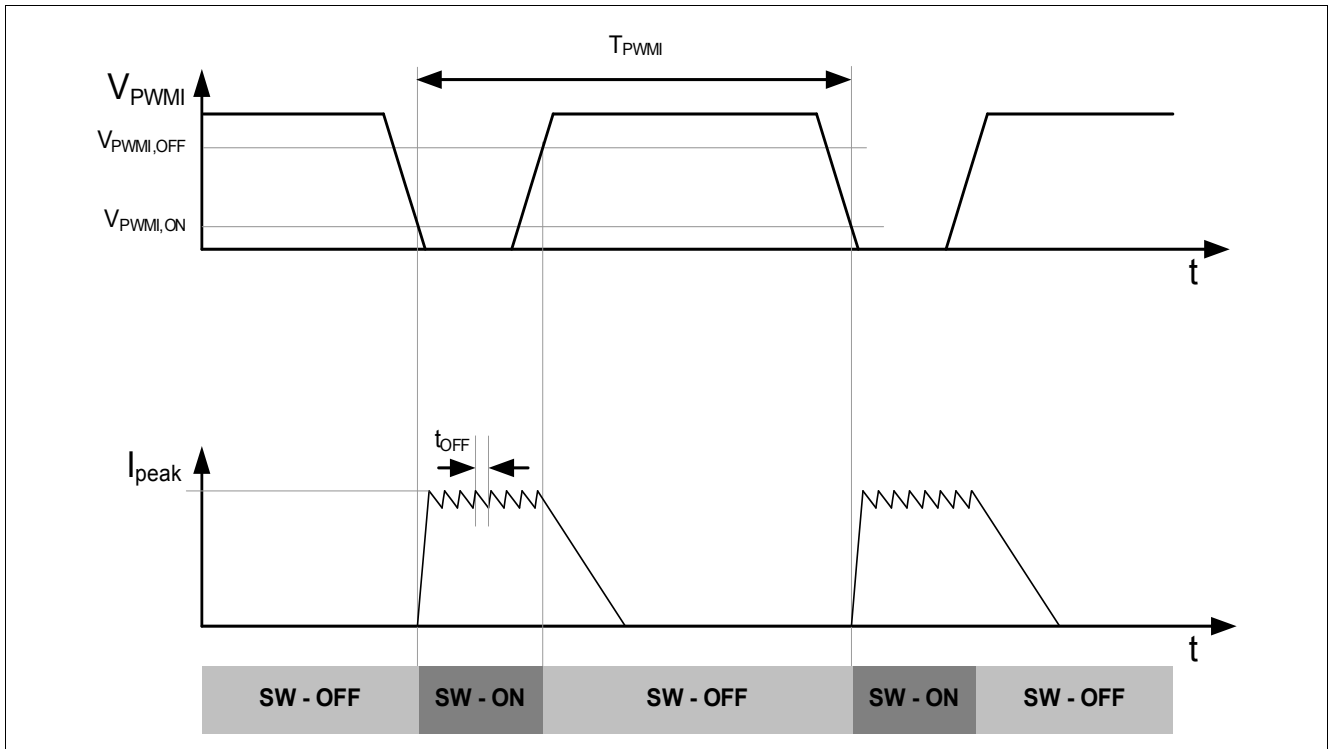

Figure 5 Timing Diagram for LED Dimming with μC

6.2.2 Internal PWM dimming Function

The **ILD4071** has an integrated PWM dimming engine. Via an external $R_{P\text{WMI}}$ and $C_{P\text{WMI}}$ network it is possible to achieve a PWM LED current waveform. The duty cycle and dimming frequency is depending on the size of the external components (see formula in **Figure 7**). This feature is specially designed to achieve a stand alone PWM dimming function without the usage of micro controllers or external logic. This allows a flexible and cost effective usage of the device in a decentralized light module application.

The advantage of a PWM dimming (to reduce the LED load current) is the change of light intensity only, at constant light color.

With an external RC network a PWM programming between 100Hz and 1200Hz and Duty Cycles between 4% and max. 20%. is possible. **Figure 6** displays the external components corresponding to the desired PWM frequency and duty cycle.

The following setup applies for the table displayed in **Figure 6**: $V_{\text{REC}}=12\text{V}$, $V_{\text{LED}}=7.2\text{V}$, $L_{\text{SW}}=220\mu\text{H}$, $R_{\text{SET}}=14\text{k}\Omega$.

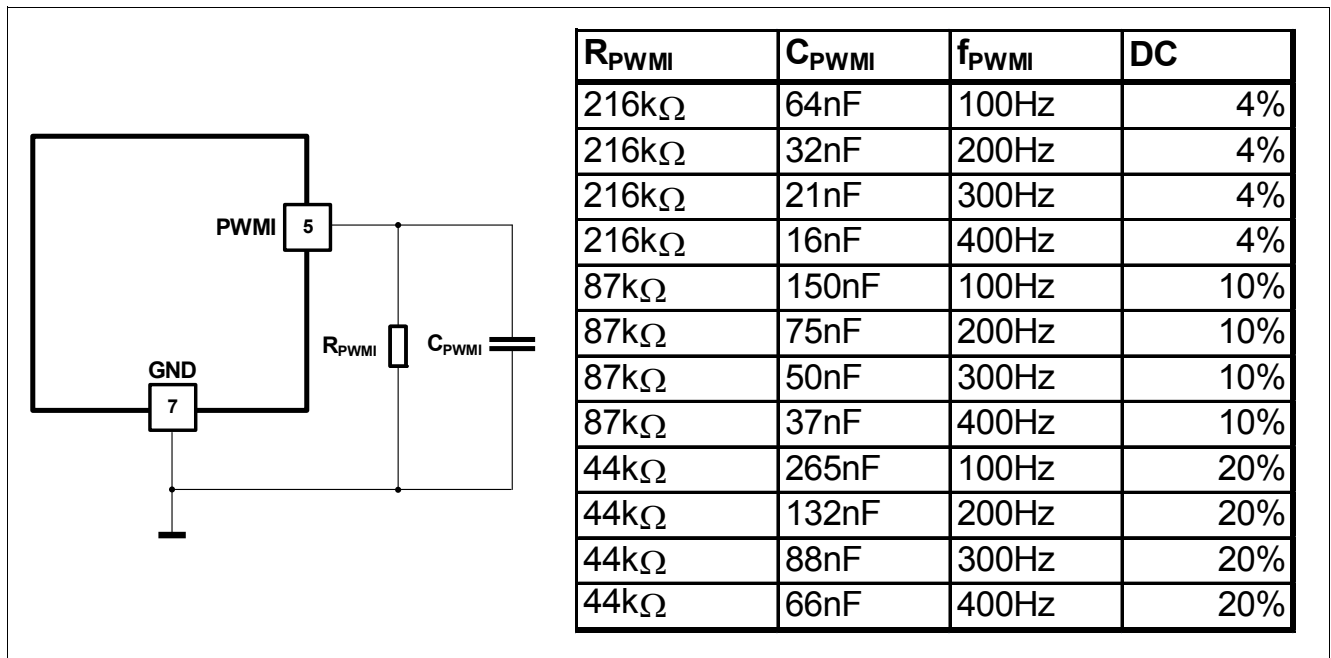

Figure 6 $R_{P\text{WMI}}$ and $C_{P\text{WMI}}$ versus $f_{P\text{WMI}}$ and DC

6.3 Overtemperature Protection of the Device

A temperature sensor at the power stage causes the overheated device to switch OFF to prevent destruction. During over temperature condition the internal ST transistor is switched OFF. Due to the autorestart function of the device the status signal will toggle accordingly. The timing of this pattern is dependant on the thermal capability of the application and can be used to distinguish between open load error and overtemperature condition. More details on the overtemperature behavior is displayed in [Figure 7](#) below.

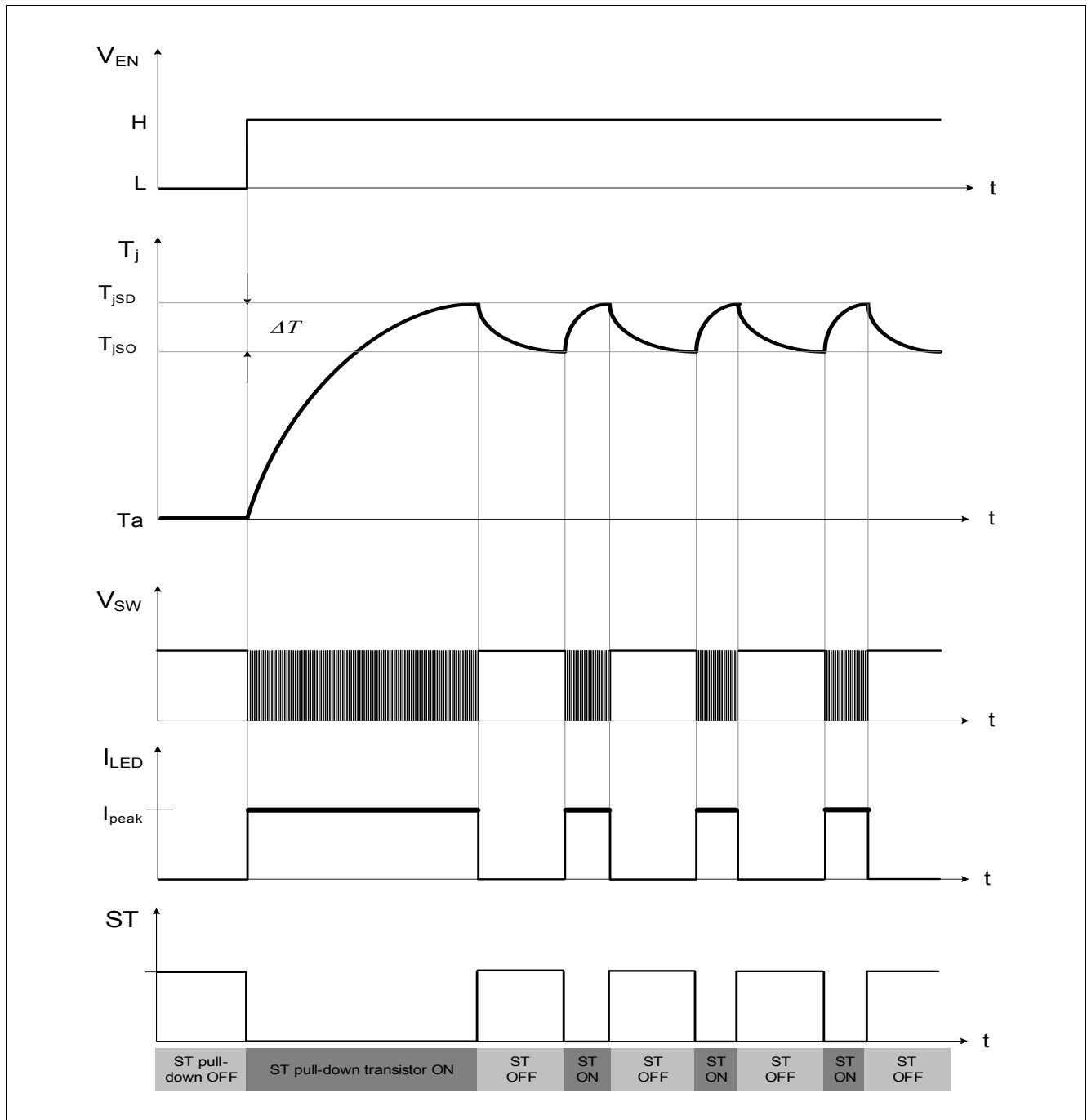

Figure 7 Overtemperature Behavior

7 Open Load Diagnosis

7.1 Description

The **ILD4071** has an integrated open load during ON diagnosis. During normal operation the ST pin (open collector output) is pulled to GND (internal transistor is ON). The open load detection is realized by monitoring the switching behavior at the SW pin. During an open load event the integrated power stage at the SW pin will be statically turned ON. If the output stage is turned ON for more than the open load diagnosis delay time (t_{OL}) an open load condition is detected. An open load event will switch OFF the internal transistor. If a μC is connected to the ST pin an external pull up resistor should be placed to achieve a logic HIGH level for the proper open load error signalling reporting. For a timing diagram on the functionality of the open load diagnosis please refer to [Figure 8](#).

7.2 Electrical Characteristics: Open Load Diagnosis

All parameters have been tested at 25°C, unless otherwise specified.

Electrical Characteristics: Open Load Diagnosis

$V_{\text{REC}} = 24 \text{ V}$, $T_j = -40 \text{ }^\circ\text{C}$ to $+125 \text{ }^\circ\text{C}$, all voltages with respect to ground (unless otherwise specified)

Pos.	Parameter	Symbol	Limit Values			Unit	Conditions
			Min.	Typ.	Max.		
7.2.1	Open Load diagnosis DelayTime	t_{OL}	20	–	–	μs	–
7.2.2	Voltage Drop over internal ST transistor	$V_{\text{Drop,ST}}$	–	0.3	–	V	$I_{\text{ST}}=150\text{mA}$

7.3 Open Load Diagnosis

The ST pin can be connected directly to a μC input. During an open load condition the ST transistor is OFF. An external pull up resistor connected to V_{DD} is required to signal a logic high signal on the ST pin during an open load error. Please consider that this diagnosis functionality is only active if the device is in active mode (HIGH potential at the EN pin).

Refer to application drawing [Figure 13](#).

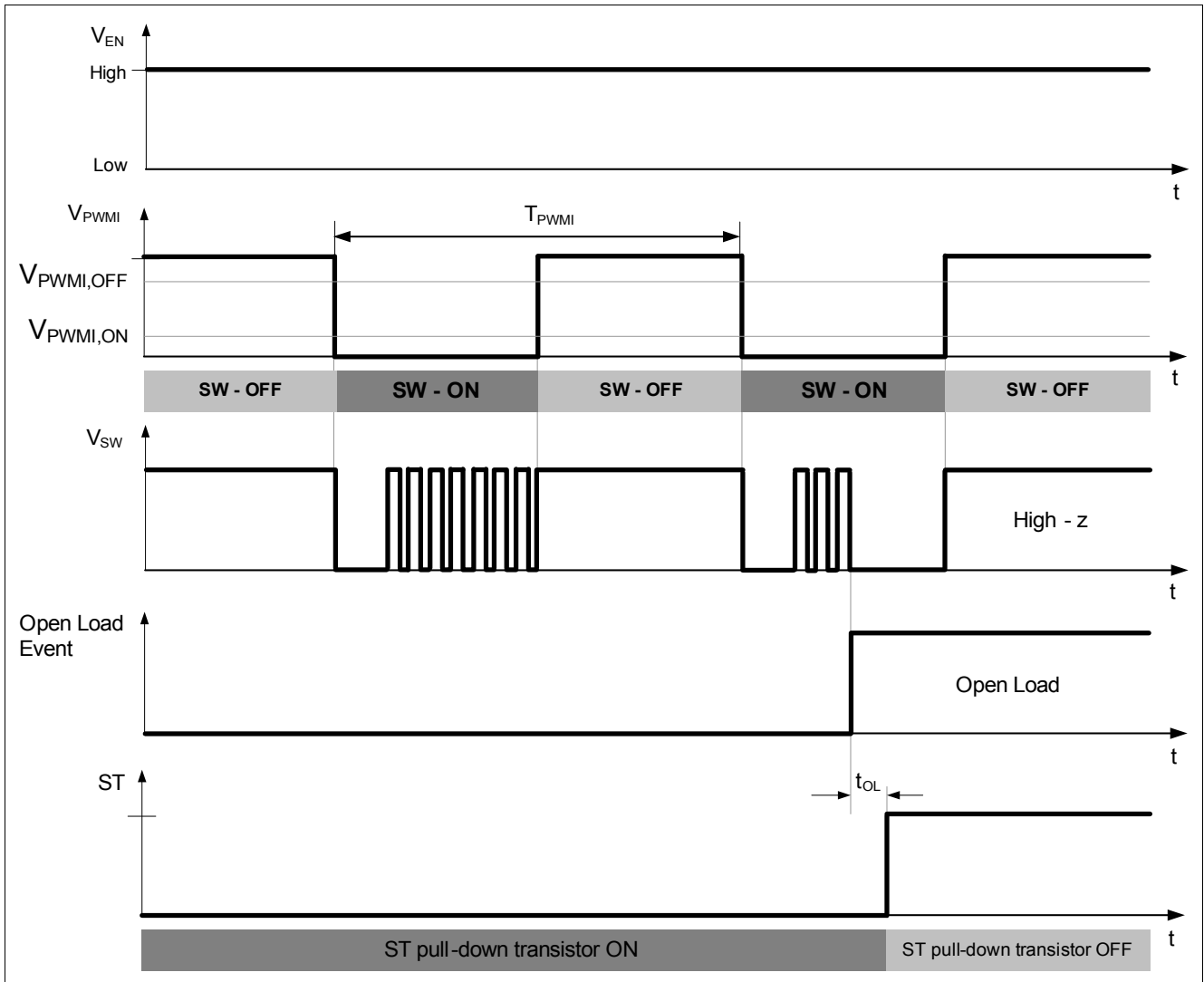

Figure 8 Open Load diagnosis via μC connected to ST pin

8 Application Information

Note: The following information is given as a hint for the implementation of the device only and shall not be regarded as a description or warranty of a certain functionality, condition or quality of the device.

8.1 Output Peak Current Adjustment via R_{SET}

The external resistor R_{SET} is used to adjust the peak current of the regulator. Maximum achievable peak current is 700mA and minimum achievable peak current is 100mA. The SET pin provides an internally fixed voltage level at typ.: 1.225V. Out of this considerations the equation is:

$$I_{peak} = (1.225V / R_{SET}) * 5710$$

The factor 5710 is derived from following considerations:

- $I_{peak, max} = 700mA$ ($R_{SET} = 10k\Omega$)
- $I_{peak, min} = 100mA$ ($R_{SET} = 70k\Omega$)

Internal comparator voltage at SET pin = 1.225V.

The circuitry behind the SET pin is adjusting higher peak currents with lower R_{SET} values.

The R_{SET} value should be in the range from 10k Ω to 70k Ω to achieve the requested peak current range.

The following setup applies for the table displayed in [Figure 9](#): $V_{REC}=12V$, $V_{LED}=7.2V$, $L_{SW}=220\mu H$.

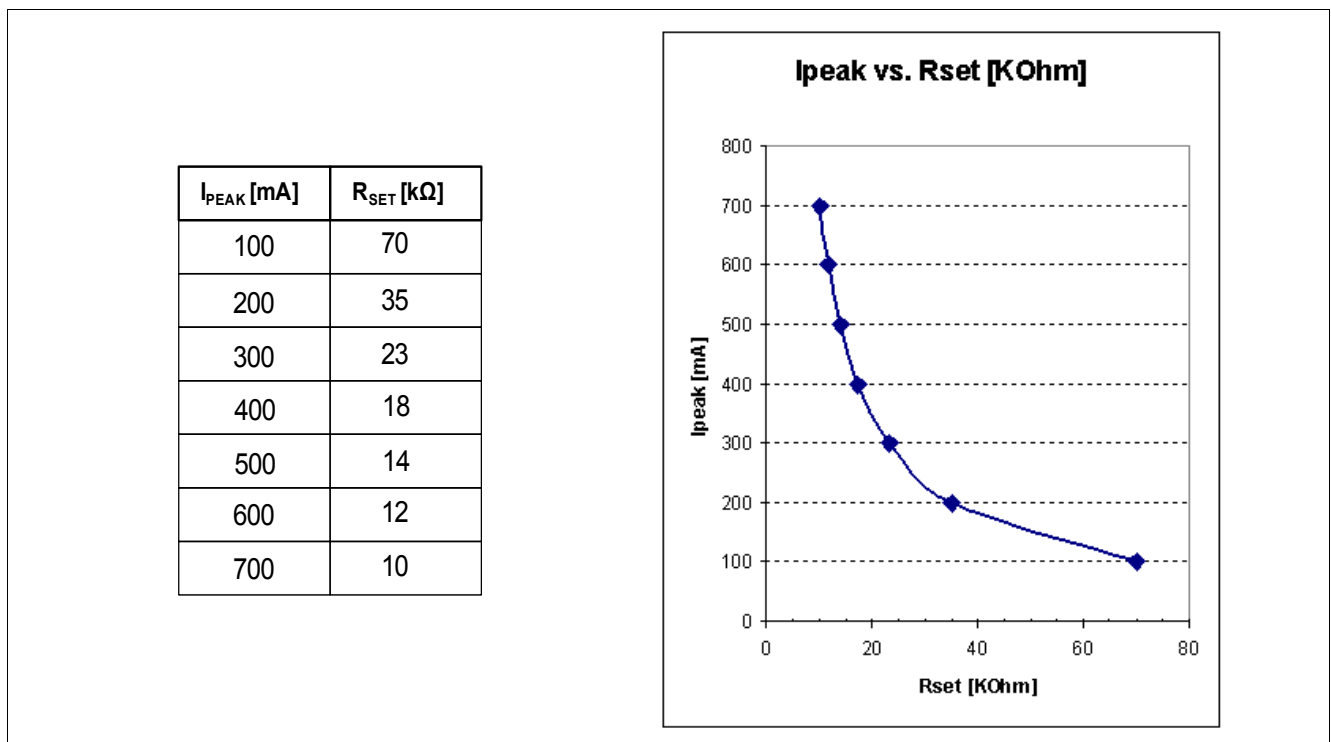

Figure 9 R_{SET} Resistor Selection

8.2 Switching Frequency Determination

The switching concept of the **ILD4071** is based on peak current regulation with constant OFF time (t_{OFF}). Thus the switching frequency f_{SW} is dependent on Input voltage (V_{REC}) variations.

With the external R_{FREQ} , C_{FREQ} , R_{COMP} , R_{CLAMP} and Z_{CLAMP} network, it is possible to adjust and stabilize the switching frequency of the regulator and achieve a.

- 1) no compensation, f_{SW} increases accordingly to the V_{REC} increase
- 2) switching frequency stabilized in a defined V_{REC} range via compensation resistor R_{COMP}
- 3) switching frequency stabilized over the whole V_{REC} range via R_{COMP} and additional clamping circuit Z_{CLAMP} and R_{CLAMP} ($=1k\Omega$)

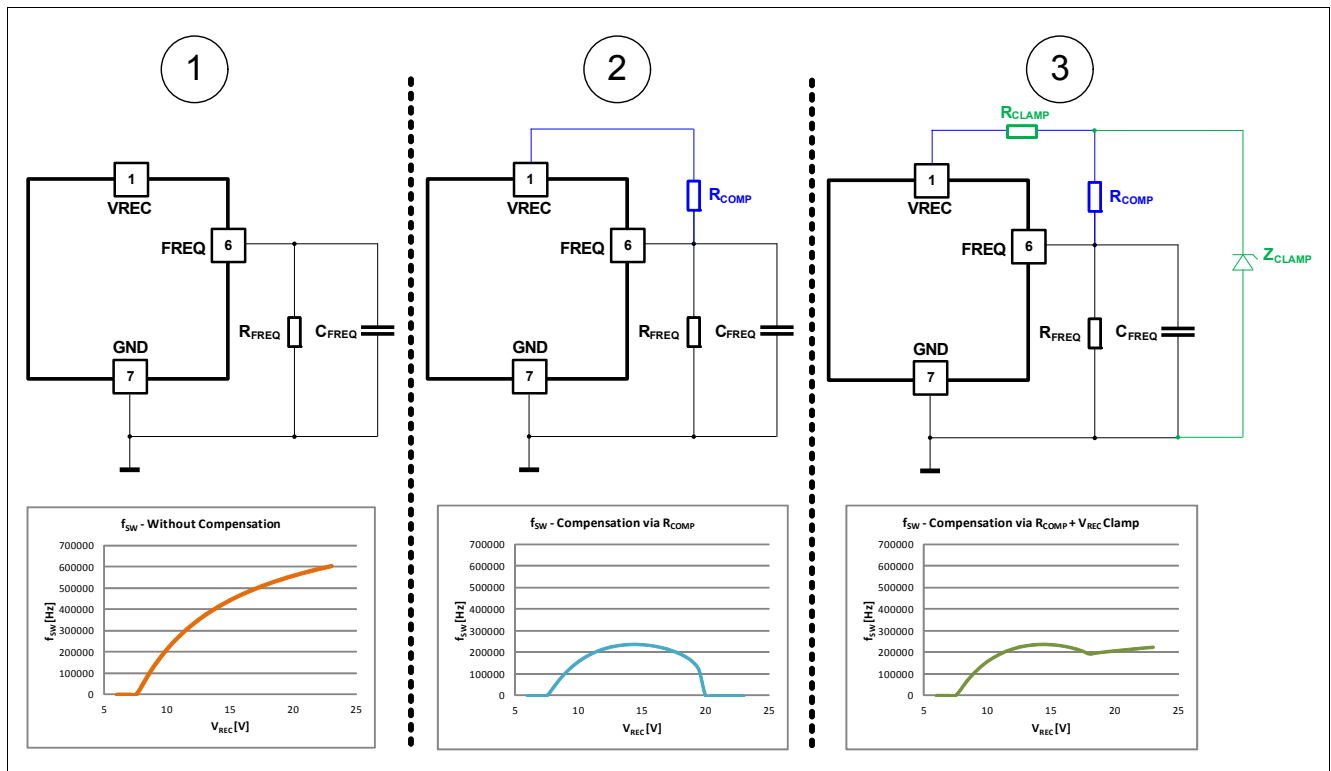

Figure 10 Setting t_{OFF} Time of Regulator with External R_{FREQ} , C_{FREQ} Network, stabilize f_{SW} via R_{COMP} , R_{CLAMP} and Z_{CLAMP}

Setup 2 applies for the table displayed in **Figure 11**: $V_{REC}=12V$, $V_{LED}=7.2V$, $L_{SW}=220\mu H$, $R_{SET}=14k\Omega$.

R_{comp}	R_{freq}	C_{freq}	f_{sw}	t_{off}
255.8k Ω	17.1k Ω	220pF	50kHz	6.47 μ s
115.8k Ω	7.7k Ω	220pF	100kHz	3.19 μ s
69.7k Ω	4.6k Ω	220pF	150kHz	2.12 μ s
46.8k Ω	3.1k Ω	220pF	200kHz	1.59 μ s
72.8k Ω	4.9k Ω	100pF	250kHz	1.27 μ s
52.7k Ω	3.5k Ω	100pF	300kHz	1.06 μ s

Figure 11 R_{FREQ} , C_{FREQ} versus f_{SW} Table

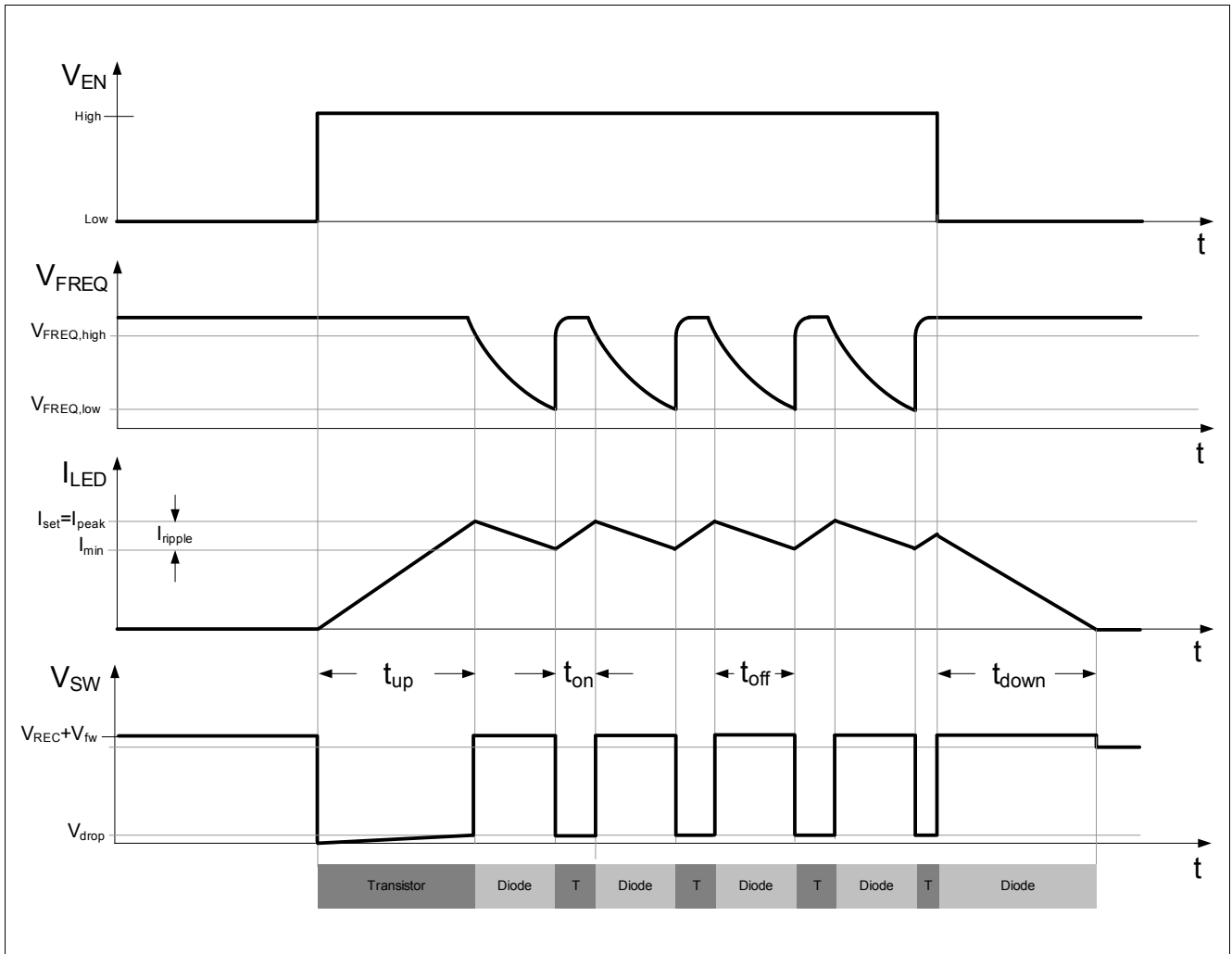

Figure 12 Theoretical Operating Waveforms

8.3 ILD4071 in LED Application

Figure 13 provides a simplified application with two high brightness LEDs in series. A μC is controlling the EN pin to put the device into sleep/active mode. Also the PWMI pin can be directly controlled via a μC port if PWM dimming of the LED current is required. The open load ST pin monitors the load condition of the application and gives feedback to the μC . An external pull up resistor is recommended to achieve a logic HIGH signal during an open load error (internal status transistor is switched OFF and the ST pin is high ohmic).

The external low power resistor R_{SET} is used to set the required peak current for the LED load (refer to **Figure 9** for more details).

To set the desired switching frequency of the buck regulator the external R_{FREQ} and C_{FREQ} network must be connected to GND (reference values are given in **Figure 11**).

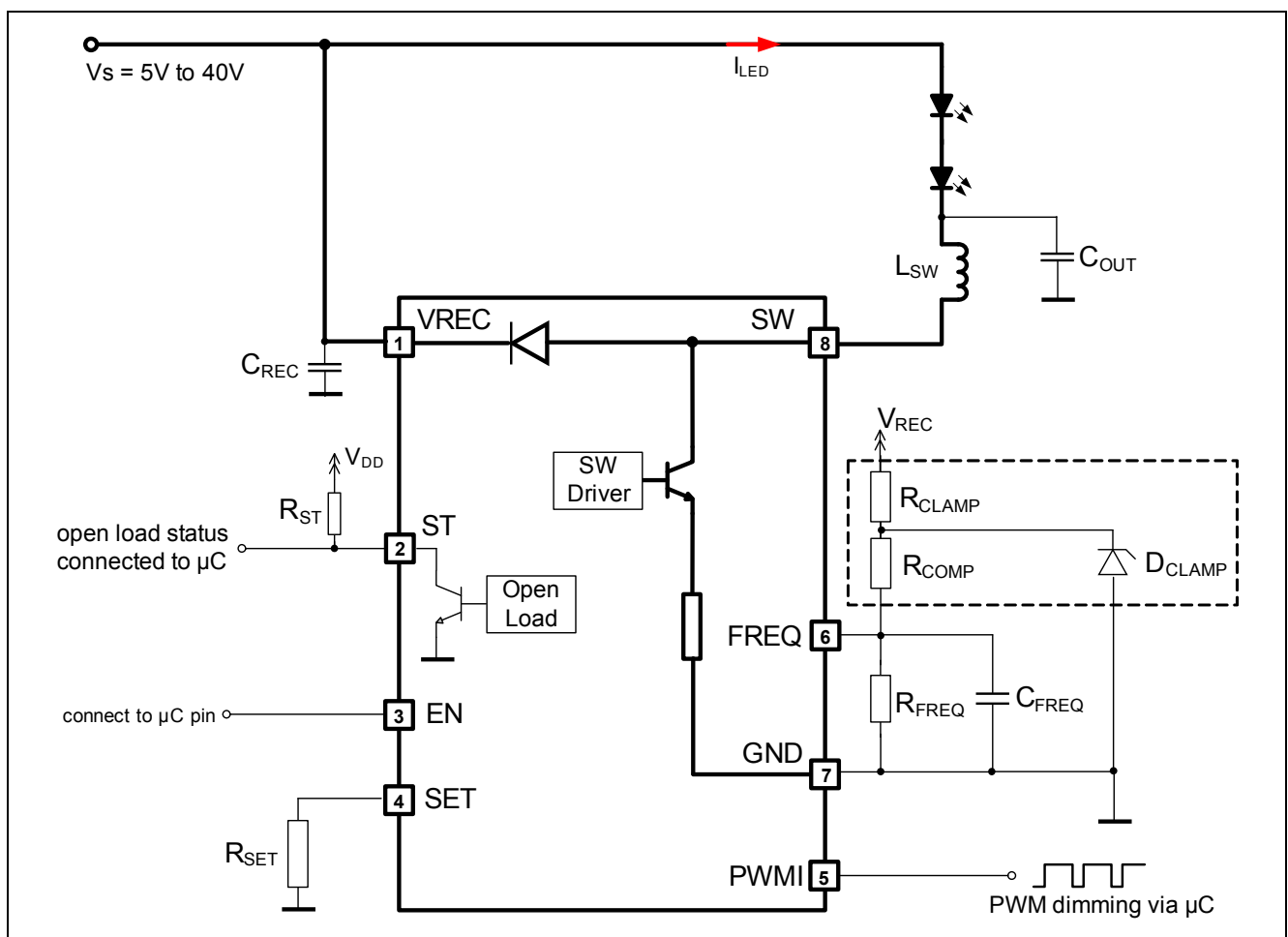

Figure 13 Simplified Application Diagram ILD4071

Note: This is a very simplified example of an application circuit. The function must be verified in the real application

9 Package Outlines

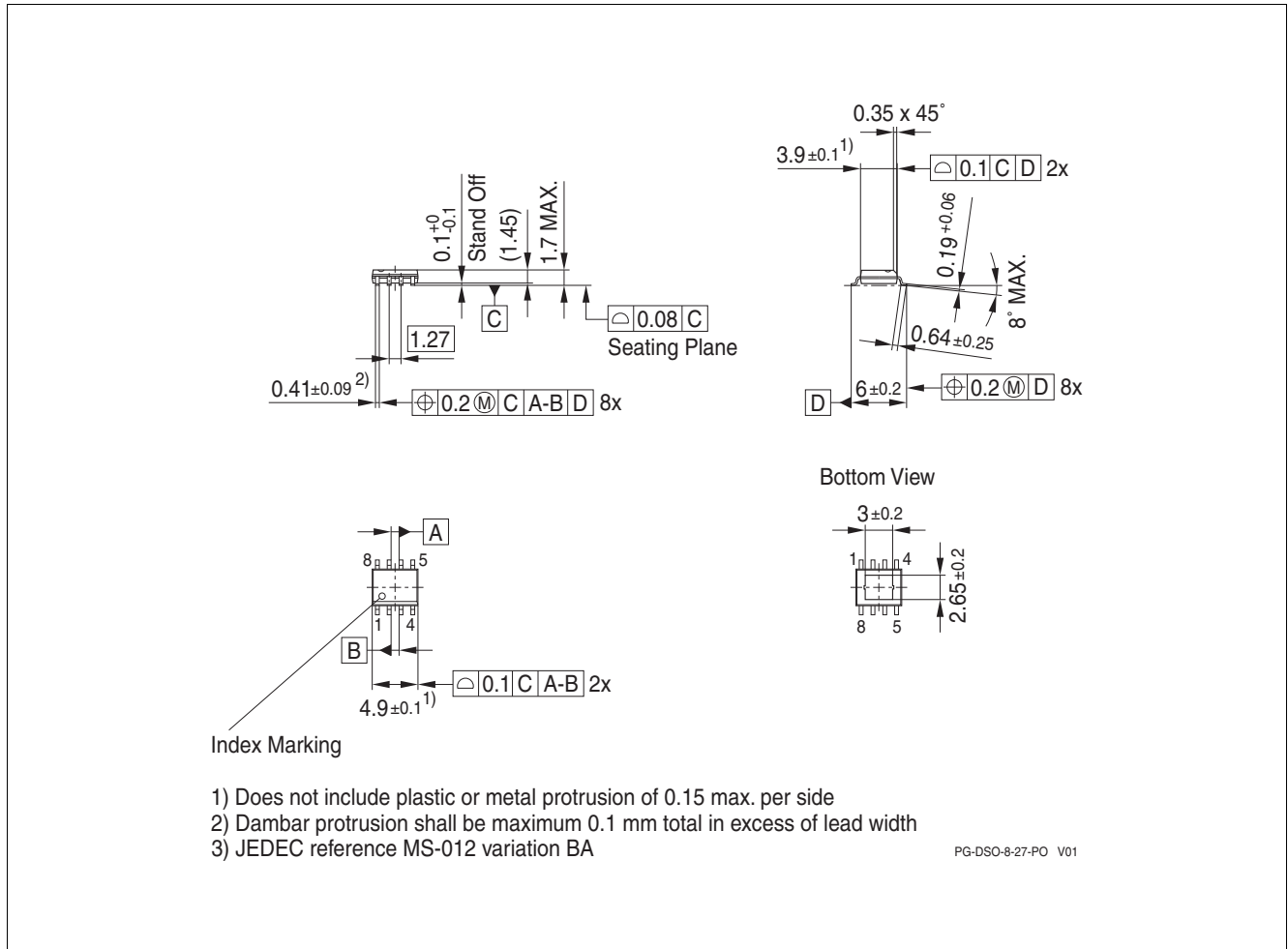

Figure 14 Outline PG-DSO-8 EP

Green Product (RoHS compliant)

To meet the world-wide customer requirements for environmentally friendly products and to be compliant with government regulations the device is available as a green product. Green products are RoHS-Compliant (i.e. Pb-free finish on leads and suitable for Pb-free soldering according to IPC/JEDEC J-STD-020).

For further package information, please visit our website:
<http://www.infineon.com/packages>.

Dimensions in mm

10 Revision History

Version	Date	Changes
Rev. 1.0	2011-11-16	Initial Data sheet for ILD4071

Edition 2011-11-16

**Published by
Infineon Technologies AG
81726 Munich, Germany**

**© 2012 Infineon Technologies AG
All Rights Reserved.**

Legal Disclaimer

The information given in this document shall in no event be regarded as a guarantee of conditions or characteristics. With respect to any examples or hints given herein, any typical values stated herein and/or any information regarding the application of the device, Infineon Technologies hereby disclaims any and all warranties and liabilities of any kind, including without limitation, warranties of non-infringement of intellectual property rights of any third party.

Information

For further information on technology, delivery terms and conditions and prices, please contact the nearest Infineon Technologies Office (www.infineon.com).

Warnings

Due to technical requirements, components may contain dangerous substances. For information on the types in question, please contact the nearest Infineon Technologies Office.

Infineon Technologies components may be used in life-support devices or systems only with the express written approval of Infineon Technologies, if a failure of such components can reasonably be expected to cause the failure of that life-support device or system or to affect the safety or effectiveness of that device or system. Life support devices or systems are intended to be implanted in the human body or to support and/or maintain and sustain and/or protect human life. If they fail, it is reasonable to assume that the health of the user or other persons may be endangered.