

## FEATURES

- Wide Input Voltage Range: 7V to 36V
- LED Output Current Up to 1.2A
- Soft-start
- Single pin on/off and brightness control using DC voltage or PWM
- High efficiency (up to 97%)
- Up to 1MHz switching frequency
- Typical 5% output current accuracy
- SOT-23, SOT-89 Lead-free Package .

## Applications

- LED/Display Back Light Driver
- Lightings
- Portable Communication Devices
- Handheld Electronics

## GENERAL DESCRIPTION

The EC4304B is a continuous mode inductive step-down converter, designed for driving single or multiple series connected LEDs efficiently from a voltage source higher than the LED voltage. The device operates from an input supply between 7V and 36V and provides an externally adjustable output current of up to 1.2A. Depending upon supply voltage and external components, this can provide up to 42 watts of output power. The EC4304B includes the output switch and a high-side output current sensing circuit, which uses an external resistor to set the nominal average output current. Output current can be adjusted above, or below the set value, by applying an external control signal to the 'ADJ' pin. The ADJ pin will accept either a DC voltage or a PWM waveform. Depending upon the control frequency, this will provide either a continuous or a gated output current. The PWM filter components are contained within the chip. The EC4304B is available in SOT-23, SOT-89 Lead-free package.

## PART NUMBER EXAMPLES

PART NO.	PACKAGE
EC4304BNB2R	SOT-23-5
EC4304BNB6R	SOT-89-5

## PIN ARRANGEMENT(Top view)

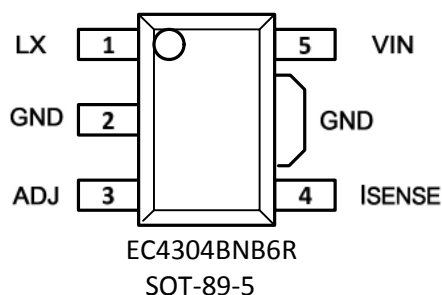
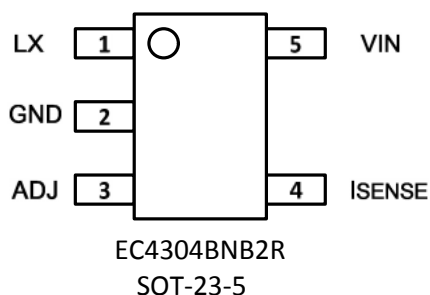



## PIN DESCRIPTION

SYMBOL	SOT-23	SOT-89	DESCRIPTION
LX	1	1	Drain of NDMOS switch
GND	2	2	Ground
ADJ	3	3	Multi-function On/Off and brightness control pin: <ul style="list-style-type: none"><li>• Leave floating for normal operation.(VADJ = VREF = 1.25V giving nominal average output current IOUTnom = 0.1/RS)</li><li>• Drive with DC voltage (0V &lt; VADJ &lt; 2.5V) to adjust output current from 0% to 200% of IOUTnom</li><li>• Drive with PWM signal from open-collector or open-drain transistor, to adjust output current. Adjustment range 0% to 100% of IOUTnom for f &gt;10kHz and 0% to 100% of IOUTnom for f &lt; 500Hz</li></ul>
ISENS	4	4	Connect resistor RS from this pin to VIN to define nominal average output current IOUTnom = 0.1/RS
VIN	5	5	Input voltage (7V to 30V). Decouple to ground with 10uF or higher X7R ceramic capacitor close to device

## ABSOLUTE MAXIMUM RATINGS

Parameter	Symbol	Value	Unit
Voltage on input pin relative to GND	VIN	-0.3 to +36	V
ISENSE pin Voltage		-5 to +0.3	V
ADJ and EN pin Voltage		-0.3 to +6	V
Operating Temperature Rang	TA	-40 to +125	C
Maximum Soldering Temperature (at leads, 10 sec)	TLEAD	300	C
Storage Temperature Rang	TS	-65 to +150	C
Power Dissipation, PD @ TA = 25°C	SOT-23	0.35	W
	SOT-89	0.5	
Package Thermal Resistance, θJA	SOT-23	250	°C/W
	SOT-89	200	



# PWM Control 1.2A Step-Down Converter

# EC4304B

## Electrical Characteristics (TA = -40 to 85°C unless otherwise noted. Typical values are at TA = 25°C, VDD = 12V)

Symbol	Description	Conditions	Min.	Typ.	Max	Unit
V <sub>IN</sub>	Input Voltage		7	-	30	V
V <sub>IRU</sub>	Internal regulator start-up threshold	V <sub>IN</sub> rising		5.65		V
V <sub>IRD</sub>	Internal regulator shutdown	V <sub>IN</sub> falling		5.55		V
I <sub>QOFF</sub>	Quiescent supply current with output off	EN pin grounded		35		uA
I <sub>QON</sub>	Quiescent supply current with output switching	ADJ pin floating f = 250kHz		1.8	5.0	mA
V <sub>SENSE</sub>	Mean current sense threshold Voltage (Defines LED current setting accuracy)	Measured on I <sub>SENSE</sub> pin with respect to V <sub>IN</sub> , V <sub>ADJ</sub> = 1.25V	95	100	105	mV
V <sub>SENTH</sub>	Sense threshold hysteresis			±15		%
I <sub>SENSE</sub>	I <sub>SENSE</sub> pin input current	V <sub>SENSE</sub> = V <sub>IN</sub> - 0.1		10		uA
V <sub>REF</sub>	Internal reference voltage	Measured on ADJ pin with pin floating		1.25		V
ΔV <sub>REF</sub> /ΔT	Temperature coefficient of V <sub>REF</sub>			50		ppm/K
V <sub>ADJ</sub>	External control voltage range on ADJ pin for DC brightness control*		0		2.5	V
V <sub>IHEN</sub>	EN Input Voltage High		2			V
V <sub>ILEN</sub>	EN Input Voltage Low				0.5	V
R <sub>ADJ</sub>	Resistance between ADJ pin and V <sub>REF</sub>	0 < V <sub>ADJ</sub> < 2.5V		200		Kohm
I <sub>LXM</sub>	Continuous LX switch current				1.2	A
R <sub>LX</sub>	LX Switch 'On' resistance	@ I <sub>LX</sub> = 1.2 A		0.3	0.45	ohm
I <sub>LXI</sub>	LX switch leakage current				5	uA
T <sub>TP</sub>	Thermal Shutdown Protect			160		C

## Electrical Characteristics (continuous)

D <sub>PWML</sub>	Duty cycle range of PWM signal applied to ADJ pin during low frequency PWM dimming mode	PWM frequency < 500Hz PWM amplitude = V <sub>REF</sub> Measured on ADJ pin	0.01		1	
	Brightness control range			100:1		
D <sub>PWMH</sub>	Duty cycle range of PWM signal applied to ADJ pin during high frequency PWM dimming mode	PWM frequency > 10KHz PWM amplitude = V <sub>REF</sub> Measured on ADJ pin	0.16		1	
	Brightness control range			5:1		
f <sub>LX</sub>	Operating frequency	ADJ pin floating, L = 33uH (0.093 ohm) I <sub>OUT</sub> = 1A @ V <sub>LED</sub> = 3.6V Driving 1 LED		280		KHz
T <sub>ONmin</sub>	Minimum switch 'ON' time	LX switch 'ON'		240**		ns
T <sub>OFFmin</sub>	Minimum switch 'OFF' time	LX switch 'OFF'		200**		ns
T <sub>ONminR</sub>	Recommended minimum switch 'ON' time	LX switch 'ON'		800		ns
f <sub>LXmax</sub>	Recommended maximum operating frequency				1	MHz
D <sub>LX</sub>	Recommended duty cycle range of output switch at f <sub>LXmax</sub>		0.3		0.7	
T <sub>PD</sub>	Internal comparator propagation delay			50		ns

**Notes :**

- \*100% brightness corresponds to  $V_{ADJ} = V_{ADJ(nom)} = V_{REF}$ . Driving the ADJ pin above  $V_{REF}$  will increase the  $V_{SENSE}$  threshold and output current proportionally.
- \*\*Parameters are not tested at production. Parameters are guaranteed by design, characterization and process control.

**Block Diagram**

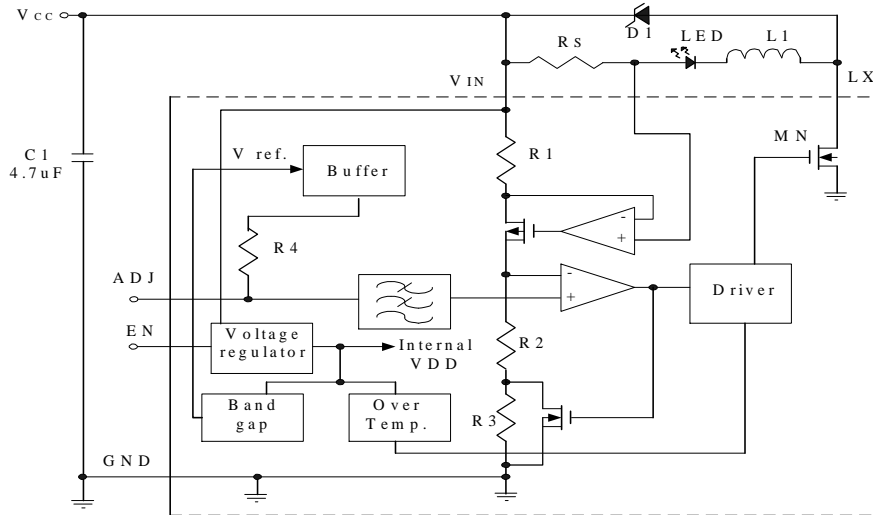

### Functional Description

The device, in conjunction with the coil (L1) and current sense resistor (RS), forms a selfoscillating continuous-mode buck converter.

### Device operation

Operation can be best understood by assuming that the ADJ pin of the device is unconnected and the voltage on this pin (V<sub>ADJ</sub>) appears directly at the (+) input of the comparator.

When input voltage V<sub>IN</sub> is first applied, the initial current in L1 and RS is zero and there is no output from the current sense circuit. Under this condition, the (-) input to the comparator is at ground and its output is high. This turns MN on and switches the LX pin low, causing current to flow from V<sub>IN</sub> to ground, via RS, L1 and the LED(s). The current rises at a rate determined by V<sub>IN</sub> and L1 to produce a voltage ramp (V<sub>SENSE</sub>) across RS. The supply referred voltage V<sub>SENSE</sub> is forced across internal resistor R1 by the current sense circuit and produces a proportional current in internal resistors R2 and R3. This produces a ground referred rising voltage at the (-) input of the comparator. When this reaches the threshold voltage (V<sub>ADJ</sub>), the comparator output switches low and MN turns off. The comparator output also drives another NMOS switch, which bypasses internal resistor R3 to provide a controlled amount of hysteresis. The hysteresis is set by R3 to be nominally 15% of V<sub>ADJ</sub>.

When MN is off, the current in L1 continues to flow via D1 and the LED(s) back to V<sub>IN</sub>. The current decays at a rate determined by the LED(s) and diode forward voltages to produce a falling voltage at the input of the comparator. When this voltage returns to V<sub>ADJ</sub>, the comparator output switches high again. This cycle of events repeats, with the comparator input ramping between limits of V<sub>ADJ</sub> ± 15%.

### Switching thresholds

With V<sub>ADJ</sub> = V<sub>REF</sub>, the ratios of R1, R2 and R3 define an average V<sub>SENSE</sub> switching threshold of 100mV (measured on the I<sub>SENSE</sub> pin with respect to V<sub>IN</sub>). The average output current I<sub>OUTnom</sub> is then defined by this voltage and RS according to:

$$I_{OUTnom} = 100mV/R_S$$

Nominal ripple current is ±15mV/R<sub>S</sub>

### Adjusting output current

The device contains a low pass filter between the ADJ pin and the threshold comparator and an internal current limiting resistor (200kohn nom) between ADJ and the internal reference voltage. This allows the ADJ pin to be overdriven with either DC or pulse signals to change the V<sub>SENSE</sub> switching threshold and adjust the output current. The filter is third order, comprising three sections, each with a cut-off frequency of nominally 4kHz. Details of the different modes of adjusting output current are given in the applications section.

### Output shutdown

The output of the low pass filter drives the shutdown circuit. When the input voltage to this circuit falls below the threshold, the internal regulator and the output switch are turned off. The voltage reference remains powered during shutdown to provide the bias current for the shutdown circuit. Quiescent supply current during shutdown is nominally 35uA and switch leakage is below 5uA.

## Applications Information

### Setting nominal average output current with external resistor $R_s$

The nominal average output current in the LED(s) is determined by the value of the external current sense resistor ( $R_s$ ) connected between  $V_{IN}$  and  $I_{SENSE}$  and is given by:

$$I_{OUTnom} = 0.1/R_s \text{ [for } R_s \geq 0.066 \text{ ohm]}$$

The table below gives values of nominal average output current for several preferred values of current setting resistor ( $R_s$ ) in the typical application circuit :

$R_s$ (ohm)	0.066	0.1	0.142	0.285
Nominal average output current (mA)	1500	1000	700	350

The above values assume that the ADJ pin is floating and at a nominal voltage of  $V_{REF}$  (=1.25V).

Note that  $R_s = 0.066\text{ohm}$  is the minimum allowed value of sense resistor under these conditions to maintain switch current below the specified maximum value.

It is possible to use different values of  $R_s$  if the ADJ pin is driven from an external voltage. (See next section)

### Output current adjustment by external DC control voltage

The ADJ pin can be driven by an external dc voltage ( $V_{ADJ}$ ), as shown, to adjust the output current to a value above or below the nominal average value defined by  $R_s$ .

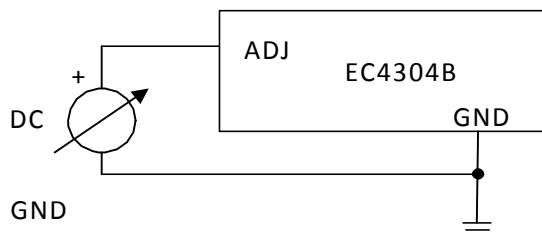

The nominal average output current in this case is given by:

$$I_{OUTdc} = (V_{ADJ} / 1.25) \times (0.1V / R_s), \text{ [for } 0 < V_{ADJ} < 2.5V]$$

Note that 100% brightness setting corresponds to  $V_{ADJ} = V_{REF}$ . When driving the ADJ pin above 1.25V,  $R_s$  must be increased in proportion to prevent  $I_{OUTdc}$  exceeding 1.5A maximum.

The input impedance of the ADJ pin is  $200\text{kohm} \pm 25\%$ .

### Output current adjustment by PWM control

#### Directly driving ADJ input

A Pulse Width Modulated (PWM) signal with duty cycle  $DPWM$  can be applied to the ADJ pin, as shown below, to adjust the output current to a value above or below the nominal average value set by resistor  $R_s$ :

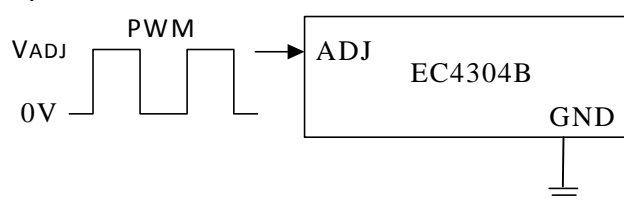

### Driving the ADJ input via open collector transistor

The recommended method of driving the ADJ pin and controlling the amplitude of the PWM waveform is to use a small NPN switching transistor as shown below:

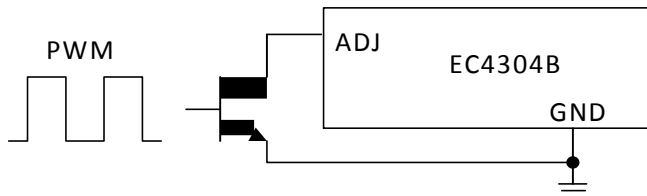

This scheme uses the 200k resistor between the ADJ pin and the internal voltage reference as a pull-up resistor for the external transistor.

### Driving the ADJ input from a microcontroller

Another possibility is to drive the device from the open drain output of a microcontroller. The diagram below shows one method of doing this:

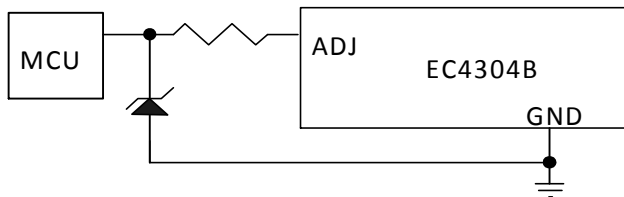

If the NMOS transistor within the microcontroller has high Drain / Source capacitance, this arrangement can inject a negative spike into ADJ input of the EC4304B and cause erratic operation but the addition of a Schottky clamp diode (cathode to ADJ) to ground and inclusion of a series resistor (10K) will prevent this. See the section on PWM dimming for more details of the various modes of control using high frequency and low frequency PWM signals.

### Shutdown mode

Taking the EN pin to a voltage below 0.8V for more than approximately 100us, will turn off the output and supply current will fall to a low standby level of 35uA nominal.

**Capacitor selection**

A low ESR capacitor should be used for input decoupling, as the ESR of this capacitor appears in series with the supply source impedance and lowers overall efficiency. This capacitor has to supply the relatively high peak current to the coil and smooth the current ripple on the input supply. A minimum value of 47uF is acceptable if the input source is close to the device, but higher values will improve performance at lower input voltages, especially when the source impedance is high. In order to avoid high frequency noise influence and improve circuit stability, it is recommended to shunt a value of 0.22uF Capacitor. The input capacitor should be placed as close as possible to the IC. For maximum stability over temperature and voltage, capacitors with X7R, X5R, or better dielectric are recommended. Capacitors with Y5V dielectric are not suitable for decoupling in this application and should not be used.

**Inductor selection**

Recommended inductor values for the EC4304B are in the range 33uH to 100uH. Higher values of inductance are recommended at higher supply voltages in order to minimize errors due to switching delays, which result in increased ripple and lower efficiency. Higher values of inductance also result in a smaller change in output current over the supply voltage range. The inductor should be mounted as close to the device as possible with low resistance connections to the LX and VIN pins. The chosen coil should have a saturation current higher than the peak output current and a continuous current rating above the required mean output current.

The inductor value should be chosen to maintain operating duty cycle and switch 'on'/'off' times within the specified limits over the supply voltage and load current range.

LX switch on time :  $t_{on} = L\Delta I / (V_{IN} - V_{LED} - I_{avg} (R_S + r_L + R_{LX}))$ , note:  $t_{onmin} > 240ns$

LX switch off time :  $t_{off} = L\Delta I / (V_{LED} + V_D + I_{avg} (R_S + r_L))$ , note:  $t_{offmin} > 200ns$

Where:

“L” is the coil inductance (H)

“ΔI” is the coil peak-peak ripple current (A) {Internally set to 0.3 x I<sub>avg</sub>}

“rL” is the coil resistance (ohm)

“RS” is the current sense resistance

“I<sub>avg</sub>” is the required LED current (A)

“V<sub>IN</sub>” is the supply voltage (V)

“V<sub>LED</sub>” is the total LED forward voltage (V)

“R<sub>LX</sub>” is the switch resistance (ohm) {=0.3 ohm nominal}

“V<sub>D</sub>” is the diode forward voltage at the required load current (V)



## TYPICAL APPLICATION CIRCUITS

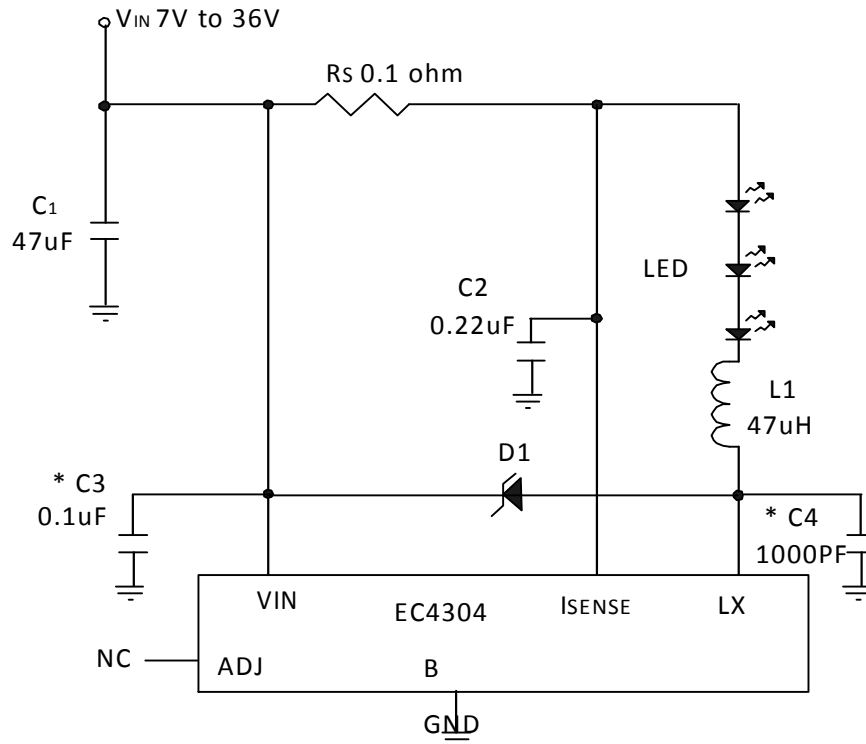

\* note : When outputs the big current, the noise are big, this and the system environment and PCB layout have the influential, may defer to the actual need to increase the capacitor filtration noise.

PACKAGE DIMENSIONS

SOT-23-5

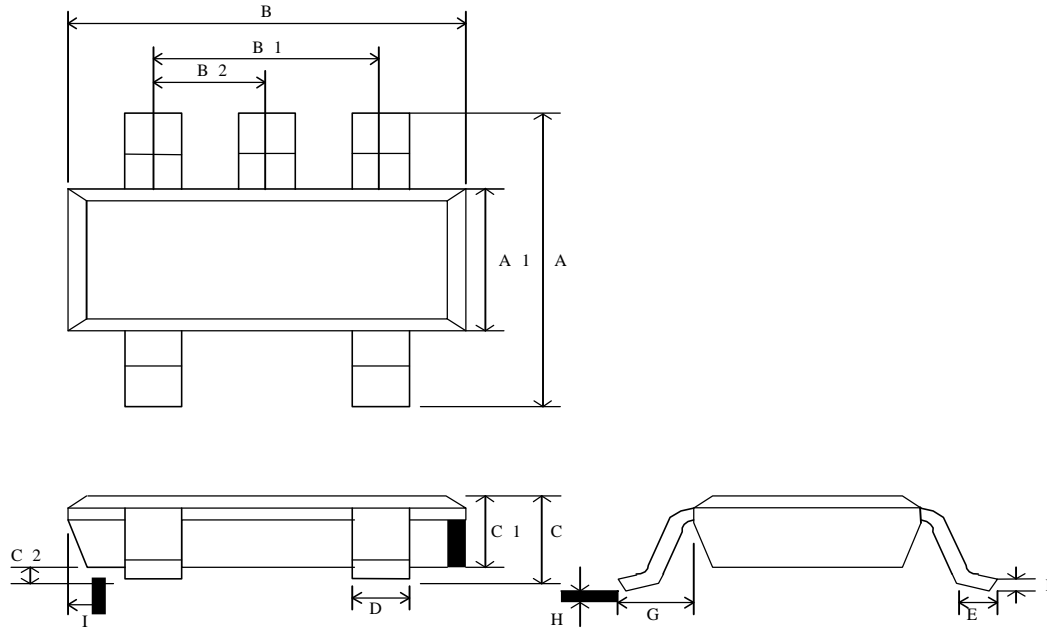

Symbol	Dimension in mm			Dimension in inch		
	Min.	Typ.	Max.	Min.	Typ.	Max.
A	2.60	2.80	3.00	0.102	0.110	0.118
A1	1.40	1.575	1.60	0.055	0.062	0.063
B	2.70	2.85	3.00	0.106	0.112	0.118
B1		1.90(BSC)			0.075(BSC)	
B2		0.95(BSC)			0.037(BSC)	
C	0.95	1.20	1.45	0.037	0.047	0.057
C1	0.90	1.10	1.30	0.035	0.043	0.051
C2	0	0.075	0.150	0	0.003	0.06
D		0.40			0.015	
E	0.30	0.45	0.60	0.012	0.018	0.023
F	0.08	0.15	0.22	0.003	0.006	0.009
G		0.60(REF)				
H					0~8°	
I		5~15°			5~15°	

**PACKAGE DIMENSIONS**

**SOT-89**

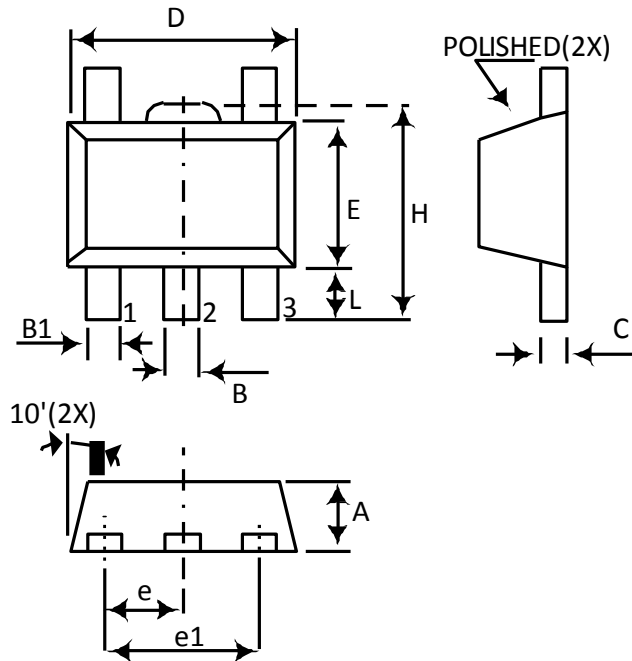

Symbol	Dimension in mm		Dimension in inch	
	Min.	Max.	Min.	Max.
A	1.40	1.60	0.055	0.063
B	0.44	0.56	0.017	0.022
B1	0.36	0.48	0.014	0.019
C	0.35	0.44	0.013	0.017
D	4.40	4.60	0.173	0.181
E	2.29	2.60	0.090	0.102
H	3.94	4.25	0.155	0.167
e	1.50 BSC		0.059 BSC	
e1	3.00 BSC		0.118 BSC	
L	0.89	1.2	0.035	0.047

**\*Note :**

The thermal pad on the IC's bottom has to be mounted on the copper foil.

To eliminate the noise influence, the thermal pad is suggested to be connected to GND on PCB. In addition, desired thermal conductivity will be improved, if a heat-conducting copper foil on PCB is soldered with thermal pad. The thermal pad enhances the power dissipation. As a result, a large amount of current can be sunk safely in one package.