

155Mbps 1x9 SC Duplex Optical Transceiver Module for Fast Ethernet, ATM, SONET/SDH STM-1/OC-3



Description :

The OPT-155Bxxxx series from DELTA are 1x9 optical transceiver modules designed expressly for high-speed communication applications that require rates of up to 155Mbps. They are all compliant with the SONET/SDH standards.

The OPT-155Bxxxx transceivers are supplied in industry standard 1x9 SIP package style with duplex SC connector.

The OPT-155Bxxxx also includes a Signal-Detect circuit that provides PECL or TTL logic output state.

The OPT-155Bxxxx transceivers are Class-1 eye safety products and effective distance depends on ITU-T G.957 standard or power penalty.

The transmitter sections utilize 1310nm Edge Emitting InGaAsP Laser Diode. This Laser Diode is packaged in the optical subassembly portion of the transmitter section. A custom silicon IC that converts differential PECL logical signals into an analog LD driving current then drive it.

The receiver sections utilize InGaAs PIN photodiodes coupled into a custom silicon transimpedance preamplifier IC. These are packaged in the optical subassembly portion of receiver.

Features :

- Full Compliance with the Optical Performance Requirements of the ATM 100Mbps and 100 Base-FX Version of IEEE 802.3u.
- Industry Standard 1x9 Footprint and Duplex SC Connector Interface.
- Single 5V (OPT-155B1xxx、OPT-155B3xxx) or 3.3V(OPT-155B2xxx、OPT-155B4xxx)Power Supply.
- PECL Differential Inputs and Outputs.
- PECL or TTL Receiver Signal Detect Indicator.
- Wave Solder and Aqueous Wash Process Compatible.

These PIN / Preamplifier combinations are coupled into a custom quantizer IC which provides the final pulse shaping for the logic output and the Signal Detect function. The data output is differential. The signal detect output is single-ended.

Application :

- Single-mode Fiber Backbone Links.
- Fast Ethernet and ATM Compatible.
- Single-mode Fiber Media Converter.

Absolute Maximum Ratings

Parameter	Symbol	Min.	Typ.	Max.	Unit	Note
Storage Temperature	T _s	-40		85	°C	
Supply Voltage	V _{CC}	0		6	V	

Recommended Operating Conditions

Parameter	Symbol	Min.	Typ.	Max.	Unit	Note
Data Rate		100	155.52	200	Mbps	
Operating Temperature						
OPT-155Bxxx	T _A	0	25	70	°C	
OPT-155BxxxT		-40	25	85		
Supply Voltage						
OPT-155B1xxxx · OPT-155B3xxxx	V _{CC}	4.75	5	5.25	V	
OPT-155B2xxxx · OPT-155B4xxxx		3.15	3.3	3.45		

Electrical Characteristics

Parameter	Symbol	Min.	Typ.	Max.	Unit	Note
Transmitter						
Transmitter Data Input Voltage-Low	V _{IL-VCC}	-1.81		-1.48	V	
Transmitter Data Input Voltage-High	V _{IH-VCC}	-1.16		-0.88	V	
Receiver						
Data Output Voltage-Low	V _{OL-VCC}	-1.95		-1.62	V	
Data Output Voltage-High	V _{OH-VCC}	-1.045		-0.74	V	
SD Output Voltage-Low	V _{SDH-VCC}	-1.95		-1.62	V	ECL Family
SD Output Voltage-High	V _{SDL-VCC}	-1.045		-0.74	V	ECL Family

Optical Characteristics

 (Data Rate = 155.52Mbps, PRBS=2²³-1, NRZ, 9/125um SMF)

Parameter	Symbol	Min.	Typ.	Max.	Unit	Note
Transmitter						
Supply Current	I _{CC}			165 145	mA	OPT-155B1 · B3 Series OPT-155B2 · B4 Series
Mean Launch Power	P _O	-20 -15 -8 -5		-15 -8 -5 0	dBm	OPT-155BxHxxx OPT-155BxJxxx OPT-155BxLxxx OPT-155BxMxxx
Optical Extinction Ratio	E.R.	9			dB	
Center Wavelength	λ _C	1280	1310	1340	nm	
Spectral Width (RMS)	σ			2	nm	
Optical Risetime / Falltime	t _r /t _f			0.7	ns	10%~90%
Output Eye Diagram	Compliant with ITU-T recommendation G.957					
Receiver						
Supply Current	I _{CC}			145 120	mA	OPT-155B1 · B3 Series OPT-155B2 · B4 Series
Sensitivity	P _{IN}			-32 -34	dBm	OPT-155BxMxxx
Overload	P _{OL}	-8			dBm	
Signal Detect-Asserted	P _A			-34	dBm	
Signal Detect-DeAsserted	P _D	-45			dBm	
Signal Detect-Hysteresis	P _A -P _D	1			dB	

 Notes : The sensitivity should be tested at BER of 1×10⁻¹⁰ or better with an input signal consisting of 155.52Mb/s, NRZ, PRBS=2²³-1 and E.R.= 9dB.

Pin Definition :

PIN	Symbol	Functional description
1	GND	Receiver Signal Ground
2	RD (+)	Receiver Data Out (LVPECL or PECL)
3	RD (-)	Receiver Data Out Bar (LVPECL or PECL)
4	SD	Receiver Signal Detect (LVPECL , PECL , LVTTTL or TTL)
5	VccR	Receiver Power Supply
6	VccT	Transmitter Power Supply
7	TD (-)	Transmitter Data In Bar (LVPECL or PECL)
8	TD (+)	Transmitter Data In (LVPECL or PECL)
9	GND	Transmitter Signal Ground

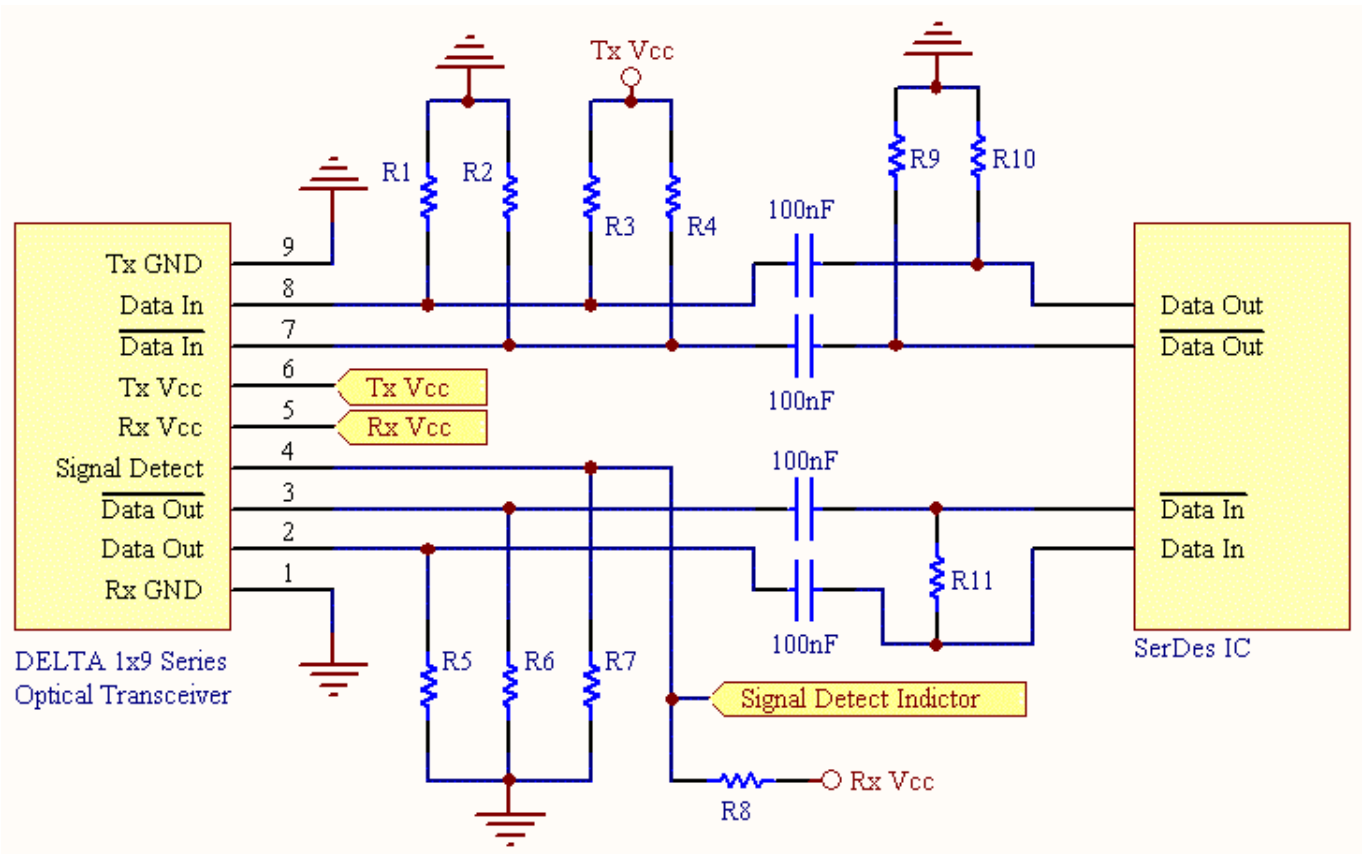
Recommend Circuit Schematic :

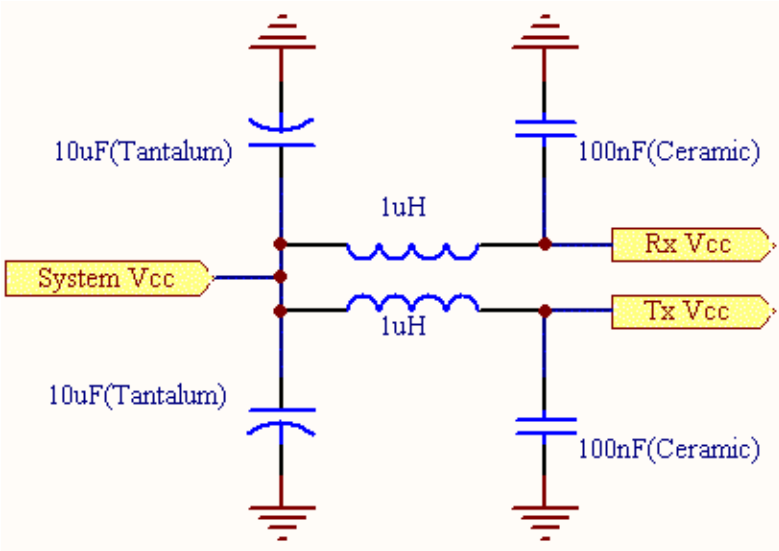

Note :

- When system Vcc is 5V, the resistors are as below:
 $R1=R2=191\Omega$; $R3=R4=68\Omega$
 $R5=R6=270\Omega$
 For PECL Level : $R7=130\Omega$; $R8=82\Omega$
 For TTL Level : $R7$ 、 $R8$, No use.
- When system Vcc is 3.3V, the resistors are as below:
 $R1=R2=130\Omega$; $R3=R4=82\Omega$
 $R5=R6=150\Omega$
 For PECL Level : $R7=82\Omega$; $R8=130\Omega$
 For TTL Level : $R7$ 、 $R8$, No use.
- $R9$, $R10$, $R11$ depend on SerDes IC specification.
- For getting better EMI performance, the Tx Vcc and Rx Vcc should isolate each other as left photograph.

Package Outline :

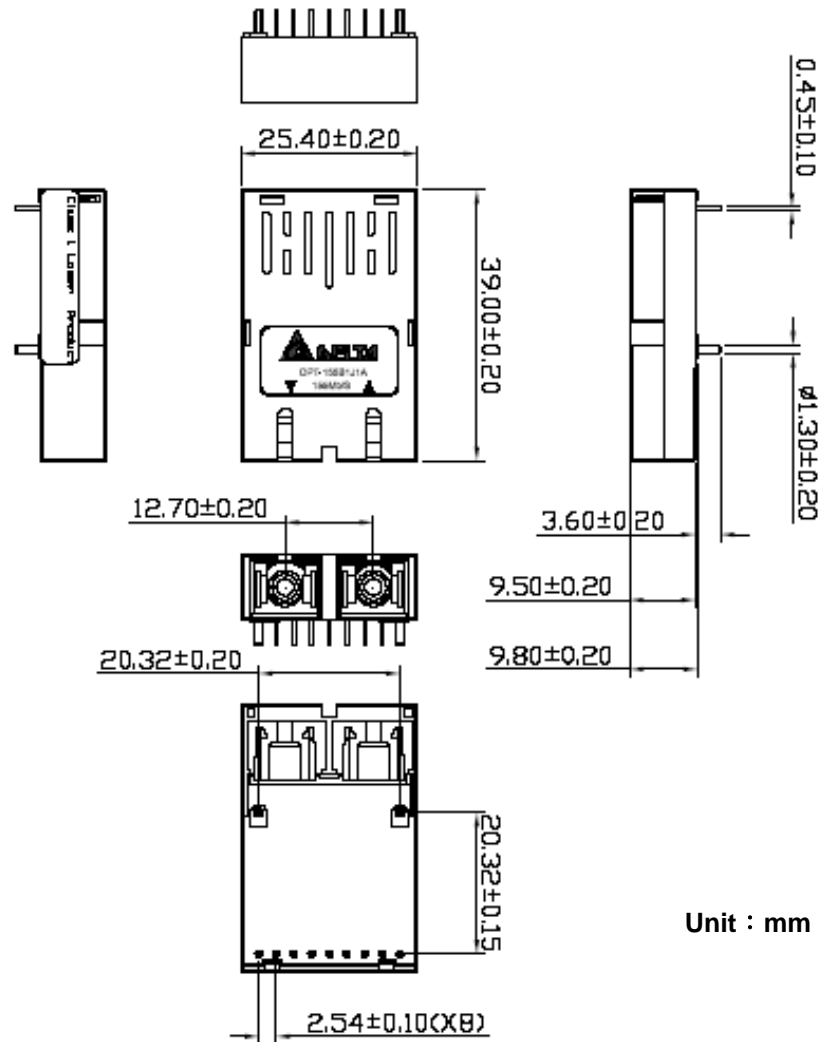

Unit : mm

OPT-155B Series with SC-type Connector

Order information :

OPT-155B_{x₁x₂x₃x₄}

X₁ : Power Supply Voltage and SD Level

- 1 : 5.0V ; Data In/Out (PECL) ; SD Output (PECL)
- 2 : 3.3V ; Data In/Out (PECL) ; SD Output (PECL)
- 3 : 5.0V ; Data In/Out (PECL) ; SD Output (TTL)
- 4 : 3.3V ; Data In/Out (PECL) ; SD Output (TTL)

x₂ : Effective Distance Grade

- H : 2Km
- J : 15Km
- L : 30Km
- M : 40Km

x₃ : Performance

- 1 : Normal

Other Symbol : It represents special specifications that depend on customers' requirement.

x₄ : Temperature

- Blank : 0°C to 70°C
- T : -40°C to 85°C

Regulatory Compliance

Feature	Standard	Comments
Electrostatic Discharge (ESD) to the Electrical Pins	MIL-STD 883C Method 3015.4	Class 1 (>1000 V)
Immunity: Electrostatic Discharge (ESD) to the Duplex SC Receptacle	EN 61000-4-2 IEC 61000-4-2	Discharges of ±15 kV with an air discharge probe on the receptacle cause no damage.
Immunity: Radio Frequency Electromagnetic Field	EN 61000-4-3 IEC 61000-4-3	With a field strength of 10 V/m rms, noise frequency ranges from 3 MHz to 1 GHz. No effect on transceiver performance between the specification limits.
Emission: Electromagnetic Interference (EMI)	FCC Class B EN 55022 Class B CISPR 22	Noise frequency range: 30 MHz to 6 GHz, margins depend on PCB layout and chassis design.