

# Voltage Detector IC Series for Automotive Counter Timer Built-in CMOS Voltage Detector IC

**BD45Exxxx-M series BD46Exxxx-M series**

## ●General Description

ROHM's BD45Exxxx-M and BD46Exxxx-M series are highly accurate, low current consumption Voltage Detector IC series. Because the counter timer delay circuit is built into those series, an external capacitor for the delay time setting is unnecessary. The lineup was established with two output types (Nch open drain and CMOS output) and detection voltages range from 2.3V to 4.8V in increments of 0.1V, so that the series may be selected according to application.

## ●Features

- Counter Timer Built-in
- No delay time setting capacitor required
- Ultra-low current consumption
- Two output types (Nch open drain and CMOS output)
- Package SSOP5 is similar to SOT-23-5 (JEDEC)
- AEC-Q100 Qualified

## ●Key Specifications

- Detection voltage: 2.3V to 4.8V (Typ.)  
0.1V steps
- High accuracy detection voltage: ±1.0%
- Ultra-low current consumption: 0.85μA (Typ.)
- Operating temperature range: -40°C to +105°C
- Three internal, fixed delay time: 50ms  
100ms  
200ms

## ●Package

SSOP5



2.90mm x 2.80mm x 1.25mm

## ●Applications

Circuits using microcontrollers or logic circuits that require a reset for automotive applications (car navigation, car audio, meter panel, exterior lamp etc.)

## ●Typical Application Circuit

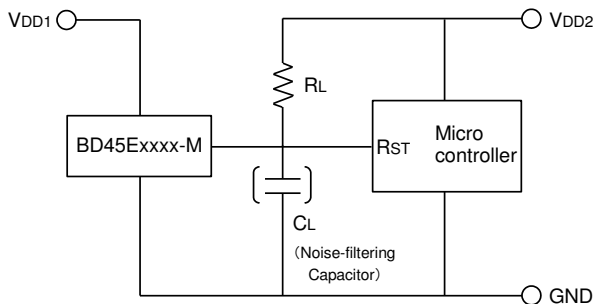

(Open Drain Output Type)  
BD45Exxxx-M series

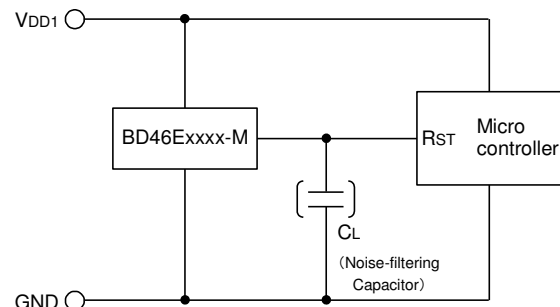

(CMOS Output Type)  
BD46Exxxx-M series

## ●Connection Diagram

SSOP5

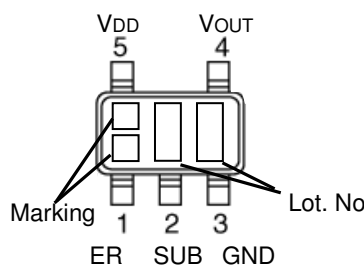

## ●Pin Descriptions

PIN No.	Symbol	Function
1	ER	Manual Reset
2	SUB	Substrate *
3	GND	GND
4	VOUT	Reset Output
5	VDD	Power Supply Voltage

\*Connect the substrate to GND.

●Ordering Information

B		D		x		x		E		x		x		x		x		-		M		T		R	
Part Number	Output Type 45 : Open Drain 46 : CMOS							Reset Voltage Value 23 : 2.3V ↓ 0.1V step 48 : 4.8V			Counter Timer Delay Time Settings 5 : 50ms 1 : 100ms 2 : 200ms			Package G : SSOP5		Product Category M : Automotive Category				Packaging and forming specification TR : Embossed tape and reel					

SSOP5

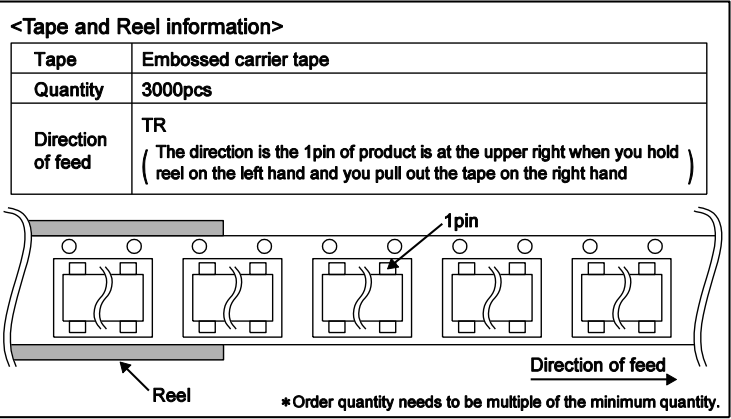
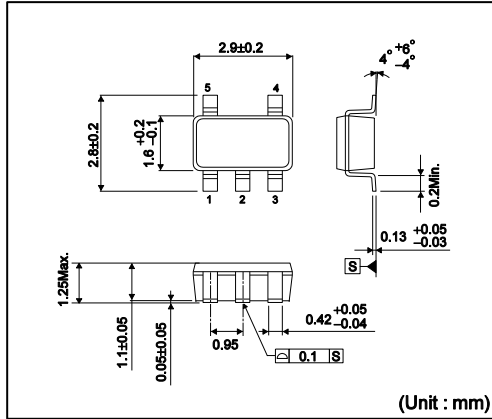

●Lineup

Table 1. Open Drain Output Type

	Counter Timer Delay Time Settings					
	50ms		100ms		200ms	
Detection Voltage	Marking	Part Number	Marking	Part Number	Marking	Part Number
4.8V	a2	BD45E485	d1	BD45E481	f9	BD45E482
4.7V	a1	BD45E475	c9	BD45E471	f8	BD45E472
4.6V	Yy	BD45E465	c8	BD45E461	f7	BD45E462
4.5V	Yr	BD45E455	c7	BD45E451	f6	BD45E452
4.4V	Yp	BD45E445	c6	BD45E441	f5	BD45E442
4.3V	Yn	BD45E435	c5	BD45E431	f4	BD45E432
4.2V	Ym	BD45E425	c4	BD45E421	f3	BD45E422
4.1V	Yk	BD45E415	c3	BD45E411	f2	BD45E412
4.0V	Yh	BD45E405	c2	BD45E401	f1	BD45E402
3.9V	Yg	BD45E395	c1	BD45E391	e9	BD45E392
3.8V	Yf	BD45E385	b9	BD45E381	e8	BD45E382
3.7V	Ye	BD45E375	b8	BD45E371	e7	BD45E372
3.6V	Yd	BD45E365	b7	BD45E361	e6	BD45E362
3.5V	Yc	BD45E355	b6	BD45E351	e5	BD45E352
3.4V	Yb	BD45E345	b5	BD45E341	e4	BD45E342
3.3V	Ya	BD45E335	b4	BD45E331	e3	BD45E332
3.2V	Uy	BD45E325	b3	BD45E321	e2	BD45E322
3.1V	Ur	BD45E315	b2	BD45E311	e1	BD45E312
3.0V	Up	BD45E305	b1	BD45E301	d9	BD45E302
2.9V	Un	BD45E295	a9	BD45E291	d8	BD45E292
2.8V	Um	BD45E285	a8	BD45E281	d7	BD45E282
2.7V	Uk	BD45E275	a7	BD45E271	d6	BD45E272
2.6V	Uh	BD45E265	a6	BD45E261	d5	BD45E262
2.5V	Ug	BD45E255	a5	BD45E251	d4	BD45E252
2.4V	Uf	BD45E245	a4	BD45E241	d3	BD45E242
2.3V	Ue	BD45E235	a3	BD45E231	d2	BD45E232

## ●Lineup - continued

Table 2. CMOS Output Type

Detection Voltage	Counter Timer Delay Time Settings					
	50ms		100ms		200ms	
	Marking	Part Number	Marking	Part Number	Marking	Part Number
4.8V	k8	BD46E485	p7	BD46E481	1f	BD46E482
4.7V	k7	BD46E475	p6	BD46E471	1e	BD46E472
4.6V	k6	BD46E465	p5	BD46E461	1d	BD46E462
4.5V	k5	BD46E455	p4	BD46E451	1c	BD46E452
4.4V	k4	BD46E445	p3	BD46E441	1b	BD46E442
4.3V	k3	BD46E435	p2	BD46E431	1a	BD46E432
4.2V	k2	BD46E425	p1	BD46E421	y9	BD46E422
4.1V	k1	BD46E415	n9	BD46E411	y8	BD46E412
4.0V	h9	BD46E405	n8	BD46E401	y7	BD46E402
3.9V	h8	BD46E395	n7	BD46E391	y6	BD46E392
3.8V	h7	BD46E385	n6	BD46E381	y5	BD46E382
3.7V	h6	BD46E375	n5	BD46E371	y4	BD46E372
3.6V	h5	BD46E365	n4	BD46E361	y3	BD46E362
3.5V	h4	BD46E355	n3	BD46E351	y2	BD46E352
3.4V	h3	BD46E345	n2	BD46E341	y1	BD46E342
3.3V	h2	BD46E335	n1	BD46E331	r9	BD46E332
3.2V	h1	BD46E325	m9	BD46E321	r8	BD46E322
3.1V	g9	BD46E315	m8	BD46E311	r7	BD46E312
3.0V	g8	BD46E305	m7	BD46E301	r6	BD46E302
2.9V	g7	BD46E295	m6	BD46E291	r5	BD46E292
2.8V	g6	BD46E285	m5	BD46E281	r4	BD46E282
2.7V	g5	BD46E275	m4	BD46E271	r3	BD46E272
2.6V	g4	BD46E265	m3	BD46E261	r2	BD46E262
2.5V	g3	BD46E255	m2	BD46E251	r1	BD46E252
2.4V	g2	BD46E245	m1	BD46E241	p9	BD46E242
2.3V	g1	BD46E235	k9	BD46E231	p8	BD46E232

● Absolute maximum ratings

Parameter		Symbol	Limits	Unit
Power Supply Voltage		V <sub>DD-GND</sub>	-0.3 to +10	V
Output Voltage	Nch Open Drain Output	V <sub>OUT</sub>	GND-0.3 to +10	V
	CMOS Output		GND-0.3 to V <sub>DD</sub> +0.3	
Output Current		I <sub>o</sub>	60	mA
ER pin Voltage		V <sub>CT</sub>	GND-0.3 to V <sub>DD</sub> +0.3	V
Power Dissipation *1, *2		P <sub>d</sub>	540	mW
Operating Temperature		T <sub>opr</sub>	-40 to +105	°C
Ambient Storage Temperature		T <sub>stg</sub>	-55 to +125	°C

\*1 Reduced by 5.4mW/°C when used over 25°C.

\*2 When mounted on ROHM standard circuit board (70mm×70mm×1.6mm, glass epoxy board).

● Electrical characteristics (Unless Otherwise Specified Ta=-40 to 105°C)

Parameter	Symbol	Condition	Limit			Unit	
			Min.	Typ.	Max.		
Detection Voltage	V <sub>DET</sub>	V <sub>DD</sub> =H→L, R <sub>L</sub> =470kΩ *1	V <sub>DET</sub> (T) ×0.99	V <sub>DET</sub> (T)	V <sub>DET</sub> (T) ×1.01	V	
		V <sub>DET</sub> =2.5V	Ta=+25°C	2.475	2.5		2.525
			Ta=-40°C to 85°C	2.418	-		2.584
			Ta=85°C to 105°C	2.404	-		2.597
		V <sub>DET</sub> =3.0V	Ta=+25°C	2.970	3.0		3.030
			Ta=-40°C to 85°C	2.901	-		3.100
			Ta=85°C to 105°C	2.885	-		3.117
		V <sub>DET</sub> =3.3V	Ta=+25°C	3.267	3.3		3.333
			Ta=-40°C to 85°C	3.191	-		3.410
			Ta=85°C to 105°C	3.173	-		3.428
		V <sub>DET</sub> =4.2V	Ta=+25°C	4.158	4.2		4.242
			Ta=-40°C to 85°C	4.061	-		4.341
			Ta=85°C to 105°C	4.039	-		4.364
		V <sub>DET</sub> =4.8V	Ta=+25°C	4.752	4.8		4.848
Ta=-40°C to 85°C	4.641		-	4.961			
Ta=85°C to 105°C	4.616		-	4.987			
Detection Voltage Temperature coefficient	V <sub>DET</sub> /ΔT	-40°C to +105°C	-	±100	±360	ppm/°C	
Hysteresis Voltage	ΔV <sub>DET</sub>	V <sub>DD</sub> =L→H→L, R <sub>L</sub> =470kΩ	V <sub>DET</sub> (T) ×0.03	V <sub>DET</sub> (T) ×0.05	V <sub>DET</sub> (T) ×0.08	V	
'High' Output Delay time	t <sub>PLH</sub>	CL=100pF, R <sub>L</sub> =100kΩ	BD45Exx5, BD46Exx5	45	50	55	ms
		*1, *2, *3	BD45Exx1, BD46Exx1	90	100	110	
			BD45Exx2, BD46Exx2	180	200	220	
Circuit Current when ON	I <sub>DD1</sub>	V <sub>DD</sub> =V <sub>DET</sub> -0.2V, V <sub>ER</sub> =0V V <sub>DET</sub> =2.3V to 3.1V *1	-	0.70	2.10	μA	
		V <sub>DD</sub> =V <sub>DET</sub> -0.2V, V <sub>ER</sub> =0V V <sub>DET</sub> =2.3V to 3.1V	-	0.70	2.85		
		V <sub>DD</sub> =V <sub>DET</sub> -0.2V, V <sub>ER</sub> =0V V <sub>DET</sub> =3.2V to 4.2V *1	-	0.75	2.25		
		V <sub>DD</sub> =V <sub>DET</sub> -0.2V, V <sub>ER</sub> =0V V <sub>DET</sub> =3.2V to 4.2V	-	0.75	3.00		
		V <sub>DD</sub> =V <sub>DET</sub> -0.2V, V <sub>ER</sub> =0V V <sub>DET</sub> =4.3V to 4.8V *1	-	0.80	2.40		
Circuit Current when OFF	I <sub>DD2</sub>	V <sub>DD</sub> =V <sub>DET</sub> +0.2V, V <sub>ER</sub> =0V V <sub>DET</sub> =2.3V to 3.1V *1	-	0.75	2.25	μA	
		V <sub>DD</sub> =V <sub>DET</sub> +0.2V, V <sub>ER</sub> =0V V <sub>DET</sub> =2.3V to 3.1V	-	0.75	4.28		
		V <sub>DD</sub> =V <sub>DET</sub> +0.2V, V <sub>ER</sub> =0V V <sub>DET</sub> =3.2V to 4.2V *1	-	0.80	2.40		
		V <sub>DD</sub> =V <sub>DET</sub> +0.2V, V <sub>ER</sub> =0V V <sub>DET</sub> =3.2V to 4.2V	-	0.80	4.50		
		V <sub>DD</sub> =V <sub>DET</sub> +0.2V, V <sub>ER</sub> =0V V <sub>DET</sub> =4.3V to 4.8V *1	-	0.85	2.55		
		V <sub>DD</sub> =V <sub>DET</sub> +0.2V, V <sub>ER</sub> =0V V <sub>DET</sub> =4.3V to 4.8V	-	0.85	4.73		

V<sub>DET</sub>(T):Standard Detection Voltage (2.3V to 4.8V, 0.1V step)

R<sub>L</sub>:Pull-up resistor to be connected between V<sub>OUT</sub> and power supply.

C<sub>L</sub>:Capacitor to be connected between V<sub>OUT</sub> and GND.

\*1 Guarantee is Ta=25°C.

\*2 t<sub>PLH</sub>:V<sub>DD</sub>=(V<sub>DET</sub>(T)-0.5V)→(V<sub>DET</sub>(T)+0.5V)

\*3 t<sub>PLH</sub>:V<sub>DD</sub>=Please set up the rise up time between V<sub>DD</sub>=0→V<sub>DET</sub> more than 100μs.

Attention: Please connect 'ER' to the GND when not in use.

## ●Electrical characteristics (Unless Otherwise Specified Ta=-40 to 105°C) – continued

Parameter	Symbol	Condition	Limit			Unit
			Min.	Typ.	Max.	
Operating Voltage Range	VOPL	VOL≤0.4V, RL=470kΩ, Ta=25 to 105°C	0.95	-	-	V
		VOL≤0.4V, RL=470kΩ, Ta=-40 to 25°C	1.20	-	-	
'High' Output Voltage (Pch)	VOH	VDD=4.8V, ISOURCE= 1.0 mA, VDET(2.3V to 4.2V)	VDD-0.5	-	-	V
		VDD=6.0V, ISOURCE= 1.2 mA, VDET(4.3V to 4.8V)	VDD-0.5	-	-	
'Low' Output Voltage (Nch)	VOL	VDD=1.2V, ISINK = 0.45 mA	-	-	0.3	V
		VDD=2.4V, ISINK = 1.3 mA, VDET(2.7V to 4.8V)	-	-	0.3	
Leak Current when OFF	I <sub>leak</sub>	VDD=VDS=10V	-	-	0.1	μA
ER Pin 'H' Voltage	VEH	*1	2.0	-	-	V
ER Pin 'L' Voltage	VEL	*1	-	-	0.8	V
ER Pin Input Current	IEL		-	1	10	μA

VDET(T):Standard Detection Voltage (2.3V to 4.8V, 0.1V step)

RL :Pull-up resistor to be connected between VOUT and power supply.

CL :Capacitor to be connected between VOUT and GND.

\*1 Guarantee is Ta=25°C.

Attention: Please connect 'ER' to the GND when not in use.

●Block Diagrams

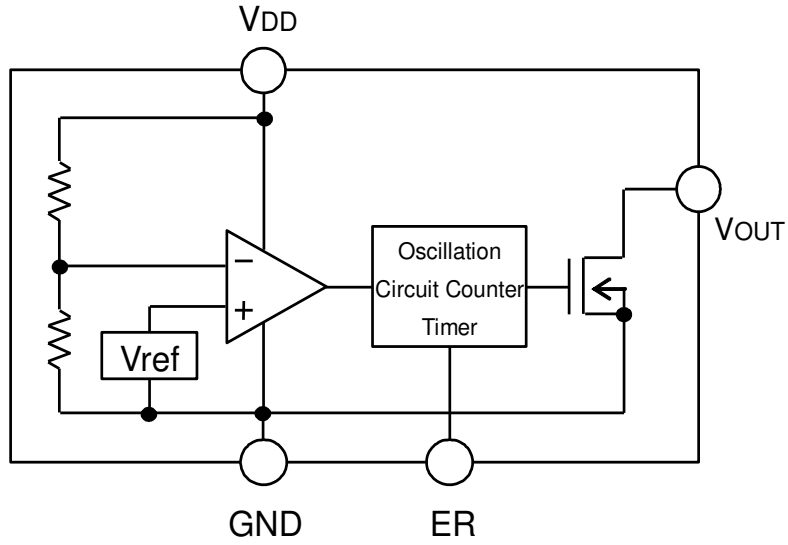

Fig.1 BD45Exxxx-M Series

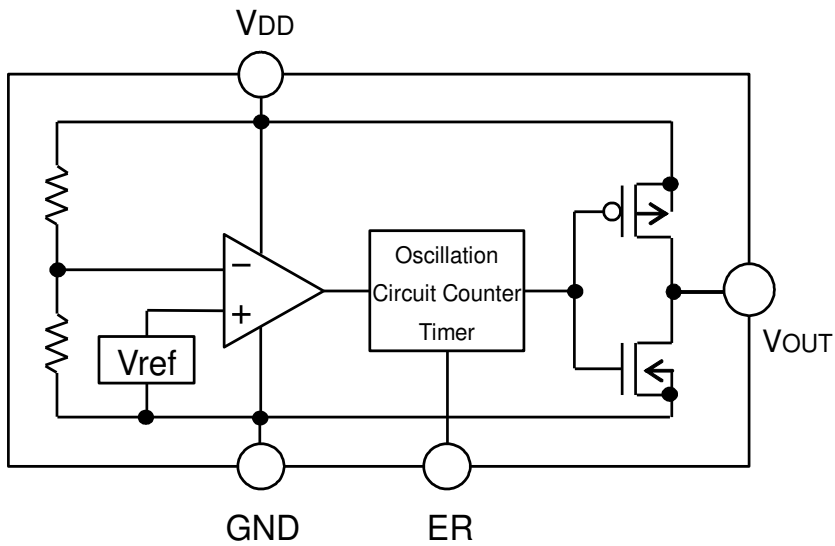

Fig.2 BD46Exxxx-M Series

● Typical Performance Curves

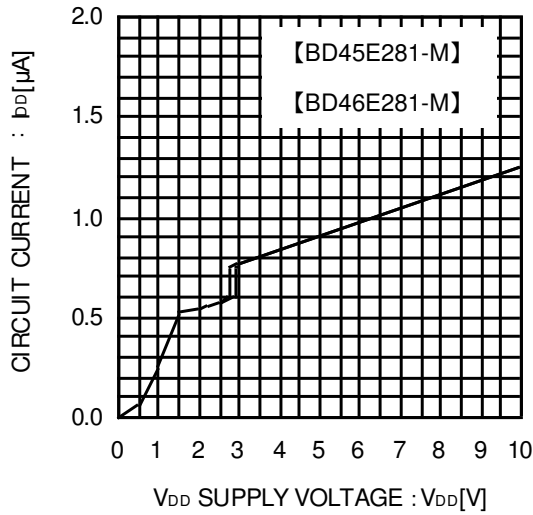

Fig.3 Circuit Current

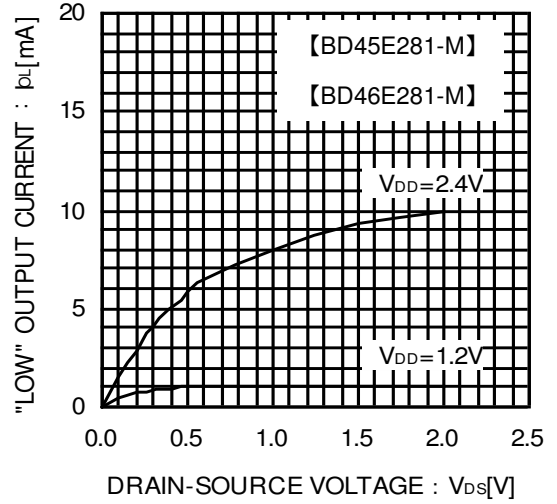

Fig.4 "Low" Output Current

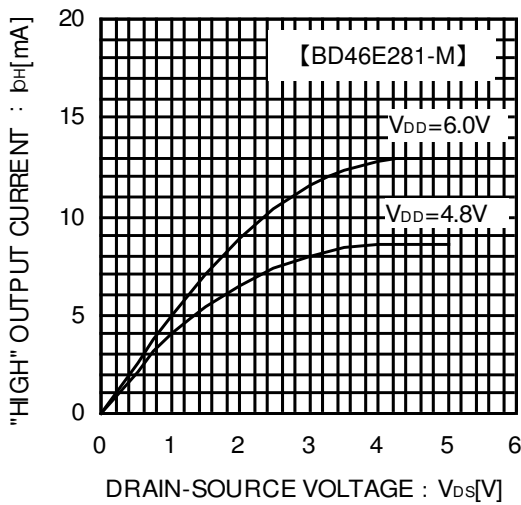

Fig.5 "High" Output Current

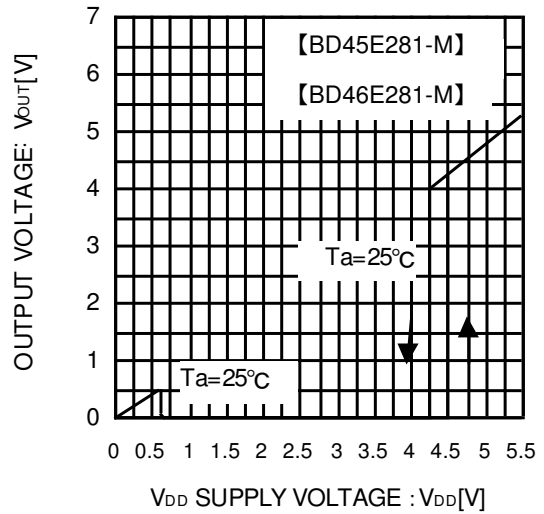

Fig.6 I/O Characteristics

● Typical Performance Curves – continued

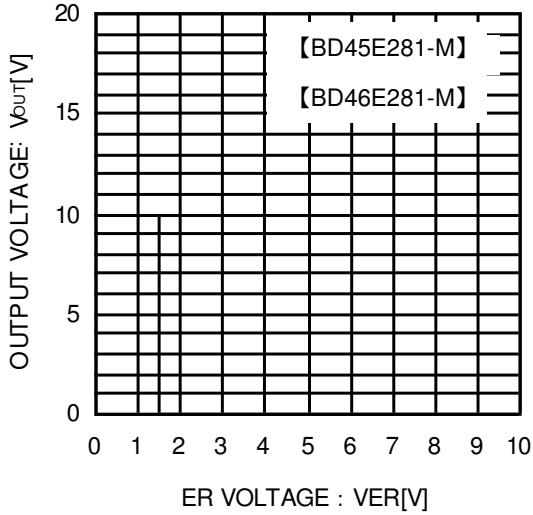

Fig.7 ER Terminal Threshold Voltage

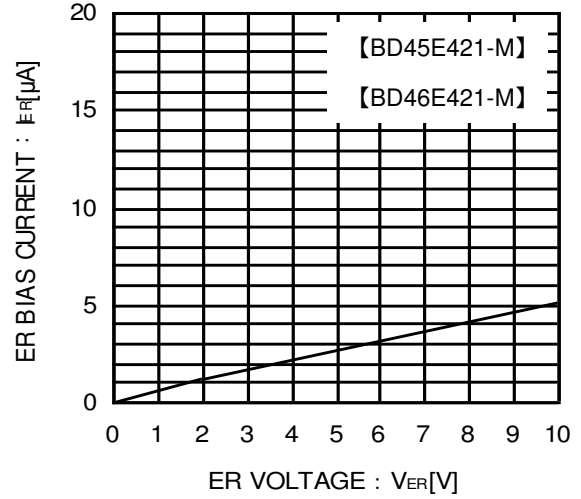

Fig.8 ER Terminal Input Current

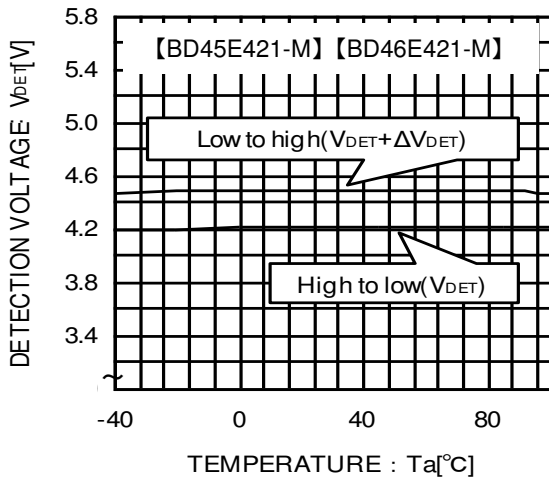

Fig.9 Detection Voltage Release Voltage

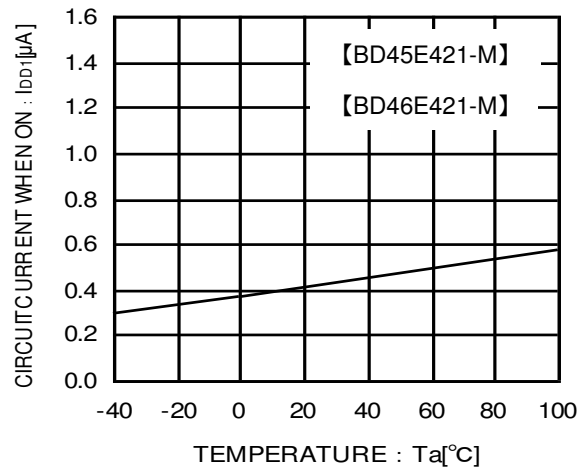

Fig.10 Circuit Current when ON (VDET=0.2V)



● Typical Performance Curves – continued

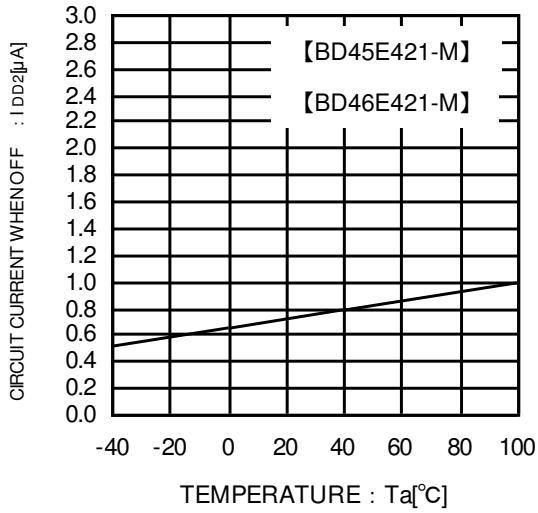

Fig.11 Circuit Current when OFF

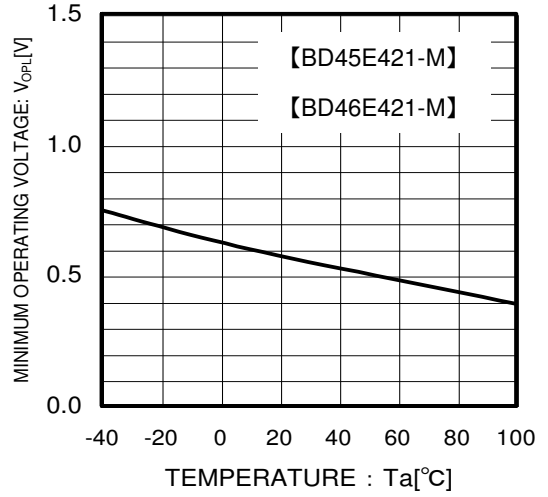

Fig.12 Operating Limit Voltage

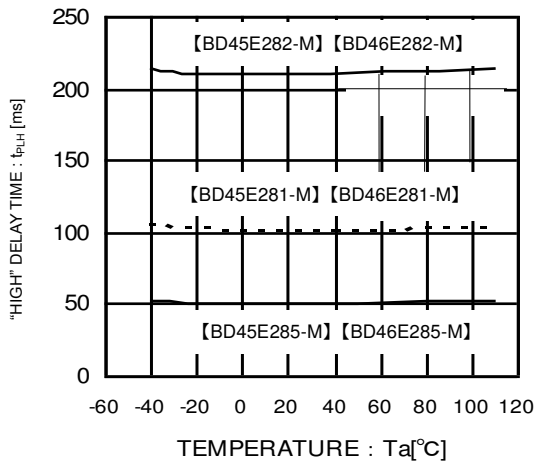

Fig.13 Output Delay Time  
"Low"  $\rightarrow$  "High"

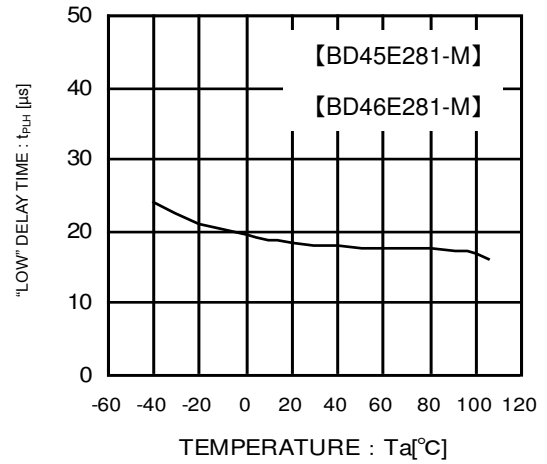

Fig.14 Output Delay Time  
"High"  $\rightarrow$  "Low"

● Application Information

Explanation of Operation

For both the open drain type (Fig.15) and the CMOS output type (Fig.16), the detection and release voltages are used as threshold voltages. When the voltage applied to the  $V_{DD}$  pins reaches the applicable threshold voltage, the  $V_{OUT}$  terminal voltage switches from either “High” to “Low” or from “Low” to “High”. Because the BD45Exxxx-M series uses an open drain output type, it is necessary to connect a pull-up resistor to  $V_{DD}$  or another power supply if needed [The output “High” voltage ( $V_{OUT}$ ) in this case becomes  $V_{DD}$  or the voltage of the other power supply].

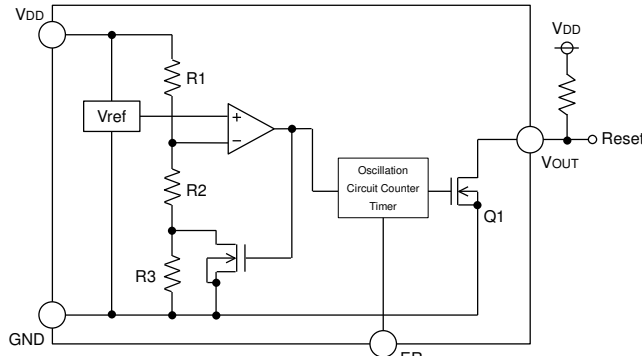

Fig.15 (BD45Exxxx-M Type Internal Block Diagram)

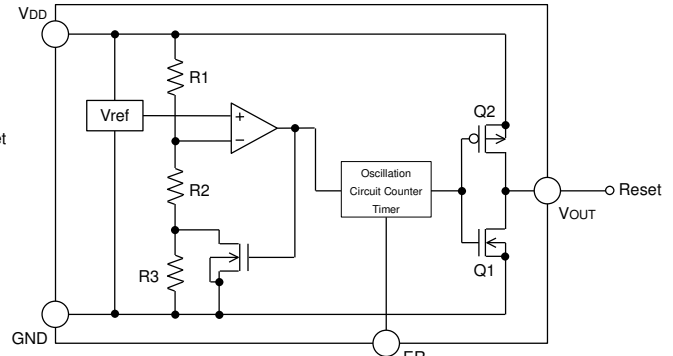

Fig.16 (BD46Exxxx-M Type Internal Block Diagram)

Reference Data

Examples of Leading ( $t_{PLH}$ ) and Falling ( $t_{PHL}$ ) Output

Part Number	$t_{PLH}$ [ms]	$t_{PHL}$ [ $\mu$ s]
BD45E275G-M	50	18
BD46E275G-M	50	18

$V_{DD}=2.2V \rightarrow 3.2V$

$V_{DD}=3.2V \rightarrow 2.2V$

\*This data is for reference only.

The figures will vary with the application, so please confirm actual operating conditions before use.

Timing Waveform

Example: The following shows the relationship between the input voltages  $V_{DD}$ , the output voltage  $V_{OUT}$  and ER terminal when the input power supply voltage  $V_{DD}$  is made to sweep up and sweep down (the circuits are those in Fig. 15 and 16).

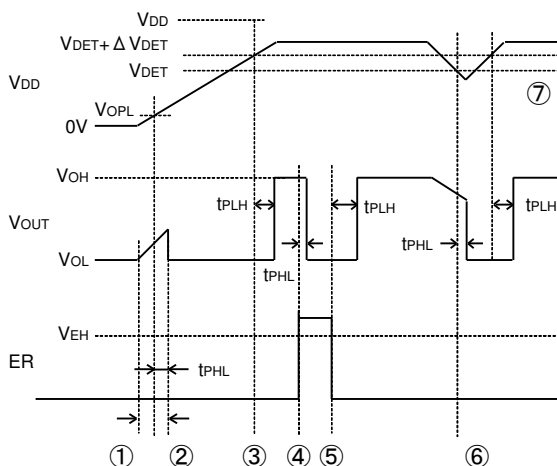

Fig.17 Timing Waveform

- ① When the power supply is turned on, the output is unstable from after over the operating limit voltage ( $V_{OPL}$ ) until  $t_{PHL}$ . Therefore it is possible that the reset signal is not outputted when the rise time of  $V_{DD}$  is faster than  $t_{PHL}$ .
- ② When  $V_{DD}$  is greater than  $V_{OPL}$  but less than the reset release voltage ( $V_{DE} + \Delta V_{DE}$ ), the output voltages will switch to Low.
- ③ If  $V_{DD}$  exceeds the reset release voltage ( $V_{DE} + \Delta V_{DE}$ ), the counter timer start and  $V_{OUT}$  switches from L to H.
- ④ When more than the high level voltage is supplied ER terminal,  $V_{OUT}$  comes to “L” after  $t_{PLH}$  delay time. Therefore, a time when ER terminal is “H” is necessary for 100 $\mu$ sec or more.
- ⑤ When the ER terminal switches to Low, the counter timer starts to operate, a delay of  $t_{PLH}$  occurs, and  $V_{OUT}$  switches from “L” to “H”.
- ⑥ If  $V_{DD}$  drops below the detection voltage ( $V_{DE}$ ) when the power supply is powered down or when there is a power supply fluctuation,  $V_{OUT}$  switches to L (with a delay of  $t_{PHL}$ ).
- ⑦ The potential difference between the detection voltage and the release voltage is known as the hysteresis width ( $\Delta V_{DE}$ ). The system is designed such that the output does not toggle with power supply fluctuations within this hysteresis width, thus, preventing malfunctions due to noise.

Timing may change depending on application and use. Please verify and confirm using practical applications.

● Circuit Applications

- 1) Examples of a common power supply detection reset circuit.

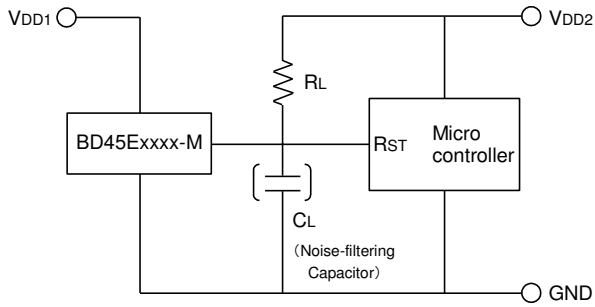

Fig.18 Open Drain Output Type

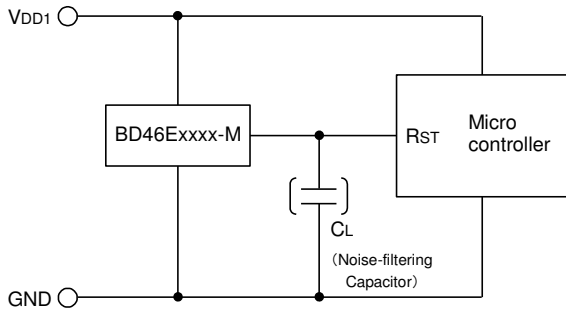

Fig.19 CMOS Output Type

Application examples of BD45Exxxx-M series (Open Drain output type) and BD46Exxxx-M series (CMOS output type) are shown below.

CASE1: Power supply of microcontroller ( $V_{DD2}$ ) differs from the power supply of the reset detection ( $V_{DD1}$ ). Use an open drain output Type (BD45xx series) device with a load resistance  $R_L$  as shown Fig.18.

CASE2: Power supply of the microcontroller ( $V_{DD1}$ ) is same as the power supply of the reset detection ( $V_{DD1}$ ). Use a CMOS output type (BD46Exxxx-M) device or an open drain output type (BD45Exxxx-M) with a pull up resistor between the output and  $V_{DD1}$ .

When a capacitance  $C_L$  for noise filtering is connected to the  $V_{OUT}$  pin (the reset signal input terminal of the microcontroller), please take into account the waveform of the rise and fall of the output voltage ( $V_{OUT}$ ).

- 2) The following is an example of a circuit application in which an OR connection between two types of detection voltage resets the microcontroller.

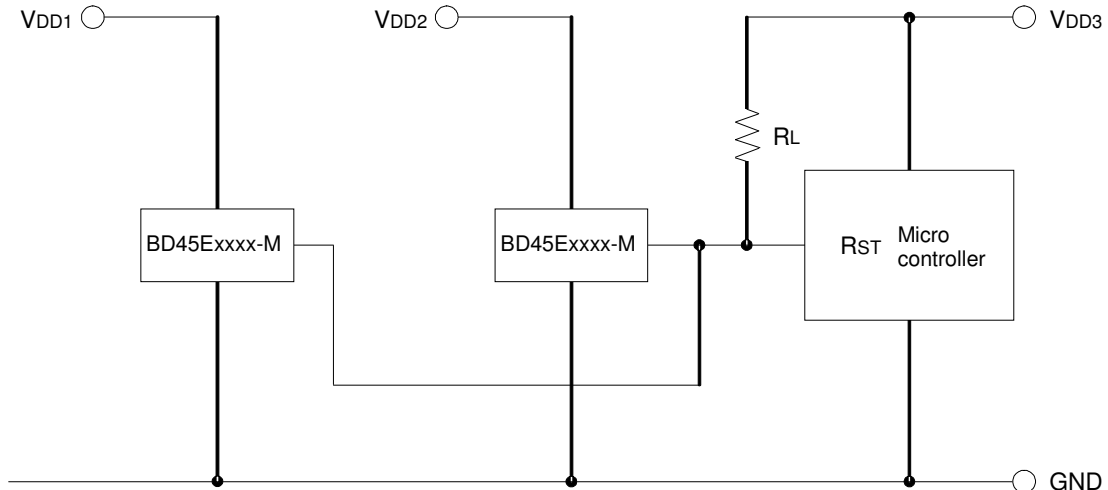

Fig. 20

To reset the microcontroller when many independent power supplies are used in the system, OR connect an open drain output type (BD45Exxxx-M series) to the microcontroller's input with pull-up resistor to the supply voltage of the microcontroller ( $V_{DD3}$ ) as shown in Fig. 20. By pulling-up to  $V_{DD3}$ , output "High" voltage of micro-controller power supply is possible.

3) Examples of the power supply with resistor dividers.

In applications wherein the power supply voltage of an IC comes from a resistor divider circuit, an in-rush current will flow into the circuit when the output level switches from “High” to “Low” or vice versa. In-rush current is a sudden surge of current that flows from the power supply (VDD) to ground (GND) as the output logic changes its state. This current flow may cause malfunction in the systems operation such as output oscillations, etc.

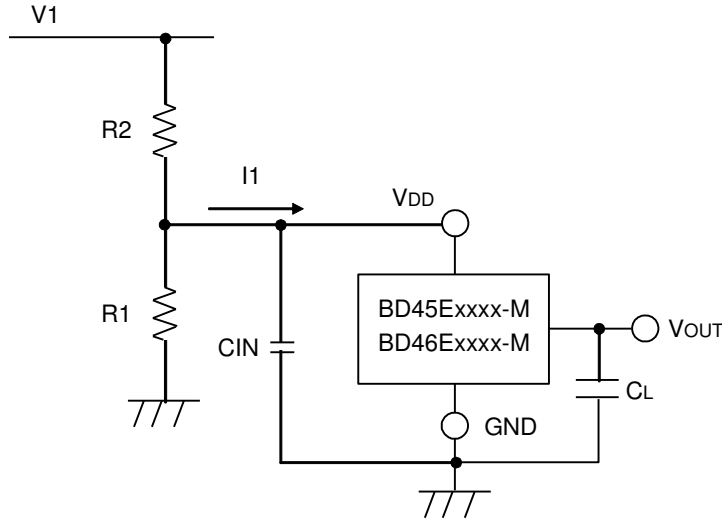

Fig. 21

When an in-rush current ( $I_1$ ) flows into the circuit (Refer to Fig. 21) at the time when output switches from “Low” to “High”, a voltage drop of  $I_1 \times R_2$  (input resistor) will occur in the circuit causing the VDD supply voltage to decrease. When the VDD voltage drops below the detection voltage, the output will switch from “High” to “Low”. While the output voltage is at “Low” condition, in-rush current will stop flowing and the voltage drop will be reduced. As a result, the output voltage will switch again from “Low” to “High” which causes an in-rush current and a voltage drop. This operation repeats and will result to oscillation.

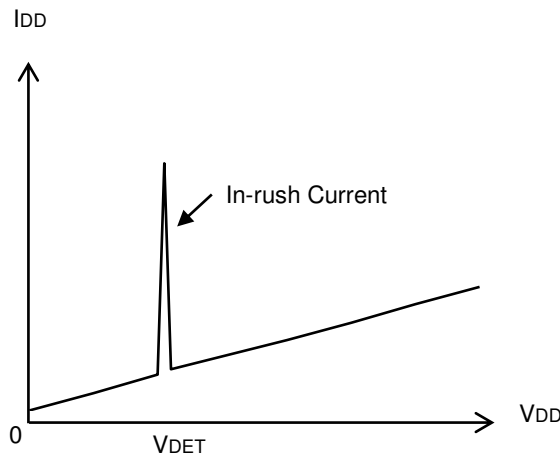

Fig. 22 Current Consumption vs. Power Supply Voltage

**●Operational Notes**

- 1) Absolute maximum ratings  
Operating the IC over the absolute maximum ratings may damage the IC. The damage can either be a short circuit between pins or an open circuit between pins. Therefore, it is important to consider circuit protection measures, such as adding a fuse, in case the IC is operated over the absolute maximum ratings.
- 2) Ground Voltage  
The voltage of the ground pin must be the lowest voltage of all pins of the IC at all operating conditions. Ensure that no pins are at a voltage below the ground pin at any time, even during transient condition.
- 3) Recommended operating conditions  
These conditions represent a range within which the expected characteristics of the IC can be approximately obtained. The electrical characteristics are guaranteed under the conditions of each parameter.
- 4) Bypass Capacitor for Noise Rejection  
To help reject noise, put a 1 $\mu$ F capacitor between V<sub>DD</sub> pin and GND and 1000pF capacitor between V<sub>OUT</sub> pin and GND. Be careful when using extremely big capacitor as transient response will be affected.
- 5) Short between pins and mounting errors  
Be careful when mounting the IC on printed circuit boards. The IC may be damaged if it is mounted in a wrong orientation or if pins are shorted together. Short circuit may be caused by conductive particles caught between the pins.
- 6) Operation under strong electromagnetic field  
Operating the IC in the presence of a strong electromagnetic field may cause the IC to malfunction.
- 7) The V<sub>DD</sub> line impedance might cause oscillation because of the detection current.
- 8) A V<sub>DD</sub> to GND capacitor (as close connection as possible) should be used in high V<sub>DD</sub> line impedance condition.
- 9) Lower than the minimum input voltage puts the V<sub>OUT</sub> in high impedance state, and it must be V<sub>DD</sub> in pull up (V<sub>DD</sub>) condition.
- 10) This IC has extremely high impedance terminals. Small leak current due to the uncleanness of PCB surface might cause unexpected operations. Application values in these conditions should be selected carefully. If the leakage of about 1M $\Omega$  is assumed between the ER terminal and the GND terminal, 100k $\Omega$  connection between the ER terminal and the V<sub>DD</sub> terminal would be recommended. If the leakage is assumed between the V<sub>OUT</sub> terminal and the GND terminal, the pull-up resistor should be less than 1/10 of the assumed leak resistance.
- 11) External parameters  
The recommended parameter range for R<sub>L</sub> is 50k $\Omega$  to 1M $\Omega$ . There are many factors (board layout, etc) that can affect characteristics. Please verify and confirm using practical applications.
- 12) Power on reset operation  
Please note that the power on reset output varies with the V<sub>DD</sub> rise time. Please verify the behavior in the actual operation.
- 13) Testing on application boards  
When testing the IC on an application board, connecting a capacitor directly to a low-impedance output pin may subject the IC to stress. Always discharge capacitors completely after each process or step. The IC's power supply should always be turned off completely before connecting or removing it from the test setup during the inspection process. To prevent damage from static discharge, ground the IC during assembly and use similar precautions during transport and storage.
- 14) Rush current  
When the power supply, is turned on because of in certain cases, momentary Rash-current flow into the IC at the logic unsettled, the couple capacitance, GND pattern of width and leading line must be considered.

## ●Revision History

Date	Revision	Changes
20.Nov.2012	001	New Release
18.Dec.2012	002	Change the value of "Counter Timer Delay" from 5ms to 50ms in Table1 and Table2. Change unit of Operating Limit Voltage graph from $\mu\text{A}$ to V in Typical Performance Curve.
23.May.2013	003	Change limits for VDET at VDET=2.5V,3.0V,3.3V,4.2V,4.8V
27.Aug.2013	004	Update the applications and features on page 1 and ordering information on page 2

# Notice

## Precaution on using ROHM Products

1. If you intend to use our Products in devices requiring extremely high reliability (such as medical equipment <sup>(Note 1)</sup>, aircraft/spacecraft, nuclear power controllers, etc.) and whose malfunction or failure may cause loss of human life, bodily injury or serious damage to property ("Specific Applications"), please consult with the ROHM sales representative in advance. Unless otherwise agreed in writing by ROHM in advance, ROHM shall not be in any way responsible or liable for any damages, expenses or losses incurred by you or third parties arising from the use of any ROHM's Products for Specific Applications.

(Note1) Medical Equipment Classification of the Specific Applications

JAPAN	USA	EU	CHINA
CLASS III	CLASS III	CLASS II b	CLASS III
CLASS IV		CLASS III	

2. ROHM designs and manufactures its Products subject to strict quality control system. However, semiconductor products can fail or malfunction at a certain rate. Please be sure to implement, at your own responsibilities, adequate safety measures including but not limited to fail-safe design against the physical injury, damage to any property, which a failure or malfunction of our Products may cause. The following are examples of safety measures:
  - [a] Installation of protection circuits or other protective devices to improve system safety
  - [b] Installation of redundant circuits to reduce the impact of single or multiple circuit failure
3. Our Products are not designed under any special or extraordinary environments or conditions, as exemplified below. Accordingly, ROHM shall not be in any way responsible or liable for any damages, expenses or losses arising from the use of any ROHM's Products under any special or extraordinary environments or conditions. If you intend to use our Products under any special or extraordinary environments or conditions (as exemplified below), your independent verification and confirmation of product performance, reliability, etc, prior to use, must be necessary:
  - [a] Use of our Products in any types of liquid, including water, oils, chemicals, and organic solvents
  - [b] Use of our Products outdoors or in places where the Products are exposed to direct sunlight or dust
  - [c] Use of our Products in places where the Products are exposed to sea wind or corrosive gases, including Cl<sub>2</sub>, H<sub>2</sub>S, NH<sub>3</sub>, SO<sub>2</sub>, and NO<sub>2</sub>
  - [d] Use of our Products in places where the Products are exposed to static electricity or electromagnetic waves
  - [e] Use of our Products in proximity to heat-producing components, plastic cords, or other flammable items
  - [f] Sealing or coating our Products with resin or other coating materials
  - [g] Use of our Products without cleaning residue of flux (even if you use no-clean type fluxes, cleaning residue of flux is recommended); or Washing our Products by using water or water-soluble cleaning agents for cleaning residue after soldering
  - [h] Use of the Products in places subject to dew condensation
4. The Products are not subject to radiation-proof design.
5. Please verify and confirm characteristics of the final or mounted products in using the Products.
6. In particular, if a transient load (a large amount of load applied in a short period of time, such as pulse. is applied, confirmation of performance characteristics after on-board mounting is strongly recommended. Avoid applying power exceeding normal rated power; exceeding the power rating under steady-state loading condition may negatively affect product performance and reliability.
7. De-rate Power Dissipation (Pd) depending on Ambient temperature (Ta). When used in sealed area, confirm the actual ambient temperature.
8. Confirm that operation temperature is within the specified range described in the product specification.
9. ROHM shall not be in any way responsible or liable for failure induced under deviant condition from what is defined in this document.

## Precaution for Mounting / Circuit board design

1. When a highly active halogenous (chlorine, bromine, etc.) flux is used, the residue of flux may negatively affect product performance and reliability.
2. In principle, the reflow soldering method must be used; if flow soldering method is preferred, please consult with the ROHM representative in advance.

For details, please refer to ROHM Mounting specification

**Precautions Regarding Application Examples and External Circuits**

1. If change is made to the constant of an external circuit, please allow a sufficient margin considering variations of the characteristics of the Products and external components, including transient characteristics, as well as static characteristics.
2. You agree that application notes, reference designs, and associated data and information contained in this document are presented only as guidance for Products use. Therefore, in case you use such information, you are solely responsible for it and you must exercise your own independent verification and judgment in the use of such information contained in this document. ROHM shall not be in any way responsible or liable for any damages, expenses or losses incurred by you or third parties arising from the use of such information.

**Precaution for Electrostatic**

This Product is electrostatic sensitive product, which may be damaged due to electrostatic discharge. Please take proper caution in your manufacturing process and storage so that voltage exceeding the Products maximum rating will not be applied to Products. Please take special care under dry condition (e.g. Grounding of human body / equipment / solder iron, isolation from charged objects, setting of ionizer, friction prevention and temperature / humidity control).

**Precaution for Storage / Transportation**

1. Product performance and soldered connections may deteriorate if the Products are stored in the places where:
  - [a] the Products are exposed to sea winds or corrosive gases, including Cl<sub>2</sub>, H<sub>2</sub>S, NH<sub>3</sub>, SO<sub>2</sub>, and NO<sub>2</sub>
  - [b] the temperature or humidity exceeds those recommended by ROHM
  - [c] the Products are exposed to direct sunshine or condensation
  - [d] the Products are exposed to high Electrostatic
2. Even under ROHM recommended storage condition, solderability of products out of recommended storage time period may be degraded. It is strongly recommended to confirm solderability before using Products of which storage time is exceeding the recommended storage time period.
3. Store / transport cartons in the correct direction, which is indicated on a carton with a symbol. Otherwise bent leads may occur due to excessive stress applied when dropping of a carton.
4. Use Products within the specified time after opening a humidity barrier bag. Baking is required before using Products of which storage time is exceeding the recommended storage time period.

**Precaution for Product Label**

QR code printed on ROHM Products label is for ROHM's internal use only.

**Precaution for Disposition**

When disposing Products please dispose them properly using an authorized industry waste company.

**Precaution for Foreign Exchange and Foreign Trade act**

Since our Products might fall under controlled goods prescribed by the applicable foreign exchange and foreign trade act, please consult with ROHM representative in case of export.

**Precaution Regarding Intellectual Property Rights**

1. All information and data including but not limited to application example contained in this document is for reference only. ROHM does not warrant that foregoing information or data will not infringe any intellectual property rights or any other rights of any third party regarding such information or data. ROHM shall not be in any way responsible or liable for infringement of any intellectual property rights or other damages arising from use of such information or data.:
2. No license, expressly or implied, is granted hereby under any intellectual property rights or other rights of ROHM or any third parties with respect to the information contained in this document.

**Other Precaution**

1. This document may not be reprinted or reproduced, in whole or in part, without prior written consent of ROHM.
2. The Products may not be disassembled, converted, modified, reproduced or otherwise changed without prior written consent of ROHM.
3. In no event shall you use in any way whatsoever the Products and the related technical information contained in the Products or this document for any military purposes, including but not limited to, the development of mass-destruction weapons.
4. The proper names of companies or products described in this document are trademarks or registered trademarks of ROHM, its affiliated companies or third parties.



**General Precaution**

1. Before you use our Products, you are requested to carefully read this document and fully understand its contents. ROHM shall not be in any way responsible or liable for failure, malfunction or accident arising from the use of any ROHM's Products against warning, caution or note contained in this document.
2. All information contained in this document is current as of the issuing date and subject to change without any prior notice. Before purchasing or using ROHM's Products, please confirm the latest information with a ROHM sales representative.
3. The information contained in this document is provided on an "as is" basis and ROHM does not warrant that all information contained in this document is accurate and/or error-free. ROHM shall not be in any way responsible or liable for any damages, expenses or losses incurred by you or third parties resulting from inaccuracy or errors of or concerning such information.