

GENERAL DESCRIPTION

The Teridian Semiconductor Corporation 73S1217F is a versatile and economical CMOS System-on-Chip device intended for smart card reader applications. The circuit features an ISO-7816 / EMV interface, an USB 2.0 interface (full-speed 12Mbps - slave) and a 5x6 PINpad interface. Additional features include 8 user I/Os, multiple interrupt options and an analog voltage input (for DC voltage monitoring such as battery level detection). Other built-in interfaces include an asynchronous serial and an I²C interface.

The System-on-Chip is built around an 80515 high-performance core. Its feature and instruction set is compatible with the industry standard 8051, while offering one clock-cycle per instruction processing power (most instructions). With a CPU clock running up to 24MHz, it results in up to 20MIPS available that meets the requirements of various encryption needs such as AES, DES / 3-DES and even RSA (for PIN encryption for instance). The circuit requires a single 6 to 12 MHz crystal. An optional 32kHz crystal can be connected to a sub-system oscillator with a real-time-clock counter to enable stand-alone applications to access an RTC value.

The respective 73S1217F embedded memories are; 64KB Flash program memory, 2KB user XRAM memory, and 256B IRAM memory. On top of these memories are added independent FIFOs dedicated to the ISO7816 UART and to the USB interface.

The chip incorporates an inductor-based DC-DC converter that generates all the necessary voltages to the various 73S1217F function blocks (smart card interface, digital core, etc.) from any of two distinct power supply sources: The +5V USB bus (V_{BUS} , 4.4V to 6.5V), or a main battery (V_{BAT} , 4.0V to 6.5V). The chip automatically powers-up the DC-DC converter with V_{BUS} if it is present, or uses V_{BAT} as the supply input. Alternatively, the pin V_{PC} can support a wider power supply input range (2.7V to 6.5V), when using a single system supply source.

In addition, the circuit features an ON/OFF mode which operates directly with an ON/OFF system switch: Any activity on the ON/OFF button is debounced internally and controls the power generation circuit accordingly, under the supervision of the firmware (OFF request / OFF acknowledgement at firmware level). The OFF mode can be alternatively initiated from the controller (firmware action instead of ON/OFF switch).

In OFF mode, the circuit typically draws less than 1 μ A, which makes it ideal for applications where battery life must be maximized.

Wake-up of the controller upon USB cable insertion is supported.

Embedded Flash memory is in-system programmable and lockable by means of on-silicon fuses. This makes the Teridian 73S1217F suitable for both development and production phases.

Teridian Semiconductor Corporation offers with its 73S1217F a very comprehensive set of software libraries, including the smart card and USB protocol layers that are pre-approved against USB, Microsoft WHQL and EMV, as well as a CCID reference design. Refer to the Teridian Semiconductor Corporation *73S12xxF Software User's Guide* for a complete description of the Application Programming Interface (API Libraries) and related Software modules.

A complete array of development and programming tools, libraries and demonstration boards enable rapid development and certification of readers that meet most demanding smart card standards.

APPLICATIONS

- Hand-held PINpad smart card readers:
- With USB or serial connectivity
- Ideal for E-banking (MasterCard CAP, etc) and Digital Identification (Secure Login, Gov't ID...)
- Transparent USB card readers and USB keys
- General purpose smart card readers

ADVANTAGES

- Reduced BOM
- Larger built-in Flash / RAM than its competitors
- Higher performance CPU core (up to 24MIPS)
- On-chip DC-DC converter and CMOS switches for battery and USB power
- Sub- μ A Power Down mode with ON/OFF switch
- Powerful In-Circuit Emulation and Programming
- A complete set of EMV4.1, USB and CCID libraries
- Overall, the ideal compromise cost / features for high volume, PINpad reader applications!

FEATURES

80515 Core:

- 1 clock cycle per instruction (most instructions)
- CPU clocked up to 24MHz
- 64kB Flash memory (lockable)
- 2kB XRAM (User Data Memory)
- 256 byte IRAM
- Hardware watchdog timer

Oscillators:

- Single low-cost 6MHz to 12MHz crystal
- Optional 32kHz crystal (with internal RTC)
- An Internal PLL provides all the necessary clocks to each block of the system

Interrupts:

- Standard 80C515 4-priority level structure
- 9 different sources of interrupt to the core

Power Down Modes:

- 2 standard 80C515 Power Down and IDLE modes
- Sub- μ A OFF mode

ON/OFF Main System Power Switch:

- Input for an SPST momentary switch to ground

Timers:

- (2) Standard 80C52 timers T0 and T1
- (1) 16-bit timer that can generate RTC interrupts from the 32kHz clock

Built-in ISO-7816 Card Interface:

- LDO regulator produces VCC for the card
- (1.8V, 3V or 5V)
- Full compliance with EMV 4.1
- Activation/Deactivation sequencers
- Auxiliary I/O lines (C4-C8 signals)
- 7kV ESD protection on all interface pins

Communication with Smart Cards:

- ISO 7816 UART for T=0, T=1
- (2) 2-Byte FIFOs for transmit and receive
- Configured to drive multiple external Teridian 73S8010xx interfaces (for multi-SAM architectures)

Communication Interfaces:

- Full-duplex serial interface (1200 to 115kbps UART)
- USB 2.0 Full Speed 12Mbps Interface, PC/SC compliant with 4 Endpoints:
- Control (16B FIFO)
- Interrupt IN (32B FIFO)
- Bulk IN (128B FIFO)
- Bulk OUT (128B FIFO)
- I²C Master Interface (400kbps)

Man-Machine Interface and I/Os:

- 6x5 Keyboard (hardware scanning, debouncing and scrambling)
- (8) User I/Os
- Single programmable current output (LED)

Voltage Detection:

- Analog Input (detection range: 1.0V to 1.5V)

Operating Voltage:

- Single supply 2.7V to 6.5V operation (VPC)
- USB supply (VBUS 4.4V to 5.5V) with or without battery back up operation (VBAT 4.0V to 6.5V).
- Automated detection of voltage presence - Priority on VBUS over VBAT

DC-DC Converter:

- Step-up converter
- Generates an intermediary voltage VP
- Requires a single 10 μ H Inductor
- 3.3V supply available for external circuits

Operating Temperature:

- -40°C to 85°C

Package:

- 68-pin QFN

Software:

- Two-level Application Programming Interface (ANSI C-language libraries)
- USB, T=0 / T=1 ISO and EMV compliant smart card protocol layers
- CCID reference design and Windows[®] driver

Table of Contents

| | | |
|----------|--|------------|
| 1 | Hardware Description | 8 |
| 1.1 | Pin Description..... | 8 |
| 1.2 | Hardware Overview | 11 |
| 1.3 | 80515 MPU Core..... | 11 |
| 1.3.1 | 80515 Overview..... | 11 |
| 1.3.2 | Memory Organization | 11 |
| 1.4 | Program Security..... | 16 |
| 1.5 | Special Function Registers (SFRs)..... | 18 |
| 1.5.1 | Internal Data Special Function Registers (SFRs)..... | 18 |
| 1.5.2 | IRAM Special Function Registers (Generic 80515 SFRs) | 19 |
| 1.5.3 | External Data Special Function Registers (SFRs) | 20 |
| 1.6 | Instruction Set..... | 23 |
| 1.7 | Peripheral Descriptions..... | 23 |
| 1.7.1 | Oscillator and Clock Generation..... | 23 |
| 1.7.2 | Power Supply Management | 26 |
| 1.7.3 | Power ON/OFF | 27 |
| 1.7.4 | Power Control Modes | 28 |
| 1.7.5 | Interrupts..... | 35 |
| 1.7.6 | UART | 42 |
| 1.7.7 | Timers and Counters | 47 |
| 1.7.8 | WD Timer (Software Watchdog Timer) | 49 |
| 1.7.9 | User (USR) Ports..... | 52 |
| 1.7.10 | Real-Time Clock with Hardware Watchdog (RTC)..... | 54 |
| 1.7.11 | Analog Voltage Comparator | 57 |
| 1.7.12 | LED Driver | 59 |
| 1.7.13 | I ² C Master Interface..... | 60 |
| 1.7.14 | Keypad Interface..... | 67 |
| 1.7.15 | Emulator Port..... | 74 |
| 1.7.16 | USB Interface | 75 |
| 1.7.17 | Smart Card Interface Function | 78 |
| 1.7.18 | VDD Fault Detect Function..... | 113 |
| 2 | Application Schematics | 114 |
| 2.1 | Typical Application Schematic 1 | 114 |
| 2.2 | Typical Application Schematic 2 | 115 |
| 3 | Electrical Specification | 116 |
| 3.1 | Absolute Maximum Ratings | 116 |
| 3.2 | Recommended Operating Conditions | 116 |
| 3.3 | Digital IO Characteristics | 117 |
| 3.4 | Oscillator Interface Requirements | 118 |
| 3.5 | DC Characteristics: Analog Input | 118 |
| 3.6 | USB Interface Requirements | 119 |
| 3.7 | Smart Card Interface Requirements..... | 121 |
| 3.8 | DC Characteristics..... | 123 |
| 3.9 | Current Fault Detection Circuits | 125 |
| 4 | Equivalent Circuits | 126 |
| 4.1 | Package Pin Designation (68-Pin QFN)..... | 135 |
| 4.2 | Packaging Information | 136 |
| 5 | Ordering Information | 137 |
| 6 | Related Documentation | 137 |
| 7 | Contact Information | 137 |
| | Revision History | 138 |

Figures

| | |
|---|-----|
| Figure 1: IC Functional Block Diagram | 7 |
| Figure 2: Memory Map | 15 |
| Figure 3: Clock Generation and Control Circuits | 23 |
| Figure 4: Oscillator Circuit..... | 25 |
| Figure 5: Detailed Power Management Logic Block Diagram | 26 |
| Figure 6: Power-Down Control..... | 29 |
| Figure 7: Detail of Power-Down Interrupt Logic..... | 30 |
| Figure 8: Power-Down Sequencing | 30 |
| Figure 9: External Interrupt Configuration..... | 35 |
| Figure 10: Real Time Clock Block Diagram..... | 54 |
| Figure 11: I ² C Write Mode Operation..... | 61 |
| Figure 12: I ² C Read Operation | 62 |
| Figure 13: Simplified Keypad Block Diagram | 67 |
| Figure 14: Keypad Interface Flow Chart..... | 69 |
| Figure 15: USB Block Diagram | 75 |
| Figure 16: Smart Card Interface Block Diagram..... | 78 |
| Figure 17: Smart Card Interface Block Diagram..... | 79 |
| Figure 18: Asynchronous Activation Sequence Timing | 81 |
| Figure 19: Deactivation Sequence..... | 82 |
| Figure 20: Smart Card CLK and ETU Generation | 83 |
| Figure 21: Guard, Block, Wait and ATR Time Definitions | 84 |
| Figure 22: Synchronous Activation | 86 |
| Figure 23: Example of Sync Mode Operation: Generating/Reading ATR Signals | 86 |
| Figure 24: Creation of Synchronous Clock Start/Stop Mode Start Bit in Sync Mode | 87 |
| Figure 25: Creation of Synchronous Clock Start/Stop Mode Stop Bit in Sync Mode | 87 |
| Figure 26: Operation of 9-bit Mode in Sync Mode | 88 |
| Figure 27: 73S1217F Typical Application Schematic (Handheld USB PINpad, with Combo USB-Bus and Self-powered Configuration)..... | 114 |
| Figure 28: 73S1217F Typical Application Schematic (USB Transparent Reader and USB Key Configuration)..... | 115 |
| Figure 29: 12 MHz Oscillator Circuit | 126 |
| Figure 30: 32KHz Oscillator Circuit..... | 126 |
| Figure 31: Digital I/O Circuit..... | 127 |
| Figure 32: Digital Output Circuit..... | 127 |
| Figure 33: Digital I/O with Pull Up Circuit..... | 128 |
| Figure 34: Digital I/O with Pull Down Circuit | 128 |
| Figure 35: Digital Input Circuit..... | 129 |
| Figure 36: OFF_REQ Interface Circuit | 129 |
| Figure 37: Keypad Row Circuit | 130 |
| Figure 38: Keypad Column Circuit..... | 130 |
| Figure 39: LED Circuit..... | 131 |
| Figure 40: Test and Security Pin Circuit | 131 |
| Figure 41: Analog Input Circuit | 132 |
| Figure 42: Smart Card Output Circuit | 132 |
| Figure 43: Smart Card I/O Circuit | 133 |
| Figure 44: PRES Input Circuit..... | 133 |
| Figure 45: USB Circuit | 134 |
| Figure 46: ON_OFF Input Circuit..... | 134 |
| Figure 47: 73S1217F Pinout | 135 |
| Figure 48: 73S1217F 68 QFN Mechanical Drawing..... | 136 |

Tables

| | |
|---|----|
| Table 1: 73S1217 Pinout Description | 8 |
| Table 2: MPU Data Memory Map | 11 |
| Table 3: Flash Special Function Registers | 13 |
| Table 4: Internal Data Memory Map | 14 |
| Table 5: Program Security Registers | 17 |
| Table 6: IRAM Special Function Registers Locations | 18 |
| Table 7: IRAM Special Function Registers Reset Values | 19 |
| Table 8: XRAM Special Function Registers Reset Values | 20 |
| Table 9: PSW Register Flags..... | 22 |
| Table 10: Port Registers | 22 |
| Table 11: Frequencies and Mcount Values for MCLK = 96MHz | 24 |
| Table 12: The MCLKCtl Register | 24 |
| Table 13: The MPUCKCtl Register | 25 |
| Table 14: The INT5Ctl Register | 31 |
| Table 15: The MISCtl0 Register..... | 31 |
| Table 16: The MISCtl1 Register..... | 32 |
| Table 17: The MCLKCtl Register | 33 |
| Table 18: The PCON Register | 34 |
| Table 19: The IEN0 Register | 36 |
| Table 20: The IEN1 Register | 37 |
| Table 21: The IEN2 Register | 37 |
| Table 22: The TCON Register | 38 |
| Table 23: The T2CON Register | 38 |
| Table 24: The IRCON Register | 39 |
| Table 25: External MPU Interrupts..... | 39 |
| Table 26: Control Bits for External Interrupts..... | 40 |
| Table 27: Priority Level Groups | 40 |
| Table 28: The IP0 Register | 40 |
| Table 29: The IP1 Register | 41 |
| Table 30: Priority Levels..... | 41 |
| Table 31: Interrupt Polling Sequence..... | 41 |
| Table 32: Interrupt Vectors | 41 |
| Table 33: UART Modes | 42 |
| Table 34: Baud Rate Generation | 42 |
| Table 35: The PCON Register | 43 |
| Table 36: The BRCON Register | 43 |
| Table 37: The MISCtl0 Register..... | 44 |
| Table 38: The S0CON Register | 45 |
| Table 39: The S1CON Register | 46 |
| Table 40: The TMOD Register..... | 47 |
| Table 41: Timers/Counters Mode Description | 48 |
| Table 42: The TCON Register | 49 |
| Table 43: The IEN0 Register | 50 |
| Table 44: The IEN1 Register | 50 |
| Table 45: The IP0 Register | 51 |
| Table 46: The WDTREL Register | 51 |
| Table 47: Direction Registers and Internal Resources for DIO Pin Groups | 52 |
| Table 48: UDIR Control Bit | 52 |
| Table 49: Selectable Controls Using the UxIS Bits..... | 52 |
| Table 50: The USRIntCtl1 Register | 53 |
| Table 51: The USRIntCtl2 Register | 53 |
| Table 52: The USRIntCtl3 Register | 53 |
| Table 53: The USRIntCtl4 Register | 53 |
| Table 54: The RTCCtl Register..... | 55 |
| Table 55: The 32-bit RTC Counter..... | 56 |
| Table 56: The 24-bit RTC Accumulator | 56 |
| Table 57: The 24-bit RTC Trim (sign magnitude value) | 56 |

| | |
|--|-----|
| Table 58: The INT5Ctl Register | 56 |
| Table 59: The ACOMP Register | 57 |
| Table 60: The INT6Ctl Register | 58 |
| Table 61: The LEDCtl Register | 59 |
| Table 62: The DAR Register | 63 |
| Table 63: The WDR Register | 63 |
| Table 64: The SWDR Register | 64 |
| Table 65: The RDR Register | 64 |
| Table 66: The SRDR Register | 65 |
| Table 67: The CSR Register | 65 |
| Table 68: The INT6Ctl Register | 66 |
| Table 69: The KCOL Register | 70 |
| Table 70: The KROW Register | 70 |
| Table 71: The KSCAN Register | 71 |
| Table 72: The KSTAT Register | 72 |
| Table 73: The KSIZE Register | 73 |
| Table 74: The KORDERL Register | 73 |
| Table 75: The KORDERH Register | 74 |
| Table 76: The INT5Ctl Register | 74 |
| Table 77: The MISCTl1 Register | 76 |
| Table 78: The CKCON Register | 77 |
| Table 79: The SCSel Register | 89 |
| Table 80: The SCInt Register | 90 |
| Table 81: The SCIE Register | 91 |
| Table 82: The VccCtl Register | 92 |
| Table 83: The VccTmr Register | 93 |
| Table 84: The CRDCtl Register | 94 |
| Table 85: The STXCtl Register | 95 |
| Table 86: The STXData Register | 96 |
| Table 87: The SRXCtl Register | 97 |
| Table 88: The SRXData Register | 98 |
| Table 89: The SCCTl Register | 99 |
| Table 90: The SCECtl Register | 100 |
| Table 91: The SCDIR Register | 101 |
| Table 92: The SPrtcol Register | 102 |
| Table 93: The SCCLK Register | 103 |
| Table 94: The SCECLK Register | 103 |
| Table 95: The SParCtl Register | 104 |
| Table 96: The SByteCtl Register | 105 |
| Table 97: The FDReg Register | 106 |
| Table 98: Divider Ratios Provided by the ETU Counter | 106 |
| Table 99: Divider Values for the ETU Clock | 107 |
| Table 100: The CRCMSB Register | 108 |
| Table 101: The CRCLsB Register | 108 |
| Table 102: The BGT Register | 109 |
| Table 103: The EGT Register | 109 |
| Table 104: The BWTB0 Register | 110 |
| Table 105: The BWTB1 Register | 110 |
| Table 106: The BWTB2 Register | 110 |
| Table 107: The BWTB3 Register | 110 |
| Table 108: The CWTB0 Register | 110 |
| Table 109: The CWTB1 Register | 110 |
| Table 110: The ATRLsB Register | 111 |
| Table 111: The ATRMsB Register | 111 |
| Table 112: The STSTO Register | 111 |
| Table 113: The RLength Register | 111 |
| Table 114: Smart Card SFR Table | 112 |
| Table 115: The VDDFctl Register | 113 |
| Table 116: Order Numbers and Packaging Marks | 137 |

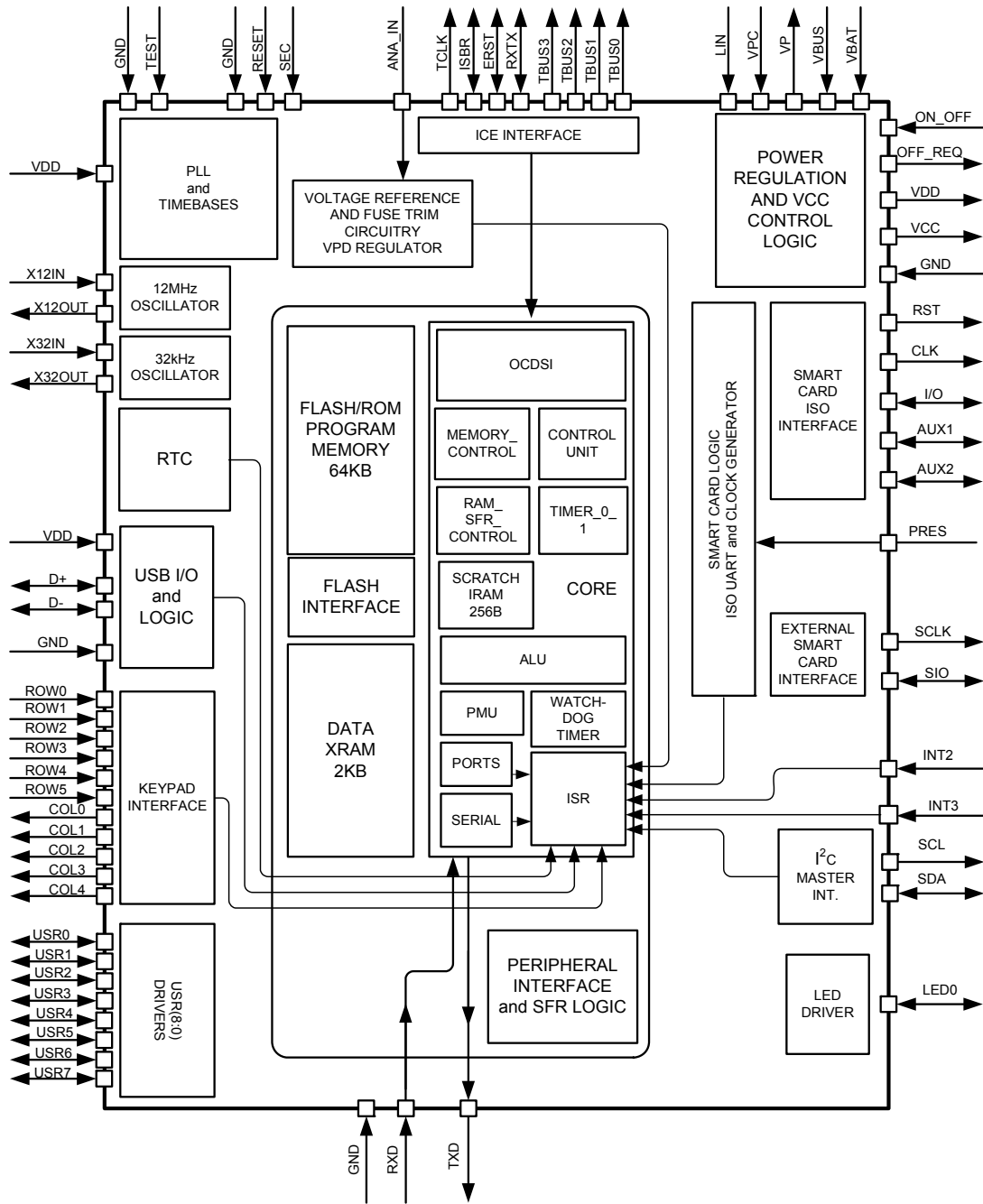

Figure 1: IC Functional Block Diagram

1 Hardware Description

1.1 Pin Description

Table 1: 73S1217 Pinout Description

| Pin Name | Pin (68 QFN) | Type | Equivalent Circuit* | Description |
|---|--|------|---------------------------|---|
| X12IN | 10 | I | Figure 29 | MPU/USB clock crystal oscillator input pin. A 12MHz crystal is required for USB operation. A 1M Ω resistor is required between pins X12IN and X12OUT. |
| X12OUT | 11 | O | Figure 29 | MPU/USB clock crystal oscillator output pin. |
| X32IN | 8 | I | Figure 30 | RTC clock crystal oscillator input pin. A 32768Hz crystal is required for low-power RTC operation. |
| X32OUT | 7 | O | Figure 30 | RTC clock crystal oscillator output pin. |
| DP | 26 | IO | Figure 45 | USB D+ IO pin, requires series 24 Ω resistor. |
| DM | 27 | IO | Figure 45 | USB D- IO pin, requires series 24 Ω resistor. |
| ROW(5:0) 0 1 2 3 4 5 | 21 22 24 33 36 37 | I | Figure 37 | Keypad row input sense. |
| COL(4:0) 0 1 2 3 4 | 12 13 14 16 19 | O | Figure 38 | Keypad column output scan pins. |
| USR(7:0) 0 1 2 3 4 5 6 7 | 35 34 32 31 30 29 23 20 | IO | Figure 33 | General-purpose user pins, individually configurable as inputs or outputs or as external input interrupt ports. |
| SCL | 5 | O | Figure 32 | I ² C (master mode) compatible Clock signal. Note: the pin is configured as an open drain output. When the I2C interface is being used, an external pull up resistor is required. A value of 3K is recommended. |
| SDA | 6 | IO | Figure 31 | I ² C (master mode) compatible data I/O. Note: this pin is bi-directional. When the pin is configured as output, it is an open drain output. When the I2C interface is being used, an external pull up resistor is required. A value of 3K is recommended. |
| RXD | 17 | I | Figure 35 | Serial UART Receive data pin. |
| TXD | 18 | O | Figure 32 | Serial UART Transmit data pin. |

| Pin Name | Pin (68 QFN) | Type | Equivalent Circuit* | Description |
|----------|--------------|------|---------------------------|---|
| INT3 | 48 | I | Figure 35 | General purpose interrupt input. |
| INT2 | 49 | I | Figure 35 | General purpose interrupt input. |
| SIO | 47 | IO | Figure 31 | IO data signal for use with external Smart Card interface circuit such as 73S73S8010x. |
| SCLK | 45 | O | Figure 32 | Clock signal for use with external Smart Card interface circuit. |
| PRES | 53 | I | Figure 44 | Smart Card presence. Active high. Note: the pin has a very weak pull down resistor. In noisy environments, an external pull down may be desired to insure against a false card event. |
| CLK | 55 | O | Figure 42 | Smart card clock signal. |
| RST | 57 | O | Figure 42 | Smart card Reset signal. |
| IO | 61 | IO | Figure 43 | Smart card Data IO signal. |
| AUX1 | 60 | IO | Figure 43 | Auxiliary Smart Card IO signal (C4). |
| AUX2 | 59 | IO | Figure 43 | Auxiliary Smart Card IO signal (C8). |
| VCC | 58 | PSO | | Smart Card VCC supply voltage output. A 0.47 μ F capacitor is required and should be located at the smart card connector. The capacitor should be a ceramic type with low ESR. |
| GND | 56 | GND | | Smart Card Ground. |
| VPC | 65 | PSI | | Power supply source for main voltage converter circuit. A 10 μ F and a 0.1 μ F capacitor are required at the VPC input. The 10 μ F capacitor should be a ceramic type with low ESR. |
| VBUS | 62 | PSI | | Alternate power source input from USB connector or hub. |
| VBAT | 64 | PSI | | Alternate power source input, typically from two series cells, V > 4V. |
| VP | 54 | PSO | | Intermediate output of main converter circuit. Requires an external 4.7 μ F low ESR filter capacitor to GND. |
| LIN | 66 | PSI | | Connection to 10 μ H inductor for internal step up converter. Note: inductor must be rated for 400 mA maximum peak current. |
| ON_OFF | 63 | I | Figure 46 | Power control pin. Connected to normally open SPST switch to ground. Closing switch for duration greater than de-bounce period will turn 73S1217F on. If 73S1217F is on, closing switch will flag the 73S1217F to go to the off state. Firmware will control when the power is shut down. |

| Pin Name | Pin (68 QFN) | Type | Equivalent Circuit* | Description |
|---------------------------|----------------------|------|---------------------------|--|
| OFF_REQ | 52 | O | Figure 36 | Digital output. If ON_OFF switch is closed (to ground) for de-bounce duration and circuit is “on,” OFF_REQ will go high (Request to turn OFF). This output should be connected to an interrupt pin to signal the CPU core that a request to shut down power has been initiated. The firmware can then perform all of its shut down housekeeping duties before shutting down V_{DD} . |
| TBUS(3:0)0 1 2 3 | 50 46 44 41 | IO | | Trace bus signals for ICE. |
| RXTX | 43 | IO | | ICE control. |
| ERST | 38 | IO | | ICE control. |
| ISBR | 3 | IO | | ICE control. |
| TCLK | 39 | I | | ICE control. |
| ANA_IN | 15 | AI | Figure 41 | Analog input pin. This signal goes to a programmable comparator and is used to sense the value of an external voltage. |
| LED0 | 4 | IO | Figure 39 | Special output driver, programmable pull-down current to drive LED. May also be used as an input. |
| SEC | 2 | I | Figure 40 | Input pin for use in programming security fuse. It should be connected to ground when not in use. |
| TEST | 51 | DI | Figure 40 | Test pin, should be connected to ground. |
| VDD | 68 28 40 | PSO | | V_{DD} supply output pin. A 0.1 μ F capacitor is recommended at each VDD pin. |
| GND | 9 25 42 67 | GND | | General ground supply pins for all IO and logic circuits. |
| RESET | 1 | I | Figure 35 | Reset input, positive assertion. Resets logic and registers to default condition. Note: to insure proper reset operation after V_{DD} is turned on by application of V_{BUS} power or activation of the ON/OFF switch, external reset circuitry must generate a proper reset signal to the 73S1217F. This can be accomplished via a simple RC network. |

* See the figures in the [Equivalent Circuits](#) section.

1.2 Hardware Overview

The 73S1217F single smart card controller integrates all primary functional blocks required to implement a smart card reader with host serial and / or USB interface. Included on chip are an 8051-compatible microprocessor (MPU) which executes up to one instruction per clock cycle (80515), a fully integrated ISO 7816 compliant smart card interface, expansion smart card interface, full speed USB 2.0 compatible interface, serial interface, I2C interface, 6 x 5 keypad interface, RAM, FLASH memory, a real time clock (RTC), and a variety of I/O pins.

Advanced power management features include a DC-DC converter and on-chip regulators that generate all the necessary voltages for the circuit: Primarily a smart card supply VCC, (selectable to 1.8V, 3V or 5V) and a 3.3V digital voltage output (VDD, pin #68) that must be connected to the power supply inputs of the digital core of the circuit, pins # 28 and 40 (these are not internally connected). Should external circuitry require a 3.3V digital power supply, the VDD output is capable of supplying additional current. The whole IC can be powered up either from a USB bus-power supply (VBUS +5V typical), or from a typical set of battery cells VBAT. Automated switching between these supply inputs give the priority to VBUS to save the battery life.

A functional block diagram of the 73S1217F is shown in [Figure 1](#).

1.3 80515 MPU Core

1.3.1 80515 Overview

The 73S1217F includes an 80515 MPU (8-bit, 8051-compatible) that performs most instructions in one clock cycle. The 80515 architecture eliminates redundant bus states and implements parallel execution of fetch and execution phases. Normally a machine cycle is aligned with a memory fetch, therefore, most of the 1-byte instructions are performed in a single cycle. This leads to an 8x performance (average) improvement (in terms of MIPS) over the Intel 8051 device running at the same clock frequency.

Actual processor clocking speed can be adjusted to the total processing demand of the application (cryptographic calculations, key management, memory management, and I/O management) using the XRAM special function register [MPUCKCtl](#).

Typical smart card, USB, serial, keyboard, I2C and RTC management functions are available for the MPU as part of the Teridian standard library. A standard ANSI "C" 80515-application programming interface library is available to help reduce design cycle. Refer to the *73S12xxF Software User's Guide*.

1.3.2 Memory Organization

The 80515 MPU core incorporates the Harvard architecture with separate code and data spaces. Memory organization in the 80515 is similar to that of the industry standard 8051. There are three memory areas: Program memory (Flash), external data memory (XRAM), and internal data memory (IRAM). Data bus address space is allocated to on-chip memory as shown Table 2.

Table 2: MPU Data Memory Map

| Address (hex) | Memory Technology | Memory Type | Typical Usage | Memory Size (bytes) |
|---------------|-------------------|--------------|-------------------------------|---------------------|
| 0000-FFFF | Flash Memory | Non-volatile | Program and non-volatile data | 64KB |
| 0000-07FF | Static RAM | Volatile | MPU data XRAM | 2KB |
| FC00-FFFF | External SFR | Volatile | Peripheral control | 1KB |

Note: The IRAM is part of the core and is addressed differently.

Program Memory: The 80515 can address up to 64KB of program memory space from 0x0000 to 0xFFFF. Program memory is read when the MPU fetches instructions or performs a MOVC operation. After reset, the MPU starts program execution from location 0x0000. The lower part of the program memory includes reset and interrupt vectors. The interrupt vectors are spaced at 8-byte intervals, starting from 0x0003. Reset is located at 0x0000.

Flash Memory: The program memory consists of flash memory. The flash memory is intended to primarily contain MPU program code. Flash erasure is initiated by writing a specific data pattern to specific SFR registers in the proper sequence. These special pattern/sequence requirements prevent inadvertent erasure of the flash memory.

The mass erase sequence is:

1. Write 1 to the FLSH_MEEN bit in the **FLSHCTL** register (SFR address 0xB2[1]).
2. Write pattern 0xAA to **ERASE** (SFR address 0x94)

Note: The mass erase cycle can only be initiated when the ICE port is enabled.

The page erase sequence is:

1. Write the page address to **PGADDR** (SFR address 0xB7[7:1])
2. Write pattern 0x55 to **ERASE** (SFR address 0x94)

The PGADDR register denotes the page address for page erase. The page size is 512 (200h) bytes and there are 128 pages within the flash memory. The **PGADDR** denotes the upper seven bits of the flash memory address such that bit 7:1 of the **PGADDR** corresponds to bit 15:9 of the flash memory address. Bit 0 of the PGADDR is not used and is ignored. The MPU may write to the flash memory. This is one of the non-volatile storage options available to the user. The **FLSHCTL** SFR bit FLSH_PWE (flash program write enable) differentiates 80515 data store instructions (MOVX@DPTR,A) between Flash and XRAM writes. Before setting FLSH_PWE, all interrupts need to be disabled by setting EAL = 1. Table 3 shows the location and description of the 73S1217F flash-specific SFRs.

- ✓ Any flash modifications must set the CPUCLK to operate at 3.6923 MHz (**MPUCLKCt** = 0x0C) before any flash memory operations are executed to insure the proper timing when modifying the flash memory.

Table 3: Flash Special Function Registers

| Register | SFR Address | R/W | Description |
|----------|-------------|-----|--|
| ERASE | 0x94 | W | <p>This register is used to initiate either the Flash Mass Erase cycle or the Flash Page Erase cycle. Specific patterns are expected for ERASE in order to initiate the appropriate Erase cycle (default = 0x00).</p> <p>0x55 – Initiate Flash Page Erase cycle. Must be preceded by a write to PGADDR @ SFR 0xB7.</p> <p>0xAA – Initiate Flash Mass Erase cycle. Must be preceded by a write to FLSH_MEEN @ SFR 0xB2 and the debug port must be enabled.</p> <p>Any other pattern written to ERASE will have no effect.</p> |
| PGADDR | 0xB7 | R/W | <p>Flash Page Erase Address register containing the flash memory page address (page 0 through 127) that will be erased during the Page Erase cycle (default = 0x00). Note: the page address is shifted left by one bit (see detailed description above).</p> <p>Must be re-written for each new Page Erase cycle.</p> |
| FLSHCTL | 0xB2 | R/W | <p>Bit 0 (FLSH_PWE): Program Write Enable:</p> <p>0 – MOVX commands refer to XRAM Space, normal operation (default). 1 – MOVX @DPTR,A moves A to Program Space (Flash) @ DPTR.</p> <p>This bit is automatically reset after each byte written to flash. Writes to this bit are inhibited when interrupts are enabled.</p> |
| | | W | <p>Bit 1 (FLSH_MEEN): Mass Erase Enable:</p> <p>0 – Mass Erase disabled (default). 1 – Mass Erase enabled.</p> <p>Must be re-written for each new Mass Erase cycle.</p> |
| | | R/W | <p>Bit 6 (SECURE):</p> <p>Enables security provisions that prevent external reading of flash memory and CE program RAM. This bit is reset on chip reset and may only be set. Attempts to write zero are ignored.</p> |

Internal Data Memory: The internal data memory provides 256 bytes (0x00 to 0xFF) of data memory. The internal data memory address is always one byte wide and can be accessed by either direct or indirect addressing. The Special Function Registers occupy the upper 128 bytes. **This SFR area is available only by direct addressing. Indirect addressing accesses the upper 128 bytes of Internal RAM.**

The lower 128 bytes contain working registers and bit-addressable memory. The lower 32 bytes form four banks of eight registers (R0-R7). Two bits on the program memory status word (PSW) select which bank is in use. The next 16 bytes form a block of bit-addressable memory space at bit addresses 0x00-0x7F. All of the bytes in the lower 128 bytes are accessible through direct or indirect addressing. Table 4 shows the internal data memory map.

Table 4: Internal Data Memory Map

| Addresses | Direct Addressing | Indirect Addressing |
|-----------|-----------------------------------|---------------------|
| 0xFF | Special Function Registers (SFRs) | RAM |
| 0x80 | | |
| 0x7F | Byte-addressable area | |
| 0x30 | | |
| 0x2F | Byte or bit-addressable area | |
| 0x20 | | |
| 0x1F | Register banks R0...R7 (x4) | |
| 0x00 | | |

External Data Memory: While the 80515 can address up to 64KB of external data memory in the space from 0x0000 to 0xFFFF, only the memory ranges shown in Figure 2 contain physical memory. The 80515 writes into external data memory when the MPU executes a `MOVX @Ri,A` or `MOVX @DPTR,A` instruction. The MPU reads external data memory by executing a `MOVX A,@Ri` or `MOVX A,@DPTR` instruction.

There are two types of instructions, differing in whether they provide an eight-bit or sixteen-bit indirect address to the external data RAM.

In the first type (`MOVX A,@Ri`), the contents of R0 or R1, in the current register bank, provide the eight lower-ordered bits of address. This method allows the user access to the first 256 bytes of the 2KB of external data RAM. In the second type of `MOVX` instruction (`MOVX A,@DPTR`), the data pointer generates a sixteen-bit address.

| Address | Use | Address | Use |
|-----------------------|-----------------------------------|-----------------------------|-------------------------------------|
| 0xFFFF | Flash Program Memory 64K Bytes | 0xFFFF | Peripheral Control Registers (128b) |
| | | 0xFF80 | |
| | | 0xFF7F | Smart Card Control (384b) |
| | | 0xFE00 | |
| | | 0xFDFF | USB Registers (512b) |
| | | 0xFC00 | |
| | | 0xFBFF | - |
| | | 0x0800 | |
| | | 0x07FF | XRAM |
| | | | |
| | | | |
| | | | |
| | | | |
| | | | |
| | | | |
| | | | |
| | | | |
| 0x0000 | | 0x0000 | |
| Program Memory | | External Data Memory | |

| Address | Use | |
|-----------------------------|-----------------|---------------|
| | Indirect Access | Direct Access |
| 0xFF | Byte RAM | SFRs |
| 0x80 | | |
| 0x7F | Byte RAM | |
| 0x48 | | |
| 0x47 | Bit/Byte RAM | |
| 0x20 | | |
| 0x1F | Register bank 3 | |
| 0x18 | | |
| 0x17 | Register bank 2 | |
| 0x10 | | |
| 0x0F | Register bank 1 | |
| 0x08 | | |
| 0x07 | Register bank 0 | |
| 0x00 | | |
| Internal Data Memory | | |

Figure 2: Memory Map

Dual Data Pointer: The Dual Data Pointer accelerates the block moves of data. The standard DPTR is a 16-bit register that is used to address external memory. In the 80515 core, the standard data pointer is called DPTR, the second data pointer is called DPTR1. The data pointer select bit chooses the active pointer. The data pointer select bit is located at the LSB of the DPS IRAM special function register (DPS.0). DPTR is selected when DPS.0 = 0 and DPTR1 is selected when DPS.0 = 1.

The user switches between pointers by toggling the LSB of the DPS register. All DPTR-related instructions use the currently selected DPTR for any activity.

Note: The second data pointer may not be supported by certain compilers.

1.4 Program Security

Two levels of program and data security are available. Each level requires a specific fuse to be blown in order to enable or set the specific security mode. Mode 0 security is enabled by setting the SECURE bit (bit 6 of SFR register [FLSHCTL 0xB2](#)). Mode 0 limits the ICE interface to only allow bulk erase of the flash program memory. All other ICE operations are blocked. This guarantees the security of the user's MPU program code. Security (Mode 0) is enabled by MPU code that sets the SECURE bit. The MPU code must execute the setting of the SECURE bit immediately after a reset to properly enable Mode 0. This should be the first instruction after the reset vector jump has been executed. If the "startup.a51" assembly file is used in an application, then it must be modified to set the SECURE bit after the reset vector jump. If not using "startup.a51", then this should be the first instruction in main(). Once security Mode 0 is enabled, the only way to disable it is to perform a global erase of the flash followed by a full circuit reset. Once the flash has been erased and the reset has been executed, security Mode 0 is disabled and the ICE has full control of the core. The flash can be reprogrammed after the bulk erase operation is completed. Global erase of the flash will also clear the data XRAM memory.

The security enable bit (SECURE) is reset whenever the MPU is reset. Hardware associated with the bit only allows it to be set. As a result, the code may set the SECURE bit to enable the security Mode 0 feature but may not reset it. Once the SECURE bit is set, the code is protected and no external read of program code in flash or data (in XRAM) is possible. In order to invoke the security Mode 0, the SECSET0 (bit 1 of XRAM SFR register [SECReg 0xFFD7](#)) fuse must be blown beforehand or the security mode 0 will not be enabled. The SECSET0 and SECSET1 fuses once blown, cannot be overridden.

Specifically, when SECURE is set:

- The ICE is limited to bulk flash erase only.
- Page zero of flash memory may not be page-erased by either MPU or ICE. Page zero may only be erased with global flash erase. Note that global flash erase erases XRAM whether the SECURE bit is set or not.
- Writes to page zero, whether by MPU or ICE, are inhibited.

Security mode 1 is in effect when the SECSET1 fuse has been programmed (blown open). In security mode 1, the ICE is completely and permanently disabled. The Flash program memory and the MPU are not available for alteration, observation, nor control. As soon as the fuse has been blown, the ICE is disabled. The testing of the SECSET1 fuse will occur during the reset and before the start of pre-boot and boot cycles. This mode is not reversible, nor recoverable. In order to blow the SECSET1 fuse, the SEC pin must be held high for the fuse burning sequence to be executed properly. The firmware can check to see if this pin is held high by reading the SECPIN bit (bit 5 of XRAM SFR register [SECReg 0xFFD7](#)). If this bit is set and the firmware desires, it can blow the SECSET1 fuse. The burning of the SECSET0 does not require the SEC pin to be held high.

In order to blow the fuse for SECSET1 and SECSET0, a particular set of register writes in a specific order need to be followed. There are two additional registers that need to have a specific value written to them in order for the desired fuse to be blown. These registers are [FUSECtI](#) (0xFFD2) and [TRIMPcI](#) (0xFFD1). The sequence for blowing the fuse is as follows:

1. Write 0x54H to [FUSECtI](#).
2. Write 0x81H for security mode 0 Note: only program one security mode at a time.
3. Write 0x82H for security mode 1 Note: SEC pin must be high for security mode 1.
4. Write 0xA6 to [TRIMPcI](#).
5. Delay about 500 us
6. Write 0x00 to [TRIMPcI](#) and [FUSECtI](#).

Table 5: Program Security Registers

| Register | SFR Address | R/W | Description |
|----------|-------------|-----|---|
| FLSHCTL | 0xB2 | R/W | Bit 0 (FLSH_PWE): Program Write Enable: 0 – MOVX commands refer to XRAM Space, normal operation (default). 1 – MOVX @DPTR,A moves A to Program Space (Flash) @ DPTR. This bit is automatically reset after each byte written to flash. Writes to this bit are inhibited when interrupts are enabled. |
| | | W | Bit 1 (FLSH_MEEN): Mass Erase Enable: 0 – Mass Erase disabled (default). 1 – Mass Erase enabled. Must be re-written for each new Mass Erase cycle. |
| | | R/W | Bit 6 (SECURE): Enables security provisions that prevent external reading of flash memory and CE program RAM. This bit is reset on chip reset and may only be set. Attempts to write zero are ignored. |
| TRIMPCTl | 0xFFD1 | W | 0xA6 value will cause the selected fuse to be blown. All other values will stop the burning process. |
| FUSECtI | 0xFFD2 | W | 0x54 value will set up for security fuse control. All other values are reserved and should not be used. |
| SECReg | 0xFFD7 | W | Bit 7 (PARAMSEC): 0 – Normal operation. 1 – Enable permanent programming of the security fuses. |
| | | R | Bit 5 (SECPIN): Indicates the state of the SEC pin. The SEC pin is held low by a pull-down resistor. The user can force this pin high during boot sequence time to indicate to firmware that sec mode 1 is desired. |
| | | R/W | Bit 1 (SECSET1): See the Program Security section. |
| | | R/W | Bit 0 (SECSET0): See the Program Security section. |

1.5 Special Function Registers (SFRs)

The 1217 utilizes numerous SFRs to communicate with the many 1217 peripherals. This results in the need for more SFR locations outside the direct address IRAM space (0x80 to 0xFF). While some peripherals are mapped to unused IRAM SFR locations, additional SFRs for the USB, smart card and other peripheral functions are mapped to the top of the XRAM data space (0xFC00 to 0xFFFF).

1.5.1 Internal Data Special Function Registers (SFRs)

The Special Function Registers map is shown in Table 6.

Table 6: IRAM Special Function Registers Locations

| Hex\Bin | X000 | X001 | X010 | X011 | X100 | X101 | X110 | X111 | Bin/ Hex |
|---------|--------------|---------------|----------------|---------------|--------------|---------------|----------------|----------------|-------------|
| F8 | | | | | | | | | FF |
| F0 | B | | | | | | | | F7 |
| E8 | | | | | | | | | EF |
| E0 | A | | | | | | | | E7 |
| D8 | BRCON | | | | | | | | DF |
| D0 | PSW | KCOL | KROW | KSCAN | KSTAT | KSIZE | KORDERL | KORDERH | D7 |
| C8 | T2CON | | | | | | | | CF |
| C0 | IRCON | | | | | | | | C7 |
| B8 | IEN1 | IP1 | S0RELH | S1RELH | | | | | BF |
| B0 | | | FLSHCTL | | | | | PGADDR | B7 |
| A8 | IEN0 | IP0 | S0RELL | | | | | | AF |
| A0 | | | | | | | | | A7 |
| 98 | S0CON | S0BUF | IEN2 | S1CON | S1BUF | S1RELL | | | 9F |
| 90 | USR70 | UDIR70 | DPS | | ERASE | | | | 97 |
| 88 | TCON | TMOD | TL0 | TL1 | TH0 | TH1 | | MCLKCtl | 8F |
| 80 | | SP | DPL | DPH | DPL1 | DPH1 | WDTREL | PCON | 87 |

Only a few addresses are used, the others are not implemented. SFRs specific to the 73S1217F are shown in **bold** print (gray background). Any read access to unimplemented addresses will return undefined data, while most write access will have no effect. However, a few locations are reserved and not user configurable in the 73S1217F. **Writes to the unused SFR locations can affect the operation of the core and therefore must not be written to. This applies to all the SFR areas in both the IRAM and XRAM spaces. In addition, all unused bit locations within valid SFR registers must be left in their default (power on default) states.**

1.5.2 IRAM Special Function Registers (Generic 80515 SFRs)

Table 7 shows the location of the SFRs and the value they assume at reset or power-up.

Table 7: IRAM Special Function Registers Reset Values

| Name | Location | Reset Value | Description |
|---------|----------|-------------|---|
| SP | 0x81 | 0x07 | Stack Pointer |
| DPL | 0x82 | 0x00 | Data Pointer Low 0 |
| DPH | 0x83 | 0x00 | Data Pointer High 0 |
| DPL1 | 0x84 | 0x00 | Data Pointer Low 1 |
| DPH1 | 0x85 | 0x00 | Data Pointer High 1 |
| WDTRREL | 0x86 | 0x00 | Watchdog Timer Reload register |
| PCON | 0x87 | 0x00 | Power Control |
| TCON | 0x88 | 0x00 | Timer/Counter Control |
| TMOD | 0x89 | 0x00 | Timer Mode Control |
| TL0 | 0x8A | 0x00 | Timer 0, low byte |
| TL1 | 0x8B | 0x00 | Timer 1, high byte |
| TH0 | 0x8C | 0x00 | Timer 0, low byte |
| TH1 | 0x8D | 0x00 | Timer 1, high byte |
| MCLKCtI | 0x8F | 0x0A | Master Clock Control |
| USR70 | 0x90 | 0xFF | User Port Data (7:0) |
| UDIR70 | 0x91 | 0xFF | User Port Direction (7:0) |
| DPS | 0x92 | 0x00 | Data Pointer Select Register |
| ERASE | 0x94 | 0x00 | Flash Erase |
| S0CON | 0x98 | 0x00 | Serial Port 0, Control Register |
| S0BUF | 0x99 | 0x00 | Serial Port 0, Data Buffer |
| IEN2 | 0x9A | 0x00 | Interrupt Enable Register 2 |
| S1CON | 0x9B | 0x00 | Serial Port 1, Control Register |
| S1BUF | 0x9C | 0x00 | Serial Port 1, Data Buffer |
| S1RELL | 0x9D | 0x00 | Serial Port 1, Reload Register, low byte |
| IEN0 | 0xA8 | 0x00 | Interrupt Enable Register 0 |
| IP0 | 0xA9 | 0x00 | Interrupt Priority Register 0 |
| S0RELL | 0xAA | 0xD9 | Serial Port 0, Reload Register, low byte |
| FLSHCTL | 0xB2 | 0x00 | Flash Control |
| PGADDR | 0xB7 | 0x00 | Flash Page Address |
| IEN1 | 0xB8 | 0x00 | Interrupt Enable Register 1 |
| IP1 | 0xB9 | 0x00 | Interrupt Priority Register 1 |
| S0RELH | 0xBA | 0x03 | Serial Port 0, Reload Register, high byte |
| S1RELH | 0xBB | 0x03 | Serial Port 1, Reload Register, high byte |
| IRCON | 0xC0 | 0x00 | Interrupt Request Control Register |
| T2CON | 0xC8 | 0x00 | Timer 2 Control |
| PSW | 0xD0 | 0x00 | Program Status Word |
| KCOL | 0xD1 | 0x1F | Keypad Column |

| Name | Location | Reset Value | Description |
|---------|----------|-------------|--|
| KROW | 0XD2 | 0x3F | Keypad Row |
| KSCAN | 0XD3 | 0x00 | Keypad Scan Time |
| KSTAT | 0XD4 | 0x00 | Keypad Control/Status |
| KSIZE | 0XD5 | 0x00 | Keypad Size |
| KORDERL | 0XD6 | 0x00 | Keypad Column LS Scan Order |
| KORDERH | 0XD7 | 0x00 | Keypad Column MS Scan Order |
| BRCON | 0xD8 | 0x00 | Baud Rate Control Register (only BRCON.7 bit used) |
| A | 0xE0 | 0x00 | Accumulator |
| B | 0xF0 | 0x00 | B Register |

1.5.3 External Data Special Function Registers (SFRs)

A map of the XRAM Special Function Registers is shown in Table 8. The smart card registers are listed separately in Table 114.

Table 8: XRAM Special Function Registers Reset Values

| Name | Location | Reset Value | Description |
|------------|----------|-------------|--|
| DAR | 0x FF80 | 0x00 | Device Address Register (I ² C) |
| WDR | 0x FF81 | 0x00 | Write Data Register (I ² C) |
| SWDR | 0x FF82 | 0x00 | Secondary Write Data Register (I ² C) |
| RDR | 0x FF83 | 0x00 | Read Data Register (I ² C) |
| SRDR | 0x FF84 | 0x00 | Secondary Read Data Register (I ² C) |
| CSR | 0x FF85 | 0x00 | Control and Status Register (I ² C) |
| USRIntCtl1 | 0x FF90 | 0x00 | External Interrupt Control 1 |
| USRIntCtl2 | 0x FF91 | 0x00 | External Interrupt Control 2 |
| USRIntCtl3 | 0x FF92 | 0x00 | External Interrupt Control 3 |
| USRIntCtl4 | 0x FF93 | 0x00 | External Interrupt Control 4 |
| INT5Ctl | 0x FF94 | 0x00 | External Interrupt Control 5 |
| INT6Ctl | 0x FF95 | 0x00 | External Interrupt Control 6 |
| MPUCKCtl | 0x FFA1 | 0x0C | MPU Clock Control |
| RTCCtl | 0x FFB0 | 0x00 | Real Time Clock Control |
| RTCCnt3 | 0x FFB1 | 0x00 | RTC Count 3 |
| RTCCnt2 | 0x FFB2 | 0x00 | RTC Count 2 |
| RTCCnt1 | 0x FFB3 | 0x00 | RTC Count 1 |
| RTCCnt0 | 0x FFB4 | 0x00 | RTC Count 0 |
| RTCACC2 | 0x FFB5 | 0x00 | RTC Accumulator 2 |
| RTCACC1 | 0x FFB6 | 0x00 | RTC Accumulator 1 |
| RTCACC0 | 0x FFB7 | 0x00 | RTC Accumulator 0 |
| RTCTrim2 | 0x FFB8 | 0x00 | RTC TRIM 2 |
| RTCTrim1 | 0x FFB9 | 0x00 | RTC TRIM 1 |
| RTCTrim0 | 0x FFB A | 0x00 | RTC TRIM 0 |
| ACOMP | 0x FFD0 | 0x00 | Analog Compare Register |
| TRIMPCtl | 0x FFD1 | 0x00 | TRIM Pulse Control |

| Name | Location | Reset Value | Description |
|-------------------------|----------|-------------|----------------------------------|
| FUSECtl | 0x FFD2 | 0x00 | FUSE Control |
| VDDFCtl | 0x FFD4 | 0x00 | VDDFault Control |
| SECReg | 0x FFD7 | 0x00 | Security Register |
| MISCTl0 | 0x FFF1 | 0x00 | Miscellaneous Control Register 0 |
| MISCTl1 | 0x FFF2 | 0x10 | Miscellaneous Control Register 1 |
| LEDCtl | 0x FFF3 | 0xFF | LED Control Register |

Accumulator (ACC, A): ACC is the accumulator register. Most instructions use the accumulator to hold the operand. The mnemonics for accumulator-specific instructions refer to accumulator as “A”, not ACC.

B Register: The B register is used during multiply and divide instructions. It can also be used as a scratch-pad register to hold temporary data.

Program Status Word (PSW):**Table 9: PSW Register Flags**

| MSB | | | | LSB | | | | | | | | |
|-------|--------|---|-----|-----|--------|---------------|---|----------------|----------------------|-----------------|--|--|
| CV | AC | F0 | RS1 | RS | OV | – | P | | | | | |
| Bit | Symbol | Function | | | | | | | | | | |
| PSW.7 | CV | Carry flag. | | | | | | | | | | |
| PSW.6 | AC | Auxiliary Carry flag for BCD operations. | | | | | | | | | | |
| PSW.5 | F0 | General purpose Flag 0 available for user. | | | | | | | | | | |
| PSW.4 | RS1 | Register bank select control bits. The contents of RS1 and RS0 select the working register bank: | | | | | | | | | | |
| | | | | | | | | RS1/RS0 | Bank Selected | Location | | |
| | | | | | | | | 00 | Bank 0 | (0x00 – 0x07) | | |
| | | | | | | | | 01 | Bank 1 | (0x08 – 0x0F) | | |
| | | | | | | | | 10 | Bank 2 | (0x10 – 0x17) | | |
| PSW.3 | RS0 | | | 11 | Bank 3 | (0x18 – 0x1F) | | | | | | |
| PSW.2 | OV | Overflow flag. | | | | | | | | | | |
| PSW.1 | F1 | General purpose Flag 1 available for user. | | | | | | | | | | |
| PSW.0 | P | Parity flag, affected by hardware to indicate odd / even number of “one” bits in the Accumulator, i.e. even parity. | | | | | | | | | | |

Stack Pointer (SP): The stack pointer is a 1-byte register initialized to 0x07 after reset. This register is incremented before PUSH and CALL instructions, causing the stack to begin at location 0x08.

Data Pointer: The data pointer (DPTR) is 2 bytes wide. The lower part is DPL, and the highest is DPH. It can be loaded as a 2-byte register (MOV DPTR,#data16) or as two registers (e.g. MOV DPL,#data8). It is generally used to access external code or data space (e.g. MOVC A,@A+DPTR or MOVX A,@DPTR respectively).

Program Counter: The program counter (PC) is 2 bytes wide initialized to 0x0000 after reset. This register is incremented during the fetching operation code or when operating on data from program memory. Note: The program counter is not mapped to the SFR area.

Port Registers: The I/O ports are controlled by Special Function Register [USR70](#). The contents of the SFR can be observed on corresponding pins on the chip. Writing a 1 to any of the ports (see [Table 10](#)) causes the corresponding pin to be at high level (3.3V), and writing a 0 causes the corresponding pin to be held at low level (GND). The data direction register [UDIR70](#) define individual pins as input or output pins (see the [User \(USR\) Ports](#) section for details).

Table 10: Port Registers

| Register | SFR Address | R/W | Description |
|----------|-------------|-----|---|
| USR70 | 0x90 | R/W | Register for User port bits 7:0 read and write operations (pins USR0...USR7). |
| UDIR70 | 0x91 | R/W | Data direction register for User port bits 0:7. Setting a bit to 0 means that the corresponding pin is an output. |

All ports on the chip are bi-directional. Each consists of a Latch (SFR USR70), an output driver, and an input buffer, therefore the MPU can output or read data through any of these ports if they are not used for alternate purposes.

1.6 Instruction Set

All instructions of the generic 8051 microcontroller are supported. A complete list of the instruction set and of the associated op-codes is contained in the *73S12xxF Software User's Guide*.

1.7 Peripheral Descriptions

1.7.1 Oscillator and Clock Generation

The 73S1217F has two oscillator circuits; one for the main CPU clock and another for the RTC. The main oscillator circuit is designed to operate with various crystal or external clock frequencies. An internal divider working in conjunction with a PLL and VCO provides a 96MHz internal clock within the 73S1217F. 96 MHz is the required frequency for proper operation of specific peripheral blocks such as the USB, specific timers, ISO 7816 UART and interfaces, Step-up converter, and keypad. The clock generation and control circuits are shown in [Figure 3](#).

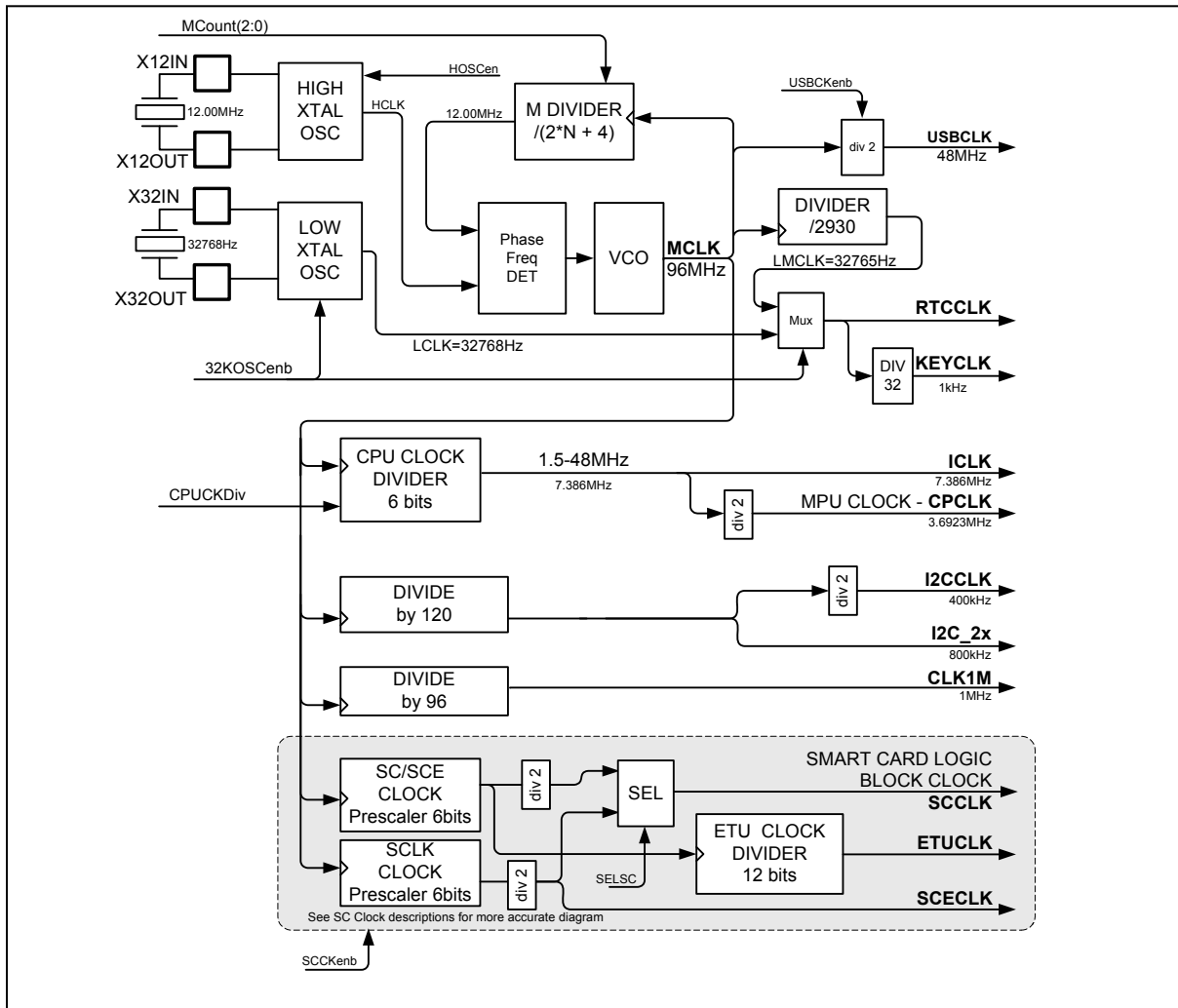

Figure 3: Clock Generation and Control Circuits

The master clock control register enables different sections of the clock circuitry and specifies the value of the VCO Mcount divider. The MCLK must be configured to operate at 96MHz to ensure proper operation of some of the peripheral blocks according to the following formula:

$$\text{MCLK} = (\text{Mcount} * 2 + 4) * F_{\text{XTAL}} = 96\text{MHz}$$

Mcount is configured in the [MCLKCtl](#) register must be bound between a value of 1 to 7. The possible crystal or external clock frequencies for getting MCLK = 96MHz are shown in Table 11.

Table 11: Frequencies and Mcount Values for MCLK = 96MHz

| F _{XTAL} (MHz) | Mcount (N) |
|-------------------------|------------|
| 12.00 | 2 |
| 9.60 | 3 |
| 8.00 | 4 |
| 6.86 | 5 |
| 6.00 | 6 |

Master Clock Control Register (MCLKCtl): 0x8F ← 0x0A

Table 12: The MCLKCtl Register

| MSB | | | | | LSB | | |
|-------|------|------|-------|-------|-------|-------|-------|
| HSOEN | KBEN | SCEN | USBEN | 32KEN | MCT.2 | MCT.1 | MCT.0 |

| Bit | Symbol | Function |
|-----------|--------|--|
| MCLKCtl.7 | HSOEN | High-speed oscillator disable. When set = 1, disables the high-speed crystal oscillator and VCO/PLL system. Do not set this bit = 1. |
| MCLKCtl.6 | KBEN | 1 = Disable the keypad logic clock. |
| MCLKCtl.5 | SCEN | 1 = Disable the smart card logic clock. |
| MCLKCtl.4 | USBEN | 1 = Disable the USB logic clock. |
| MCLKCtl.3 | 32KEN | 1 = Disable the 32Khz oscillator. When the 32kHz oscillator is enabled, the RTC and other circuits such as debounce clocks are clocked using the 32kHz oscillator output. When disabled, the main oscillator provides the 32kHz clock for the RTC and other circuits. Note: This bit must be set if there is no 32KHz crystal. Some internal clocks and circuits will not run if the oscillator is enabled and no crystal is connected. |
| MCLKCtl.2 | MCT.2 | This value determines the ratio of the VCO frequency (MCLK) to the high-speed crystal oscillator frequency such that: MCLK = (MCount*2 + 4)* F _{XTAL} . The default value is MCount = 2h such that MCLK = (2*2 + 4)*12.00MHz = 96MHz. |
| MCLKCtl.1 | MCT.1 | |
| MCLKCtl.0 | MCT.0 | |

The MPU clock that drives the CPU core defaults to 3.6923MHz after reset. The MPU clock is scalable by configuring the MPU Clock Control register ([MPUCKCtl](#)).

MPU Clock Control Register (MPUCKctl): 0xFFA1 ← 0x0C**Table 13: The MPUCKctl Register**

| MSB | | | | | | | | LSB | |
|------------|--------|--|--|--------|--------|--------|--------|--------|--------|
| - | | - | | MDIV.5 | MDIV.4 | MDIV.3 | MDIV.2 | MDIV.1 | MDIV.0 |
| Bit | Symbol | Function | | | | | | | |
| MPUCKctl.7 | - | | | | | | | | |
| MPUCKctl.6 | - | | | | | | | | |
| MPUCKctl.5 | MDIV.5 | This value determines the ratio of the MPU master clock frequency to the VCO frequency (MCLK) such that $MPUClk = MCLK / (2 * (MPUCKDiv(5:0) + 1))$. Do not use values of 0 or 1 for MPUCKDiv(n). Default is 0Ch to set CPCLK = 3.6923MHz. | | | | | | | |
| MPUCKctl.4 | MDIV.4 | | | | | | | | |
| MPUCKctl.3 | MDIV.3 | | | | | | | | |
| MPUCKctl.2 | MDIV.2 | | | | | | | | |
| MPUCKctl.1 | MDIV.1 | | | | | | | | |
| MPUCKctl.0 | MDIV.0 | | | | | | | | |

The oscillator circuits are designed to connect directly to standard parallel resonant crystal in a Pierce oscillator configuration. Each side of the crystal should include a 22pF capacitor to ground for both oscillator circuits and a 1MΩ resistor is required across the 12MHz crystal.

The CPU clock is available as an output on pin CPUCLK.

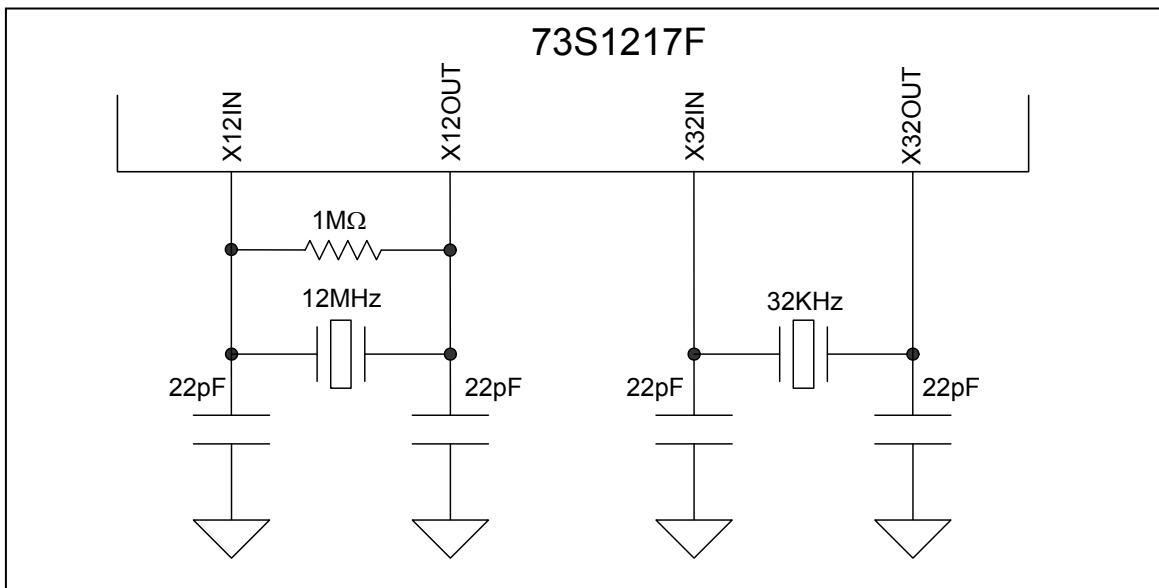

Note: The crystals should be placed as close as possible to the IC, and vias should be avoided.

Figure 4: Oscillator Circuit

1.7.2 Power Supply Management

The detailed power supply management logic block diagram is shown in Figure 5.

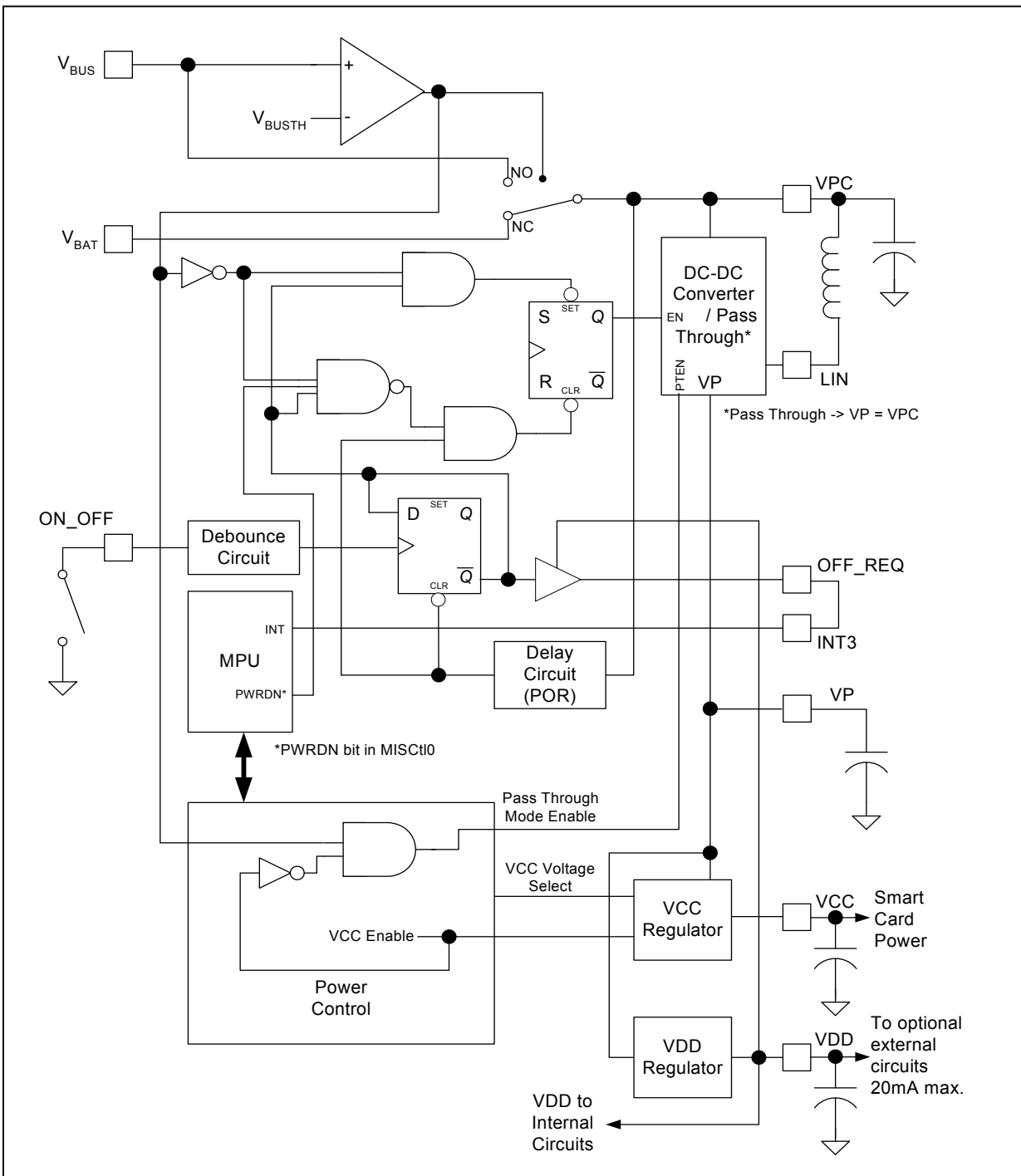

Figure 5: Detailed Power Management Logic Block Diagram

The 73S1217F contains a power supply and converter circuit that takes power from any one of three sources; V_{PC} , V_{BUS} , or V_{BAT} .

V_{PC} is specified to range from 2.7 to 6.5 volts. It can typically be supplied by a single cell battery with a voltage range of 2.7 to approximately 3.1 volts or by a standard supply of 3.3 or 5 volts.

V_{BUS} is typically supplied by an external power supply and ranges in value from 4.4 to 5.5 volts (6.5V maximum).

V_{BAT} is expected to be supplied from a battery of three to four series connected cells with a voltage value of 4.0 to 6.5 volts.

V_{BAT} and V_{BUS} are internally switched to V_{PC} by two separate FET switches configured as a SPDT switch (break-before-make). They will not be enabled at the same time. V_{BUS} is automatically selected in lieu of V_{BAT} when V_{BUS} is present (i.e. V_{BUS} always has the priority).

If V_{PC} is provided and either V_{BAT} or V_{BUS} is also used, the source of V_{PC} must be diode isolated from the V_{PC} pin to prevent current flow from V_{BAT} or V_{BUS} into the V_{PC} source.

The power that is supplied to the V_{PC} pin (externally or internally, i.e. through V_{BAT} or V_{BUS} – see above) is up-converted to the intermediate voltage V_P utilizing an inductive, step-up converter. A series power inductor (nominal value = 10 μ H) must be connected from V_{PC} to the pin LIN, and a 10 μ F low ESR filter capacitor must be connected to V_{PC} .

V_P requires a 4.7 μ F filter capacitor and will have a nominal value of 5.5V during normal operation. V_P is used internally by the smart card electrical interface circuit and is regulated to the desired smart card supply V_{CC} voltage (can be programmed for values of 5V, 3V, or 1.8V).

V_P is also used internally to generate a 3.3V nominal, regulated power supply V_{DD} . V_{DD} is output on pin 68 and must be directly tied to all other V_{DD} pins on the 73S1217F (pins 28 and 40). V_{DD} powers all the digital logic, input/output buffering, and analog functions. It can also be used for external circuitry: Up to 20mA current can be supplied to external devices simultaneously to the 73S1217F's digital core maximum consumption.

1.7.3 Power ON/OFF

The 73S1217F features an ON_OFF input pin for a momentary contact, main-system ON/OFF switch. The purpose of this switch is to place the circuit in a very low-power mode – the “OFF” mode – where the digital core of the circuit is no longer powered, therefore allowing the lowest possible current consumption.

When in “OFF” mode, an action on the ON/OFF switch will turn-on the power supply of the digital core (V_{DD}) and apply a power-on-reset condition. Alternatively, entering the “OFF” mode from the “ON” mode requires firmware action.

When in “ON” mode, an action on the ON/OFF switch will send a request to the controller that will have to be acknowledged (firmware action required) in order to enter the “OFF” state.

When placed into the “OFF” state, the 73S1217F will consume minimum current from V_{PC} and V_{BAT} ; V_P and V_{DD} will be unavailable (V_{DD} out = 0V and V_P = 0V).

When in “ON” mode, the 73S1217F will operate normally, with all the features described in this document available. V_P and V_{DD} will be available (V_{DD} out = 3.3V and V_P = 5.5V nominal).

Whenever V_{BUS} power is supplied, the circuit will be automatically in the “ON” state: The functions of the ON/OFF switch and circuitry are overridden and the 73S1217F is in the “ON” state with V_P and V_{DD} available.

Without V_{BUS} applied, the circuit is by default in the “OFF” state, and will respond only to the ON_OFF pin. The ON_OFF pin should be connected to an SPST switch to ground. If the circuit is OFF and the switch is closed for a de-bounce period of 50-100ms, the circuit will go into the “ON” state wherein all functions are operating in normal fashion. If the circuit is in the “ON” state and the ON_OFF pin is connected to ground for a period greater than the de-bounce period, OFF_REQ will be asserted high and held regardless of the state of ON/OFF. The OFF_REQ signal should be connected to one of the interrupt pins to signal the CPU core that a request to shutdown has been initiated. The firmware will

acknowledge this request by setting the SCPWRDN bit in the Smart Card V_{CC} Control/Status Register (**VccCtl**) high after it has completed all shutdown activities. When SCPWRDN is set high, the circuit will deactivate the smart card interface if required and turn off all analog functions and the V_{DD} supply for the logic and companion circuits. The default state upon application of power is the “OFF” state unless power is supplied to the V_{BUS} supply. Note that at any time, the firmware may assert SCPWRDN and the 73S1217F will go into the “OFF” state (when V_{BUS} is not present). If the OFF switch function is not desired and the application does not need to shut down power on VDD, the ON_OFF input can be permanently grounded which will automatically turn on VDD when power is supplied on any of the VPC, VBAT or VBUS power supply inputs.

If power is applied to both V_{BAT} and V_{BUS} , the circuit will automatically consume power from only the V_{BUS} source. The 73S1217F will be unconditionally “ON” when V_{BUS} is applied. If the V_{BUS} source is removed, the 73S1217F will switchover to the VBAT input supply and remain in the “ON” state. The firmware should assert SCPWRDN based on no activity or V_{BUS} removal to reduce battery power consumption. When operating from V_{BUS} , and not calling for V_{CC} , the step-up converter becomes a simple switch connecting V_{BUS} to V_P in order to save power. This condition is appropriate for the USB “SUSPEND” state. The USB “SUSPEND” state requires the power supply current to be less than 500uA. In order to obtain and meet this low current limitation, the firmware must configure the 73S1217F into a power-down condition using less than 20uA from V_{DD} .

Note: When the ON_OFF switch function is not needed, i.e. when the 73S1217F must be in an always-ON state when using another supply than VBUS (V_{PC} or V_{BAT}), some external discrete components are needed.

1.7.4 Power Control Modes

The 73S1217F contains circuitry to disable portions of the device and place it into a lower power standby mode or power down the 73S1217F into its “OFF” mode. The standby mode will stop the core, clock subsystem and the peripherals connected to it. This is accomplished by either shutting off the power or disabling the clock going to the block. The miscellaneous control registers **MISCTI0**, **MISCTI1** and the Master Clock Control register (**MCLKCtl**) provide control over the power modes. The PWRDN bit in **MISCTI0** will set up the 73S1217F for either standby or “OFF” modes. Depending on the state of the ON/OFF circuitry and power applied to the VBUS input, the 73S1217F will go into either standby mode or power “OFF” mode. If system power is provided by, VBUS or the ON/OFF circuitry is in the “ON” state, the MPU core will be placed into standby mode. If the VBUS input is not sourcing power and the ON/OFF circuitry is in the “OFF” state, setting the PWRDN bit will shut down the converter and V_P will turn off. This in turn will turn off the VDD supply and the 73S1217F will be turned “OFF”. The power down modes should only be initiated by setting the PWRDN bit in the **MISCTI0** register and not by manipulating individual control bits in various registers. Figure 6 shows how the PWRDN bit controls the various functions that comprise power down state

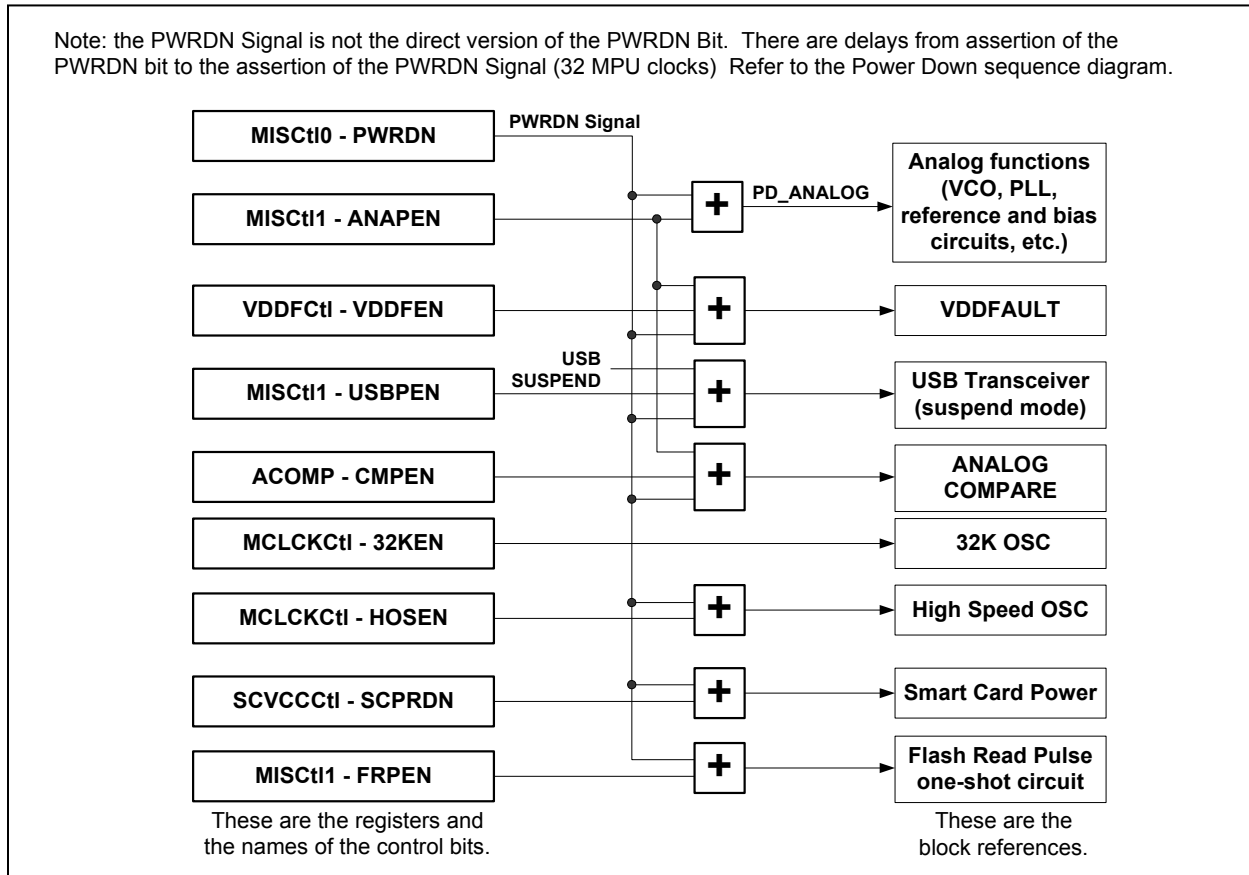

Figure 6: Power-Down Control

When the PWRDN bit is set, the clock subsystem will provide a delay of 32 MPUCLK cycles to allow the program to set the STOP bit in the PCON register. This delay will enable the program to properly halt the core before the analog circuits shut down (high speed oscillator, VCO/PLL, voltage reference and bias circuitry, etc.). The PDMUX bit in SFR INT5Ctl should be set prior to setting the PWRDN bit in order to configure the wake up interrupt logic. The power down mode is de-asserted by any of the interrupts connected to external interrupts 0, 4 and 5 (external USR[0:7], smart card and Keypad). These interrupt sources are OR'ed together and routed through delay logic into INTO to provide this functionality. The interrupt will turn on the power to all sections that were shut off and start the clock subsystem. After the clock subsystem clocks start running, the MPUCLK begins to clock a 512 count delay counter. When the counter times out, the interrupt will then be active on INTO and the program can resume. Figure 7 shows the detailed logic for waking up the 73S1217F from a power down state using these specific interrupt sources. Figure 8 shows the timing associated with the power down mode.

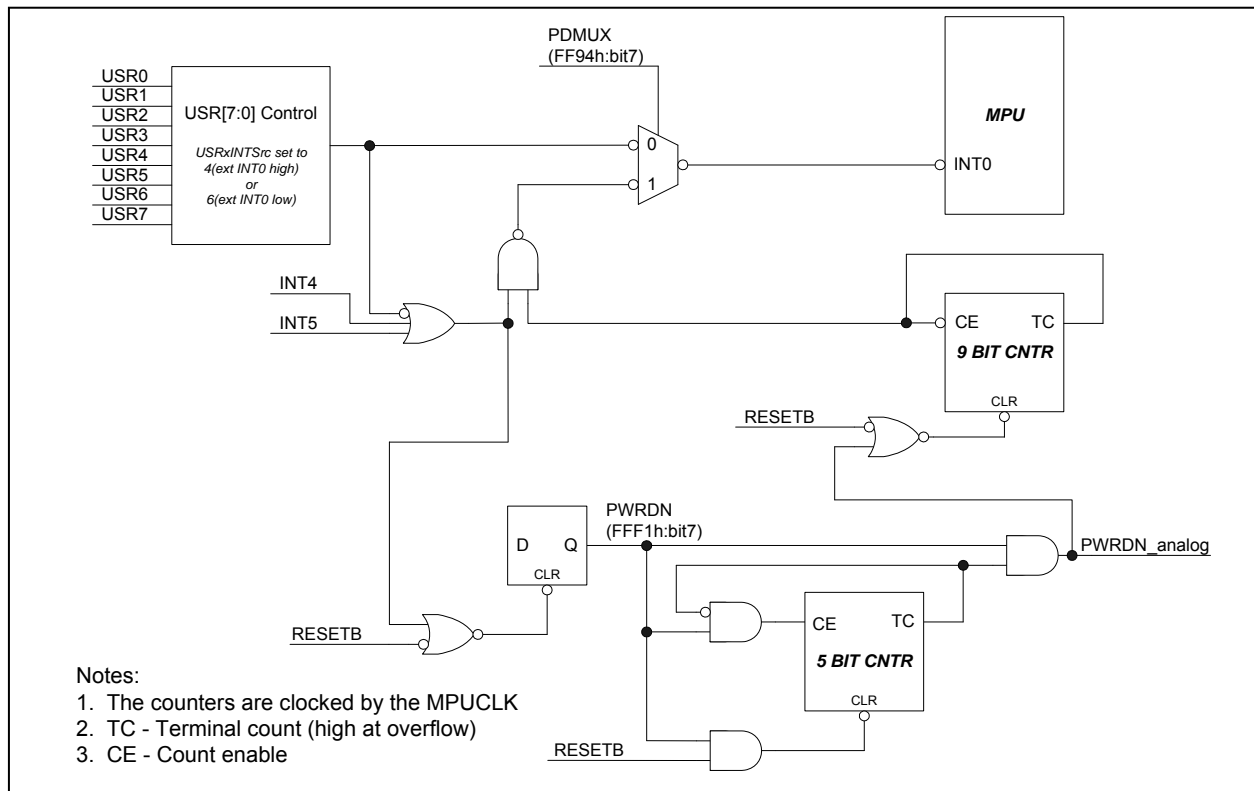

Figure 7: Detail of Power-Down Interrupt Logic

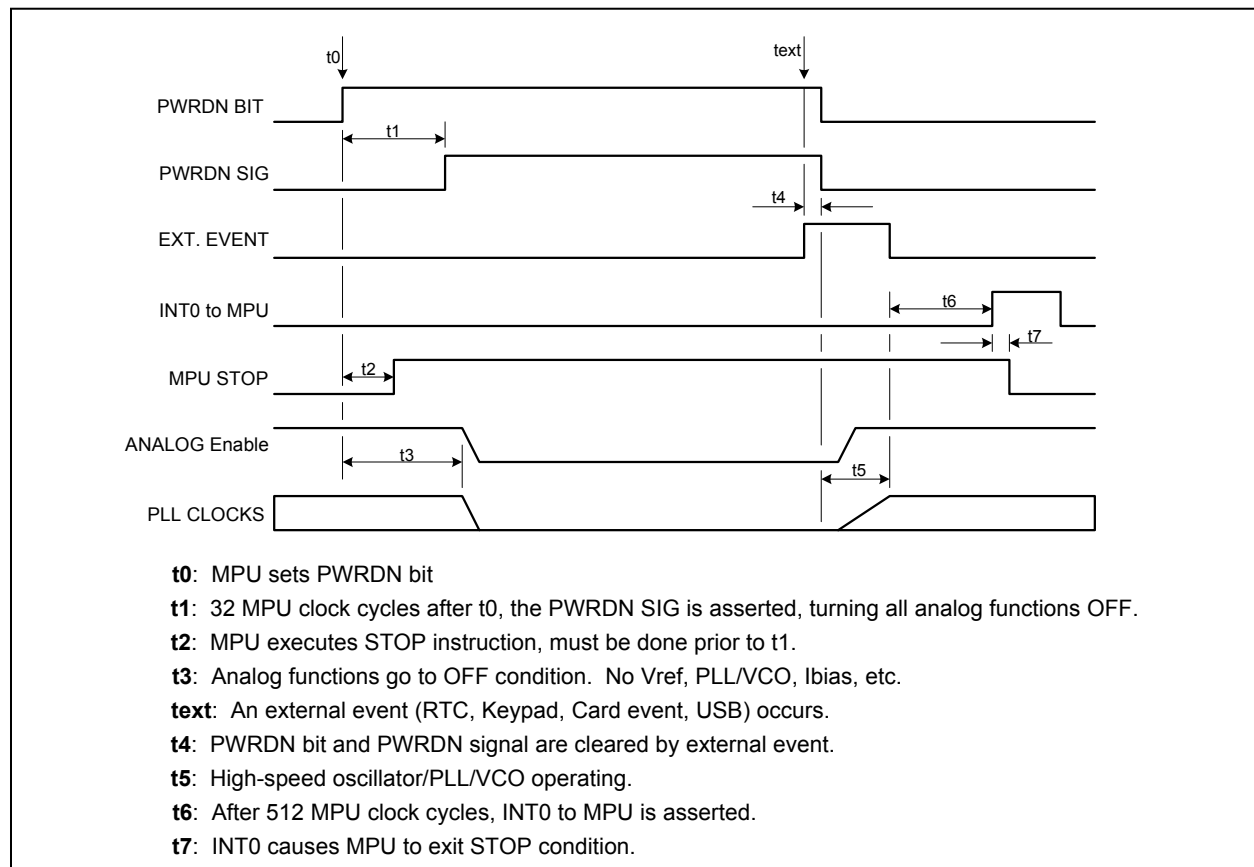

Figure 8: Power-Down Sequencing

External Interrupt Control Register (INT5Ctl): 0xFF94 ← 0x00**Table 14: The INT5Ctl Register**

| MSB | | | | | | | | LSB | |
|-----------|--------|---|--------|--------|--------|-------|-------|-----|--|
| PDMUX | – | RTCIEN | RTCINT | USBIEN | USBINT | KPIEN | KPINT | | |
| Bit | Symbol | Function | | | | | | | |
| INT5Ctl.7 | PDMUX | When set = 1, enables interrupts from USB, RTC, Keypad (normally going to int5), Smart Card interrupts (normally going to int4), or USR(7:0) pins (int0) to cause interrupt on int0. The assertion of the interrupt to int0 is delayed by 512 MPU clocks to allow the analog circuits, including the clock system, to stabilize. This bit must be set prior to asserting the PWRDN bit in order to properly configure the interrupts that will wake up the circuit. This bit is reset = 0 when this register is read. | | | | | | | |
| INT5Ctl.6 | – | | | | | | | | |
| INT5Ctl.5 | RTCIEN | RTC interrupt enable. | | | | | | | |
| INT5Ctl.4 | RTCINT | RTC interrupt flag. | | | | | | | |
| INT5Ctl.3 | USBIEN | USB interrupt enable. | | | | | | | |
| INT5Ctl.2 | USBINT | USB interrupt flag. | | | | | | | |
| INT5Ctl.1 | KPIEN | Keypad interrupt enable. | | | | | | | |
| INT5Ctl.0 | KPINT | Keypad interrupt flag. | | | | | | | |

Miscellaneous Control Register 0 (MISCtl0): 0xFFF1 ← 0x00**Table 15: The MISCtl0 Register**

| MSB | | | | | | | | LSB | |
|-----------|--------|---|---|---|---|---|-------|------|--|
| PWRDN | – | – | – | – | – | – | SLPBK | SSEL | |
| Bit | Symbol | Function | | | | | | | |
| MISCtl0.7 | PWRDN | This bit sets the circuit into a low-power condition. All analog (high speed oscillator and VCO/PLL) functions are disabled 32 MPU clock cycles after this bit is set = 1. This allows time for the next instruction to set the STOP bit in the PCON register to stop the CPU core. The RTC will stay active if it is set to operate from the 32kHz oscillator. The MPU is not operative in this mode. When set, this bit overrides the individual control bits that otherwise control power consumption. | | | | | | | |
| MISCtl0.6 | – | | | | | | | | |
| MISCtl0.5 | – | | | | | | | | |
| MISCtl0.4 | – | | | | | | | | |
| MISCtl0.3 | – | | | | | | | | |
| MISCtl0.2 | – | | | | | | | | |
| MISCtl0.1 | SLPBK | UART loop back testing mode. | | | | | | | |
| MISCtl0.0 | SSEL | Serial port pins select. | | | | | | | |

Miscellaneous Control Register 1 (MISCT11): 0xFFF2 ← 0x10**Table 16: The MISCT11 Register**

| MSB | | | | | | | | LSB |
|-----|---|---|-------|--------|---|--------|--------|--------|
| | – | – | FRPEN | FLSH66 | – | ANAPEN | USBPEN | USBCON |

| Bit | Symbol | Function |
|-----------|---------|---|
| MISCT11.7 | – | |
| MISCT11.6 | – | |
| MISCT11.5 | FRPEN | Flash Read Pulse enable (low). If FRPEN = 1, the Flash Read signal is passed through with no change. When FRPEN = 0 a one-shot circuit that shortens the Flash Read signal is enabled to save power. The Flash Read pulse will shorten to 40 or 66ns (approximate based on the setting of the FLSH66 bit) in duration, regardless of the MPU clock rate. For MPU clock frequencies greater than 10MHz, this bit should be set high. |
| MISCT11.4 | FLSH66 | When high, creates a 66ns Flash read pulse, otherwise creates a 40ns read pulse when FRPEN is set. |
| MISCT11.3 | – | |
| MISCT11.2 | ANAPEN* | 0 = Enable the analog functions that generate VREF and bias current functions. Setting high will turn off the VPD regulator and VCO/PLL functions. |
| MISCT11.1 | USBPEN | 0 = Enable the USB differential transceiver. |
| MISCT11.0 | USBCON | USB pull-up resistor connect enable. |

*Note: The ANAPEN bit should never be set under normal circumstances. Power down control should only be initiated via use of the PWRDN bit in [MISCT10](#).

Master Clock Control Register (MCLKCtl): 0x8F ← 0x0A**Table 17: The MCLKCtl Register**

| MSB | | | | LSB | | | |
|-----------|--------|--|-------|-------|-------|-------|-------|
| HSOEN | KBEN | SCEN | USBEN | 32KEN | MCT.2 | MCT.1 | MCT.0 |
| Bit | Symbol | Function | | | | | |
| MCLKCtl.7 | HSOEN | High-speed oscillator enable. When set = 1, disables the high-speed crystal oscillator and VCO/PLL system. This bit is not changed when the PWRDN bit is set but the oscillator/VCO/PLL is disabled. The HSOEN bit should never be set under normal circumstances. Power down control should only be initiated via use of the PWRDN bit in MISCTIO . | | | | | |
| MCLKCtl.6 | KBEN | 1 = Disable the keypad logic clock. This bit is not changed in PWRDN mode but the function is disabled. | | | | | |
| MCLKCtl.5 | SCEN | 1 = Disable the smart card logic clock. This bit is not changed in PWRDN mode but the function is disabled. Interrupt logic for card insertion/removal remains operable even with smart card clock disabled. | | | | | |
| MCLKCtl.4 | USBEN | 1 = Disable the USB logic clock. This bit is not changed in PWRDN mode but the function is disabled. | | | | | |
| MCLKCtl.3 | 32KEN | 1 = Disable the 32Khz oscillator. This function is not affected by PWRDN mode. Note: This bit must be set if there is no 32KHz crystal. Some internal clocks and circuits will not run if the oscillator is enabled and no crystal is connected. | | | | | |
| MCLKCtl.2 | MCT.2 | This value determines the ratio of the VCO frequency (MCLK) to the high-speed crystal oscillator frequency such that: MCLK = (MCount*2 + 4)*Fxtal. The default value is MCount = 2h such that MCLK = (2*2 + 4)*12.00MHz = 96MHz. | | | | | |
| MCLKCtl.1 | MCT.1 | | | | | | |
| MCLKCtl.0 | MCT.0 | | | | | | |

Power Control Register 0 (PCON): 0x87 ← 0x00

The SMOD bit used for the baud rate generator is setup via this register.

Table 18: The PCON Register

| MSB | | | | | | | | LSB |
|------|---|---|---|-----|-----|------|------|-----|
| SMOD | – | – | – | GF1 | GF0 | STOP | IDLE | |

| Bit | Symbol | Function |
|--------|--------|--|
| PCON.7 | SMOD | If SM0D = 1, the baud rate is doubled. |
| PCON.6 | – | |
| PCON.5 | – | |
| PCON.4 | – | |
| PCON.3 | GF1 | General purpose flag 1. |
| PCON.2 | GF0 | General purpose flag 1. |
| PCON.1 | STOP | Sets CPU to Stop mode. |
| PCON.0 | IDLE | Sets CPU to Idle mode. |

1.7.5 Interrupts

The 80515 core provides 10 interrupt sources with four priority levels. Each source has its own request flag(s) located in a special function register (TCON, IRCON, and SCON). Each interrupt requested by the corresponding flag can be individually enabled or disabled by the enable bits in SFRs IEN0, IEN1, and IEN2. Some of the 10 sources are multiplexed in order to expand the number of interrupt sources. These will be described in more detail in the respective sections.

External interrupts are the interrupts external to the 80515 core, i.e. signals that originate in other parts of the 73S1217F, for example the USB interface, USR I/O, RTC, smart card interface, analog comparators, etc. The external interrupt configuration is shown in Figure 9.

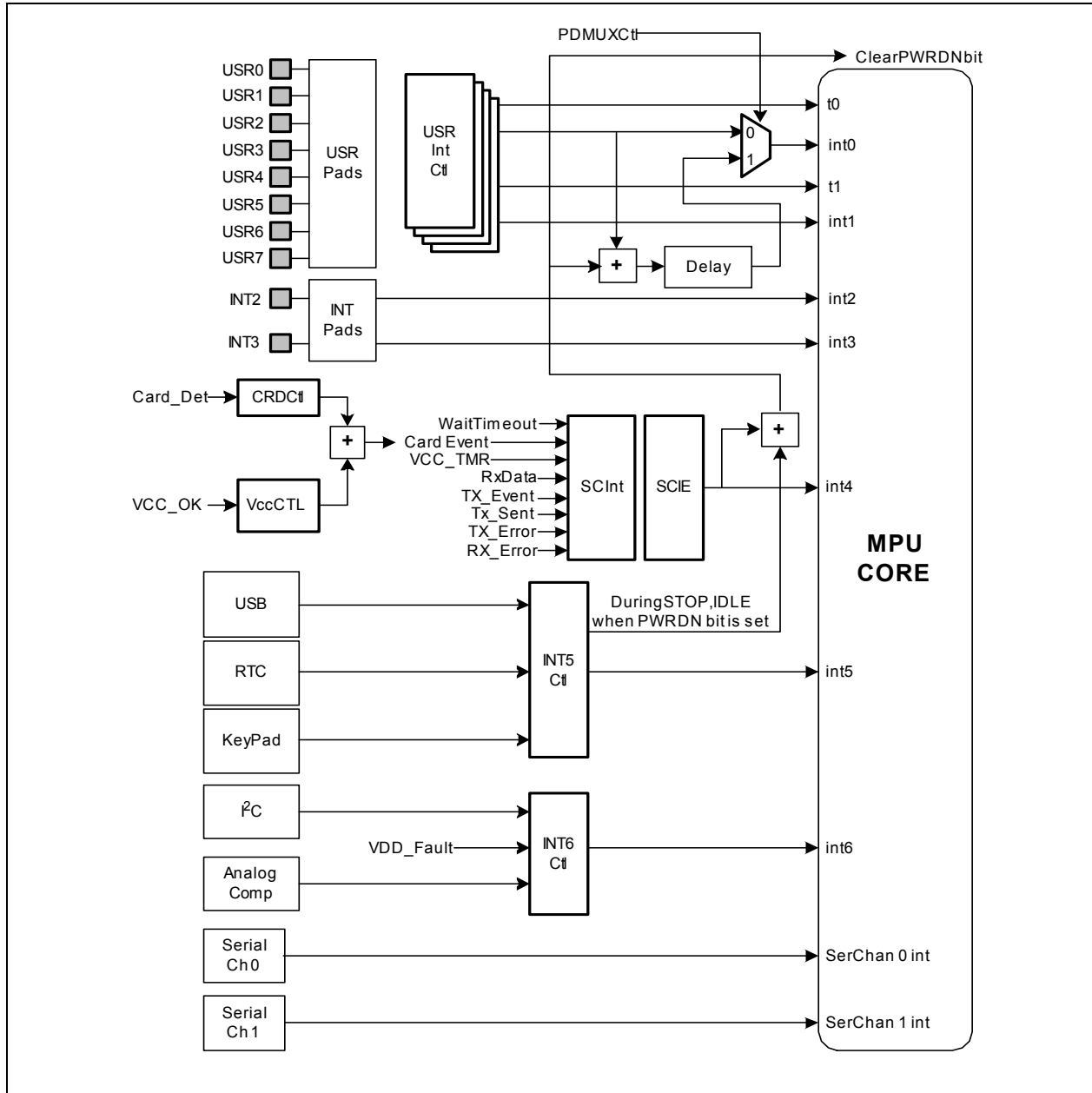

Figure 9: External Interrupt Configuration

1.7.5.1 Interrupt Overview

When an interrupt occurs, the MPU will vector to the predetermined address as shown in Table 32. Once the interrupt service has begun, it can only be interrupted by a higher priority interrupt. The interrupt service is terminated by a return from the RETI instruction. When an RETI is performed, the processor will return to the instruction that would have been next when the interrupt occurred.

When the interrupt condition occurs, the processor will also indicate this by setting a flag bit. This bit is set regardless of whether the interrupt is enabled or disabled. Each interrupt flag is sampled once per machine cycle, then samples are polled by the hardware. If the sample indicates a pending interrupt when the interrupt is enabled, then the interrupt request flag is set. On the next instruction cycle, the interrupt will be acknowledged by hardware forcing an LCALL to the appropriate vector address.

Interrupt response will require a varying amount of time depending on the state of the MPU when the interrupt occurs. If the MPU is performing an interrupt service with equal or greater priority, the new interrupt will not be invoked. In other cases, the response time depends on the current instruction. The fastest possible response to an interrupt is 7 machine cycles. This includes one machine cycle for detecting the interrupt and six cycles to perform the LCALL.

1.7.5.2 Special Function Registers for Interrupts

Interrupt Enable 0 Register (IEN0): 0xA8 ← 0x00

Table 19: The IEN0 Register

| | | | | | | | |
|-----|-----|---|-----|-----|-----|-----|-----|
| MSB | LSB | | | | | | |
| EAL | WDT | – | ES0 | ET1 | EX1 | ET0 | EX0 |

| Bit | Symbol | Function |
|--------|--------|---|
| IEN0.7 | EAL | EAL = 0 – disable all interrupts. |
| IEN0.6 | WDT | Not used for interrupt control. |
| IEN0.5 | – | |
| IEN0.4 | ES0 | ES0 = 0 – disable serial channel 0 interrupt. |
| IEN0.3 | ET1 | ET1 = 0 – disable timer 1 overflow interrupt. |
| IEN0.2 | EX1 | EX1 = 0 – disable external interrupt 1. |
| IEN0.1 | ET0 | ET0 = 0 – disable timer 0 overflow interrupt. |
| IEN0.0 | EX0 | EX0 = 0 – disable external interrupt 0. |

Interrupt Enable 1 Register (IEN1): 0xB8 ← 0x00**Table 20: The IEN1 Register**

| | | | | | | | | | |
|---|------|------|-----|-----|-----|-----|-----|---|--|
| MSB | LSB | | | | | | | | |
| <table border="1" style="width: 100%; border-collapse: collapse;"> <tr> <td style="width: 12.5%; text-align: center;">–</td> <td style="width: 12.5%; text-align: center;">SWDT</td> <td style="width: 12.5%; text-align: center;">EX6</td> <td style="width: 12.5%; text-align: center;">EX5</td> <td style="width: 12.5%; text-align: center;">EX4</td> <td style="width: 12.5%; text-align: center;">EX3</td> <td style="width: 12.5%; text-align: center;">EX2</td> <td style="width: 12.5%; text-align: center;">–</td> </tr> </table> | – | SWDT | EX6 | EX5 | EX4 | EX3 | EX2 | – | |
| – | SWDT | EX6 | EX5 | EX4 | EX3 | EX2 | – | | |

| Bit | Symbol | Function |
|--------|--------|---|
| IEN1.7 | – | |
| IEN1.6 | SWDT | Not used for interrupt control. |
| IEN1.5 | EX6 | EX6 = 0 – disable external interrupt 6. |
| IEN1.4 | EX5 | EX5 = 0 – disable external interrupt 5. |
| IEN1.3 | EX4 | EX4 = 0 – disable external interrupt 4. |
| IEN1.2 | EX3 | EX3 = 0 – disable external interrupt 3. |
| IEN1.1 | EX2 | EX2 = 0 – disable external interrupt 2. |
| IEN1.0 | – | |

Interrupt Enable 2 Register (IEN2): 0x9A ← 0x00**Table 21: The IEN2 Register**

| | | | | | | | | | |
|--|-----|---|---|---|---|---|-----|-----|--|
| MSB | LSB | | | | | | | | |
| <table border="1" style="width: 100%; border-collapse: collapse;"> <tr> <td style="width: 12.5%; text-align: center;">–</td> <td style="width: 12.5%; text-align: center;">–</td> <td style="width: 12.5%; text-align: center;">–</td> <td style="width: 12.5%; text-align: center;">–</td> <td style="width: 12.5%; text-align: center;">–</td> <td style="width: 12.5%; text-align: center;">–</td> <td style="width: 12.5%; text-align: center;">–</td> <td style="width: 12.5%; text-align: center;">ES1</td> </tr> </table> | – | – | – | – | – | – | – | ES1 | |
| – | – | – | – | – | – | – | ES1 | | |

| Bit | Symbol | Function |
|--------|--------|---|
| IEN2.0 | ES1 | ES1 = 0 – disable serial channel interrupt. |

Timer/Counter Control Register (TCON): 0x88 ← 0x00**Table 22: The TCON Register**

| | | | | | | | |
|-----|-----|-----|-----|-----|-----|-----|-----|
| MSB | LSB | | | | | | |
| TF1 | TR1 | TF0 | TR0 | IE1 | IT1 | IE0 | IT0 |

| Bit | Symbol | Function |
|--------|--------|--|
| TCON.7 | TF1 | Timer 1 overflow flag. |
| TCON.6 | TR1 | Not used for interrupt control. |
| TCON.5 | TF0 | Timer 0 overflow flag. |
| TCON.4 | TR0 | Not used for interrupt control. |
| TCON.3 | IE1 | Interrupt 1 edge flag is set by hardware when the falling edge on external interrupt int1 is observed. Cleared when an interrupt is processed. |
| TCON.2 | IT1 | Interrupt 1 type control bit. 1 selects falling edge and 0 selects low level for input pin to cause an interrupt. |
| TCON.1 | IE0 | Interrupt 0 edge flag is set by hardware when the falling edge on external interrupt int0 is observed. Cleared when an interrupt is processed. |
| TCON.0 | IT0 | Interrupt 0 type control bit. 1 selects falling edge and 0 sets low level for input pin to cause interrupt. |

Timer/Interrupt 2 Control Register (T2CON): 0xC8 ← 0x00**Table 23: The T2CON Register**

| | | | | | | | |
|-----|------|------|---|---|---|---|---|
| MSB | LSB | | | | | | |
| – | I3FR | I2FR | – | – | – | – | – |

| Bit | Symbol | Function |
|---------|--------|--|
| T2CON.7 | – | |
| T2CON.6 | I3FR | External interrupt 3 failing/rising edge flag. I3FR = 0 external interrupt 3 negative transition active. I3FR = 1 external interrupt 3 positive transition active. |
| T2CON.5 | I2FR | External interrupt 3 failing/rising edge flag. I2FR = 0 external interrupt 3 negative transition active. I2FR = 1 external interrupt 3 positive transition active. |
| T2CON.4 | – | |
| T2CON.3 | – | |
| T2CON.2 | – | |
| T2CON.1 | – | |
| T2CON.0 | – | |

Interrupt Request Register (IRCON): 0xC0 ← 0x00**Table 24: The IRCON Register**

| MSB | | | | LSB | | | |
|-----|---|-----|------|------|------|------|---|
| – | – | EX6 | IEX5 | IEX4 | IEX3 | IEX2 | – |

| Bit | Symbol | Function |
|---------|--------|----------------------------|
| IRCON.7 | – | |
| IRCON.6 | – | |
| IRCON.5 | IEX6 | External interrupt 6 flag. |
| IRCON.4 | IEX5 | External interrupt 5 flag. |
| IRCON.3 | IEX4 | External interrupt 4 flag. |
| IRCON.2 | IEX3 | External interrupt 3 flag. |
| IRCON.1 | IEX2 | External interrupt 2 flag. |
| IRCON.0 | – | |

1.7.5.3 External Interrupts

The external interrupts (external to the CPU core) are connected as shown in Table 25. Interrupts with multiple sources are OR'ed together and individual interrupt source control is provided in XRAM SFRs to mask the individual interrupt sources and provide the corresponding interrupt flags. Multifunction USR [7:0] pins control Interrupts 0 and 1. Dedicated external interrupt pins INT2 and INT3 control interrupts 2 and 3. The polarity of interrupts 2 and 3 is programmable in the MPU. Interrupts 4, 5 and 6 have multiple peripheral sources and are multiplexed to one of these three interrupts. The peripheral functions will be described in subsequent sections. Generic 80515 MPU literature states that interrupts 4 through 6 are defined as rising edge sensitive. Thus, the hardware signals attached to interrupts 4, 5 and 6 are converted to rising edge level by the hardware.

SFR (special function register) enable bits must be set to permit any of these interrupts to occur. Likewise, each interrupt has its own flag bit that is set by the interrupt hardware and is reset automatically by the MPU interrupt handler.

Table 25: External MPU Interrupts

| External Interrupt | Connection | Polarity | Flag Reset |
|--------------------|---|--------------------------------|------------|
| 0 | USR I/O High Priority | see USRIntCtlx | Automatic |
| 1 | USR I/O Low Priority | see USRIntCtlx | Automatic |
| 2 | External Interrupt Pin INT2 | Edge selectable | Automatic |
| 3 | External Interrupt Pin INT3 | Edge selectable | Automatic |
| 4 | Smart Card Interrupts | N/A | Automatic |
| 5 | USB, RTC and Keypad | N/A | Automatic |
| 6 | I ² C, V _{DD} _Fault, Analog Comp | N/A | Automatic |

Note: Interrupts 4, 5 and 6 have multiple interrupt sources and the flag bits are cleared upon reading of the corresponding register. To prevent any interrupts from being ignored, the register containing multiple interrupt flags should be stored temporary to allow each interrupt flag to be tested separately to see which interrupt(s) is/are pending.

Table 26: Control Bits for External Interrupts

| Enable Bit | Description | Flag Bit | Description |
|------------|-----------------------------|----------|---------------------------|
| EX0 | Enable external interrupt 0 | IE0 | External interrupt 0 flag |
| EX1 | Enable external interrupt 1 | IE1 | External interrupt 1 flag |
| EX2 | Enable external interrupt 2 | IEX2 | External interrupt 2 flag |
| EX3 | Enable external interrupt 3 | IEX3 | External interrupt 3 flag |
| EX4 | Enable external interrupt 4 | IEX4 | External interrupt 4 flag |
| EX5 | Enable external interrupt 5 | IEX5 | External interrupt 5 flag |
| EX6 | Enable external interrupt 6 | IEX6 | External interrupt 6 flag |

1.7.5.4 Power Down Interrupt Logic

The 73S1217F contains special interrupt logic to allow INT0 to wake up the CPU from a power down (CPU STOP) state. See the [Power Control Modes](#) section for details.

1.7.5.5 Interrupt Priority Level Structure

All interrupt sources are combined in groups, as shown in Table 27.

Table 27: Priority Level Groups

| Group | | | |
|-------|----------------------------|----------------------------|----------------------|
| 0 | External interrupt 0 | Serial channel 1 interrupt | |
| 1 | Timer 0 interrupt | – | External interrupt 2 |
| 2 | External interrupt 1 | – | External interrupt 3 |
| 3 | Timer 1 interrupt | – | External interrupt 4 |
| 4 | Serial channel 0 interrupt | – | External interrupt 5 |
| 5 | – | – | External interrupt 6 |

Each group of interrupt sources can be programmed individually to one of four priority levels by setting or clearing one bit in the special function register IP0 and one in IP1. If requests of the same priority level are received simultaneously, an internal polling sequence as per [Table 31](#) determines which request is serviced first.

IEN enable bits must be set to permit any of these interrupts to occur. Likewise, each interrupt has its own flag bit that is set by the interrupt hardware and is reset automatically by the MPU interrupt handler.

Interrupt Priority 0 Register (IP0): 0xA9 ← 0x00**Table 28: The IP0 Register**

| MSB | | | | | | | | LSB |
|-----|------|-------|-------|-------|-------|-------|-------|-----|
| – | WDTS | IP0.5 | IP0.4 | IP0.3 | IP0.2 | IP0.1 | IP0.0 | |

Note: WDTS is not used for interrupt controls.

Interrupt Priority 1 Register (IP1): 0xB9 ← 0x00**Table 29: The IP1 Register**

| | | | | | | | | |
|-----|---|---|-------|-------|-------|-------|-------|-------|
| MSB | | | | | | | | LSB |
| | - | - | IP1.5 | IP1.4 | IP1.3 | IP1.2 | IP1.1 | IP1.0 |

Table 30: Priority Levels

| IP1.x | IP0.x | Priority Level |
|-------|-------|------------------|
| 0 | 0 | Level0 (lowest) |
| 0 | 1 | Level1 |
| 1 | 0 | Level2 |
| 1 | 1 | Level3 (highest) |

Table 31: Interrupt Polling Sequence

| | |
|----------------------------|-----------------------|
| External interrupt 0 | Polling sequence ↓ |
| Serial channel 1 interrupt | |
| Timer 0 interrupt | |
| External interrupt 2 | |
| External interrupt 1 | |
| External interrupt 3 | |
| Timer 1 interrupt | |
| Serial channel 0 interrupt | |
| External interrupt 4 | |
| External interrupt 5 | |
| External interrupt 6 | |

1.7.5.6 Interrupt Sources and Vectors

Table 32 shows the interrupts with their associated flags and vector addresses.

Table 32: Interrupt Vectors

| Interrupt Request Flag | Description | Interrupt Vector Address |
|------------------------|----------------------------|--------------------------|
| N/A | Chip Reset | 0x0000 |
| IE0 | External interrupt 0 | 0x0003 |
| TF0 | Timer 0 interrupt | 0x000B |
| IE1 | External interrupt 1 | 0x0013 |
| TF1 | Timer 1 interrupt | 0x001B |
| RI0/TI0 | Serial channel 0 interrupt | 0x0023 |
| RI1/TI1 | Serial channel 1 interrupt | 0x0083 |
| IEX2 | External interrupt 2 | 0x004B |
| IEX3 | External interrupt 3 | 0x0053 |
| IEX4 | External interrupt 4 | 0x005B |
| IEX5 | External interrupt 5 | 0x0063 |
| IEX6 | External interrupt 6 | 0x006B |

1.7.6 UART

The 80515 core of the 73S1217F includes two separate UARTs that can be programmed to communicate with a host. The 73S1217F can only connect one UART at a time since there is only one set of TX and Rx pins. The [MISCT10](#) register is used to select which UART is connected to the TX and RX pins. Each UART has a different set of operating modes that the user can select according to their needs. The UART is a dedicated 2-wire serial interface, which can communicate with an external host processor at up to 115,200 bits/s. The TX and RX pins operate at the V_{DD} supply voltage levels and should never exceed 3.6V. The operation of each pin is as follows:

RX: Serial input data is applied at this pin. Conforming to RS-232 standard, the bytes are input LSB first. The voltage applied at RX must not exceed 3.6V.

TX: This pin is used to output the serial data. The bytes are output LSB first.

The 73S1217F has several UART-related read/write registers. All UART transfers are programmable for parity enable, parity select, 2 stop bits/1 stop bit and XON/XOFF options for variable communication baud rates from 300 to 115200 bps. Table 47 shows the selectable UART operation modes and Table 48 shows how the baud rates are calculated.

Table 33: UART Modes

| | UART 0 | UART 1 |
|---------------|--|---|
| Mode 0 | N/A | Start bit, 8 data bits, parity, stop bit, variable baud rate (internal baud rate generator) |
| Mode 1 | Start bit, 8 data bits, stop bit, variable baud rate (internal baud rate generator or timer 1) | Start bit, 8 data bits, stop bit, variable baud rate (internal baud rate generator) |
| Mode 2 | Start bit, 8 data bits, parity, stop bit, fixed baud rate 1/32 or 1/64 of f_{CKMPU} | N/A |
| Mode 3 | Start bit, 8 data bits, parity, stop bit, variable baud rate (internal baud rate generator or timer 1) | N/A |

Note: Parity of serial data is available through the P flag of the accumulator. Seven-bit serial modes with parity, such as those used by the FLAG protocol, can be simulated by setting and reading bit 7 of 8-bit output data. Seven-bit serial modes without parity can be simulated by setting bit 7 to a constant 1. 8-bit serial modes with parity can be simulated by setting and reading the 9th bit, using the control bits S0CON3 and S1CON3 in the [S0CON](#) and [S1CON](#) SFRs.

Table 34: Baud Rate Generation

| | Using Timer 1 | Using Internal Baud Rate Generator |
|---------------------------|--|--|
| Serial Interface 0 | $2^{smod} * f_{CKMPU} / (384 * (256 - TH1))$ | $2^{smod} * f_{CKMPU} / (64 * (2^{10} - S0REL))$ |
| Serial Interface 1 | N/A | $f_{CKMPU} / (32 * (2^{10} - S1REL))$ |

Note: S0REL (9:0) and S1REL (9:0) are 10-bit values derived by combining bits from the respective timer reload registers SxRELH (bits 1:0) and SxRELL (bits 7:0). TH1 is the high byte of timer 1. The SMOD bit is located in the [PCON](#) SFR.

Power Control Register 0 (PCON): 0x87 ← 0x00

The SMOD bit used for the baud rate generator is set up via this register.

Table 35: The PCON Register

| MSB | | | | LSB | | | |
|------|---|---|---|-----|-----|------|------|
| SMOD | – | – | – | GF1 | GF0 | STOP | IDLE |

| Bit | Symbol | Function |
|--------|--------|--|
| PCON.7 | SMOD | If SMOD = 1, the baud rate is doubled. |
| PCON.6 | – | |
| PCON.5 | – | |
| PCON.4 | – | |
| PCON.3 | GF1 | General purpose flag 1. |
| PCON.2 | GF0 | General purpose flag 1. |
| PCON.1 | STOP | Sets CPU to Stop mode. |
| PCON.0 | IDLE | Sets CPU to Idle mode. |

Baud Rate Control Register 0 (BRCON): 0xD8 ← 0x00

The BSEL bit used to enable the baud rate generator is set up via this register.

Table 36: The BRCON Register

| MSB | | | | LSB | | | |
|------|---|---|---|-----|---|---|---|
| BSEL | – | – | – | – | – | – | – |

| Bit | Symbol | Function |
|---------|--------|---|
| BRCON.7 | BSEL | If BSEL = 0, the baud rate is derived using timer 1. If BSEL = 1 the baud rate generator circuit is used. |
| BRCON.6 | – | |
| BRCON.5 | – | |
| BRCON.4 | – | |
| BRCON.3 | – | |
| BRCON.2 | – | |
| BRCON.1 | – | |
| BRCON.0 | – | |

Miscellaneous Control Register 0 (MISCTI0): 0xFFF1 ← 0x00

Transmit and receive (TX and RX) pin selection and loop back test configuration are set up via this register.

Table 37: The MISCTI0 Register

| MSB | | | | | | | | LSB | |
|-------|---|---|---|---|---|---|-------|------|--|
| PWRDN | – | – | – | – | – | – | SLPBK | SSEL | |

| Bit | Symbol | Function | | | | | | | | | | | | | | | |
|-----------|--------|--|-------|------|------|---|---|-----------------------|---|---|-----------------------|---|---|-------------------------------|---|---|-------------------------------|
| MISCTI0.7 | PWRDN | This bit places the 73S1217F into a power down state. | | | | | | | | | | | | | | | |
| MISCTI0.6 | – | | | | | | | | | | | | | | | | |
| MISCTI0.5 | – | | | | | | | | | | | | | | | | |
| MISCTI0.4 | – | | | | | | | | | | | | | | | | |
| MISCTI0.3 | – | | | | | | | | | | | | | | | | |
| MISCTI0.2 | – | | | | | | | | | | | | | | | | |
| MISCTI0.1 | SLPBK | 1 = UART loop back testing mode. The pins TXD and RXD are to be connected together externally (with SLPBK =1) and therefore: <table border="1" style="margin-left: 40px;"> <thead> <tr> <th>SLPBK</th> <th>SSEL</th> <th>Mode</th> </tr> </thead> <tbody> <tr> <td>0</td> <td>0</td> <td>normal using Serial_0</td> </tr> <tr> <td>0</td> <td>1</td> <td>normal using Serial_1</td> </tr> <tr> <td>1</td> <td>0</td> <td>Serial_0 TX feeds Serial_1 RX</td> </tr> <tr> <td>1</td> <td>1</td> <td>Serial_1 TX feeds Serial_0 RX</td> </tr> </tbody> </table> | SLPBK | SSEL | Mode | 0 | 0 | normal using Serial_0 | 0 | 1 | normal using Serial_1 | 1 | 0 | Serial_0 TX feeds Serial_1 RX | 1 | 1 | Serial_1 TX feeds Serial_0 RX |
| SLPBK | SSEL | Mode | | | | | | | | | | | | | | | |
| 0 | 0 | normal using Serial_0 | | | | | | | | | | | | | | | |
| 0 | 1 | normal using Serial_1 | | | | | | | | | | | | | | | |
| 1 | 0 | Serial_0 TX feeds Serial_1 RX | | | | | | | | | | | | | | | |
| 1 | 1 | Serial_1 TX feeds Serial_0 RX | | | | | | | | | | | | | | | |
| MISCTI0.0 | SSEL | Selects either Serial_1 if set =1 or Serial_0 if set = 0 to be connected to RXD and TXD pins. | | | | | | | | | | | | | | | |

1.7.6.1 Serial Interface 0

The Serial Interface 0 can operate in four modes:

- **Mode 0**

Pin RX serves as input and output. TX outputs the shift clock. Eight bits are transmitted with the LSB first. The baud rate is fixed at 1/12 of the crystal frequency. Reception is initialized in Mode 0 by setting the flags in **SOCON** as follows: RI0 = 0 and REN0 = 1. In other modes, a start bit when REN0 = 1 starts receiving serial data.

- **Mode 1**

Pin RX serves as input, and TX serves as serial output. No external shift clock is used, 10 bits are transmitted: a start bit (always 0), 8 data bits (LSB first), and a stop bit (always 1). On receive, a start bit synchronizes the transmission, 8 data bits are available by reading **SOBUF**, and stop bit sets the flag RB80 in the Special Function Register **SOCON**. In mode 1 either internal baud rate generator or timer 1 can be use to specify baud rate.

- **Mode 2**

This mode is similar to Mode 1, with two differences. The baud rate is fixed at 1/32 or 1/64 of oscillator frequency and 11 bits are transmitted or received: a start bit (0), 8 data bits (LSB first), a programmable 9th bit, and a stop bit (1). The 9th bit can be used to control the parity of the serial interface: at transmission, bit TB80 in **SOCON** is output as the 9th bit, and at receive, the 9th bit affects RB80 in Special Function Register **SOCON**.

- **Mode 3**

The only difference between Mode 2 and Mode 3 is that in Mode 3 either internal baud rate generator or timer 1 can be use to specify baud rate.

The **SOBUF** register is used to read/write data to/from the serial 0 interface.

Serial Interface 0 Control Register (SOCON): 0x9B ← 0x00

Transmit and receive data are transferred via this register.

Table 38: The S0CON Register

| MSB | | | | LSB | | | |
|---------|--------|--|--------------------|------------|------------|-----|-----|
| SM0 | SM1 | SM20 | REN0 | TB80 | RB80 | TI0 | RI0 |
| Bit | Symbol | Function | | | | | |
| S0CON.7 | SM0 | These two bits set the UART0 mode: | | | | | |
| | | Mode | Description | SM0 | SM1 | | |
| | | 0 | N/A | 0 | 0 | | |
| S0CON.6 | SM1 | 1 | 8-bit UART | 0 | 1 | | |
| | | 2 | 9-bit UART | 1 | 0 | | |
| | | 3 | 9-bit UART | 1 | 1 | | |
| S0CON.5 | SM20 | Enables the inter-processor communication feature. | | | | | |
| S0CON.4 | REN0 | If set, enables serial reception. Cleared by software to disable reception. | | | | | |
| S0CON.3 | TB80 | The 9th transmitted data bit in Modes 2 and 3. Set or cleared by the MPU, depending on the function it performs (parity check, multiprocessor communication etc.). | | | | | |
| S0CON.2 | RB80 | In Modes 2 and 3 it is the 9th data bit received. In Mode 1, if SM20 is 0, RB80 is the stop bit. In Mode 0 this bit is not used. Must be cleared by software. | | | | | |
| S0CON.1 | TI0 | Transmit interrupt flag, set by hardware after completion of a serial transfer. Must be cleared by software. | | | | | |
| S0CON.0 | RI0 | Receive interrupt flag, set by hardware after completion of a serial reception. Must be cleared by software. | | | | | |

1.7.6.2 Serial Interface 1

The Serial Interface 1 can operate in 2 modes:

- **Mode A**

This mode is similar to Mode 2 and 3 of Serial interface 0, 11 bits are transmitted or received: a start bit (0), 8 data bits (LSB first), a programmable 9th bit, and a stop bit (1). The 9th bit can be used to control the parity of the serial interface: at transmission, bit TB81 in **S1CON** is outputted as the 9th bit, and at receive, the 9th bit affects RB81 in Special Function Register **S1CON**. The only difference between Mode 3 and A is that in Mode A only the internal baud rate generator can be use to specify baud rate.

- **Mode B**

This mode is similar to Mode 1 of Serial interface 0. Pin RX serves as input, and TX serves as serial output. No external shift clock is used, 10 bits are transmitted: a start bit (always 0), 8 data bits (LSB first), and a stop bit (always 1). On receive, a start bit synchronizes the transmission, 8 data bits are available by reading **S1BUF**, and stop bit sets the flag RB81 in the Special Function Register **S1CON**. In mode 1, the internal baud rate generator is use to specify the baud rate.

The **S1BUF** register is used to read/write data to/from the serial 1 interface.

Serial Interface Control Register (S1CON): 0x9B ← 0x00

The function of the serial port depends on the setting of the Serial Port Control Register S1CON.

Table 39: The S1CON Register

| MSB | | | | | | | | LSB | |
|---------|--------|---|-------------|--------------------|------------------|-----|-----|-----|--|
| SM | – | SM21 | REN1 | TB81 | RB81 | TI1 | RI1 | | |
| Bit | Symbol | Function | | | | | | | |
| S1CON.7 | SM | Sets the UART operation mode. | | | | | | | |
| | | SM | Mode | Description | Baud Rate | | | | |
| | | 0 | A | 9-bit UART | variable | | | | |
| | | 1 | B | 8-bit UART | variable | | | | |
| S1CON.6 | – | | | | | | | | |
| S1CON.5 | SM21 | Enables the inter-processor communication feature. | | | | | | | |
| S1CON.4 | REN1 | If set, enables serial reception. Cleared by software to disable reception. | | | | | | | |
| S1CON.3 | TB81 | The 9th transmitted data bit in Mode A. Set or cleared by the MPU, depending on the function it performs (parity check, multiprocessor communication etc.). | | | | | | | |
| S1CON.2 | RB81 | In Mode B, if sm21 is 0, rb81 is the stop bit. Must be cleared by software. | | | | | | | |
| S1CON.1 | TI1 | Transmit interrupt flag, set by hardware after completion of a serial transfer. Must be cleared by software. | | | | | | | |
| S1CON.0 | RI1 | Receive interrupt flag, set by hardware after completion of a serial reception. Must be cleared by software. | | | | | | | |

Multiprocessor operation mode: The feature of receiving 9 bits in Modes 2 and 3 of Serial Interface 0 or in Mode A of Serial Interface 1 can be used for multiprocessor communication. In this case, the slave processors have bit SM20 in **S0CON** or SM21 in **S1CON** set to 1. When the master processor outputs slave's address, it sets the 9th bit to 1, causing a serial port receive interrupt in all the slaves. The slave processors compare the received byte with their network address. If there is a match, the addressed slave will clear SM20 or SM21 and receive the rest of the message, while other slaves will leave the SM20 or SM21 bit unaffected and ignore this message. After addressing the slave, the host will output the rest of the message with the 9th bit set to 0, so no serial port receive interrupt will be generated in unselected slaves.

1.7.7 Timers and Counters

The 80515 has two 16-bit timer/counter registers: Timer 0 and Timer 1. These registers can be configured for counter or timer operations.

In timer mode, the register is incremented every machine cycle, meaning that it counts up after every 12 periods of the MPU clock signal.

In counter mode, the register is incremented when the falling edge is observed at the corresponding input signal T0 or T1 (T0 and T1 are the timer gating inputs derived from USR[0:7] pins, see the [User \(USR\) Ports](#) section). Since it takes 2 machine cycles to recognize a 1-to-0 event, the maximum input count rate is 1/2 of the oscillator frequency. There are no restrictions on the duty cycle, however to ensure proper recognition of 0 or 1 state, an input should be stable for at least 1 machine cycle.

Four operating modes can be selected for Timer 0 and Timer 1. Two Special Function Registers ([TMOD](#) and [TCON](#)) are used to select the appropriate mode.

The Timer 0 load registers are designated as TL0 and TH0 and the Timer 1 load registers are designated as TL1 and TH1.

Timer/Counter Mode Control Register (TMOD): 0x89 ← 0x00

Table 40: The TMOD Register

| | | | | | | | |
|----------------|-----|----|----|----------------|-----|----|----|
| MSB | | | | LSB | | | |
| GATE | C/T | M1 | M0 | GATE | C/T | M1 | M0 |
| Timer 1 | | | | Timer 0 | | | |

Bits TR1 and TR0 in the [TCON](#) register start their associated timers when set.

| Bit | Symbol | Function |
|------------------|--------|--|
| TMOD.7 TMOD.3 | GATE | If set, enables external gate control (USR pin(s) connected to T0 or T1 for Counter 0 or 1, respectively). When T0 or T1 is high, and TRx bit is set (see the TCON register), a counter is incremented every falling edge on T0 or T1 input pin. If not set, the TRx bit controls the corresponding timer. |
| TMOD.6 TMOD.2 | C/T | Selects Timer or Counter operation. When set to 1, the counter operation is performed based on the falling edge of T0 or T1. When cleared to 0, the corresponding register will function as a timer. |
| TMOD.5 TMOD.1 | M1 | Selects the mode for Timer/Counter 0 or Timer/Counter 1, as shown in TMOD description. |
| TMOD.4 TMOD.0 | M0 | Selects the mode for Timer/Counter 0 or Timer/Counter 1, as shown in TMOD description. |

Table 41: Timers/Counters Mode Description

| M1 | M0 | Mode | Function |
|-----------|-----------|-------------|--|
| 0 | 0 | Mode 0 | 13-bit Counter/Timer. |
| 0 | 1 | Mode 1 | 16-bit Counter/Timer. |
| 1 | 0 | Mode 2 | 8-bit auto-reload Counter/Timer. |
| 1 | 1 | Mode 3 | If Timer 1 M1 and M0 bits are set to 1, Timer 1 stops. If Timer 0 M1 and M0 bits are set to 1, Timer 0 acts as two independent 8-bit Timer/Counters. |

Mode 0

Putting either timer/counter into mode 0 configures it as an 8-bit timer/counter with a divide-by-32 prescaler. In this mode, the timer register is configured as a 13-bit register. As the count rolls over from all 1's to all 0's, it sets the timer overflow flag TF0. The overflow flag TF0 then can be used to request an interrupt. The counted input is enabled to the timer when TRx = 1 and either GATE = 0 or TX = 1 (setting GATE = 1 allows the timer to be controlled by external input TX, to facilitate pulse width measurements). TRx are control bits in the special function register TCON; GATE is in TMOD. The 13-bit register consists of all 8 bits of TH1 and the lower 5 bits of TL0. The upper 3 bits of TL0 are indeterminate and should be ignored. Setting the run flag (TRx) does not clear the registers. Mode 0 operation is the same for timer 0 as for timer 1.

Mode 1

Mode 1 is the same as mode 0, except that the timer register is run with all 16 bits.

Mode 2

Mode 2 configures the timer register as an 8-bit counter (TLx) with automatic reload. The overflow from TLx not only sets TFx, but also reloads TLx with the contents of THx, which is preset by software. The reload leaves THx unchanged.

Mode 3

Mode 3 has different effects on timer 0 and timer 1. Timer 1 in mode 3 simply holds its count. The effect is the same as setting TR1 = 0. Timer 0 in mode 3 establishes TL0 and TH0 as two separate counters. TL0 uses the timer 0 control bits: C/T, GATE, TR0, INT0, and TF0. TH0 is locked into a timer function (counting machine cycles) and takes over the use of TR1 and TF1 from timer 1. Thus, TH0 now controls the "timer 1" interrupt. Mode 3 is provided for applications requiring an extra 8-bit timer or counter. When timer 0 is in mode 3, timer 1 can be turned on and off by switching it out of and into its own mode 3, or can still be used by the serial channel as a baud rate generator, or in fact, in any application not requiring an interrupt from timer 1 itself.

Timer/Counter Control Register (TCON): 0x88 ← 0x00**Table 42: The TCON Register**

| MSB | | | | | | | | LSB |
|--------|--------|--|-----|-----|-----|-----|-----|-----|
| | TF1 | TR1 | TF0 | TR0 | IE1 | IT1 | IE0 | IT0 |
| Bit | Symbol | Function | | | | | | |
| TCON.7 | TF1 | The Timer 1 overflow flag is set by hardware when Timer 1 overflows. This flag can be cleared by software and is automatically cleared when an interrupt is processed. | | | | | | |
| TCON.6 | TR1 | Timer 1 Run control bit. If cleared, Timer 1 stops. | | | | | | |
| TCON.5 | TF0 | Timer 0 overflow flag set by hardware when Timer 0 overflows. This flag can be cleared by software and is automatically cleared when an interrupt is processed. | | | | | | |
| TCON.4 | TR0 | Timer 0 Run control bit. If cleared, Timer 0 stops. | | | | | | |
| TCON.3 | IE1 | External Interrupt 1 edge flag. | | | | | | |
| TCON.2 | IT1 | External interrupt 1 type control bit. | | | | | | |
| TCON.1 | IE0 | External Interrupt 0 edge flag. | | | | | | |
| TCON.0 | IT0 | External Interrupt 0 type control bit. | | | | | | |

1.7.8 WD Timer (Software Watchdog Timer)

The software watchdog timer is a 16-bit counter that is incremented once every 24 or 384 clock cycles. After a reset, the watchdog timer is disabled and all registers are set to zero. The watchdog consists of a 16-bit counter (WDT), a reload register ([WDTREL](#)), prescalers (by 2 and by 16), and control logic. Once the watchdog starts, it cannot be stopped unless the internal reset signal becomes active.

Note: It is recommended to use the hardware watchdog timer instead of the software watchdog timer (refer to the [RTC description](#)).

WD Timer Start Procedure: The WDT is started by setting the SWDT flag. When the WDT register enters the state 0x7CFF, an asynchronous WDTS signal will become active. The signal WDTS sets bit 6 in the [IP0](#) register and requests a reset state. WDTS is cleared either by the reset signal or by changing the state of the WDT timer.

Refreshing the WD Timer: The watchdog timer must be refreshed regularly to prevent the reset request signal from becoming active. This requirement imposes an obligation on the programmer to issue two instructions. The first instruction sets WDT and the second instruction sets SWDT. The maximum delay allowed between setting WDT and SWDT is 12 clock cycles. If this period has expired and SWDT has not been set, WDT is automatically reset, otherwise the watchdog timer is reloaded with the content of the [WDTREL](#) register and WDT is automatically reset.

Interrupt Enable 0 Register (IEN0): 0xA8 ← 0x00**Table 43: The IEN0 Register**

| | | | | | | | |
|-----|-----|-----|-----|-----|-----|-----|-----|
| MSB | LSB | | | | | | |
| EAL | WDT | ET2 | ES0 | ET1 | EX1 | ET0 | EX0 |

| Bit | Symbol | Function |
|--------|--------|---|
| IEN0.7 | EAL | EAL = 0 – disable all interrupts. |
| IEN0.6 | WDT | Watchdog timer refresh flag. Set to initiate a refresh of the watchdog timer. Must be set directly before SWDT is set to prevent an unintentional refresh of the watchdog timer. WDT is reset by hardware 12 clock cycles after it has been set. |
| IEN0.5 | – | |
| IEN0.4 | ES0 | ES0 = 0 – disable serial channel 0 interrupt. |
| IEN0.3 | ET1 | ET1 = 0 – disable timer 1 overflow interrupt. |
| IEN0.2 | EX1 | EX1 = 0 – disable external interrupt 1. |
| IEN0.1 | ET0 | ET0 = 0 – disable timer 0 overflow interrupt. |
| IEN0.0 | EX0 | EX0 = 0 – disable external interrupt 0. |

Interrupt Enable 1 Register (IEN1): 0xB8 ← 0x00**Table 44: The IEN1 Register**

| | | | | | | | |
|-----|------|-----|-----|-----|-----|-----|---|
| MSB | LSB | | | | | | |
| – | SWDT | EX6 | EX5 | EX4 | EX3 | EX2 | – |

| Bit | Symbol | Function |
|--------|--------|---|
| IEN1.7 | – | |
| IEN1.6 | SWDT | Watchdog timer start/refresh flag. Set to activate/refresh the watchdog timer. When directly set after setting WDT, a watchdog timer refresh is performed. Bit SWDT is reset by the hardware 12 clock cycles after it has been set. |
| IEN1.5 | EX6 | EX6 = 0 – disable external interrupt 6. |
| IEN1.4 | EX5 | EX5 = 0 – disable external interrupt 5. |
| IEN1.3 | EX4 | EX4 = 0 – disable external interrupt 4. |
| IEN1.2 | EX3 | EX3 = 0 – disable external interrupt 3. |
| IEN1.1 | EX2 | EX2 = 0 – disable external interrupt 2. |
| IEN1.0 | – | |

Interrupt Priority 0 Register (IP0): 0xA9 ← 0x00**Table 45: The IP0 Register**

| | | | | | | | |
|-----|------|-------|-------|-------|-------|-------|-------|
| MSB | LSB | | | | | | |
| - | WDTS | IP0.5 | IP0.4 | IP0.3 | IP0.2 | IP0.1 | IP0.0 |

| Bit | Symbol | Function |
|-------|--------|---|
| IP0.6 | WDTS | Watchdog timer status flag. Set when the watchdog timer has expired. The internal reset will be generated, but this bit will not be cleared by the reset. This allows the user program to determine if the watchdog timer caused the reset to occur and respond accordingly. Can be read and cleared by software. |

Note: The remaining bits in the IP0 register are not used for watchdog control.

Watchdog Timer Reload Register (WDTREL): 0x86 ← 0x00**Table 46: The WDTREL Register**

| | | | | | | | |
|--------|--------|--------|--------|--------|--------|--------|--------|
| MSB | LSB | | | | | | |
| WDPSEL | WDREL6 | WDREL5 | WDREL4 | WDREL3 | WDREL2 | WDREL1 | WDREL0 |

| Bit | Symbol | Function |
|----------------------------|----------|--|
| WDTREL.7 | WDPSEL | Prescaler select bit. When set, the watchdog is clocked through an additional divide-by-16 prescaler. |
| WDTREL.6 to WDTREL.0 | WDREL6-0 | Seven bit reload value for the high-byte of the watchdog timer. This value is loaded to the WDT when a refresh is triggered by a consecutive setting of bits WDT and SWDT. |

1.7.9 User (USR) Ports

The 73S1217F includes 8 pins of general purpose digital I/O (GPIO). On reset or power-up, all USR pins are inputs until they are configured for the desired direction. The pins are configured and controlled by the **USR70** and **UDIR70** SFRs. Each pin declared as USR can be configured independently as an input or output with the bits of the **UDIR70** register. Table 47 lists the direction registers and configurability associated with each group of USR pins. USR pins 0 to 7 are multiple use pins that can be used for general purpose I/O, external interrupts and timer control.

Table 48 shows the configuration for a USR pin through its associated bit in its *UDIR* register. Values read from and written into the GPIO ports use the data registers **USR70**. Note: After reset, all USR pins are defaulted as inputs and pulled up to VDD until any write to the corresponding UDIR register is performed. This insures all USR pins are set to a known value until set by the firmware. Unused USR pins can be set for output if unused and unconnected to prevent them from floating. Alternatively, unused USR pins can be set for input and tied to ground or V_{DD}.

Table 47: Direction Registers and Internal Resources for DIO Pin Groups

| USR Pin Group | Type | Direction Register Name | Direction Register (SFR) Location | Data Register Name | Data Register (SFR) Location |
|---------------|-----------|-------------------------|-----------------------------------|--------------------|------------------------------|
| USR_0...USR_7 | Multi-use | UDIR70 | 0x91 [7:0] | USR70 | 0x90 [7:0] |

Table 48: UDIR Control Bit

| | UDIR Bit | |
|------------------|----------|-------|
| | 0 | 1 |
| USR Pin Function | output | input |

Four XRAM SFR registers (**USRIntCtl1**, **USRIntCtl2**, **USRIntCtl3**, and **USRIntCtl4**) control the use of the USR [7:0] pins. Each of the USR [7:0] pins can be configured as GPIO or individually be assigned an internal resource such as an interrupt or a timer/counter control. Each of the four registers contains two 3-bit configuration words named UxIS (where x corresponds to the USR pin). The control resources selectable for the USR pins are listed in Table 74 through Table 78. If more than one input is connected to the same resource, the resources are combined using a logical OR.

Table 49: Selectable Controls Using the UxIS Bits

| UxIS Value | Resource Selected for USRx Pin |
|------------|--|
| 0 | None |
| 1 | None |
| 2 | T0 (counter0 gate/clock) |
| 3 | T1 (counter1 gate/clock) |
| 4 | Interrupt 0 rising edge/high level on USRx |
| 5 | Interrupt 1 rising edge/high level on USRx |
| 6 | Interrupt 0 falling edge/low level on USRx |
| 7 | Interrupt 1 falling edge/low level on USRx |

Note: x denotes the corresponding USR pin. Interrupt edge or level control is assigned in the IT0 and IT1 bits in the **TCON** register.

External Interrupt Control Register (USRIntCtl1) : 0xFF90 ← 0x00

Table 50: The USRIntCtl1 Register

| | | | | | | | | |
|-----|--------|--------|--------|---|--------|--------|--------|-----|
| MSB | | | | | | | | LSB |
| – | U1IS.6 | U1IS.5 | U1IS.4 | – | U0IS.2 | U0IS.1 | U0IS.0 | |

External Interrupt Control Register (USRIntCtl2) : 0xFF91 ← 0x00

Table 51: The USRIntCtl2 Register

| | | | | | | | | |
|-----|--------|--------|--------|---|--------|--------|--------|-----|
| MSB | | | | | | | | LSB |
| – | U3IS.6 | U3IS.5 | U3IS.4 | – | U2IS.2 | U2IS.1 | U2IS.0 | |

External Interrupt Control Register (USRIntCtl3) : 0xFF92 ← 0x00

Table 52: The USRIntCtl3 Register

| | | | | | | | | |
|-----|--------|--------|--------|---|--------|--------|--------|-----|
| MSB | | | | | | | | LSB |
| – | U5IS.6 | U5IS.5 | U5IS.4 | – | U4IS.2 | U4IS.1 | U4IS.0 | |

External Interrupt Control Register (USRIntCtl4) : 0xFF93 ← 0x00

Table 53: The USRIntCtl4 Register

| | | | | | | | | |
|-----|--------|--------|--------|---|--------|--------|--------|-----|
| MSB | | | | | | | | LSB |
| – | U7IS.6 | U7IS.5 | U7IS.4 | – | U6IS.2 | U6IS.1 | U6IS.0 | |

1.7.10 Real-Time Clock with Hardware Watchdog (RTC)

Figure 10 shows the block diagram of the Real Time Clock. The RTC block uses the 32768Hz oscillator signal and divider logic to produce 0.5-second time marks. The time marks are used to create interrupts at intervals from 0.5 seconds to 8 seconds as selected by RTC Interval (RTCINV(2:0)). The 32768Hz oscillator can be disabled but is intended to operate at all times and in all power consumption modes. If a 32kHz crystal is not provided, the 32 kHz oscillator should be disabled and the RTC will operate from MCLK (96MHz) divided by 2930 (refer to the oscillator and clock generation section). The clock generated by the high speed oscillator will not yield exactly 32768 Hz, but a frequency of approximately 32764.505119 Hz. This yields a negative 106.6 PPM ($1 / 9375$) error with respect to 32768Hz. The RTC circuit provides hardware to compensate for this error by providing an offset circuit that will adjust the RTC counter.

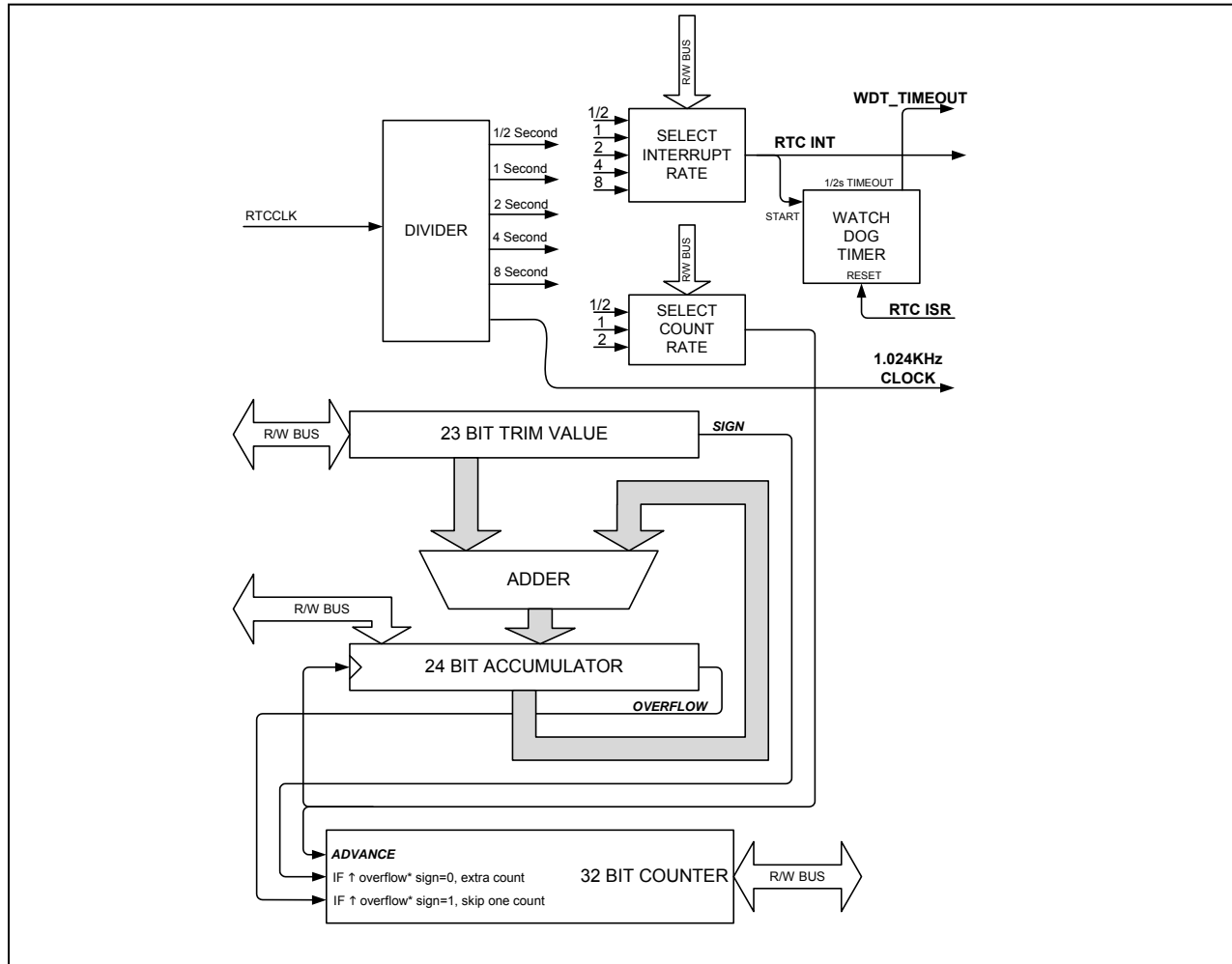

Figure 10: Real Time Clock Block Diagram

A 32-bit RTC counter is clocked by a selectable clock (1/2, 1, 2 second) to measure time. A trimming function is provided such that a trim value is accumulated in a 24-bit accumulator at the same rate as the RTC counter. The trim value is sign magnitude number. When the accumulator reaches overflow, it will advance the counter one additional count if the trim value is positive, or prevent the counter from advancing one count if the trim value is negative. This mechanism allows the RTC counter to be adjusted to keep accurate time with a minimum 0.5 second resolution. When using the high speed oscillator, the RTC counter wants to have an extra count added every 9375 seconds to keep the RTC counter at the proper time. If the one second RTC counter rate is used, the RTC Trim value should be set to 0x6FD (1789 decimal). This value is derived by taking the resolution of the 24 bit accumulator ($2^{24} = 16777216$) and dividing this by 9375. This means the RTC accumulator will overflow every 9375 seconds and will cause the RTC counter to advance by 2 when the accumulator overflow occurs, thus bringing the RTC count to the proper time.

In addition to the basic software watchdog timer included in the 80515 MPU, an independent, robust, fixed-duration, hardware watchdog timer (WDT) is included with the 73S1217F RTC. The Watch Dog timer will give the MPU $\frac{1}{2}$ second to respond to the RTC Interrupt. If the processor does not perform an RTC Interrupt service, a full RESET will be performed. The RTC interrupt is connected to the core interrupt "external interrupt 5" signal. The RTC interrupt must be enabled to obtain the watchdog timer function. Note: if the power down mode doesn't want the watchdog to wake up the MPU, the RTC interrupt should be masked before entering the power down mode.

Real Time Clock Control Register (RTCCtl) : 0x FFB0 ← 0x00

Table 54: The RTCCtl Register

| MSB | | | | | | | | LSB |
|-----|--|-------|---------|---------|--------|--------|--------|-----|
| | | | | | | | | |
| | | RTCLD | CTSEL.1 | CTSEL.0 | RINT.2 | RINT.1 | RINT.0 | |

| Bit | Symbol | Function |
|----------|---------|--|
| RTCCtl.7 | – | |
| RTCCtl.6 | – | |
| RTCCtl.5 | RTCLD | When set, RTC parameters (RTC Count, RTC Accumulator, and RTC Trim) are loaded at the next 32kHz clock positive edge. |
| RTCCtl.4 | CTSEL.1 | Selects the time value that is counted by the real time clock: 0x – 1 second (default) 10 – $\frac{1}{2}$ second 11 – 2 seconds |
| RTCCtl.3 | CTSEL.0 | |
| RTCCtl.2 | RINT.2 | |
| RTCCtl.1 | RINT.1 | RTC interrupt internal selection bits: (listed as bits 2,1,0) 100 – 0.5 second 0xx – 1 second (default) 101 – 2 seconds |
| RTCCtl.0 | RINT.0 | |
| | | 110 – 4 seconds 111 – 8 seconds |

There are 3 sets of registers to load the RTC 24-bit accumulator, 32-bit counter and 23-bit trim registers. The registers are loaded when the RTCLD bit is set in [RTCCtl](#).

Table 55: The 32-bit RTC Counter

| | | | | |
|----------|---------------|---------------|--------------|-------------|
| Register | RTCCnt3 | RTCCnt2 | RTCCnt1 | RTCCnt0 |
| | RTCCnt[31:24] | RTCCnt[23:16] | RTCCnt[15:8] | RTCCnt[7:0] |

Table 56: The 24-bit RTC Accumulator

| | | | | |
|----------|--|----------------|---------------|--------------|
| Register | | RTCACC2 | RTCACC1 | RTCACC0 |
| | | RTCACC [23:16] | RTCACC [15:8] | RTCACC [7:0] |

Table 57: The 24-bit RTC Trim (sign magnitude value)

| | | | | |
|----------|--|-----------------|----------------|---------------|
| Register | | RTCTrim2 | RTCTrim1 | RTCTrim0 |
| | | RTCTrim [23:16] | RTCTrim [15:8] | RTCTrim [7:0] |

External Interrupt Control Register (INT5Ctl): 0xFF94 ← 0x00

Table 58: The INT5Ctl Register

| | | | | | | | |
|-------|---|--------|--------|--------|--------|-------|-------|
| MSB | | | | LSB | | | |
| PDMUX | – | RTCIEN | RTCINT | USBIEN | USBINT | KPIEN | KPINT |

| Bit | Symbol | Function |
|-----------|--------|--|
| INT5Ctl.7 | PDMUX | Power down multiplexer control. |
| INT5Ctl.6 | – | |
| INT5Ctl.5 | RTCIEN | When set =1, enables RTC interrupt. Note: The RTC based watchdog will be enabled when set. |
| INT5Ctl.4 | RTCINT | When set =1, indicates interrupt from Real Time Clock function. Cleared on read of register. |
| INT5Ctl.3 | USBIEN | USB interrupt enable. |
| INT5Ctl.2 | USBINT | USB interrupt flag. |
| INT5Ctl.1 | KPIEN | Keypad interrupt enable. |
| INT5Ctl.0 | KPINT | Keypad interrupt flag. |

1.7.11 Analog Voltage Comparator

The 73S1217F includes a programmable comparator that is connected to the ANA_IN pin. The comparator can be configured to trigger an interrupt if the input voltage rises above or falls below a selectable threshold voltage. The comparator control register should not be modified when the analog interrupt (ANAIEN bit in the [INT6Ctl](#) register) is enabled to guard against any false interrupt that might be generated when modifying the threshold. The comparator has a built-in hysteresis to prevent the comparator from repeatedly responding to low-amplitude noise. This hysteresis is approximately 20mV. The maximum voltage on the ANA_IN pad should be less than 3 volts. An external resistor divider is required for detecting voltages greater than 3.0 volts. Interrupt control is handled in the [INT6Ctl](#) register.

Analog Compare Control Register (ACOMP): 0xFFD0 ← 0x00

Table 59: The ACOMP Register

| MSB | | | | | | | | LSB | |
|---------|--------|---|------|-------|---|--------|--------|-----|--|
| ANALVL | – | ONCHG | CPOL | CMPEN | 0 | TSEL.1 | TSEL.0 | | |
| Bit | Symbol | Function | | | | | | | |
| ACOMP.7 | ANALVL | When read, indicates whether the input level is above or below the threshold. This is a real time value and is not latched, so it may change from the time of the interrupt trigger until read. | | | | | | | |
| ACOMP.6 | – | | | | | | | | |
| ACOMP.5 | ONCHG | If set, the Ana_interrupt is invoked on any change above or below the threshold, bit 4 is ignored. | | | | | | | |
| ACOMP.4 | CPOL | If set = 1, Ana_interrupt is invoked when signal rises above selected threshold. If set = 0, Ana_interrupt is invoked when signal goes below selected threshold (default). | | | | | | | |
| ACOMP.3 | CMPEN | Enables power to the analog comparator. 1= Enabled. 0 = Disabled (default). | | | | | | | |
| ACOMP.2 | 0 | This value must be fixed at 0. | | | | | | | |
| ACOMP.1 | TSEL.1 | Sets the voltage threshold for comparison to the voltage on pin ANA_IN. Thresholds are as follows: 00 = 1.00V 01 = 1.24V 10 = 1.40V 11 = 1.50V | | | | | | | |
| ACOMP.0 | TSEL.0 | | | | | | | | |

External Interrupt Control Register (INT6Ctl): 0xFF95 ← 0x00**Table 60: The INT6Ctl Register**

| MSB | | | | | | | | LSB |
|-----------|--------|--|--------|--------|--------|--------|-------|-------|
| | – | – | VFTIEN | VFTINT | I2CIEN | I2CINT | ANIEN | ANINT |
| Bit | Symbol | Function | | | | | | |
| INT6Ctl.7 | – | | | | | | | |
| INT6Ctl.6 | – | | | | | | | |
| INT6Ctl.5 | VFTIEN | VDD fault interrupt enable. | | | | | | |
| INT6Ctl.4 | VFTINT | VDD fault interrupt flag. | | | | | | |
| INT6Ctl.3 | I2CIEN | I ² C interrupt enabled. | | | | | | |
| INT6Ctl.2 | I2CINT | I ² C interrupt flag. | | | | | | |
| INT6Ctl.1 | ANIEN | If ANIEN = 1 Analog Compare event interrupt is enabled. When masked (ANIEN = 0), ANINT (bit 0) may be set, but no interrupt is generated. | | | | | | |
| INT6Ctl.0 | ANINT | (Read Only) Set when the selected ANA_IN signal changes with respect to the selected threshold if Compare_Enable is asserted. Cleared on read of register. | | | | | | |

1.7.12 LED Driver

The 73S1217F provides a single dedicated output pin for driving an LED. The LED driver pin can be configured as a current source that will pull to ground to drive an LED that is connected to VDD without the need for an external current limiting resistor. This pin may be used as general purpose output with the programmed pull-down current and a strong (CMOS) pull-up, if enabled. The analog block must be enabled when this output is being used to drive the selected output current.

This pin may be used as an input with consideration of the programmed output current and level. The register bit when read, indicates the state of the pin.

LED Control Register (LEDctl): 0xFFF3 ← 0xFF

Table 61: The LEDctl Register

| MSB | | | | | | | | LSB |
|----------|--------|--|--------|--------|-------|-------|--------|-------|
| | – | LPUEN | ISET.1 | ISET.0 | LEDD3 | LEDD2 | LEDD 1 | LEDD0 |
| Bit | Symbol | Function | | | | | | |
| LEDctl.7 | – | | | | | | | |
| LEDctl.6 | LPUEN | 0 = Pull-up is enabled for the LED pin. | | | | | | |
| LEDctl.5 | ISET.1 | These two bits control the drive current (to ground) for the LED driver pin. Current levels are: 00 = 0ma(off) 01 = 2ma 10 = 4ma 11 = 10ma | | | | | | |
| LEDctl.4 | ISET.0 | | | | | | | |
| LEDctl.3 | – | | | | | | | |
| LEDctl.2 | – | | | | | | | |
| LEDctl.1 | – | | | | | | | |
| LEDctl.0 | LEDD0 | Write data controls output level of pin LED0. Read will report level of pin LED0. | | | | | | |

1.7.13 I²C Master Interface

The 73S1217F includes a dedicated fast mode, 400kHz I²C Master interface. The I²C interface can read or write 1 or 2 bytes of data per data transfer frame. The MPU communicates with the interface through six dedicated SFR registers:

- Device Address ([DAR](#))
- Write Data ([WDR](#))
- Secondary Write Data ([SWDR](#))
- Read Data ([RDR](#))
- Secondary Read Data ([SRDR](#))
- Control and Status ([CSR](#))

The [DAR](#) register is used to set up the slave address and specify if the transaction is a read or write operation. The [CSR](#) register sets up, starts the transaction and reports any errors that may occur. When the I²C transaction is complete, the I²C interrupt is reported via external interrupt 6. The I²C interrupt is automatically de-asserted when a subsequent I²C transaction is started. The I²C interface uses a 400kHz clock from the time-base circuits.

1.7.13.1 I²C Write Sequence

To write data on the I²C Master Bus, the 80515 has to program the following registers according to the following sequence:

1. Write slave device address to Device Address register ([DAR](#)). The data contains 7 bits for the slave device address and 1 bit of op-code. The op-code bit should be written with a '0' to indicate a write operation.
2. Write data to Write Data register ([WDR](#)). This data will be transferred to the slave device.
3. If writing 2 bytes, set bit 0 of the Control and Status register ([CSR](#)) and load the second data byte to Secondary Write Data register ([SWDR](#)).
4. Set bit 1 of the [CSR](#) register to start I²C Master Bus.
5. Wait for I²C interrupt to be asserted. It indicates that the write on I²C Master Bus is done. Refer to information about the [INT6Ctl](#), [IEN1](#) and [IRCON](#) register for masking and flag operation.

Figure 11 shows the timing of the I²C write mode.

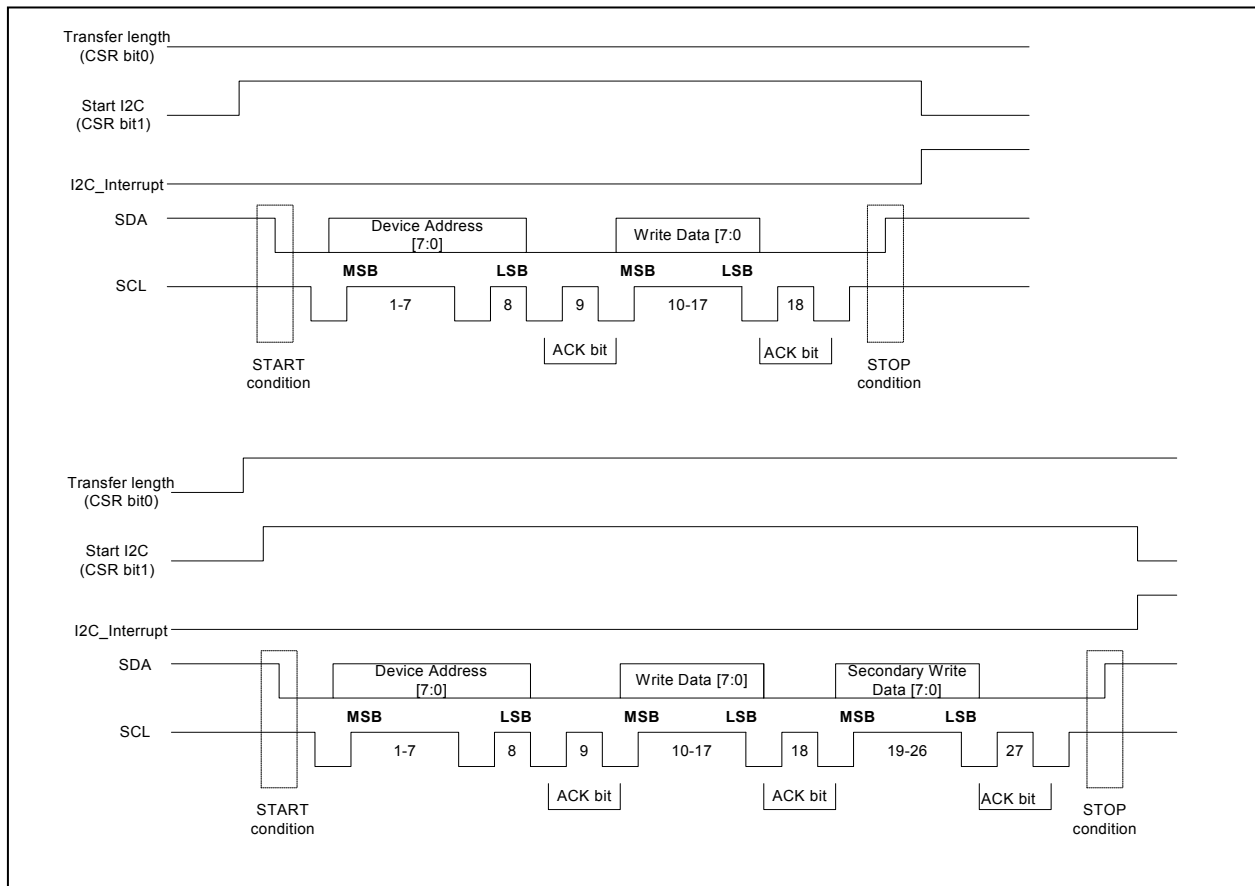

Figure 11: I²C Write Mode Operation

1.7.13.2 I²C Read Sequence

To read data on the I²C Master Bus from a slave device, the 80515 has to program the following registers in this sequence:

1. Write slave device address to the Device Address register (**DAR**). The data contains 7 bits device address and 1 bit of op-code. The op-code bit should be written with a 1.
2. Write control data to the Control and Status register (**CSR**). Write a 1 to bit 1 to start I²C Master Bus. Also write a 1 to bit 0 if the Secondary Read Data register (**SRDR**) is to be captured from the I²C Slave device.
3. Wait for I²C interrupt to be asserted. It indicates that the read operation on the I²C bus is done. Refer to information about the **INT6CtI**, **IEN1** and **IRCON** registers for masking and flag operation.
4. Read data from the Read Data register (**RDR**).
5. Read data from Secondary Read Data register (**SRDR**) if bit 0 of Control and Status register (**CSR**) is written with a 1.

The following diagram shows the timing of the I²C read mode.

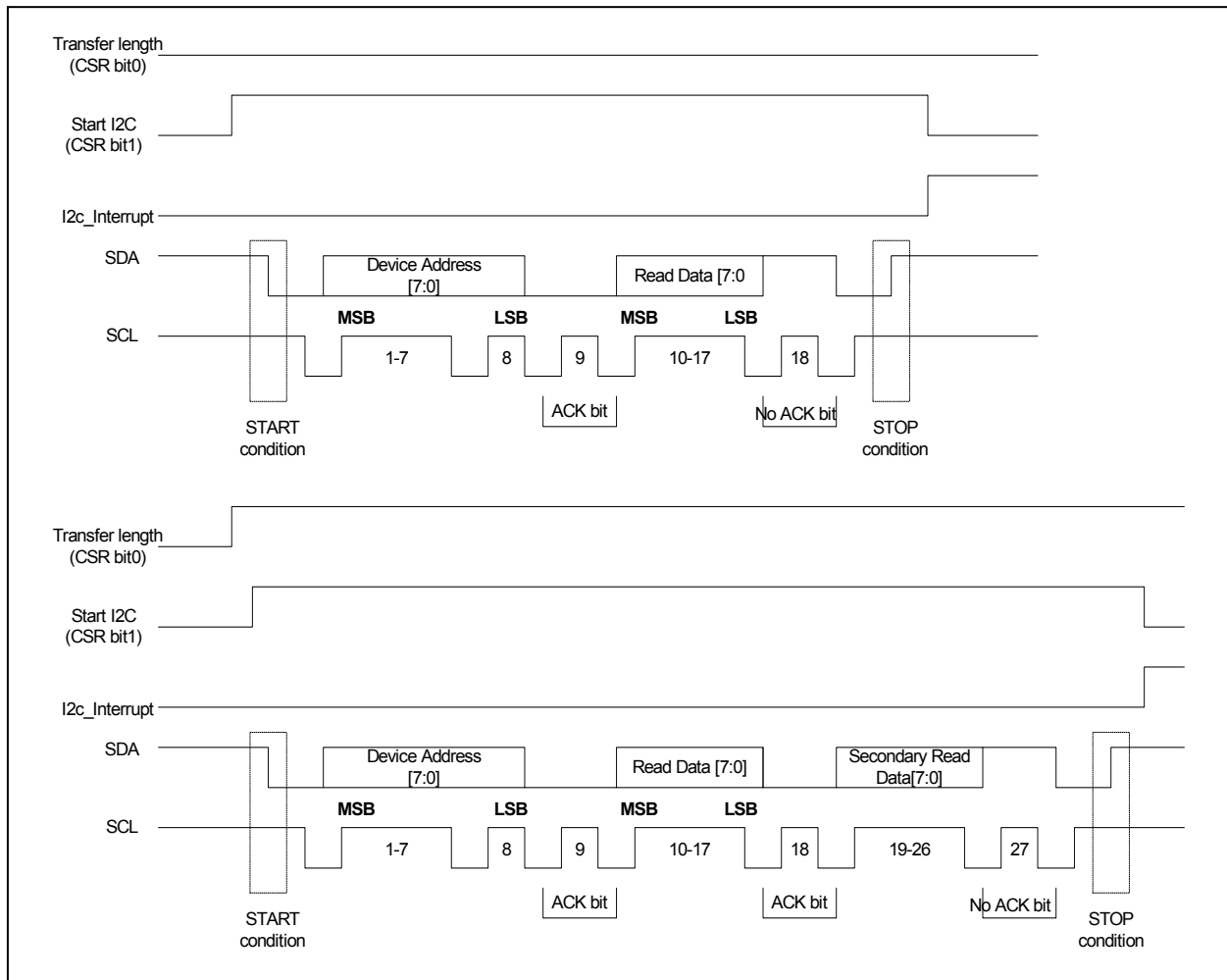

Figure 12: I²C Read Operation

Device Address Register (DAR): 0xFF80 ← 0x00**Table 62: The DAR Register**

| MSB | | | | | | | | LSB |
|---------|----------------|---|---------|---------|---------|---------|-------|-----|
| DVADR.6 | DVADR.5 | DVADR.4 | DVADR.3 | DVADR.2 | DVADR.1 | DVADR.0 | I2CRW | |
| Bit | Symbol | Function | | | | | | |
| DAR.7 | DVADR [0:6] | Slave device address. | | | | | | |
| DAR.6 | | | | | | | | |
| DAR.5 | | | | | | | | |
| DAR.4 | | | | | | | | |
| DAR.3 | | | | | | | | |
| DAR.2 | | | | | | | | |
| DAR.1 | | | | | | | | |
| DAR.0 | I2CRW | If set = 0, the transaction is a write operation. If set = 1, read. | | | | | | |

I2C Write Data Register (WDR): 0xFF81 ← 0x00**Table 63: The WDR Register**

| MSB | | | | | | | | LSB |
|-------|--|-------|-------|-------|-------|-------|-------|-----|
| WDR.7 | WDR.6 | WDR.5 | WDR.4 | WDR.3 | WDR.2 | WDR.1 | WDR.0 | |
| Bit | Function | | | | | | | |
| WDR.7 | Data to be written to the I ² C slave device. | | | | | | | |
| WDR.6 | | | | | | | | |
| WDR.5 | | | | | | | | |
| WDR.4 | | | | | | | | |
| WDR.3 | | | | | | | | |
| WDR.2 | | | | | | | | |
| WDR.1 | | | | | | | | |
| WDR.0 | | | | | | | | |

I2C Secondary Write Data Register (SWDR): 0XFF82 ← 0x00**Table 64: The SWDR Register**

| MSB | | | | LSB | | | |
|--------|--|--------|--------|--------|--------|--------|--------|
| SWDR.7 | SWDR.6 | SWDR.5 | SWDR.4 | SWDR.3 | SWDR.2 | SWDR.1 | SWDR.0 |
| Bit | Function | | | | | | |
| SWDR.7 | Second Data byte to be written to the I ² C slave device if bit 0 (I2CLEN) of the Control and Status register (CSR) is set = 1. | | | | | | |
| SWDR.6 | | | | | | | |
| SWDR.5 | | | | | | | |
| SWDR.4 | | | | | | | |
| SWDR.3 | | | | | | | |
| SWDR.2 | | | | | | | |
| SWDR.1 | | | | | | | |
| SWDR.0 | | | | | | | |

I2C Read Data Register (RDR): 0XFF83 ← 0x00**Table 65: The RDR Register**

| MSB | | | | LSB | | | |
|-------|---|-------|-------|-------|-------|-------|-------|
| RDR.7 | RDR.6 | RDR.5 | RDR.4 | RDR.3 | RDR.2 | RDR.1 | RDR.0 |
| Bit | Function | | | | | | |
| RDR.7 | Data read from the I ² C slave device. | | | | | | |
| RDR.6 | | | | | | | |
| RDR.5 | | | | | | | |
| RDR.4 | | | | | | | |
| RDR.3 | | | | | | | |
| RDR.2 | | | | | | | |
| RDR.1 | | | | | | | |
| RDR.0 | | | | | | | |

External Interrupt Control Register (INT6Ctl): 0xFF95 ← 0x00**Table 68: The INT6Ctl Register**

| MSB | | | | | | | | LSB |
|-----------|--------|---|--------|--------|--------|--------|-------|-------|
| | – | – | VFTIEN | VFTINT | I2CIEN | I2CINT | ANIEN | ANINT |
| Bit | Symbol | Function | | | | | | |
| INT6Ctl.7 | – | | | | | | | |
| INT6Ctl.6 | – | | | | | | | |
| INT6Ctl.5 | VFTIEN | VDD fault interrupt enable. | | | | | | |
| INT6Ctl.4 | VFTINT | VDD fault interrupt flag. | | | | | | |
| INT6Ctl.3 | I2CIEN | When set = 1, the I ² C interrupt is enabled. | | | | | | |
| INT6Ctl.2 | I2CINT | When set =1, the I ² C transaction has completed. Cleared upon the start of a subsequent I ² C transaction. | | | | | | |
| INT6Ctl.1 | ANIEN | Analog compare interrupt enable. | | | | | | |
| INT6Ctl.0 | ANINT | Analog compare interrupt flag. | | | | | | |

1.7.14 Keypad Interface

The 73S1217F supports a 30-button (6 row x 5 column) keypad (SPST Mechanical Contact Switches) interface using 11 dedicated I/O pins. Figure 13 shows a simplified block diagram of the keypad interface.

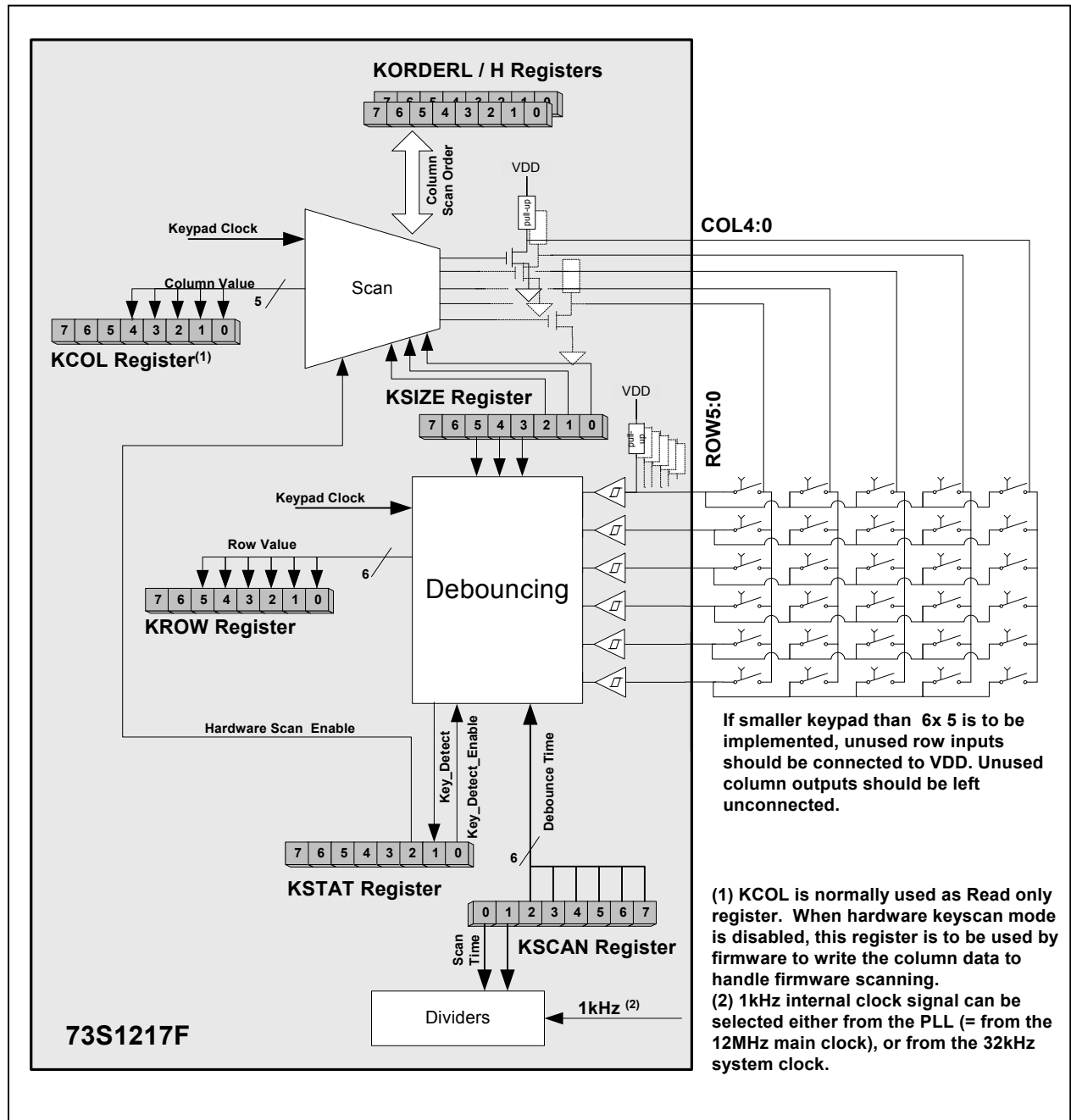

Figure 13: Simplified Keypad Block Diagram

There are five drive lines (outputs) corresponding to columns and six sense lines (inputs) corresponding to rows. Hysteresis and pull-ups are provided on all inputs (rows), which eliminate the need for external resistors in the keypad. Key scanning happens by asserting one of the 5 column lines low and looking for a low on a sense line indicating that a key is pressed (switch closed) at the intersection of the drive/sense (column/row) line in the keypad. Key detection is performed by hardware with an incorporated debounce timer. Debouncing time is adjustable through the [KSCAN](#) register. Internal hardware circuitry performs

column scanning at an adjustable scanning rate and column scanning order through registers **KSCAN** and **KORDERL / KORDERH**. Key scanning is disabled at reset and must be enabled by firmware. When a valid key is detected, an interrupt is generated and the valid value of the pressed key is automatically written into the **KCOL** and **KROW** registers. The keypad interface uses a 1kHz clock derived from either the 32768Hz crystal or the 12MHz crystal. The selection of the clock source is made external to this block, by setting bit 3 – 32KBEN – in the **MCLKCTI** register, see the oscillator and clock generation section). Disabling the 32kHz oscillator will source the 1kHz clock from the 12MHz main oscillator and divide it down. Setting bit 6 – KBEN – in the **MCLKCTI** register will enable keypad scanning and debouncing. The keypad size can be adjusted within the **KSIZE** register.

Normal scanning is performed by hardware when the bit SCNEN is set at 1 in the **KSTAT** register. **Figure 14** shows the flowchart of how the hardware scanning operates. In order to minimize power, scanning does not occur until a key-press is detected. Once hardware key scanning is enabled, the hardware drives all column outputs low and waits for a low to be detected on one of the inputs. When a low is detected on any row, and before key scanning starts, the hardware checks that the low level is still detected after a debounce time. The debounce time is defined by firmware in the **KSCAN** register (bits 7:0, DBTIME). Debounce times from 4ms to 256ms in 4ms increments are supported. If a key is not pressed after the debounce time, the hardware will go back to looking for any input to be low. If a key is confirmed to be pressed, key scanning begins.

Key scanning asserts one of the 5 drive lines (COL 4:0) low and looks for a low on a sense line indicating that a key is pressed at the intersection of the drive/sense line in the keypad. After all sense lines have been checked without a key-press being detected, the next column line is asserted. The time between checking each sense line is the scan time and is defined by firmware in the **KSCAN** register (bits 0:1 – SCTIME). Scan times from 1ms to 4ms are supported. Scanning order does not affect the scan time. This scanning continues until the entire keypad is scanned. If only one key is pressed, a valid key is detected. Simultaneous key presses are not considered as valid (If two keys are pressed, no key is reported to firmware).

Possible scrambling of the column scan order is provided by means of the **KORDERL** and **KORDERH** registers that define the order of column scanning. Values in these registers must be updated every time a new keyboard scan order is desired. It is not possible to change the order of scanning the sense lines. The column and row intersection for the detected valid key are stored in the **KCOL** and **KROW** registers. When a valid key is detected, an interrupt is generated. Firmware can then read those registers to determine which key had been pressed. After reading the **KCOL** and **KROW** registers, the firmware can update the **KORDERL / KORDERH** registers if a new scan order is needed.

When the SCNEN bit is enabled in the **KSTAT** register, the **KCOL** and **KROW** registers are only updated after a valid key has been identified. The hardware does not wait for the firmware to service the interrupt in order to proceed with the key scanning process. Once the valid key (or invalid key – e.g. two keys pressed) is detected, the hardware waits for the key to be released. Once the key is released, the debounce timer is started. If the key is not still released after the debounce time, the debounce counter starts again. After a key release, all columns will be driven low as before and the process will repeat waiting for any key to be pressed.

When the SCNEN bit is disabled, all drive outputs are set to the value in the **KCOL** register. If firmware clears the SCNEN bit in the middle of a key scan, the **KCOL** register contains the last value stored in there which will then be reflected on the output pins.

A bypass mode is provided so that the firmware can do the key scanning manually (SCNEN bit must be cleared). In bypass mode, the firmware writes/reads the Column and Row registers to perform the key scanning.

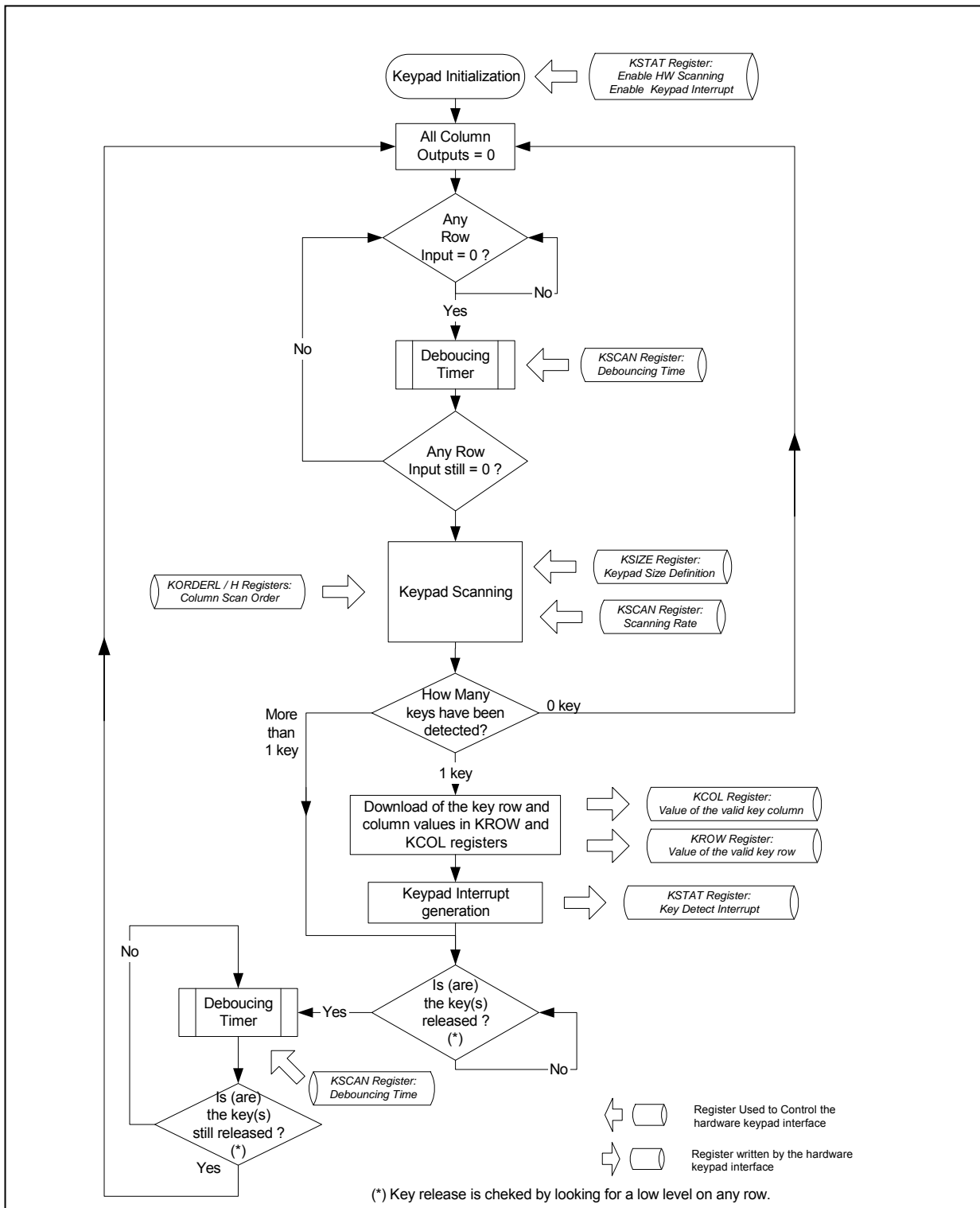

Figure 14: Keypad Interface Flow Chart

Keypad Column Register (KCOL): 0xD1 ← 0x1F

This register contains the value of the column of a key detected as valid by the hardware. In bypass mode, this register firmware writes directly this register to carry out manual scanning.

Table 69: The KCOL Register

| | | | | | | | | | |
|-----|---|---|---|-------|-------|-------|-------|-------|-----|
| MSB | – | – | – | COL.4 | COL.3 | COL.2 | COL.1 | COL.0 | LSB |
|-----|---|---|---|-------|-------|-------|-------|-------|-----|

| Bit | Symbol | Function |
|--------|--------|---|
| KCOL.7 | – | |
| KCOL.6 | – | |
| KCOL.5 | – | |
| KCOL.4 | COL.4 | Drive lines bit mapped to corresponding with pins COL(4:0). When a key is detected, firmware reads this register to determine column. In bypass (S/W keyscan) mode, Firmware writes this register directly. 0x1E = COL(0) low, all others high. 0x0F = COL(4) low, all others high. 0x1F = COL(4:0) all high. |
| KCOL.3 | COL.3 | |
| KCOL.2 | COL.2 | |
| KCOL.1 | COL.1 | |
| KCOL.0 | COL.0 | |

Keypad Row Register (KROW): 0xD2 ← 0x3F

This register contains the value of the row of a key detected as valid by the hardware. In bypass mode, this register firmware reads directly this register to carry out manual detection.

Table 70: The KROW Register

| | | | | | | | | | |
|-----|---|---|-------|-------|-------|-------|-------|-------|-----|
| MSB | – | – | ROW.5 | ROW.4 | ROW.3 | ROW.2 | ROW.1 | ROW.0 | LSB |
|-----|---|---|-------|-------|-------|-------|-------|-------|-----|

| Bit | Symbol | Function |
|--------|--------|--|
| KROW.7 | – | |
| KROW.6 | – | |
| KROW.5 | ROW.6 | Sense lines bit mapped to correspond with pins ROW(5:0). When key detected, firmware reads this register to determine row. In bypass mode, firmware reads rows and has to determine if there was a key press or not. 0x3E = ROW(0) low, all others high. 0x1F = ROW(5) low, all others high. 0x3F = ROW(5:0) all high. |
| KROW.4 | ROW.4 | |
| KROW.3 | ROW.3 | |
| KROW.2 | ROW.2 | |
| KROW.1 | ROW.1 | |
| KROW.0 | ROW.0 | |

Keypad Scan Time Register (KSCAN): 0xD3 ← 0x00

This register contains the values of scanning time and debouncing time.

Table 71: The KSCAN Register

| MSB | | | | | LSB | | |
|----------|----------|---|----------|----------|----------|----------|----------|
| DBTIME.5 | DBTIME.4 | DBTIME.3 | DBTIME.2 | DBTIME.1 | DBTIME.0 | SCTIME.1 | SCTIME.0 |
| Bit | Symbol | Function | | | | | |
| KSCAN.7 | DBTIME.5 | De-bounce time in 4ms increments. 1 = 4ms de-bounce time, 0x3F = 252ms, 0x00 = 256ms. Key presses and key releases are de-bounced by this amount of time. | | | | | |
| KSCAN.6 | DBTIME.4 | | | | | | |
| KSCAN.5 | DBTIME.3 | | | | | | |
| KSCAN.4 | DBTIME.2 | | | | | | |
| KSCAN.3 | DBTIME.1 | | | | | | |
| KSCAN.2 | DBTIME.0 | | | | | | |
| KSCAN.1 | SCTIME.1 | Scan time in ms. 01 = 1ms, 02 = 2ms, 00 = 3ms, 00 = 4ms. Time between checking each key during keypad scanning. | | | | | |
| KSCAN.0 | SCTIME.0 | | | | | | |

Keypad Scan Time Register (KSIZE): 0xD5 ← 0x00

This register is not applicable when HWSCEN is not set. Unused row inputs should be connected to VDD.

Table 73: The KSIZE Register

| | | | | | | | |
|-----|---|----------|----------|----------|----------|----------|----------|
| MSB | | | | LSB | | | |
| – | – | ROWSIZ.2 | ROWSIZ.1 | ROWSIZ.0 | COLSIZ.2 | COLSIZ.1 | COLSIZ.0 |

| Bit | Symbol | Function |
|---------|----------|---|
| KSIZE.7 | – | |
| KSIZE.6 | – | |
| KSIZE.5 | ROWSIZ.2 | Defines the number of rows in the keypad. Maximum number is 6 given the number of row pins on the package. Allows for a reduced keypad size for scanning. |
| KSIZE.4 | ROWSIZ.1 | |
| KSIZE.3 | ROWSIZ.0 | |
| KSIZE.2 | COLSIZ.2 | Defines the number of columns in the keypad. Maximum number is 5 given the number of column pins on the package. Allows for a reduced keypad size for scanning. |
| KSIZE.1 | COLSIZ.1 | |
| KSIZE.0 | COLSIZ.0 | |

Keypad Column LS Scan Order Register (KORDERL): 0xD6 ← 0x00

In the KORDERL and KORDERH registers, Column Scan Order(14:0) is grouped into 5 sets of 3 bits each. Each set determines which column (COL(4:0) pin) to activate by loading the column number into the 3 bits. When in HW_Scan_Enable mode, the hardware will step through the sets from 1Col to 5Col (up to the number of columns in Colsize) and scan the column defined in the 3 bits. To scan in sequential order, set a counting pattern with 0 in set 0, and 1 in set 1, and 2 in set 2, and 3 in set 3, and 4 in set 4. The firmware should update this as part of the interrupt service routine so that the new scan order is loaded prior to the next key being pressed. For example, to scan COL(0) first, 1Col(2:0) should be loaded with 000'b. To scan COL(4) fifth, 5Col(2:0) should be loaded with 100'b.

Table 74: The KORDERL Register

| | | | | | | | |
|--------|--------|--------|--------|--------|--------|--------|--------|
| MSB | | | | | LSB | | |
| 3COL.1 | 3COL.0 | 2COL.2 | 2COL.1 | 2COL.0 | 1COL.2 | 1COL.1 | 1COL.0 |

| Bit | Symbol | Function |
|-----------|--------|---|
| KORDERL.7 | 3COL.1 | Column to scan 3 rd (lsb's). |
| KORDERL.6 | 3COL.0 | |
| KORDERL.5 | 2COL.2 | Column to scan 2 nd . |
| KORDERL.4 | 2COL.1 | |
| KORDERL.3 | 2COL.0 | |
| KORDERL.2 | 1COL.2 | Column to scan 1 st . |
| KORDERL.1 | 1COL.1 | |
| KORDERL.0 | 1COL.0 | |

Keypad Column MS Scan Order Register (KORDERH): 0xD7 ← 0x00**Table 75: The KORDERH Register**

| MSB | | | | LSB | | | |
|-----|--------|--------|--------|--------|--------|--------|--------|
| – | 5COL.2 | 5COL.1 | 5COL.0 | 4COL.2 | 4COL.1 | 4COL.0 | 3COL.2 |

| Bit | Symbol | Function |
|-----------|--------|---|
| KORDERH.7 | – | |
| KORDERH.6 | 5COL.2 | Column to scan 5 th . |
| KORDERH.5 | 5COL.1 | |
| KORDERH.4 | 5COL.0 | |
| KORDERH.3 | 4COL.2 | Column to scan 4 th . |
| KORDERH.2 | 4COL.1 | |
| KORDERH.1 | 4COL.0 | |
| KORDERH.0 | 3COL.2 | Column to scan 3 rd (msb's). |

External Interrupt Control Register (INT5Ctl): 0xFF94 ← 0x00**Table 76: The INT5Ctl Register**

| MSB | | | | LSB | | | |
|-------|---|-------|--------|--------|--------|-------|-------|
| PDMUX | – | RTCEN | RTCINT | USBIEN | USBINT | KPIEN | KPINT |

| Bit | Symbol | Function |
|-----------|--------|---|
| INT5Ctl.7 | PDMUX | Power down multiplexer control. |
| INT5Ctl.6 | – | |
| INT5Ctl.5 | RTCEN | When set =1, enables RTC interrupt. |
| INT5Ctl.4 | RTCINT | When set =1, indicates interrupt from Real Time Clock function. Cleared on read of register. |
| INT5Ctl.3 | USBIEN | USB interrupt enable. |
| INT5Ctl.2 | USBINT | USB interrupt flag. |
| INT5Ctl.1 | KPIEN | Enables Keypad interrupt when set = 1. |
| INT5Ctl.0 | KPINT | This bit indicates the Keypad logic has set Key_Detect bit and a key location may be read. Cleared on read of register. |

1.7.15 Emulator Port

The emulator port, consisting of the pins E_RST, E_TCLK and E_RXTX, provides control of the MPU through an external in-circuit emulator. The E_TBUS[3:0] pins, together with the E_ISYNC/BRKRQ, add trace capability to the emulator. The emulator port is compatible with the ADM51 emulators manufactured by Signum Systems.

If code trace capability is needed on this interface, 20pF capacitors (to ground) need to be added to allow the trace function capability to run properly. These capacitors should be attached to the TBUS0:3 and ISBR signals.

1.7.16 USB Interface

The 73S1217F provides a single interface, full speed -12Mbps - USB device port as per the *Universal Serial Bus Specification, Revision 2.0* (backward compatible with USB 1.1). USB circuitry gathers the transceiver, the Serial Interface Engine (SIE), and the data buffers. An internal pull-up to V_{DD} on D+ indicates that the device is a full speed device attached to the USB bus (allows full speed recognition by the host without adding any external components). When using the USB interface, V_{DD} must be between 3.0V – 3.6V in order to meet the USB VOH requirement. The interface is highly configurable under firmware control. Control (Endpoint 0), Interrupt IN, Bulk IN and Bulk OUT transfers are supported. Four endpoints are supported and are configured by firmware:

- Endpoint 0, the default (Control) endpoint as required by the USB specification, is used to exchange control and status information between the 73S1217F and the USB host.
- Bulk IN Endpoint #1
- Bulk OUT Endpoint #1
- Interrupt IN Endpoint #2
- The USB block contains several FIFOs used for communication.
- There is a 128-byte RAM FIFO for each BULK endpoint. Maximum Bulk packet size is 64 bytes.
- There is a 32-byte RAM FIFO for the interrupt endpoint. Maximum Interrupt packet size is 16 bytes.
- There is a 16-byte RAM FIFO for the control endpoint. Maximum Control packet size is 16 bytes.

Figure 15 shows the simplified block diagram of the USB interface.

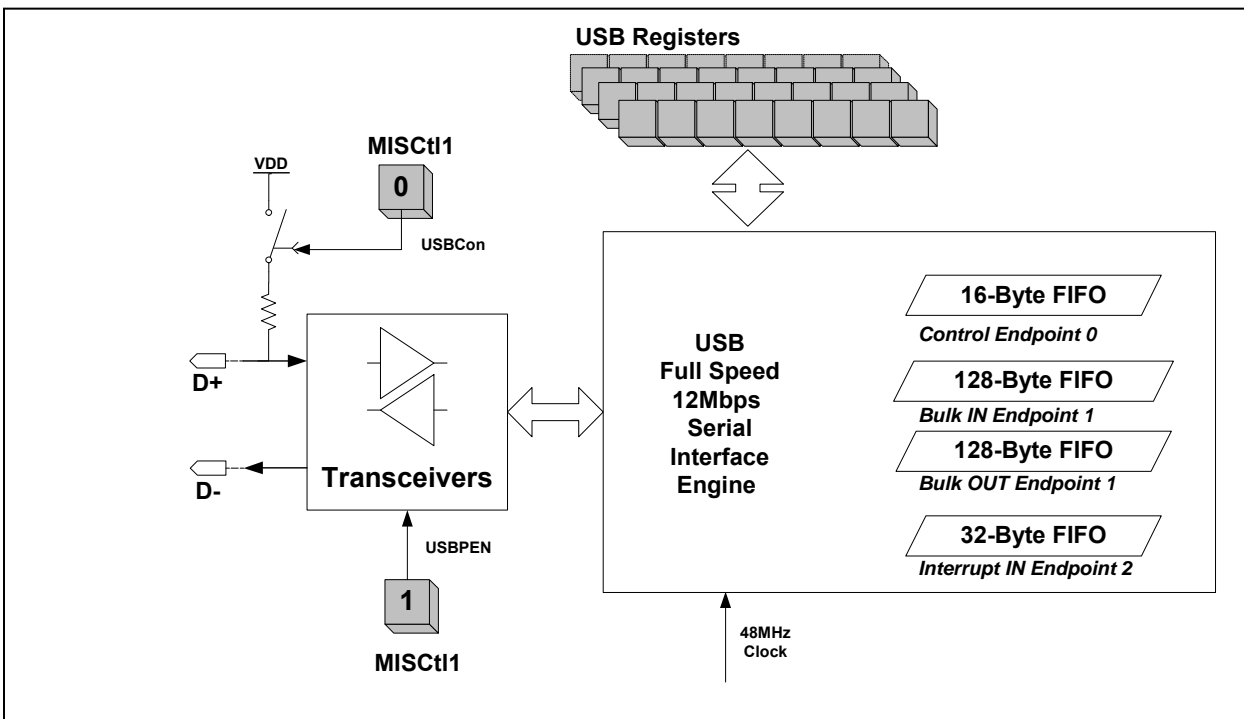

Figure 15: USB Block Diagram

The USB interface consists of a Serial Interface Engine (SIE) that handles NRZI encoding/decoding, bit stuffing / unstuffing, and CRC generation/checking. It also generates headers for packets to be transmitted and decodes the headers of received packets. An analog transceiver interfaces with the external USB bus. The USB interface hardware performs error checking and removes the USB protocol fields from the incoming messages before passing the data to the firmware. The hardware also adds the USB protocol fields to the outgoing messages coming from the firmware. The hardware implements NRZI encoding/decoding, CRC checking/generation (both on data and token packets), device address

decoding, handshake packet generation, Data0/Data1 toggle synchronization, bit stuffing, bus idle detection and other protocol generation/checking required in Chapter 8 of the USB specification.

The firmware is responsible for servicing and building the messages required under Chapter 9 of the USB specification. Device configuration is stored in the firmware. Data received from the USB port is stored in the appropriate IN FIFO that is read by the firmware and processed. The messages to be sent back to the USB host are generated by firmware and placed back into the appropriate OUT FIFO. Stall/NAK handshakes are generated as appropriate if the RAM is not available for another message from the USB host. Suspend and resume modes are supported. All register/FIFO spaces are located in Data Memory space. The FIFOs are dedicated for USB storage and are unused in a configuration that is not using USB. All registers in the USB interface are located in external data memory address (XRAM) space starting at address FC00'h.

1.7.16.1 USB Interface Implementation

The 73S1217F Application Programming Interface includes some dedicated software commands to configure the USB interface, to get a status of each USB Endpoint, to stall / unstick portions of the USB, and to send / receive data to / from each endpoint.

USB API entirely manages the USB circuitry, the USB registers and the FIFOs. Use of those commands facilitates USB implementation, without dealing with low-level programming.

Miscellaneous Control Register 1 (MISCT1): 0xFFF2 ← 0x10

Table 77: The MISCT1 Register

| MSB | | | | | | LSB | |
|-----|---|-------|--------|---|--------|--------|--------|
| – | – | FRPEN | FLSH66 | – | ANAPEN | USBPEN | USBCON |

| Bit | Symbol | Function |
|----------|--------|--|
| MISCT1.7 | – | |
| MISCT1.6 | – | |
| MISCT1.5 | FRPEN | Flash Read Pulse enable. |
| MISCT1.4 | FLSH66 | Flash Read Pulse. |
| MISCT1.3 | – | |
| MISCT1.2 | ANAPEN | Analog power enable. |
| MISCT1.1 | USBPEN | 0 = Enable the USB differential transceiver. |
| MISCT1.0 | USBCON | 1 = Connect pull-up resistor from VDD to D+. If connected, the USB host will recognize the attachment of a USB device and begin enumeration. |

Note: When using the USB on the 73S1217F, external 24Ω series resistors must be added to the D+ and D- signals to provide the proper impedance matching on these pins.

The USB peripheral block is not able to support read or write operations to the USB SFR registers when the MPU clock is running at MPU clock rates of 12MHz or greater. In order to properly communicate with the USB SFR registers when running at these speeds, wait states must be inserted when addressing the USB SFRs. The CKCON register allows wait states to be inserted when accessing these registers. The proper settings for the number of wait states are shown in **Error! Reference source not found.**



When changing the MPU clock rate or the number of wait states, the USB connection must be inactive. If the USB is active, then it must be inactivated before changing the MPU clock or number of wait states. It can then be reconnected and re-enumerated.

Changing these parameters while the USB interface is active may cause communication errors on the USB interface.

Clock Control Register (CKCON): 0x8E ← 0x01**Table 78: The CKCON Register**

| | | | | | | | | | |
|-----|---|---|---|---|---|--------|--------|--------|-----|
| MSB | - | - | - | - | - | CKWT.2 | CKWT.1 | CKWT.0 | LSB |
|-----|---|---|---|---|---|--------|--------|--------|-----|

| Bit | Symbol | Function |
|---------|--------|--|
| CKCON.7 | - | |
| CKCON.6 | - | |
| CKCON.5 | - | |
| CKCON.4 | - | |
| CKCON.3 | - | |
| CKCON.2 | CKWT.2 | These three bits determine the number of wait states (machine cycles) to insert when accessing the USB SFRs: 000 = 0 (not to be used). 001 = 1 wait state. Use when MPU clock is <12MHz. 010 = 2 wait states. Use when MPU clock is between 12 and 16MHz. 011 = 3 wait states. Use when MPU clock is 24MHz. 100 = 4 wait states. 101 = 5 wait states. 110 = 6 wait states. 111 = 7 wait states. |
| CKCON.1 | CKWT.1 | |
| CKCON.0 | CKWT.0 | |

1.7.17 Smart Card Interface Function

The 73S1217F integrates one ISO-7816 (T=0, T=1) UART, one complete ICC electrical interface as well as an external smart card interface to allow multiple smart cards to be connected using the Teridian 73S8010x family of interface devices. Figure 16 shows the simplified block diagram of the card circuitry (UART + interfaces), with detail of dedicated XRAM registers.

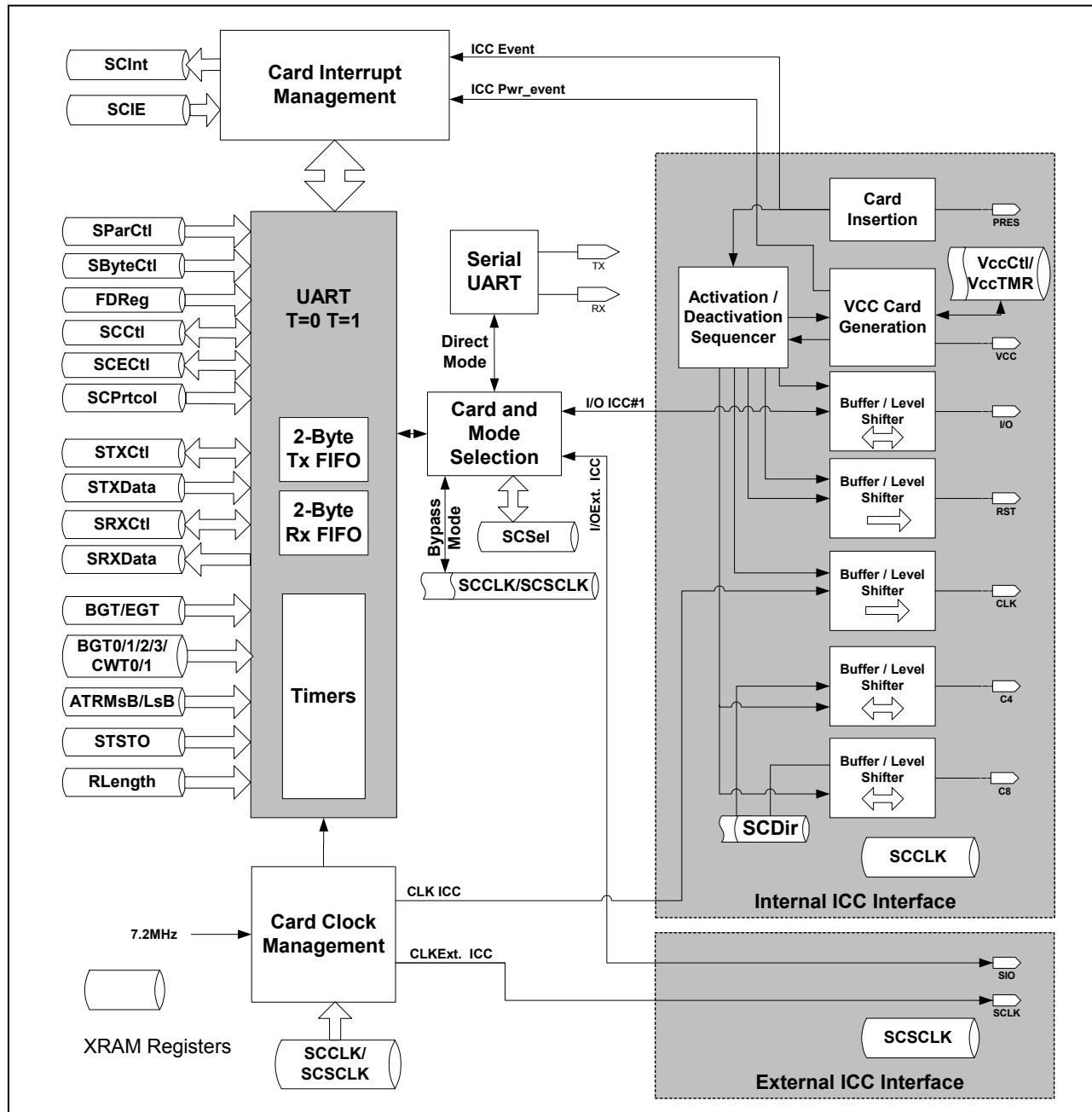

Figure 16: Smart Card Interface Block Diagram

Card interrupts are managed through two dedicated registers **SCIE** (Interrupt Enable to define which interrupt is enabled) and **SCInt** (Interrupt status). They allow the firmware to determine the source of an interrupt, that can be a card insertion / removal, card power fault, or a transmission (TX) or reception (RX) event / fault. It should be noted that even when card clock is disabled, an ICC interrupt can be generated on a card insertion / removal to allow power saving modes. Card insertion / removal is generated from the respective card switch detection inputs (whose polarity is programmable).

The built-in ICC Interface has a linear regulator (V_{CC} generator) capable of driving 1.8, 3.0 and 5.0V smart cards in accordance with the ISO 7816-3 and EMV4.0 standards. This converter uses the V_P (5.5V nominal) input supply source. See the power supply management section above for more detail. Auxiliary I/O lines C4 and C8 are only provided for the built-in interface. If support for the auxiliary lines is necessary for the external smart card interface, they need to be handled manually through the USR GPIO pins. The external 73S8010x devices directly connect the I/O (SIO) and clock (SCLK) signals and control is handled via the I²C interface.

Figure 17 shows how multiple 73S8010x devices can be connected to the 73S1217F.

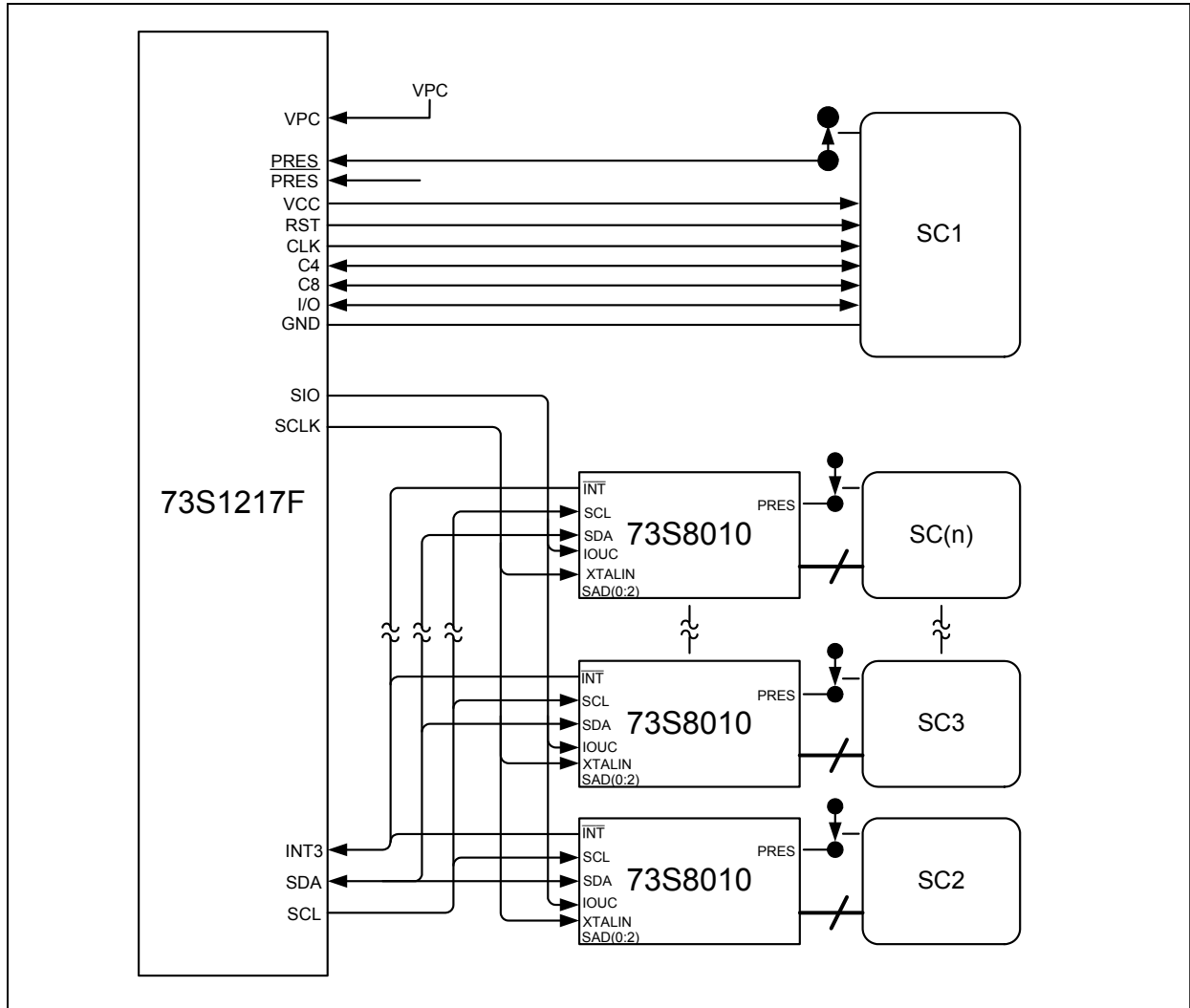

Figure 17: Smart Card Interface Block Diagram

1.7.17.1 ISO 7816 UART

An embedded ISO 7816 (hardware) UART is provided to control communications between a smart card and the 73S1217F MPU. The UART can be shared between the one built-in ICC interface and the external ICC interface. Selection of the desired interface is made via the [SCSel](#) register. Control of the external interface is handled by the I²C interface for any external 73S8010x devices. The following is a list of features for the ISO 7816 UART:

- Two-byte FIFO for temporary data storage on both TX and Rx data.
- Parity checking in T=0. This feature can be enabled/disabled by firmware. Parity error reporting to firmware and Break generation to ICC can be controlled independently.
- Parity error generation for test purposes.
- Retransmission of last byte if ICC indicates T=0 parity error. This feature can be enabled/disabled by firmware.
- Deletion of last byte received if ICC indicates T=0 parity error. This feature can be enabled/disabled by firmware.
- CRC/LRC generation and checking. CRC/LRC is automatically inserted into T=1 data stream by the hardware. This feature can be enabled/disabled by firmware.
- Support baud rates: 230000, 115200, 57600, 38400, 28800, 19200, 14400, 9600 under firmware control (assuming 12MHz crystal) with various F/D settings.
- Firmware manages F/D. All F/D combinations are supported in which F/D is directly divisible by 31 or 32 (i.e. F/D is a multiple of either 31 or 32).
- Flexible ETU clock generation and control.
- Detection of convention (direct or indirect) character TS. This affects both polarity and order of bits in byte. Convention can be overridden by firmware.
- Supports WTX Timeout with an expanded Wait Time Counter (28 bits).
- A Bypass Mode is provided to bypass the hardware UART in order for the software to emulate the UART (for non-standard operating modes). In such a case, the I/O line value is reflected in SFR [SCCti](#) or [SCEcti](#) respectively for the built-in or external interfaces. This mode is appropriate for some synchronous and non T=0 / T=1 cards.

The single integrated smart card UART is capable of supporting T=0 and T=1 cards in hardware, therefore offloading the bit manipulation tasks from the firmware. The embedded firmware instructs the hardware which smart card it should communicate with at any point in time. Firmware reconfigures the UART as required when switching between smart cards. When the 73S1217F has transmitted a message with an expected response, the firmware should not switch the UART to another smart card until the first smart card has responded. If the smart card responds while another smart card is selected, that first smart card's response will be ignored.

1.7.17.2 Answer to Reset Processing

A card insertion event generates an interrupt to the firmware, which is then responsible for the configuration of the electrical interface, the UART and activation of the card. The activation sequencer goes through the power up sequence as defined in the ISO 7816-3 specification. An asynchronous activation timing diagram is shown in Figure 18. After the card RST is de-asserted, the firmware instructs the hardware to look for a TS byte that begins the ATR response. If a response is not provided within the pre-programmed timeout period, an interrupt is generated and the firmware can then take appropriate action, including instructing the 73S1217F to begin a deactivation sequence. Once commanded, the deactivation sequencer goes through the power down sequence as defined in the ISO 7816-3 specification. If an ATR response is received, the hardware looks for a TS byte that determines direct/inverse convention. The hardware handles the indirect convention conversion such that the embedded firmware only receives direct convention. This feature can be disabled by firmware within the [SByteCtl](#) register. Parity checking and break generation is performed on the TS byte unless disabled by firmware. If during the card session, a card removal, over-current or other error event is detected, the hardware will automatically perform the deactivation sequence and then generate an interrupt to the firmware. The firmware can then perform any other error handling required for proper system operation. Smart card RST, I/O and CLK, C4, C8 shall be low before the end of the deactivation sequence. Figure 19 shows the timing for a deactivation sequence.

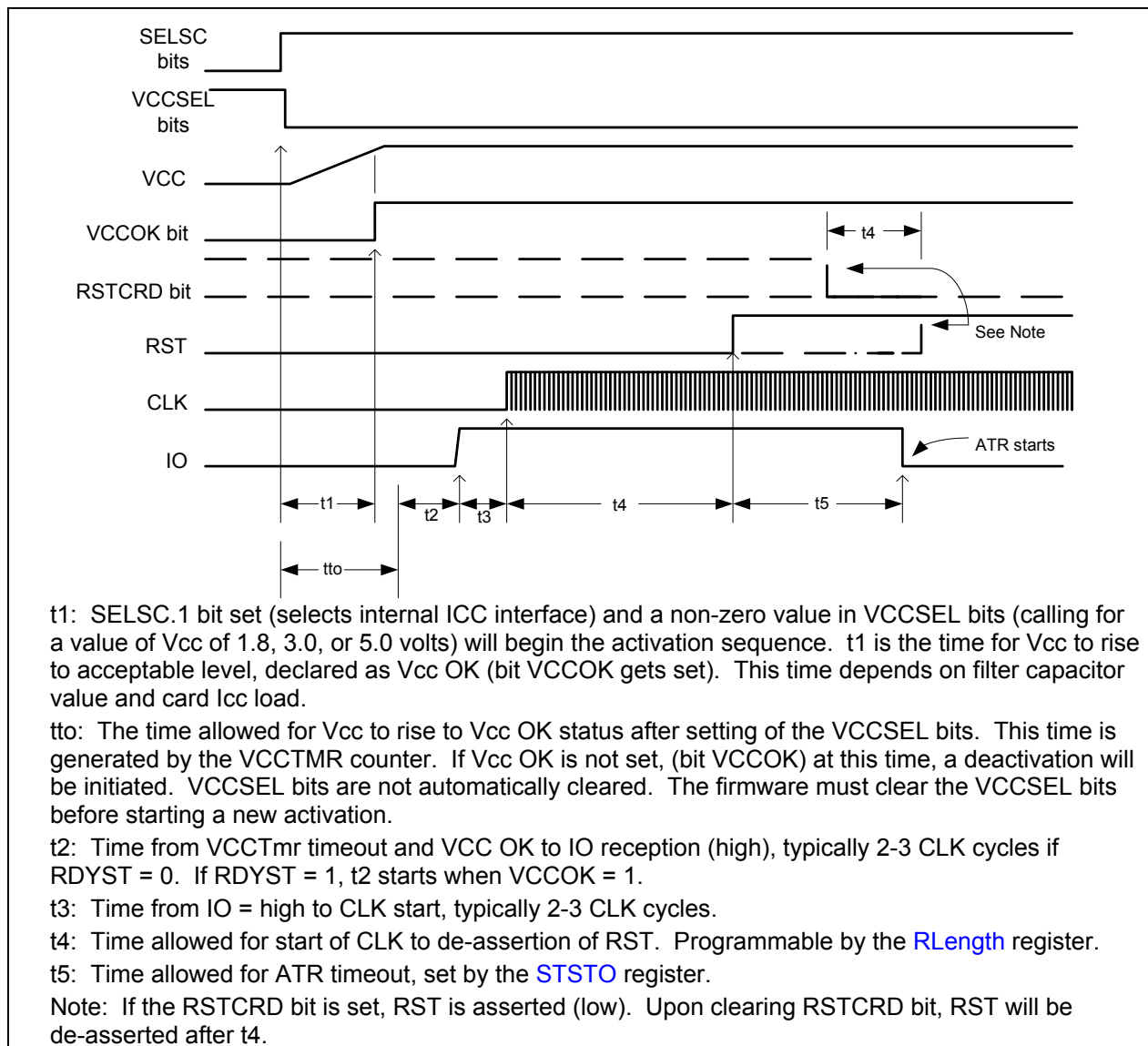

Figure 18: Asynchronous Activation Sequence Timing

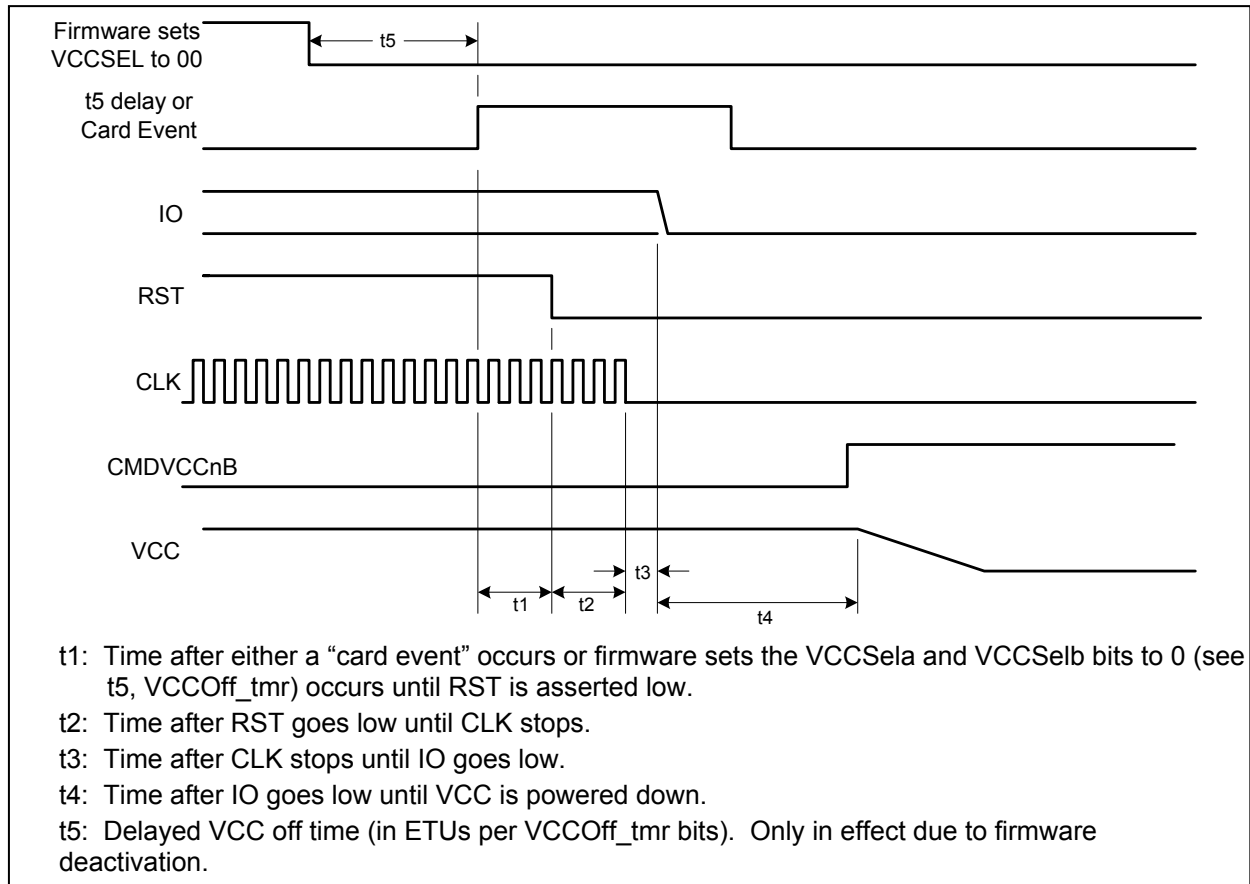

Figure 19: Deactivation Sequence

1.7.17.3 Data Reception/Transmission

When a 12Mhz crystal is used, the smart card UART will generate a 3.69Mhz (default) clock to both smart card interfaces. This will allow approximately 9600bps (1/ETU) communication during ATR (ISO 7816 default). As part of the PPS negotiation between the smart card and the reader, the firmware may determine that the smart card parameters F and D may be changed. After this negotiation, the firmware may change the ETU by writing to the SFR [FDRReg](#) to adjust the ETU and CLK. The firmware may also change the smart card clock frequency by writing to the SFR [SCCLK](#) ([SCECLK](#) for external interface). Independent clock frequency control is provided to each smart card interface. Clock stop high or Clock stop low is supported in asynchronous mode. [Figure 20](#) shows the ETU and CLK control circuits. The firmware determines when clock stop is supported by the smart card and when it is appropriate to go into that mode (and when to come out of it). The smart card UART is clocked by the same clock is provided to the selected smart card. The transition between smart card clocks is handled in hardware to eliminate any glitches for the UART during switchover. The external smart card clock is not affected when switching the UART to communicate with the internal smart card.

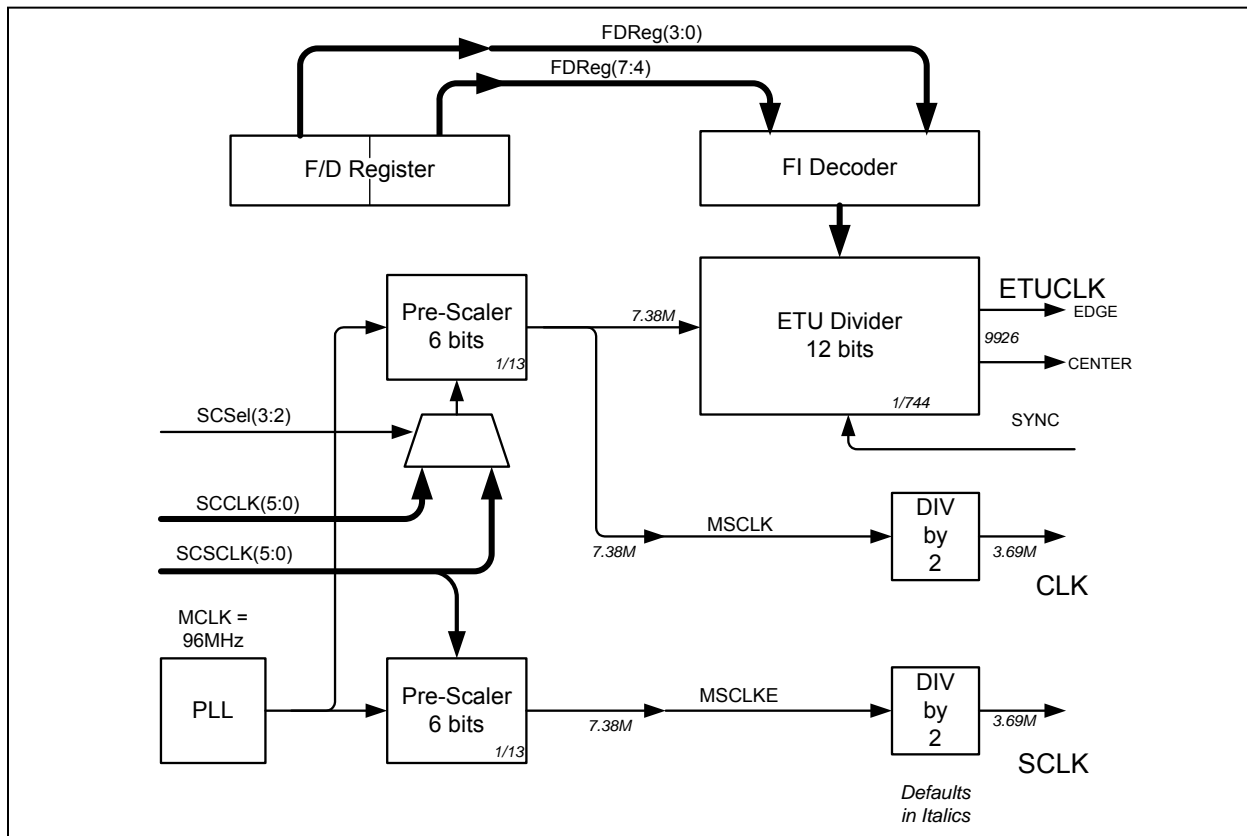

Figure 20: Smart Card CLK and ETU Generation

There are two, two-byte FIFOs that are used to buffer transmit and receive data. During a T=0 processing, if a parity error is detected by the 73S1217F during message reception, an error signal (BREAK) will be generated to the smart card. The byte received will be discarded and the firmware notified of the error. Break generation and receive byte dropping can be disabled under firmware control. During the transmission of a byte, if an error signal (BREAK) is detected, the last byte is retransmitted again and the firmware notified. Retransmission can be disabled by firmware. When a correct byte is received, an interrupt is generated to the firmware, which then reads the byte from the receive FIFO. Receive overruns are detected by the hardware and reported via an interrupt. During transmission of a message, the firmware will write bytes into the transmit FIFO. The hardware will send them to the smart card. When the last byte of a message has been written, the firmware will need to set the LASTTX bit in the [STXCtl](#) SFR. This will cause the hardware to insert the CRC/LRC if in a T=1 protocol mode. CRC/LRC generation/checking is only provided during T=1 processing. Firmware will need to instruct the smart function to go into receive mode after this last transmit data byte if it expects a response from the smart card. At the end of the smart card response, the firmware will put the interface back into transmit mode if appropriate.

The hardware can check for the following card-related timeouts:

- Character Waiting Time (CWT).
- Block Waiting Time (BWT).
- Initial Waiting Time (IWT).

The firmware will load the Wait Time registers with the appropriate value for the operating mode at the appropriate time. [Figure 21](#) shows the guard, block, wait and ATR time definitions. If a timeout occurs, an interrupt will be generated and the firmware can take appropriate recovery steps. Support is provided for adding additional guard times between characters using the [Extra Guard Time register \(EGT\)](#) and between the last byte received by the 73S1217F and the first byte transmitted by the 73S1217F using the [Block Guard Time register \(BGT\)](#). Other than the protocol checks described above, the firmware is responsible for all protocol checking and error recovery.

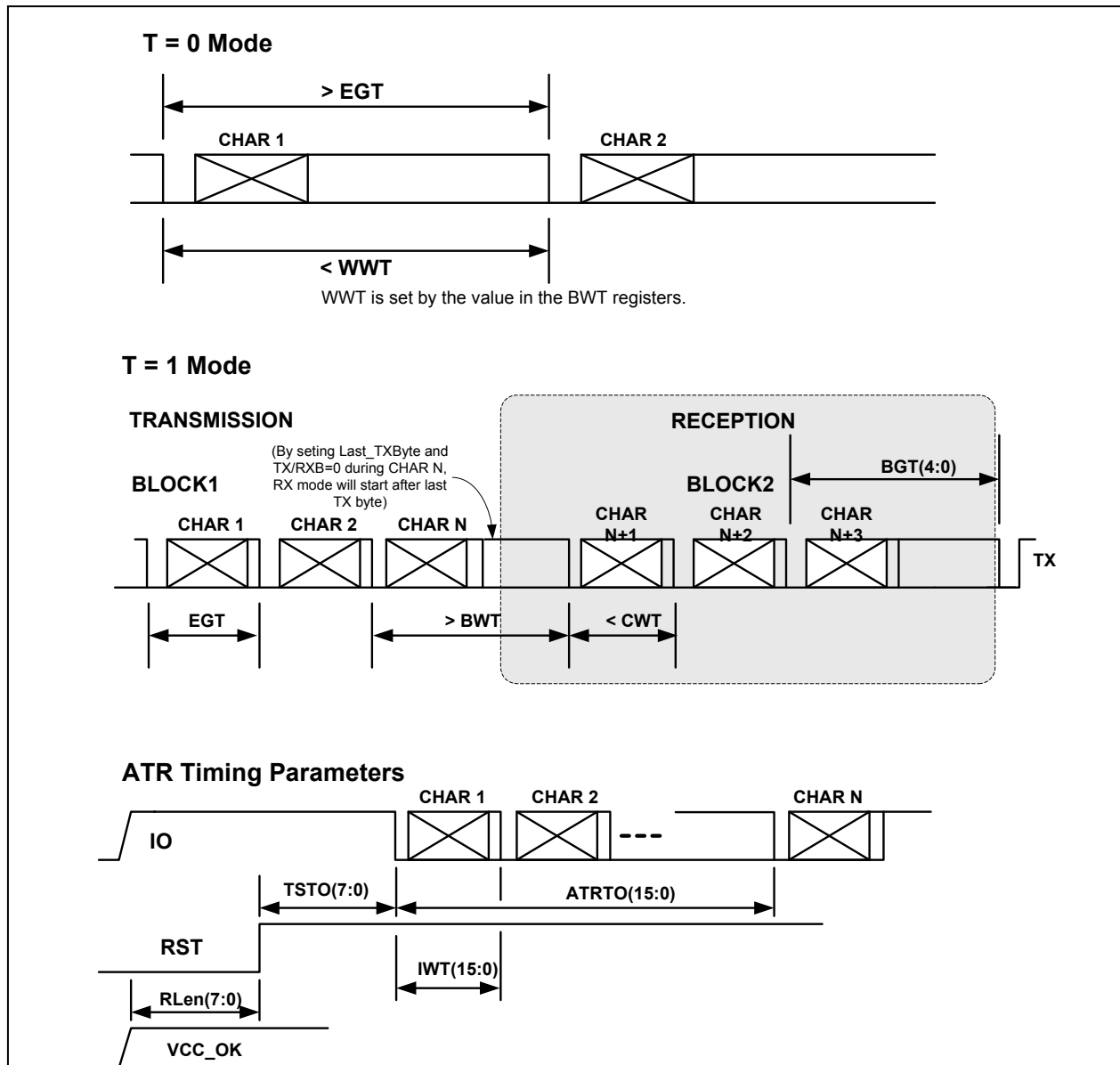

Figure 21: Guard, Block, Wait and ATR Time Definitions

1.7.17.4 Bypass Mode

It is possible to bypass the smart card UART in order for the firmware to support non-T=0/T=1 smart cards. This is called Bypass mode. In this mode the embedded firmware will communicate directly with the selected smart card and drive I/O during transmit and read I/O during receive in order to communicate with the smart card. In this mode, ATR processing is under firmware control. The firmware must sequence the interface signals as required. Firmware must perform TS processing, parity checking, break generation and CRC/LRC calculation (if required).

1.7.17.5 Synchronous Operation Mode

The 73S1217F supports synchronous operation. When sync mode is selected for either interface, the CLK signal is generated by the ETU counter. The values in [FDRReg](#), [SCCLK](#), and [SCECLK](#) must be set to obtain the desired sync CLK rate. There is only one ETU counter and therefore, in sync mode, the interface must be selected to obtain a smart card clock signal. In sync mode, input data is sampled on the rise of CLK, and output data is changed on the fall of CLK.

Special Notes Regarding Synchronous Mode Operation

When the SCISYN or SCESNC bits ([SPrtcol](#), bit 7, bit 5, respectively) are set, the selected smart card interface operates in synchronous mode and there are changes in the definition and behavior of pertinent register bits and associated circuitry. The following requirements are to be noted:

1. The source for the smart card clock (CLK or SCLK) is the ETU counter. Only the actively selected interface can have a running synchronous clock. In contrast, an unselected interface may have a running clock in the asynchronous mode of operation.
2. The control bits CLKLVL, SCLKLVL, CLKOFF, and SCLKOFF are functional in synchronous mode. When the CLKOFF bit is set, it will not truncate either the logic low or logic high period when the (stop at) level is of opposite polarity. The CLK/SCLK signal will complete a correct logic low or logic high duty cycle before stopping at the selected level. The CLK “start” is a result of the falling edge of the CLKOFF bit. Setting clock to run when it is stopped low will result in a half period of low before going high. Setting clock to run when it is stopped high will result in the clock going low immediately and then running at the selected rate with 50% duty cycle (within the limitations of the ETU divisor value).
3. The RLen(7:0) is configured to count the falling edges of the ETU clock (CLK or SCLK) after it has been loaded with a value from 1 to 255. A value of 0 disables the counting function and RLen functions such as I/O source selection (I/O signal bypasses the FIFOs and is controlled by the [SCCLK/SCECLK](#) SFRs). When the RLen counter reaches the “max” (loaded) value, it sets the WAITTO interrupt ([SCInt](#), bit 7), which is maskable via WTOIEN ([SCIE](#), bit 7). I2CMODEIt must be reloaded in order to start the counting/clocking process again. This allows the processor to select the number of CLK cycles and hence, the number of bits to be read or written to/from the card.
4. The FIFO is not clocked by the first CLK (falling) edge resulting from a CLKOFF de-assertion (a clock start event) when the CLK was stopped in the high state and RLen has been loaded but not yet clocked.
5. The state of the pin IO or SIO is sampled on the rising edge of CLK/SCLK and stored in bit 5 of the [SCCtI/SCECtI](#) register.
6. When RLen = max or 0 and I2CMODE = 1 ([STXCtI](#), b7), the IO or SIO signal is directly controlled by the data and direction bits in the respective [SCCtI](#) and [SCECtI](#) register. The state of the data in the TX FIFO is bypassed.
7. In the [SPrtcol](#) register, bit 6 (MODE9/8B) becomes active. When set, the RXData FIFO will read nine-bit words with the state of the ninth bit being readable in [SRXCtI](#), bit 7 (B9DAT). The RXDAV interrupt will occur when the ninth bit has been clocked in (rising edge of CLK or SCLK).
8. Care must be taken to clear the RX and TX FIFOs at the start of any transaction. The user shall read the RX FIFO until it indicates empty status. Reading the TX FIFO twice will reset the input byte pointer and the next write to the TX FIFO will load the byte to the “first out” position. Note that the bit pointer (serializer/deserializer) is reset to bit 0 on any change of the TX/RXD bit.

Special bits that are only active for sync mode include: [SRXCtI](#), b7 “BIT9DAT”, [SPrtcol](#) b6 “MODE9/8B”, [STXCtI](#), b7 “I2CMODE”, and the definition of [SCInt](#) b7, which was “WAITTO”, becomes RLenINT interrupt, and [SCIE](#) b7, which was “WTOIEN”, becomes RLenIEN.

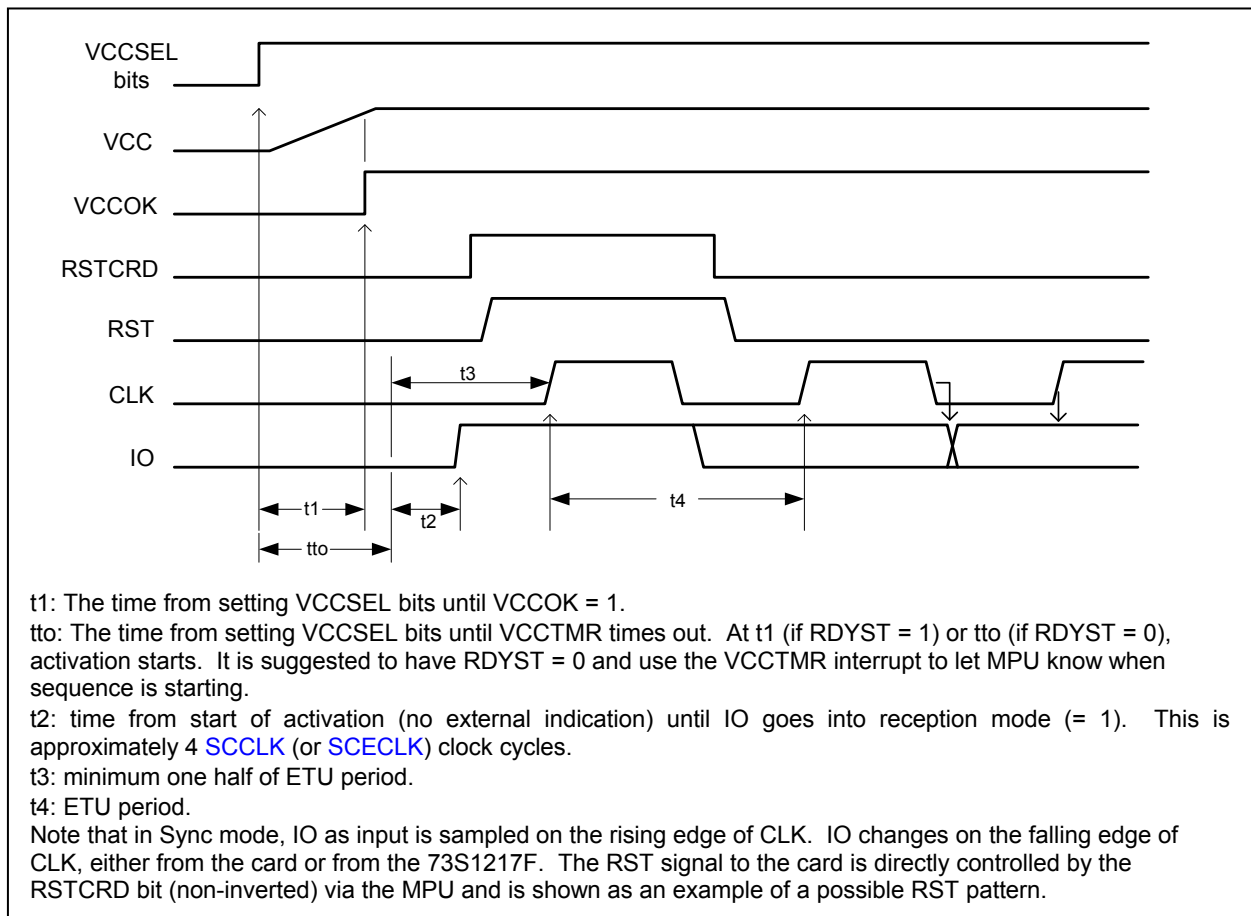

Figure 22: Synchronous Activation

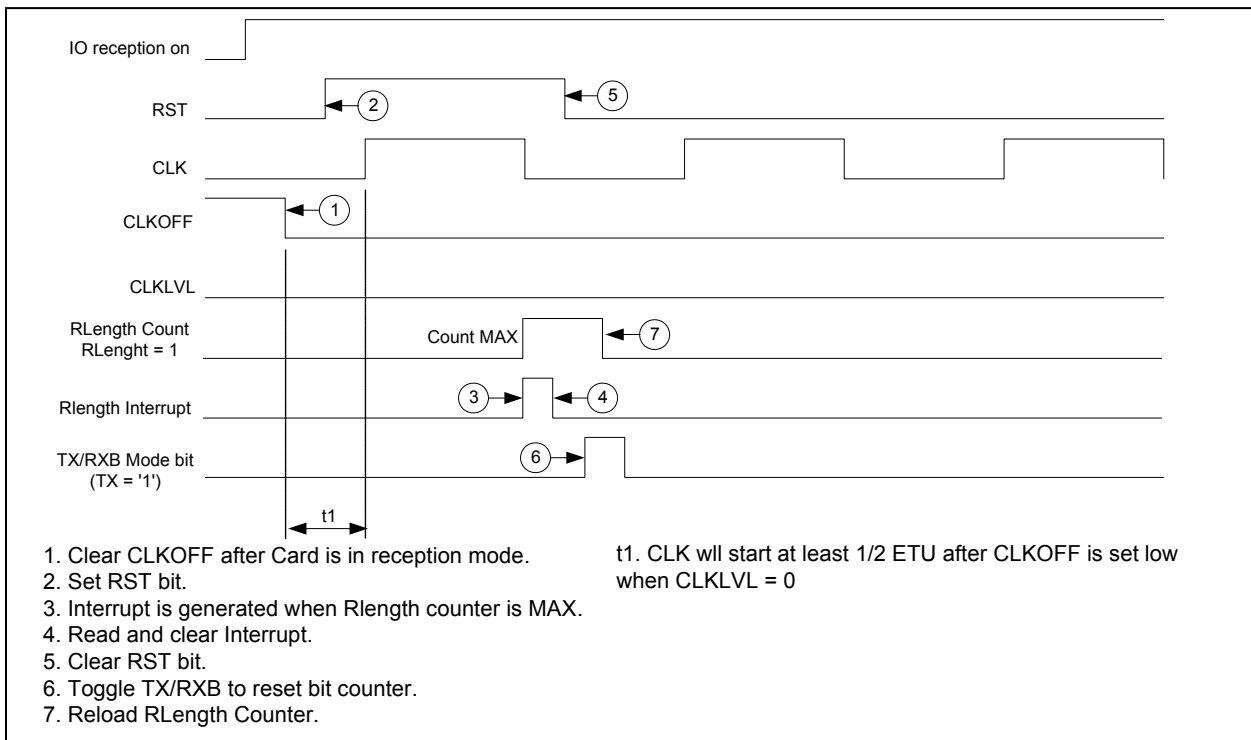

Figure 23: Example of Sync Mode Operation: Generating/Reading ATR Signals

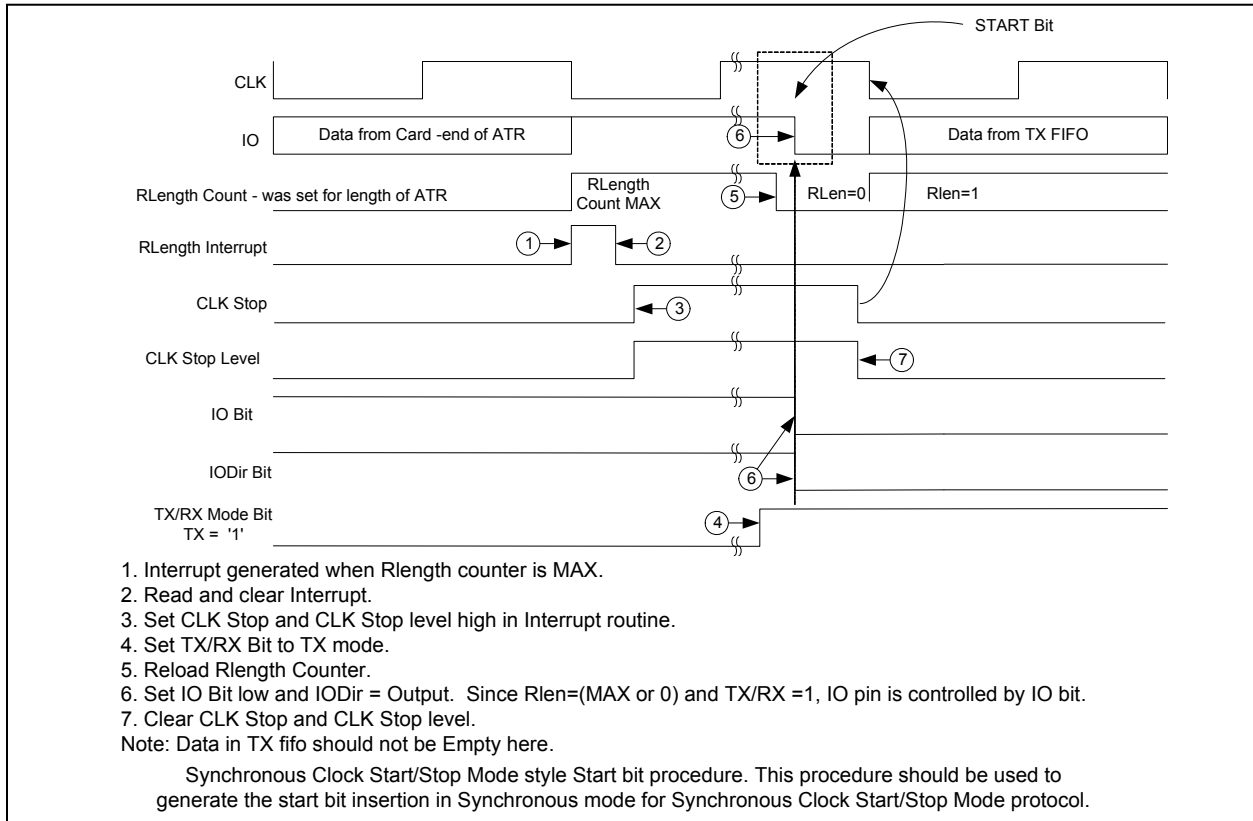

Figure 24: Creation of Synchronous Clock Start/Stop Mode Start Bit in Sync Mode

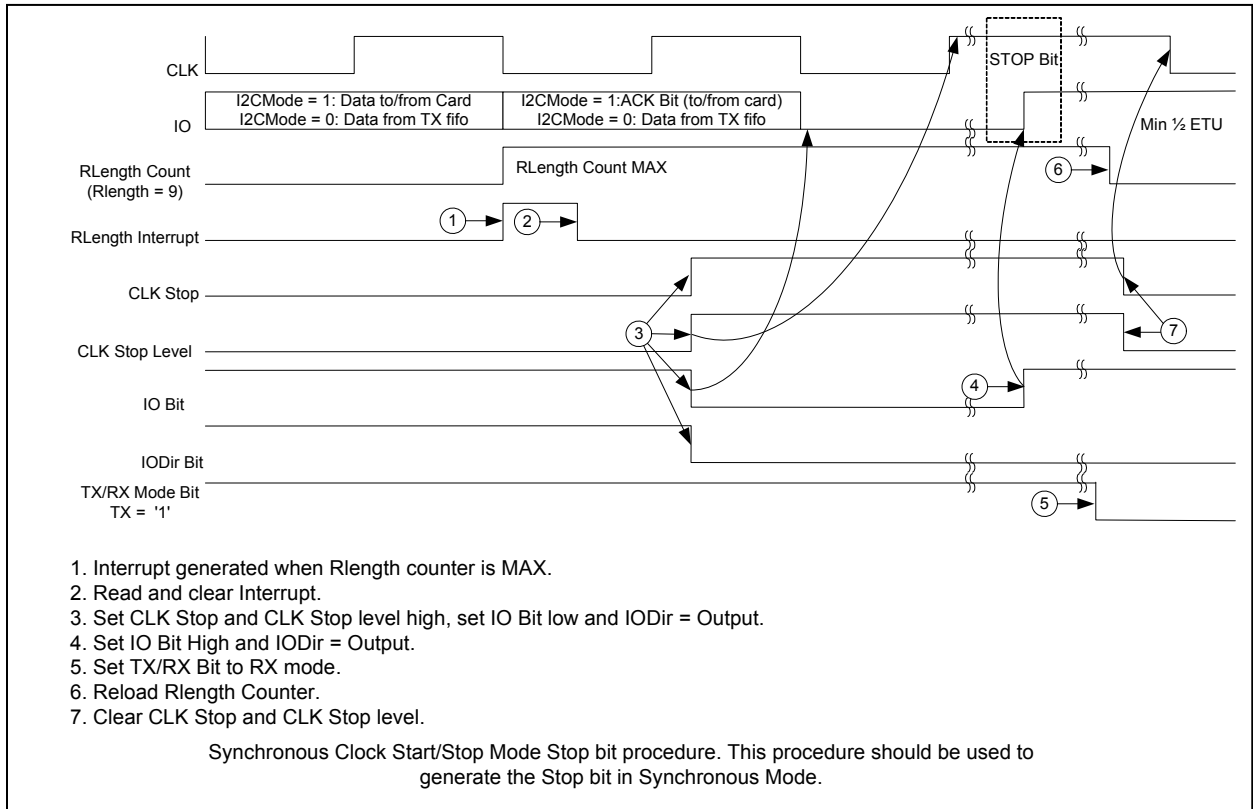

Figure 25: Creation of Synchronous Clock Start/Stop Mode Stop Bit in Sync Mode

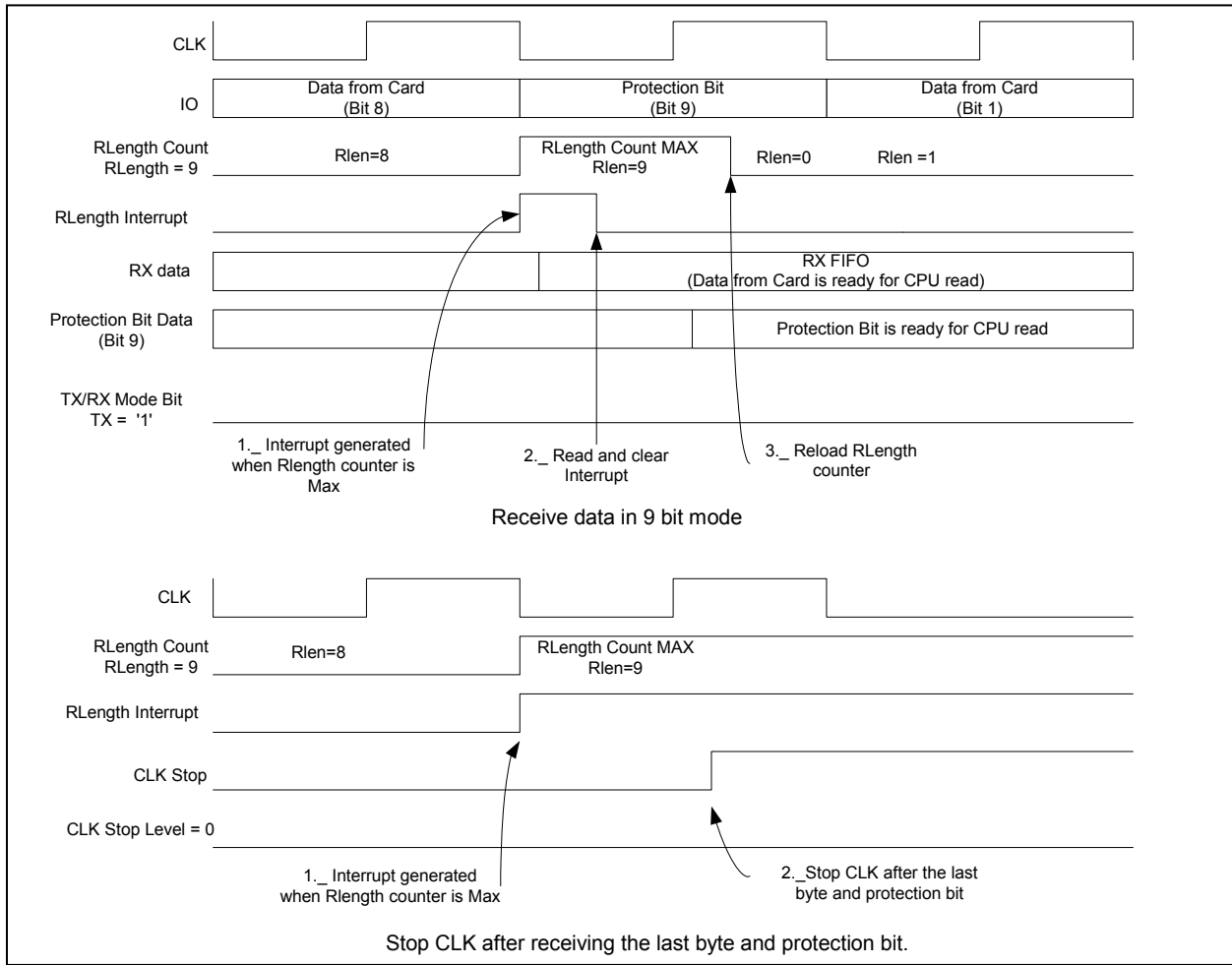

Figure 26: Operation of 9-bit Mode in Sync Mode

Synchronous card operation is broken down into three primary types. These are commonly referred to as 2-wire, 3-wire and I2C synchronous cards. Each card type requires different control and timing and therefore requires different algorithms to access. Teridian has created an application note to provide detailed algorithms for each card type. Refer to the application note titled "73S12xxF Synchronous Card Design Application Note".

1.7.17.6 Smart Card SFRs

Smart Card Select Register (SCSel): 0xFE00 ← 0x00

The Smart Card Select register is used to determine which smart card interface is using the ISO UART. The internal Smart Card has integrated 7816-3 compliant sequencer circuitry to drive an external smart card interface. The external smart card interface relies on 73S8010x parts to generate the ISO 7816-3 compatible signals and sequences. Multiple 73S8010x devices can be connected to the external smart card interface.

Table 79: The SCSel Register

| MSB | | | | | | LSB | | |
|---------|---------|---|---|---|---------|---------|--------|---|
| | – | – | – | – | SELSC.1 | SELSC.0 | BYPASS | – |
| Bit | Symbol | Function | | | | | | |
| SCSel.7 | – | | | | | | | |
| SCSel.6 | – | | | | | | | |
| SCSel.5 | – | | | | | | | |
| SCSel.4 | – | | | | | | | |
| SCSel.3 | SELSC.1 | Select Smart Card Interface – These bits select the interface that is using the ISO UART. These bits do not activate the interface. Activation is performed by the VccCtl register. | | | | | | |
| SCSel.2 | SELSC.0 | 00 = No smart card interface selected. 01 01 = External Smart Card Interface selected (using SCLK, SIO). 02 1X = Internal Smart Card Interface selected. | | | | | | |
| SCSel.1 | BYPASS | 1 = Enabled, 0 = Disabled. When enabled, ISO UART is bypassed and the I/O line is controlled via the SCCtl and SCECtl registers. | | | | | | |
| SCSel.0 | – | | | | | | | |

Smart Card Interrupt Register (SCInt): 0xFE01 ← 0x00

When the smart card interrupt is asserted, the firmware can read this register to determine the actual cause of the interrupt. The bits are cleared when this register is read. Each interrupt can be disabled by the Smart Card Interrupt Enable register. Error processing must be handled by the firmware. This register relates to the interface that is active – see the [SCSel register](#) (above).

Table 80: The SCInt Register

| MSB | | | | LSB | | | |
|---------|---------|---|-------|-------|--------|-------|-------|
| WAITTO | CRDEVT | VCCTMRI | RXDAV | TXEVT | TXSENT | TXERR | RXERR |
| Bit | Symbol | Function | | | | | |
| SCInt.7 | WAITTO | Wait Timeout – An ATR or card wait timeout has occurred. In sync mode, this interrupt is asserted when the RLen counter (it advances on falling edges of CLK/ETU) reaches the loaded (max) value. This bit is cleared when the SCINT register is read. When running in Synchronous Clock Stop Mode, this bit becomes RLenINT interrupt (set when the RLen counter reaches the terminal count). | | | | | |
| SCInt.6 | CRDEVT | Card Event – A card event is signaled via pin DETCARD either when the Card was inserted or removed (read the CRDCtl register to determine card presence) or there was a fault condition in the interface circuitry. This bit is functional even if the smart card logic clock is disabled and when the PWRDN bit is set. This bit is cleared when the SCInt register is read. | | | | | |
| SCInt.5 | VCCTMRI | VCC Timer – This bit is set when the VCCTMR times out. This bit is cleared when the SCInt register is read. | | | | | |
| SCInt.4 | RXDAV | Rx Data Available – Data was received from the smart card because the Rx FIFO is not empty. In bypass mode, this interrupt is generated on a falling edge of the smart card I/O line. After receiving this interrupt in bypass mode, firmware should disable it until the firmware has received the entire byte and is waiting for the next start delimiter. This bit is cleared when there is no RX data available in the RX FIFO. | | | | | |
| SCInt.3 | TXEVT | TX Event – Set whenever the TXEMPTY or TXFULL bits are set in the SRXCtl SFR. This bit is cleared when the STXCtl register is read. | | | | | |
| SCInt.2 | TXSENT | TX Sent – Set whenever the ISO UART has successfully transmitted a byte to the smart card. Also set when a CRC/LRC byte is sent in T=1 mode. Will not be set in T=0 when a break is detected at the end of a byte (when break detection is enabled). This bit is cleared when the SCInt register is read. | | | | | |
| SCInt.1 | TXERR | TX Error – An error was detected during the transmission of data to the smart card as indicated by either BREAKD or TXUNDR bit being set in the STXCtl SFR. Additional information can be found in that register description. This bit is cleared when the STXCtl register is read. | | | | | |
| SCInt.0 | RXERR | RX Error – An error was detected during the reception of data from the smart card. Additional information can be found in the SRXCtl register. This interrupt will be asserted for RXOVERR, or RX Parity error events. This bit is cleared when the SRXCtl register is read. | | | | | |

Smart Card Interrupt Enable Register (SCIE): 0xFE02 ← 0x00

When set to 1, the respective condition can cause a smart card interrupt. When set to a 0, the respective condition cannot cause an interrupt. When disabled, the respective bit in the Smart Card Interrupt register can still be set, but it will not interrupt the MPU.

Table 81: The SCIE Register

| MSB | | | | | | | | LSB |
|--------|---------|---|--------|--------|---------|--------|--------|-----|
| WTOIEN | CDEVEN | VTMREN | RXDAEN | TXEVEN | TXSNTEN | TXEREN | RXEREN | |
| Bit | Symbol | Function | | | | | | |
| SCIE.7 | WTOIEN | Wait Timeout Interrupt Enable – Enable for ATR or Wait Timeout Interrupt. In sync mode, function is RLIEN (RLen = max.) interrupt enable. | | | | | | |
| SCIE.6 | CDEVEN | Card Event Interrupt Enable. | | | | | | |
| SCIE.5 | VTMREN | VCC Timer Interrupt Enable. | | | | | | |
| SCIE.4 | RXDAEN | Rx Data Available Interrupt Enable. | | | | | | |
| SCIE.3 | TXEVEN | TX Event Interrupt Enable. | | | | | | |
| SCIE.2 | TXSNTEN | TX Sent Interrupt Enable. | | | | | | |
| SCIE.1 | TXEREN | TX Error Interrupt Enable. | | | | | | |
| SCIE.0 | RXEREN | RX Error Interrupt Enable. | | | | | | |

Smart Card V_{CC} Control/Status Register (VccCtl): 0xFE03 ← 0x00

This register is used to control the power up and power down of the integrated smart card interface. It is used to determine whether to apply 5V, 3V, or 1.8V to the smart card. Perform the voltage selection with one write operation, setting both VCCSEL.1 and VCCSEL.0 bits simultaneously. The VDDFLT bit (if enabled) will provide an emergency deactivation of the internal smart card slot. See the [VDD Fault Detect Function](#) section for more detail.

Table 82: The VccCtl Register

| | | | | | | | |
|----------|----------|--------|-------|-------|---|---|---------|
| MSB | LSB | | | | | | |
| VCCSEL.1 | VCCSEL.0 | VDDFLT | RDYST | VCCOK | – | – | SCPWRDN |

| Bit | Symbol | Function | | | | | | | | | | | | | | | | | | | | |
|----------|----------|--|-------|----------|----------|-----|---|---|---|----|---|---|---|------|---|---|---|------|---|---|---|----|
| VccCtl.7 | VCCSEL.1 | Setting non-zero value for bits 7,6 will begin activation sequence with target V _{cc} as given below: <table border="1"> <tr> <td>State</td> <td>VCCSEL.1</td> <td>VCCSEL.0</td> <td>VCC</td> </tr> <tr> <td>1</td> <td>0</td> <td>0</td> <td>0V</td> </tr> <tr> <td>2</td> <td>0</td> <td>1</td> <td>1.8V</td> </tr> <tr> <td>3</td> <td>1</td> <td>0</td> <td>3.0V</td> </tr> <tr> <td>4</td> <td>1</td> <td>1</td> <td>5V</td> </tr> </table> | State | VCCSEL.1 | VCCSEL.0 | VCC | 1 | 0 | 0 | 0V | 2 | 0 | 1 | 1.8V | 3 | 1 | 0 | 3.0V | 4 | 1 | 1 | 5V |
| State | VCCSEL.1 | VCCSEL.0 | VCC | | | | | | | | | | | | | | | | | | | |
| 1 | 0 | 0 | 0V | | | | | | | | | | | | | | | | | | | |
| 2 | 0 | 1 | 1.8V | | | | | | | | | | | | | | | | | | | |
| 3 | 1 | 0 | 3.0V | | | | | | | | | | | | | | | | | | | |
| 4 | 1 | 1 | 5V | | | | | | | | | | | | | | | | | | | |
| VccCtl.6 | VCCSEL.0 | A card event or VCCOK going low will initiate a deactivation sequence. When the deactivation sequence for RST, CLK and I/O is complete, V _{CC} will be turned off. When this type of deactivation occurs, the bits must be reset before initiating another activation. | | | | | | | | | | | | | | | | | | | | |
| VccCtl.5 | VDDFLT | If this bit is set = 0, the CMDVCC3B and CMDVCC5B outputs are immediately set = 1 to signal to the companion circuit to begin deactivation when there is a VDD Fault event. If this bit is set = 1 and there is a VDD Fault, the firmware should perform a deactivation sequence and then set CMDVCC3B or CMDVCC5B = 1 to signal the companion circuit to set VCC = 0. | | | | | | | | | | | | | | | | | | | | |
| VccCtl.4 | RDYST | If this bit is set = 1, the activation sequence will start when bit VCCOK is set = 1. If not set, the deactivation sequence shall start when the VCCTMR times out. | | | | | | | | | | | | | | | | | | | | |
| VccCtl.3 | VCCOK | (Read only). Indicates that V _{CC} output voltage is stable. | | | | | | | | | | | | | | | | | | | | |
| VccCtl.2 | – | | | | | | | | | | | | | | | | | | | | | |
| VccCtl.1 | – | | | | | | | | | | | | | | | | | | | | | |
| VccCtl.0 | SCPWRDN | This bit controls the power-off mode of the 73S1217F circuit. 1 = power off, 0 = normal operation. When in power down mode, V _{DD} = 0V. V _{DD} can only be turned on by pressing the ON/OFF switch or by application of 5V to V _{BUS} . If V _{BUS} power is available and SCPWRDN bit is set, it has no effect until V _{BUS} is removed and V _{DD} will shut off. | | | | | | | | | | | | | | | | | | | | |

V_{CC} Stable Timer Register (VccTmr): 0xFE04 ← 0x0F

A programmable timer is provided to set the time from activation start (setting the VCCSEL.1 and VCCSEL.0 bits to non-zero) to when VCC_OK is evaluated. VCC_OK must be true at the end of this timer's programmed interval (t_{to} in Figure 18) in order for the activation sequence to continue. If VCC_OK is not true at the end of the interval (t_{to}), the Card Event interrupt will be set, and a deactivation sequence shall begin including clearing of the VCCSEL bits.

Table 83: The VccTmr Register

| MSB | | | | LSB | | | |
|----------|----------|--|----------|----------|----------|----------|----------|
| OFFTMR.3 | OFFTMR.2 | OFFTMR.1 | OFFTMR.0 | VCCTMR.3 | VCCTMR.2 | VCCTMR.1 | VCCTMR.0 |
| Bit | Symbol | Function | | | | | |
| VccTmr.7 | OFFTMR.3 | VCC Off Timer – The bits set the delay (in number of ETUs) for deactivation after the VCCSEL.1 and VCC SEL.0 have been set to 0. The time value is a count of the 32768Hz clock and is given by $t_{to} = \text{OFFTMR}(7:4) * 30.5\mu\text{s}$. This delay does not affect emergency deactivations due to VDD Fault or card events. A value of 0000 results in no additional delay. | | | | | |
| VccTmr.6 | OFFTMR.2 | | | | | | |
| VccTmr.5 | OFFTMR.1 | | | | | | |
| VccTmr.4 | OFFTMR.0 | | | | | | |
| VccTmr.3 | VCCTMR.3 | VCC Timer – VCCOK must be true at the time set by the value in these bits in order for the activation sequence to continue. If not, the VCCSEL bits will be cleared. The time value is a count of the 32768Hz clock and is given by $t_{to} = \text{VCCTMR}(3:0) * 30.5\mu\text{s}$. A value of 0000 results in no timeout, not zero time, and activation requires that RDYST is set and RDY goes high. | | | | | |
| VccTmr.2 | VCCTMR.2 | | | | | | |
| VccTmr.1 | VCCTMR.1 | | | | | | |
| VccTmr.0 | VCCTMR.0 | | | | | | |

Card Status/Control Register (CRDCtl): 0xFE05 ← 0x00

This register is used to configure the card detect pin (DETCARD) and monitor card detect status. This register must be written to properly configure Debounce, Detect_Polarity (= 0 or = 1), and the pull-up/down enable before setting CDETEN. The card detect logic is functional even without smart card logic clock. When the PWRDN bit is set = 1, no debounce is provided but card presence is operable.

Table 84: The CRDCtl Register

| | | | | | | | | | |
|-----|--------|--------|---|---|--------|-------|------|--------|-----|
| MSB | DEBOUN | CDETEN | – | – | DETPOL | PUENB | PDEN | CARDIN | LSB |
|-----|--------|--------|---|---|--------|-------|------|--------|-----|

| Bit | Symbol | Function |
|----------|--------|--|
| CRDCtl.7 | DEBOUN | Debounce – When set = 1, this will enable hardware de-bounce of the card detect pin. The de-bounce function shall wait for 64ms of stable card detect assertion before setting the CARDIN bit. This counter/timer uses the keypad clock as a source of 1kHz signal. De-assertion of the CARDIN bit is immediate upon de-assertion of the card detect pin(s). |
| CRDCtl.6 | CDETEN | Card Detect Enable – When set = 1, activates card detection input. Default upon power-on reset is 0. |
| CRDCtl.5 | – | |
| CRDCtl.4 | – | |
| CRDCtl.3 | DETPOL | Detect Polarity – When set = 1, the DETCARD pin shall interpret a logic 1 as card present. |
| CRDCtl.2 | PUENB | Enable pull-up current on DETCARD pin (active low). |
| CRDCtl.1 | PDEN | Enable pull-down current on DETCARD pin. |
| CRDCtl.0 | CARDIN | Card Inserted – (Read only). 1 = card inserted, 0 = card not inserted. A change in the value of this bit is a “card event.” A read of this bit indicates whether smart card is inserted or not inserted in conjunction with the DETPOL setting. |

TX Control/Status Register (STXCtl): 0xFE06 ← 0x00

This register is used to control transmission of data to the smart card. Some control and some status bits are in this register.

Table 85: The STXCtl Register

| MSB | | | | | | | | LSB |
|----------|---------|--|---------|--------|--------|--------|--------|-----|
| I2CMODE | – | TXFULL | TXEMPTY | TXUNDR | LASTTX | TX/RXB | BREAKD | |
| Bit | Symbol | Function | | | | | | |
| STXCtl.7 | I2CMODE | I2C Mode – When in sync mode and this bit is set, and when the RLen count value = max or 0, the source of the smart card data for IO pin (or SIO pin) will be connected to the IO bit in SCCtl (or SCECtl) register rather than the TX FIFO. See the description for the Protocol Mode Register for more detail. | | | | | | |
| STXCtl.6 | – | | | | | | | |
| STXCtl.5 | TXFULL | TX FIFO is full. Additional writes may corrupt the contents of the FIFO. This bit it will remain set as long as the TX FIFO is full. Generates a TX_Event interrupt upon going full. | | | | | | |
| STXCtl.4 | TXEMPTY | 1 = TX FIFO is empty, 0 = TX FIFO is not empty. If there is data in the TX FIFO, the circuit will transmit it to the smart card if in transmit mode. In T=1 mode, if the LASTTX bit is set and the hardware is configured to transmit the CRC/LRC, the TXEMPTY will not be set until the CRC/LRC is transmitted. In T=0, if the LASTTX bit is set, TXEMPTY will be set after the last word has been successfully transmitted to the smart card. Generates a TXEVNT interrupt upon going empty. | | | | | | |
| STXCtl.3 | TXUNDR | TX Underrun – (Read only) Asserted when a transmit under-run condition has occurred. An under-run condition is defined as an empty TX FIFO when the last data word has been successfully transmitted to the smart card and the LASTTX bit was not set. No special processing is performed by the hardware if this condition occurs. Cleared when read by firmware. This bit generates a TXERR interrupt. | | | | | | |
| STXCtl.2 | LASTTX | Last TX Byte – Set by firmware (in both T=0 and T=1) when the last byte in the current message has been written into the transmit FIFO. In T=1 mode, the CRC/LRC will be appended to the message. Should be set after the last byte has been written into the transmit FIFO. Should be cleared by firmware before writing first byte of next message into the transmit FIFO. Used in T=0 to determine when to set TXEMPTY. | | | | | | |
| STXCtl.1 | TX/RXB | 1 = Transmit mode, 0 = Receive mode. Configures the hardware to be receiving from or transmitting to the smart card. Determines which counters should be enabled. This bit should be set to receive mode prior to switching to another interface. Setting and resetting this bit shall initialize the CRC logic. If LASTTX is set, this bit can be reset to RX mode and UART logic will automatically change mode to RX when TX operation is completed (TX_Empty =1). | | | | | | |
| STXCtl.0 | BREAKD | Break Detected – (Read only) 1 = A break has been detected on the I/O line indicating that the smart card detected a parity error. Cleared when read. This bit generates a TXERR interrupt. | | | | | | |

STX Data Register (STXData): 0xFE07 ← 0x00**Table 86: The STXData Register**

MSB

LSB

| | | | | | | | |
|----------|----------|----------|----------|----------|----------|----------|----------|
| STXDAT.7 | STXDAT.6 | STXDAT.5 | STXDAT.4 | STXDAT.3 | STXDAT.2 | STXDAT.1 | STXDAT.0 |
|----------|----------|----------|----------|----------|----------|----------|----------|

| Bit | Function |
|-----------|--|
| STXData.7 | Data to be transmitted to smart card. Gets stored in the TX FIFO and then extracted by the hardware and sent to the selected smart card. When the MPU reads this register, the byte pointer is changed to effectively “read out” the data. Thus, two reads will always result in an “empty” FIFO condition. The contents of the FIFO registers are not cleared, but will be overwritten by writes. |
| STXData.6 | |
| STXData.5 | |
| STXData.4 | |
| STXData.3 | |
| STXData.2 | |
| STXData.1 | |
| STXData.0 | |

SRX Control/Status Register (SRXCtl): 0xFE08 ← 0x00

This register is used to monitor reception of data from the smart card.

Table 87: The SRXCtl Register

| MSB | | | | | | | LSB |
|---------|---|--------|--------|--------|---------|------------|---------|
| BIT9DAT | – | LASTRX | CRCERR | RXFULL | RXEMPTY | RXOVR R | PARITYE |

| Bit | Symbol | Function |
|----------|------------|--|
| SRXCtl.7 | BIT9DAT | Bit 9 Data – When in sync mode and with MODE9/8B set, this bit will contain the data on IO (or SIO) pin that was sampled on the ninth CLK (or SCLK) rising edge. This is used to read data in synchronous 9-bit formats. |
| SRXCtl.6 | – | |
| SRXCtl.5 | LASTRX | Last RX Byte – User sets this bit during the reception of the last byte. When byte is received and this bit is set, logic checks CRC to match 0x1D0F (T=1 mode) or LRC to match 00h (T=1 mode), otherwise a CRC or LRC error is asserted. |
| SRXCtl.4 | CRCERR | (Read only) 1 = CRC (or LRC) error has been detected. |
| SRXCtl.3 | RXFULL | (Read only) RX FIFO is full. Status bit to indicate RX FIFO is full. |
| SRXCtl.2 | RXEMPTY | (Read only) RX FIFO is empty. This is only a status bit and does not generate an RX interrupt. |
| SRXCtl.1 | RXOVR R | RX Overrun – (Read Only) Asserted when a receive-over-run condition has occurred. An over-run is defined as a byte was received from the smart card when the RX FIFO was full. Invalid data may be in the receive FIFO. Firmware should take appropriate action. Cleared when read. Additional writes to the RX FIFO are discarded when a RXOVR occurs until the overrun condition is cleared. Will generate an RXERR interrupt. |
| SRXCtl.0 | PARITYE | Parity Error – (Read only) 1 = The logic detected a parity error on incoming data from the smart card. Cleared when read. Will generate RXERR interrupt. |

SRX Data Register (SRXData): 0xFE09 ← 0x00

Table 88: The SRXData Register

MSB

LSB

| | | | | | | | |
|----------|----------|----------|----------|----------|----------|----------|----------|
| SRXDAT.7 | SRXDAT.6 | SRXDAT.5 | SRXDAT.4 | SRXDAT.3 | SRXDAT.2 | SRXDAT.1 | SRXDAT.0 |
|----------|----------|----------|----------|----------|----------|----------|----------|

| Bit | Function |
|-----------|--|
| SRXData.7 | (Read only) Data received from the smart card. Data received from the smart card gets stored in a FIFO that is read by the firmware. |
| SRXData.6 | |
| SRXData.5 | |
| SRXData.4 | |
| SRXData.3 | |
| SRXData.2 | |
| SRXData.1 | |
| SRXData.0 | |

Smart Card Control Register (SCCtl): 0xFE0A ← 0x21

This register is used to monitor reception of data from the smart card.

Table 89: The SCCtl Register

| MSB | | | | LSB | | | |
|---------|--------|---|-----|-----|----|--------|--------|
| RSTCRD | – | IO | IOD | C8 | C4 | CLKLVL | CLKOFF |
| Bit | Symbol | Function | | | | | |
| SCCtl.7 | RSTCRD | 1 = Asserts the RST (set RST = 0) to the smart card interface, 0 = De-assert the RST (set RST = 1) to the smart card interface. Can be used to extend RST to the smart card. Refer to the RLength register description. This bit is operational in all modes and can be used to extend RST during activation or perform a “Warm Reset” as required. In auto-sequence mode, this bit should be set = 0 to allow the sequencer to de-assert RST per the RLength parameters. In sync mode (see the SPrtcol register) the sense of this bit is non-inverted, if set = 1, RST = 1, if set = 0, RST = 0. Rlen has no effect on Reset in sync mode. | | | | | |
| SCCtl.6 | – | | | | | | |
| SCCtl.5 | IO | Smart Card I/O. Read is state of I/O signal (Caution, this signal is not synchronized to the MPU clock). In Bypass mode, write value is state of signal on I/O. In sync mode, this bit will contain the value of I/O pin on the latest rising edge of CLK. | | | | | |
| SCCtl.4 | IOD | Smart Card I/O Direction control Bypass mode or sync mode. 1 = input (default), 0 = output. | | | | | |
| SCCtl.3 | C8 | Smart Card C8. When C8 is an output, the value written to this bit will appear on the C8 line. The value read when C8 is an output is the value stored in the register. When C8 is an input, the value read is the value on the C8 pin (Caution, this signal is not synchronized to the MPU clock). When C8 is an input, the value written will be stored in the register but not presented to the C8 pin. | | | | | |
| SCCtl.2 | C4 | Smart Card C4. When C4 is an output, the value written to this bit will appear on the C4 line. The value read when C4 is an output is the value stored in the register. When C4 is an input, the value read is the value on the C4 pin (Caution, this signal is not synchronized to the MPU clock). When C4 is an input, the value written will be stored in the register but not presented to the C4 pin. | | | | | |
| SCCtl.1 | CLKLVL | 1 = High, 0 = Low. If CLKOFF is set = 1, the CLK to smart card will be at the logic level indicated by this bit. If in bypass mode, this bit directly controls the state of CLK. | | | | | |
| SCCtl.0 | CLKOFF | 0 = CLK is enabled. 1 = CLK is not enabled. When asserted, the CLK will stop at the level selected by CLKLVL. This bit has no effect if in bypass mode. | | | | | |

External Smart Card Control Register (SCECtl): 0xFE0B ← 0x00

This register is used to directly set and sample signals of External Smart Card interface. There are three modes of asynchronous operation, an “automatic sequence” mode, and bypass mode. Clock stop per the ISO 7816-3 interface is also supported but firmware must handle the protocol for SIO and SCLK for I²C clock stop and start. Control for Reset (to make RST signal), activation control, voltage select, etc. should be handled via the I²C interface when using external 73S73S8010x devices. USR(n) pins shall be used for C4, C8 functions if necessary.

Table 90: The SCECtl Register

| MSB | | | | | | | | LSB | |
|-----|---|-----|------|---|---|---------|---------|-----|--|
| – | – | SIO | SIOD | – | – | SCLKLVL | SCLKOFF | | |

| Bit | Symbol | Function |
|----------|---------|--|
| SCECtl.7 | – | |
| SCECtl.6 | – | |
| SCECtl.5 | SIO | External Smart Card I/O. Bit when read indicates state of pin SIO for SIOD = 1 (Caution, this signal is not synchronized to the MPU clock), when written, sets the state of pin SIO for SIOD = 0. Ignored if not in bypass or sync modes. In sync mode, this bit will contain the value of IO pin on the latest rising edge of SCLK. |
| SCECtl.4 | SIOD | 1 = input, 0 = output. External Smart Card I/O Direction control. Ignored if not in bypass or sync modes. |
| SCECtl.3 | – | |
| SCECtl.2 | – | |
| SCECtl.1 | SCLKLVL | Sets the state of SCLK when disabled by SCLKOFF bit. If in bypass mode, this bit directly controls the state of SCLK. |
| SCECtl.0 | SCLKOFF | 0 = SCLK enabled, 1 = SCLK disabled. When disabled, SCLK level is determined by SCLKLVL. This bit has no effect if in bypass mode. |

C4/C8 Data Direction Register (SCDIR): 0xFE0C ← 0x00

This register determines the direction of the internal interface C4/C8 lines. After reset, all signals are tri-stated.

Table 91: The SCDIR Register

| | | | | | | | | |
|-----|---|---|---|---|-----|-----|---|-----|
| MSB | - | - | - | - | C8D | C4D | - | LSB |
|-----|---|---|---|---|-----|-----|---|-----|

| Bit | Symbol | Function |
|---------|--------|---|
| SCDIR.7 | - | |
| SCDIR.6 | - | |
| SCDIR.5 | - | |
| SCDIR.4 | - | |
| SCDIR.3 | C8D | 1 = input, 0 = output. Smart Card C8 direction. |
| SCDIR.2 | C4D | 1 = input, 0 = output. Smart Card C4 direction. |
| SCDIR.1 | - | |
| SCDIR.0 | - | |

Protocol Mode Register (SPrtcol): 0xFE0D ← 0x03

This register determines the protocol to be use when communicating with the selected smart card. This register should be updated as required when switching between smart card interfaces.

Table 92: The SPrtcol Register

| MSB | | | | | | | | LSB |
|-----------|---------|--|---|-------|-------|-------|--------|-----|
| SCISYN | MOD9/8B | SCESYN | 0 | TMODE | CRCEN | CRCMS | RCVATR | |
| Bit | Symbol | Function | | | | | | |
| SPrtcol.7 | SCISYN | Smart Card Internal Synchronous mode – Configures internal smart card interface for synchronous mode. This mode routes the internal interface buffers for RST, IO, C4, C8 to SCCti register bits for direct firmware control. CLK is generated by the ETU counter. | | | | | | |
| SPrtcol.6 | MOD9/8B | Synchronous 8/9 bit mode select – For sync mode, in protocols with 9-bit words, set this bit. The first eight bits read go into the RX FIFO and the ninth bit read will be stored in the IO (or SIO) data bit of the SRXCti register. | | | | | | |
| SPrtcol.5 | SCESYN | Smart Card External Synchronous mode – Configures External Smart Card interface for synchronous mode. This mode routes the external smart card interface buffers for SIO to SCECti register bits for direct firmware control. SCLK is generated by the ETU counter. | | | | | | |
| SPrtcol.4 | 0 | Reserved bit, must always be set to 0. | | | | | | |
| SPrtcol.3 | TMODE | Protocol mode select – 0: T=0, 1: T=1. Determines which smart card protocol is to be used during message processing. | | | | | | |
| SPrtcol.2 | CRCEN | CRC Enable – 1 = Enabled, 0 = Disabled. Enables the checking/generation of CRC/LRC while in T=1 mode. Has no effect in T=0 mode. If enabled and a message is being transmitted to the smart card, the CRC/LRC will be inserted into the message stream after the last TX byte is transmitted to the smart card. If enabled, CRC/LRC will be checked on incoming messages and the value made available to the firmware via the CRC LS/MS registers. | | | | | | |
| SPrtcol.1 | CRCMS | CRC Mode Select – 1 = CRC, 0 = LRC. Determines type of checking algorithm to be used. | | | | | | |
| SPrtcol.0 | RCVATR | Receive ATR – 1 = Enable ATR timeout, 0 = Disable ATR timeout. Set by firmware after the smart card has been turned on and the hardware is expecting ATR. | | | | | | |

SC Clock Configuration Register (SCCLK): 0xFE0F ← 0x0C

This register controls the internal smart card (CLK) clock generation.

Table 93: The SCCLK Register

MSB LSB

| | | | | | | | |
|---|---|----------|----------|----------|----------|----------|----------|
| – | – | ICLKFS.5 | ICLKFS.4 | ICLKFS.3 | ICLKFS.2 | ICLKFS.1 | ICLKFS.0 |
|---|---|----------|----------|----------|----------|----------|----------|

| Bit | Symbol | Function |
|---------|----------|---|
| SCCLK.7 | – | |
| SCCLK.6 | – | |
| SCCLK.5 | ICLKFS.5 | Internal Smart Card CLK Frequency Select – Division factor to determine internal smart card CLK frequency. MCLK clock is divided by (register value + 1) to clock the ETU divider, and then by 2 to generate CLK. Default ratio is 13. The programmed value in this register is applied to the divider after this value is written, in such a manner as to produce a glitch-free output, regardless of the selection of active interface. A register value = 0 will default to the same effect as register value = 1. |
| SCCLK.4 | ICLKFS.4 | |
| SCCLK.3 | ICLKFS.3 | |
| SCCLK.2 | ICLKFS.2 | |
| SCCLK.1 | ICLKFS.1 | |
| SCCLK.0 | ICLKFS.0 | |

External SC Clock Configuration Register (SCECLK): 0xFE10 ← 0x0C

This register controls the external smart card (SCLK) clock generation.

Table 94: The SCECLK Register

MSB

LSB

| | | | | | | | |
|---|---|----------|----------|--------------|----------|----------|----------|
| – | – | ECLKFS.5 | ECLKFS.4 | ECLKFS. 3 | ECLKFS.2 | ECLKFS.1 | ECLKFS.0 |
|---|---|----------|----------|--------------|----------|----------|----------|

| Bit | Symbol | Function |
|----------|----------|--|
| SCECLK.7 | – | |
| SCECLK.6 | – | |
| SCECLK.5 | ECLKFS.5 | External Smart Card CLK Frequency Select – Division factor to determine external smart card CLK frequency. MCLK clock is divided by (register value + 1) to clock the ETU divider, and then by 2 to generate SCLK. Default ratio is 13. The programmed value in this register is applied to the divider after this value is written, in such a manner as to produce a glitch-free output, regardless of the selection of active interface. A register value = 0 will default to the same effect as register value = 1. |
| SCECLK.4 | ECLKFS.4 | |
| SCECLK.3 | ECLKFS.3 | |
| SCECLK.2 | ECLKFS.2 | |
| SCECLK.1 | ECLKFS.1 | |
| SCECLK.0 | ECLKFS.0 | |

Parity Control Register (SParCtl): 0xFE11 ← 0x00

This register provides the ability to configure the parity circuitry on the smart card interface. The settings apply to both integrated smart card interfaces.

Table 95: The SParCtl Register

| MSB | | | | | | | | LSB |
|-----------|--------|---|--------|--------|--------|--------|-------|--------|
| | – | DISPAR | BRKGEN | BRKDET | RETRAN | DISCRX | INSPE | FORCPE |
| Bit | Symbol | Function | | | | | | |
| SParCtl.7 | – | | | | | | | |
| SParCtl.6 | DISPAR | Disable Parity Check – 1 = disabled, 0 = enabled. If enabled, the UART will check for even parity (the number of 1's including the parity bit is even) on every character. This also applies to the TS during ATR. | | | | | | |
| SParCtl.5 | BRKGEN | Break Generation Disable – 1 = disabled, 0 = enabled. If enabled, and T=0 protocol, the UART will generate a Break to the smart card if a parity error is detected on a receive character. No Break will be generated if parity checking is disabled. This also applies to TS during ATR. | | | | | | |
| SParCtl.4 | BRKDET | Break Detection Disable – 1 = disabled, 0 = enabled. If enabled, and T=0 protocol, the UART will detect the generation of a Break by the smart card. | | | | | | |
| SParCtl.3 | RETRAN | Retransmit Byte – 1 = enabled, 0 = disabled. If enabled and a Break is detected from the smart card (Break Detection must be enabled), the last character will be transmitted again. This bit applies to T=0 protocol. | | | | | | |
| SParCtl.2 | DISCRX | Discard Received Byte – 1 = enabled, 0 = disabled. If enabled and a parity error is detected (Parity checking must be enabled), the last character received will be discarded. This bit applies to T=0 protocol. | | | | | | |
| SParCtl.1 | INSPE | Insert Parity Error – 1 = enabled, 0 = disabled. Used for test purposes. If enabled, the UART will insert a parity error in every character transmitted by generating odd parity instead of even parity for the character. | | | | | | |
| SParCtl.0 | FORCPE | Force Parity Error – 1 = enabled, 0 = disabled. Used for test purposes. If enabled, the UART will generate a parity error on a character received from the smart card. | | | | | | |

Byte Control Register (SByteCtl): 0xFE12 ← 0x2C

This register controls the processing of characters and the detection of the TS byte. When receiving, a Break is asserted at 10.5 ETU after the beginning of the start bit. Break from the card is sampled at 11 ETU.

Table 96: The SByteCtl Register

| MSB | | | | | | | LSB |
|-----|-------|-------|----------|--------------|---|---|-----|
| – | DETTS | DIRTS | BRKDUR.1 | BRKDUR. 0 | – | – | – |

| Bit | Symbol | Function |
|------------|----------|---|
| SByteCtl.7 | – | |
| SByteCtl.6 | DETTS | Detect TS Byte – 1 = Next Byte is TS, 0 = Next byte is not TS. When set, the hardware will treat the next character received as the TS and determine if direct or indirect convention is being used. Direct convention is the default used if firmware does not set this bit prior to transmission of TS by the smart card to the firmware. The hardware will check parity and generate a break as defined by the DISPAR and BRKGEN bits in the parity control register. This bit is cleared by hardware after TS is received. TS is decoded before being stored in the receive FIFO. |
| SByteCtl.5 | DIRTS | Direct Mode TS Select – 1 = direct mode, 0 = indirect mode. Set/cleared by hardware when TS is processed indicating either direct/indirect mode of operation. When switching between smart cards, the firmware should write the bit appropriately since this register is not unique to an individual smart card (firmware should keep track of this bit). |
| SByteCtl.4 | BRKDUR.1 | Break Duration Select – 00 = 1 ETU, 01 = 1.5 ETU, 10 = 2 ETU, 11 = reserved. Determines the length of a Break signal which is generated when detecting a parity error on a character reception in T=0 mode. |
| SByteCtl.3 | BRKDUR.0 | |
| SByteCtl.2 | – | |
| SByteCtl.1 | – | |
| SByteCtl.0 | – | |

FD Control Register (FReg): 0xFE13 ← 0x11**Table 97: The FReg Register**

| MSB | | | | LSB | | | |
|--------|--------|---|--------|--------|--------|--------|--------|
| FVAL.3 | FVAL.2 | FVAL.1 | FVAL.0 | DVAL.3 | DVAL.2 | DVAL.1 | DVAL.0 |
| Bit | Symbol | Function | | | | | |
| FReg.7 | FVAL.3 | Refer to Table 99. This value is converted per the table to set the divide ratio used to generate the baud rate (ETU). Default, also used for ATR, is 0001 ($F_i = 372$). This value is used by the selected interface. | | | | | |
| FReg.6 | FVAL.2 | | | | | | |
| FReg.5 | FVAL.1 | | | | | | |
| FReg.4 | FVAL.0 | | | | | | |
| FReg.3 | DVAL.3 | Refer to Table 99. This value is used to set the divide ratio used to generate the smart card CLK. Default, also used for ATR, is 0001 ($D_i = 1$). | | | | | |
| FReg.2 | DVAL.2 | | | | | | |
| FReg.1 | DVAL.1 | | | | | | |
| FReg.0 | DVAL.0 | | | | | | |

This register uses the transmission factors F and D to set the ETU (baud) rate. The values in this register are mapped to the ISO 7816 conversion factors as described below. The CLK signal for each interface is created by dividing a high-frequency, intermediate signal (MSCLK) by 2. The ETU baud rate is created by dividing MSCLK by 2 times the F_i/D_i ratio specified by the codes below. For example, if $F_i = 0001$ and $D_i = 0001$, the ratio of F_i/D_i is $372/1$. Thus, the ETU divider is configured to divide by $2 * 372 = 744$. The maximum supported F/D ratio is 4096.

Table 98: Divider Ratios Provided by the ETU Counter

| | | | | | | | | |
|------------|------|------|------|------|------|------|------|---------------|
| Fi (code) | 0000 | 0001 | 0010 | 0011 | 0100 | 0101 | 0110 | 0111 |
| Fi (ratio) | 372 | 372 | 558 | 744 | 1116 | 1488 | 1860 | 1860 \oplus |
| FCLK max | 4 | 5 | 6 | 8 | 12 | 16 | 20 | 20 \oplus |

| | | | | | | | | |
|------------|--------------|------|------|------|------|------|---------------|---------------|
| Fi (code) | 1000 | 1001 | 1010 | 1011 | 1100 | 1101 | 1110 | 1111 |
| Fi (ratio) | 512 \oplus | 512 | 768 | 1024 | 1536 | 2048 | 2048 \oplus | 2048 \oplus |
| FCLK max | 5 \oplus | 5 | 7.5 | 10 | 15 | 20 | 20 \oplus | 20 \oplus |

| | | | | | | | | |
|------------|------------|------|------|------|------|------|------|-------------|
| Di (code) | 0000 | 0001 | 0010 | 0011 | 0100 | 0101 | 0110 | 0111 |
| Di (ratio) | 1 \oplus | 1 | 2 | 4 | 8 | 16 | 32 | 32 \oplus |

| | | | | | | | | |
|------------|------|------|-------------|-------------|-------------|-------------|-------------|-------------|
| Di (code) | 1000 | 1001 | 1010 | 1011 | 1100 | 1101 | 1110 | 1111 |
| Di (ratio) | 12 | 20 | 16 \oplus | 16 \oplus | 16 \oplus | 16 \oplus | 16 \oplus | 16 \oplus |

Note: values marked with \oplus are not included in the ISO definition and arbitrary values have been assigned.

The values given below are used by the ETU divider to create the ETU clock. The entries that are not shaded will result in precise CLK/ETU per ISO requirements. Shaded areas are not precise but are within 1% of the target value.

Table 99: Divider Values for the ETU Clock

| | Fi code | 0000 | 0001 | 0010 | 0011 | 0100 | 0101 |
|---------|----------|------|------|------|------|------|------|
| Di code | F→ D↓ | 372 | 372 | 558 | 744 | 1116 | 1488 |
| 0001 | 1 | 744 | 744 | 1116 | 1488 | 2232 | 2976 |
| 0010 | 2 | 372 | 372 | 558 | 744 | 1116 | 1488 |
| 0011 | 4 | 186 | 186 | 279 | 372 | 558 | 744 |
| 0100 | 8 | 93 | 93 | 138 | 186 | 279 | 372 |
| 1000 | 12 | 62 | 62 | 93 | 124 | 186 | 248 |
| 0101 | 16 | 47 | 47 | 70 | 93 | 140 | 186 |
| 1001 | 20 | 37 | 37 | 56 | 74 | 112 | 149 |
| 0110 | 32 | 23 | 23 | 35 | 47 | 70 | 93 |

| | Fi code | 0110 | 1001 | 1010 | 1011 | 1100 | 1101 |
|---------|----------|------|------|------|------|------|------|
| Di code | F→ D↓ | 1860 | 512 | 768 | 1024 | 1536 | 2048 |
| 0001 | 1 | 3720 | 1024 | 1536 | 2048 | 3072 | 4096 |
| 0010 | 2 | 1860 | 512 | 768 | 1024 | 1536 | 2048 |
| 0011 | 4 | 930 | 256 | 384 | 512 | 768 | 1024 |
| 0100 | 8 | 465 | 128 | 192 | 256 | 384 | 512 |
| 1000 | 12 | 310 | 85 | 128 | 171 | 256 | 341 |
| 0101 | 16 | 233 | 64 | 96 | 128 | 192 | 256 |
| 1001 | 20 | 186 | 51 | 77 | 102 | 154 | 205 |
| 0110 | 32 | 116 | 32 | 48 | 64 | 96 | 128 |

CRC MS Value Registers (CRCMsB): 0xFE14 ← 0xFF, (CRCLsB): 0xFE15 ← 0xFF**Table 100: The CRCMsB Register**

| MSB | | | | | | LSB | |
|--------|--------|--------|--------|--------|--------|-------|-------|
| CRC.15 | CRC.14 | CRC.13 | CRC.12 | CRC.11 | CRC.10 | CRC.9 | CRC.8 |

Table 101: The CRCLsB Register

| MSB | | | | | | LSB | |
|-------|-------|-------|-------|-------|-------|-------|-------|
| CRC.7 | CRC.6 | CRC.5 | CRC.4 | CRC.3 | CRC.2 | CRC.1 | CRC.0 |

The 16-bit CRC value forms the TX CRC word in TX mode (write value) and the RX CRC in RX mode (read value). The initial value of CRC to be used when generating a CRC to be transmitted at the end of a message (after the last TX byte is sent) when enabled in T=1 mode. Should be reloaded at the beginning of every message to be transmitted. When using CRC, both CRC registers should be initialized to FF. When using LRC the CRCLsB Value register should be loaded to 00. When receiving a message, the firmware should load this with the initial value and then read this register to get the final value at the end of the message. These registers need to be reloaded for each new message to be received. When in LRC mode, bits (7:0) are used and bits (15:8) are undefined. During LRC/CRC checking and generation, this register is updated with the current value and can be read to aid in debugging. This information will be transmitted to the smart card using the timing specified by the Guard Time register. When checking CRC/LRC on an incoming message (CRC/LRC is checked against the data and CRC/LRC), the firmware reads the final value after the message has been received and determines if an error occurred (= 0x1D0F (CRC) no error, else error; = 0 (LRC) no error, else error). When a message is received, the CRC/LRC is stored in the FIFO. The polynomial used to generate and check CRC is $x^{16} + x^{12} + x^5 + 1$. When in indirect convention, the CRC is generated prior to the conversion into indirect convention. When in indirect convention, the CRC is checked after the conversion out of indirect convention. For a given message, the CRC generated (and readable from this register) will be the same whether indirect or direct convention is used to transmit the data to the smart card. The CRCLsB / CRCMsB registers will be updated with CRC/LRC whenever bits are being received or transmitted from/to the smart card (even if CRCEN is not set and in mode T1). They are available to the firmware to use if desired.

Block Guard Time Register (BGT): 0xFE16 ← 0x10

This register contains the Extra Guard Time Value (EGT) most-significant bit. The Extra Guard Time indicates the minimum time between the leading edges of the start bit of consecutive characters. The delay depends on the T=0/T=1 mode. Used in transmit mode. This register also contains the Block Guard Time (BGT) value. Block Guard Time is the minimum time between the leading edge of the start bit of the last character received and the leading edge of the start bit of the first character transmitted. This should not be set less than the character length. The transmission of the first character will be held off until BGT has elapsed regardless of the TX data and TX/RX control bit timing.

Table 102: The BGT Register

| MSB | | | | LSB | | | |
|-------|---|---|-------|-------|-------|-------|-------|
| EGT.8 | – | – | BGT.4 | BGT.3 | BGT.1 | BGT.2 | BGT.0 |

| Bit | Symbol | Function |
|-------|--------|---|
| BGT.7 | EGT.8 | Most-significant bit for 9-bit EGT timer. See EGT below. |
| BGT.6 | – | |
| BGT.5 | – | |
| BGT.4 | BGT.4 | Time in ETUs between the start bit of the last received character to start bit of the first character transmitted to the smart card. Default value is 22. |
| BGT.3 | BGT.3 | |
| BGT.2 | BGT.2 | |
| BGT.1 | BGT.1 | |
| BGT.0 | BGT.0 | |

Extra Guard Time Register (EGT): 0xFE17 ← 0x0C

This register contains the Extra Guard Time Value (EGT) least-significant byte. The Extra Guard Time indicates the minimum time between the leading edges of the start bit of consecutive characters. The delay depends on the T=0/T=1 mode. Used in transmit mode.

Table 103: The EGT Register

| MSB | | | | | | LSB | |
|-------|-------|-------|-------|-------|-------|-------|-------|
| EGT.7 | EGT.6 | EGT.5 | EGT.4 | EGT.3 | EGT.1 | EGT.2 | EGT.0 |

| Bit | Function |
|-------|---|
| EGT.7 | Time in ETUs between start bits of consecutive characters. In T=0 mode, the minimum is 1. In T=0, the leading edge of the next start bit may be delayed if there is a break detected from the smart card. Default value is 12. In T=0 mode, regardless of the value loaded, the minimum value is 12, and for T=1 mode, the minimum value is 11. |
| EGT.6 | |
| EGT.5 | |
| EGT.4 | |
| EGT.3 | |
| EGT.2 | |
| EGT.1 | |
| EGT.0 | |

Block Wait Time Registers (BWTB0): 0xFE1B ← 0x00, (BWTB1): 0xFE1A ← 0x00, (BWTB2): 0xFE19 ← 0x00, (BWTB3): 0xFE18 ← 0x00

Table 104: The BWTB0 Register

| | | | | | | | |
|-------|-------|-------|-------|-------|-------|-------|-------|
| MSB | | | | LSB | | | |
| BWT.7 | BWT.6 | BWT.5 | BWT.4 | BWT.3 | BWT.1 | BWT.2 | BWT.0 |

Table 105: The BWTB1 Register

| | | | | | | | |
|--------|--------|--------|--------|--------|--------|-------|-------|
| MSB | | | | LSB | | | |
| BWT.15 | BWT.14 | BWT.13 | BWT.12 | BWT.11 | BWT.10 | BWT.9 | BWT.8 |

Table 106: The BWTB2 Register

| | | | | | | | |
|--------|--------|--------|--------|--------|--------|--------|--------|
| MSB | | | | LSB | | | |
| BWT.23 | BWT.22 | BWT.21 | BWT.20 | BWT.19 | BWT.18 | BWT.17 | BWT.16 |

Table 107: The BWTB3 Register

| | | | | | | | |
|-----|---|---|---|--------|--------|--------|--------|
| MSB | | | | LSB | | | |
| – | – | – | – | BWT.27 | BWT.26 | BWT.25 | BWT.24 |

These registers (BWTB0, BWTB1, BWTB2, BWTB3) are used to set the Block Waiting Time(27:0) (BWT). All of these parameters define the maximum time the 73S1217F will have to wait for a character from the smart card. These registers serve a dual purpose. When T=1, these registers are used to set up the block wait time. The block wait time defines the time in ETUs between the beginning of the last character sent to smart card and the start bit of the first character received from smart card. It can be used to detect an unresponsive card and should be loaded by firmware prior to writing the last TX byte. When T = 0, these registers are used to set up the work wait time. The work wait time is defined as the time between the leading edge of two consecutive characters being sent to or from the card. If a timeout occurs, an interrupt is generated to the firmware. The firmware can then take appropriate action. A Wait Time Extension (WTX) is supported with the 28-bit BWT.

Character Wait Time Registers (CWTB0): 0xFE1D ← 0x00, (CWTB1): 0xFE1C ← 0x00

Table 108: The CWTB0 Register

| | | | | | | | |
|-------|-------|-------|-------|-------|-------|-------|-------|
| MSB | | | | LSB | | | |
| CWT.7 | CWT.6 | CWT.5 | CWT.4 | CWT.3 | CWT.1 | CWT.2 | CWT.0 |

Table 109: The CWTB1 Register

| | | | | | | | |
|--------|--------|--------|--------|--------|--------|-------|-------|
| MSB | | | | LSB | | | |
| CWT.15 | CWT.14 | CWT.13 | CWT.12 | CWT.11 | CWT.10 | CWT.9 | CWT.8 |

These registers (CWTB0, CWTB1) are used to hold the Character Wait Time(15:0) (CWT) or Initial Waiting Time(15:0) (IWT) depending on the situation. Both the IWT and the CWT measure the time in ETUs between the leading edge of the start of the current character received from the smart card and the leading edge of the start of the next character received from the smart card. The only difference is the mode in which the card is operating. When T=1 these registers are used to configure the CWT and these registers configure the IWT when the ATR is being received. These registers should be loaded prior to receiving characters from the smart card. Firmware must manage which time is stored in the register. If a timeout occurs, an interrupt is generated to the firmware. The firmware can then take appropriate action.

ATR Timeout Registers (ATRLsB): 0xFE20 ← 0x00, (ATRMsb): 0xFE1F ← 0x00**Table 110: The ATRLsB Register**

| MSB | | | | | | | LSB |
|---------|---------|---------|---------|---------|---------|---------|---------|
| ATRTO.7 | ATRTO.6 | ATRTO.5 | ATRTO.4 | ATRTO.3 | ATRTO.1 | ATRTO.2 | ATRTO.0 |

Table 111: The ATRMsB Register

| MSB | | | | | | LSB | |
|----------|----------|----------|----------|----------|----------|---------|---------|
| ATRTO.15 | ATRTO.14 | ATRTO.13 | ATRTO.12 | ATRTO.11 | ATRTO.10 | ATRTO.9 | ATRTO.8 |

These registers (ATRLsB and ATRMsB) form the ATR timeout (ATRTO [15:0]) parameter. Time in ETU between the leading edge of the first character and leading edge of the last character of the ATR response. Timer is enabled when the RCVATR is set and starts when leading edge of the first start bit is received and disabled when the RCVATR is cleared. An ATR timeout is generated if this time is exceeded.

TS Timeout Register (STSTO): 0xFE21 ← 0x00**Table 112: The STSTO Register**

| MSB | | | | | | | LSB |
|--------|--------|--------|--------|--------|--------|--------|--------|
| TST0.7 | TST0.6 | TST0.5 | TST0.4 | TST0.3 | TST0.1 | TST0.2 | TST0.0 |

The TS timeout is the time in ETU between the de-assertion of smart card reset and the leading edge of the TS character in the ATR (when DETTS is set). The timer is started when smart card reset is de-asserted. An ATR timeout is generated if this time is exceeded (MUTE card).

Reset Time Register (RLength): 0xFE22 ← 0x70**Table 113: The RLength Register**

| MSB | | | | | | | LSB |
|--------|--------|--------|--------|--------|--------|--------|--------|
| RLen.7 | RLen.6 | RLen.5 | RLen.4 | RLen.3 | RLen.1 | RLen.2 | RLen.0 |

Time in ETUs that the hardware delays the de-assertion of RST. If set to 0 and RSTCRD = 0, the hardware adds no extra delay and the hardware will release RST after VCCOK is asserted during power-up. If set to 1, it will delay the release of RST by the time in this register. When the firmware sets the RSTCRD bit, the hardware will assert reset (RST = 0 on pin). When firmware clears the bit, the hardware will release RST after the delay specified in RLen. If firmware sets the RSTCRD bit prior to instructing the power to be applied to the smart card, the hardware will not release RST after power-up until RLen after the firmware clears the RSTCRD bit. This provides a means to power up the smart card and hold it in reset until the firmware wants to release the RST to the selected smart card. Works with the selected smart card interface.

Shaded locations indicate functions that are not provided in sync mode.

Table 114: Smart Card SFR Table

| Name | Address | b7 | b6 | b5 | b4 | b3 | b2 | b1 | b0 |
|----------|---------|------------------|----------|-------------|--------------|-------------|---------|---------|---------|
| SCSel | FE00 | | | | | SelSC(1:0) | | BYPASS | |
| SCInt | FE01 | WAITTO/ RLIEN | CRDEVT | VCCTMR | RXDAVI | TXEVNT | TXSENT | TXERR | RXERR |
| SCIE | FE02 | WTOI/ RLIEN | CDEVNT | VTMREN | RXDAEN | TXEVEN | TXSNTEN | TXERR | RXERR |
| VccCtl | FE03 | VCCSEL.1 | VCCSEL.0 | VDDFLT | RDYST | VCCOK | | | SCPWRDN |
| VccTmr | FE04 | OFFTMR(3:0) | | | | VCCTMR(3:0) | | | |
| CRDctl | FE05 | DEBOUN | CDETEN | | | DETPOL | PUENB | PDEN | CARDIN |
| STXctl | FE06 | I2CMODE | | TXFULL | TXEMTY | TXUNDR | LASTTX | TX/RXB | BREAKD |
| STXData | FE07 | TXDATA(7:0) | | | | | | | |
| SRXctl | FE08 | BIT9DAT | | LASTRX | CRCERR | RXFULL | RXEMTY | RXOVRR | PARITYE |
| SRXData | FE09 | RXDATA(7:0) | | | | | | | |
| SCctl | FE0A | RSTCRD | | IO | IOD | C8 | C4 | CLKLVL | CLKOFF |
| SCEctl | FE0B | | | SIO | SIOD | | | SCLKLVL | SCLKOFF |
| SCDIR | FE0C | | | | | C8D | C4D | | |
| SPrtcol | FE0D | I2CMODE | MOD9/8B | SCESYN | 0 | TMODE | CRCEN | CRCMS | RCVATR |
| SCCLK | FE0F | | | ICLKFS(5:0) | | | | | |
| SCECLK | FE10 | | | ECLKFS(5:0) | | | | | |
| SParCtl | FE11 | | DISPAR | BRKGEN | BRKDET | RTRAN | DISCRX | INSPE | FORCPE |
| SByteCtl | FE12 | | DETTS | DIRTS | BRKDUR (1:0) | | | | |
| FReg | FE13 | FVAL(3:0) | | | | DVAL (3:0) | | | |
| CRCMsB | FE14 | CRC(15:8) | | | | | | | |
| CRCLsB | FE15 | CRC(7:0) | | | | | | | |
| BGT | FE16 | EGT8 | | | | BGT(4:0) | | | |
| EGT | FE17 | EGT(7:0) | | | | | | | |
| BWTB3 | FE18 | | | | | BWT(27:24) | | | |
| BWTB2 | FE19 | BWT(23:16) | | | | | | | |
| BWTB1 | FE1A | BWT(15:8) | | | | | | | |
| BWTB0 | FE1B | BWT(7:0) | | | | | | | |
| CWTB1 | FE1C | CWT(15:8) | | | | | | | |
| CWTB0 | FE1D | CWT(7:0) | | | | | | | |
| ATRMsb | FE1F | ATRTO(15:8) | | | | | | | |
| ATRLsb | FE20 | ATRTO(7:0) | | | | | | | |
| STSTO | FE21 | TSTO(7:0) | | | | | | | |
| RLength | FE22 | RLen(7:0) | | | | | | | |

1.7.18 VDD Fault Detect Function

The 73S1217F contains a circuit to detect a low-voltage condition on the supply voltage V_{DD} . If enabled, it will deactivate the active internal smart card interface when V_{DD} falls below the V_{DD} Fault threshold. The register configures the V_{DD} Fault threshold for the nominal default of 2.3V* or a user selectable threshold. The user's code may load a different value using the FOVRVDDF bit =1 after the power-up cycle has completed

VDDFault Control Register (VDDFctl): 0xFFD4 ← 0x00

Table 115: The VDDFctl Register

| MSB | | | | LSB | | | |
|-----------|----------|---|-----------------------|----------|----------|----------|----------|
| – | FOVRVDDF | VDDFLTEN | – | STXDAT.3 | VDDFTH.2 | VDDFTH.1 | VDDFTH.0 |
| Bit | Symbol | Function | | | | | |
| VDDFctl.7 | – | | | | | | |
| VDDFctl.6 | FOVRVDDF | Setting this bit high will allow the VDDFLT(2:0) bits set in this register to control the VDDFault threshold. When this bit is set low, the VDDFault threshold will be set to the factory default setting of 2.3V*. | | | | | |
| VDDFctl.5 | VDDFLTEN | Set = 1 will disable VDD Fault operation. | | | | | |
| VDDFctl.4 | – | | | | | | |
| VDDFctl.3 | – | | | | | | |
| VDDFctl.2 | VDDFTH.2 | VDD Fault Threshold. | | | | | |
| | | Bit value(2:0) | VDDFault voltage | | | | |
| VDDFctl.1 | VDDFTH.1 | 000 | 2.3 (nominal default) | | | | |
| | | 001 | 2.4 | | | | |
| | | 010 | 2.5 | | | | |
| | | 011 | 2.6 | | | | |
| VDDFctl.0 | VDDFTH.0 | 100 | 2.7 | | | | |
| | | 101 | 2.8 | | | | |
| | | 110 | 2.9 | | | | |
| | | 111 | 3.0 | | | | |

* Note: The V_{DD} Fault factory default can be set to any threshold as defined by bits VDDFTH(2:0). The 73S1217F has the capability to burn fuses at the factory to set the factory default to any of these voltages. Contact Teridian for further details.

2 Application Schematics

2.1 Typical Application Schematic 1

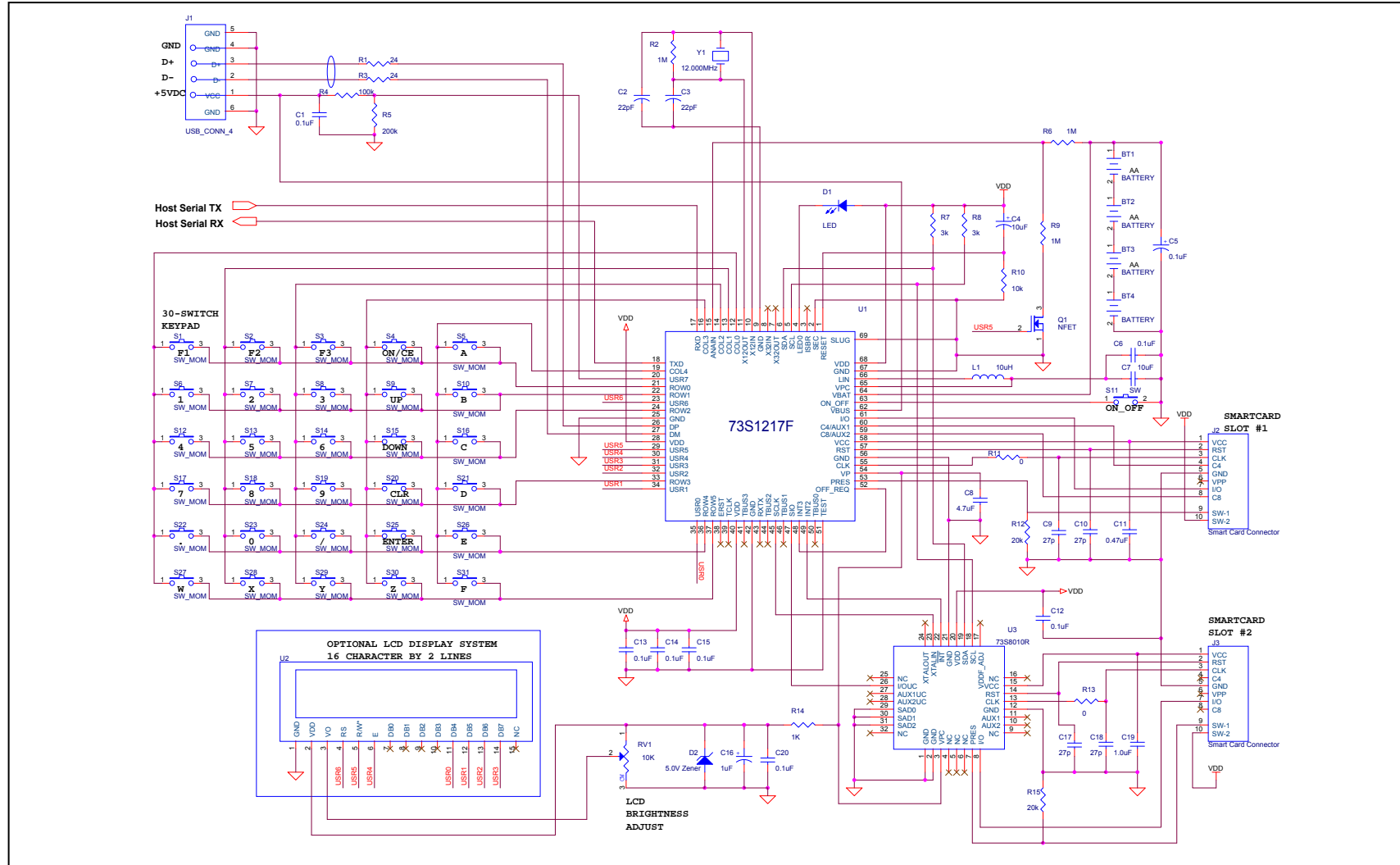

Figure 27: 73S1217F Typical Application Schematic (Handheld USB PINpad, with Combo USB-Bus and Self-powered Configuration)

2.2 Typical Application Schematic 2

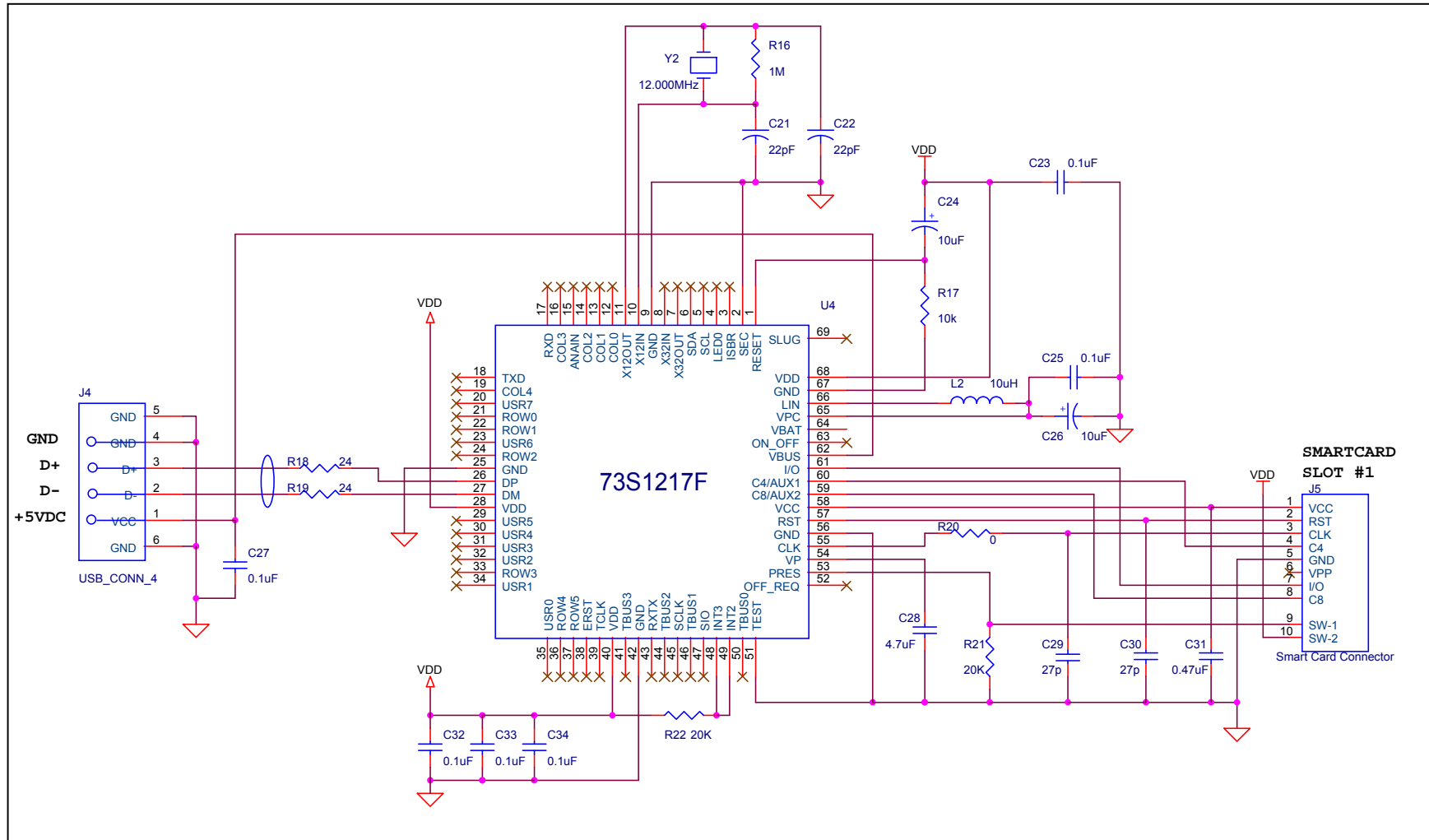

Figure 28: 73S1217F Typical Application Schematic (USB Transparent Reader and USB Key Configuration)

3 Electrical Specification

3.1 Absolute Maximum Ratings

Operation outside these rating limits may cause permanent damage to the device. The smart card interface pins are protected against short circuits to V_{CC} , ground, and each other.

| Parameter | Rating |
|---------------------------------------|------------------------------|
| DC Supply voltage, V_{DD} | -0.5 to 4.0 VDC |
| Supply Voltage V_{PC} | -0.5 to 6.6 VDC |
| Supply Voltage V_{BUS} | -0.5 to 6.6 VDC |
| Supply Voltage V_{BAT} | -0.5 to 6.6 VDC |
| Storage Temperature | -60° to 150°C |
| Pin Voltage (except card interface) | -0.3 to ($V_{DD}+0.5$) VDC |
| Pin Voltage (card interface) | -0.3 to ($V_{CC}+0.5$) VDC |
| ESD tolerance (except card interface) | +/- 2KV |
| ESD tolerance (card interface) | +/- 7KV |
| Pin Current | ± 200 mA |

Note: ESD testing on smart card pins is HBM condition, 3 pulses, each polarity referenced to ground.

Note: Smart Card pins are protected against shorts between any combinations of Smart Card pins.

3.2 Recommended Operating Conditions

Unless otherwise noted all specifications are valid over these temperatures and supply voltage ranges:

| Parameter | Rating |
|---|----------------|
| Supply Voltage V_{PC} | 2.7 to 6.5 VDC |
| Supply Voltage V_{BUS} | 4.4 to 5.5 VDC |
| Supply Voltage V_{BAT} | 4.0 to 6.5 VDC |
| Ambient Operating Temperature (T_a) | -40°C to +85°C |

3.3 Digital IO Characteristics

These requirements pertain to digital I/O pin types with consideration of the specific pin function and configuration. The Row pins have 100K Ω pull-ups.

| Symbol | Parameter | Conditions | Min. | Typ. | Max. | Unit |
|--------|---------------------|---|------------------------|------|----------------------|---------|
| Voh | Output level, high | Ioh = -2mA | 0.8 * V _{DD} | | V _{DD} | V |
| | | OFF_REQ pin - I _{OH} = -1mA | V _{DD} - 0.45 | | | V |
| Vol | Output level, low | Iol = 2mA | 0 | | 0.3 | V |
| | | OFF_REQ pin - Iol = 2mA | | | 0.45 | V |
| Vih | Input voltage, high | 2.7v < VDD < 3.6v | 1.8 | | V _{DD} +0.3 | V |
| Vil | Input voltage, low | 2.7v < VDD < 3.6v | -0.3 | | 0.6 | V |
| | | RESET, ON_OFF, PRES pins | -0.3 | | 0.8 | V |
| Ileak | Leakage current | 0 < Vin < VDD All output modes disabled, pull-up/downs disabled | -5 | | 5 | μ A |
| Ipu | Pull-up current | If provided and enabled, Vout < 0.1v | -5 | -3 | | μ A |
| Ipd | Pull-down current | If provided and enabled, Vout > VDD - 0.1v | | 3 | 5 | μ A |

| Symbol | Parameter | Conditions | Min. | Typ. | Max. | Unit |
|---------|-----------------------------------|--|------|------|------|---------|
| Iled | LED drive current | Vout = 1.3V, 2.7v < VDD < 3.6v | 1.7 | 2 | 2.3 | mA |
| | | | 3.4 | 4 | 4.6 | |
| | | | 8.5 | 10 | 11.5 | |
| Iolkrow | Keypad Row output low current | 0.0v < Voh < 0.1v when pull-up R is enabled | | -40 | -100 | μ A |
| Iolkcol | Keypad column output high current | 0.0v < Voh < 0.1v when col. is pulled low | | -1.5 | -3 | mA |

3.4 Oscillator Interface Requirements

| Symbol | Parameter | Condition | Min | Typ. | Max | Unit |
|---|----------------------------|------------------|---------|------|---------|---------|
| Low-Power Oscillator Requirements. No External Load Beside The Crystal And Capacitor Is Permitted On Xout32 | | | | | | |
| Pxtal | Power in crystal | | | | 1 | μ W |
| IIL | Input Leakage Current | GND < Vin < VDD | -5 | | 5 | μ A |
| High-frequency oscillator (XIN) Parameters. XIN is used as input for external clock for test purposes only. A resistor connecting X12IN to X12OUT is required, value = 1MΩ | | | | | | |
| VILX12IN | Input Low Voltage – X12IN | | -0.3 | | 0.3*VDD | V |
| VIHX12IN | Input High Voltage – X12IN | | 0.7*VDD | | Vdd+0.3 | V |
| IILXTAL | Input Current -X12IN | GND < Vin < Vdd | -10 | | 10 | μ A |
| Fxtal | Crystal resonant frequency | Fundamental mode | 6 | | 12 | MHz |

3.5 DC Characteristics: Analog Input

| Symbol | Parameter | Condition | Min | Typ. | Max | Unit |
|---------------------|-----------------------------|--------------------------|-----|------|-----|------|
| V _{TH} TOL | Voltage Threshold Tolerance | Selected Threshold Value | -3% | | +3% | V |

3.6 USB Interface Requirements

| Parameter | | Condition | Min | Typ. | Max | Unit |
|---------------------------------------|------|---------------------------------|------------|------|-----|------------|
| Receiver Parameters | | | | | | |
| Differential input sensitivity | VDI | $(DP)-(DM)$ | 0.2 | | | V |
| Differential common mode range | VCM | Includes VDI range | 0.8 | | 2.5 | V |
| Single ended receiver threshold | VSE | | 0.8 | | 2.0 | V |
| Transmitter Levels | | | | | | |
| Low Level Output Voltage | VOL | USBCon = 1 (DP pullup enabled) | | | 0.3 | V |
| High Level Output Voltage | VOH | 15K Ω resistor to ground | VDD – 0.1V | | VDD | V |
| Output Resistance (1) | | | | | | |
| Driver output resistance | ZDRV | Steady state drive ¹ | 28 | | 44 | Ω |
| PD Pullup Resistor (to VDD) | Zpu | USBCon = 1 | 1.2 | 1.5 | 1.8 | k Ω |
| Transceiver Power Requirements | | | | | | |
| Operating supply current(output) | IPSO | Outputs enabled | | | 5 | mA |
| Operating supply current (input) | IPSI | Outputs Hi-Z | | | 1 | mA |
| Supply current in powerdown | IPDN | | | | 10 | nA |
| Supply current in suspend. | IPSS | | | | 10 | nA |

¹ External source (series) termination resistors of 24 Ω must be included on circuit board.

| Parameter | | Condition | Min | Typ. | Max | Unit |
|--|-------|---|-------|------|--------|------|
| C_L = 50pf, series 24Ω, 1% source termination resistor included | | | | | | |
| Rise Time | USBTR | 10% to 90% | 4 | | 20 | ns |
| Fall Time | USBTF | 90% to 10% | 4 | | 20 | ns |
| Rise/fall time matching | TRFM | (USBTR/USBTF) | 90 | | 111.11 | % |
| Output signal crossover voltage | VCRS | Includes VDI range | 1.3 | | 2.0 | V |
| Source Jitter to Next Transition | TDJ1 | Measured as in Figure 7-49 of USB 2.0 Spec | -3.5 | | 3.5 | ns |
| Source Jitter For Paired Transitions | TDJ2 | Measured as in Figure 7-49 of USB 2.0 Spec (1) (2) | -4 | | 4 | ns |
| Receiver Jitter to Next Transition | TJR1 | Measure as in Figure 7-51 of USB 2.0 Spec. Characterized but not production tested. | -18.5 | | 18.5 | ns |
| Receiver Jitter for Paired Transitions | TJR2 | Measure as in Figure 7-51 of USB 2.0 Spec. Characterized but not production tested. | -9 | | 9 | ns |
| Source SEO interval of EOP | TEOPT | Figure 7-50 of USB 2.0 Spec | 160 | | 175 | ns |
| Receiver SEO interval of EOP | TEOPR | Figure 7-50 of USB 2.0 Spec. (3) | 82 | | | ns |

- (1) For both transitions of differential signaling.
(2) Excluding first transition from the Idle state.
(3) Must accept as valid EOP.

3.7 Smart Card Interface Requirements

| Symbol | Parameter | Condition | Min | Typ. | Max | Unit |
|---|--|--|------|------|------|------------------|
| Card Power Supply (V_{CC}) Regulator | | | | | | |
| General conditions, $-40^{\circ}\text{C} < T < 85^{\circ}\text{C}$, $4.75\text{V} < V_{PC} < 6.0\text{V}$, $2.7\text{V} < V_{DD} < 3.6\text{V}$ | | | | | | |
| V_{CC} | Card supply Voltage including ripple and noise | Inactive mode | -0.1 | | 0.1 | V |
| | | Inactive mode, $I_{CC} = 1\text{mA}$ | -0.1 | | 0.4 | V |
| | | Active mode; $I_{CC} < 65\text{mA}$; 5V | 4.65 | | 5.25 | V |
| | | Active mode; $I_{CC} < 65\text{mA}$; 3V | 2.85 | | 3.15 | V |
| | | Active mode; $I_{CC} < 40\text{mA}$; 1.8V | 1.68 | | 1.92 | V |
| | | Active mode; single pulse of 100mA for 2 μs ; 5 volt, fixed load = 25mA | 4.6 | | 5.25 | V |
| | | Active mode; single pulse of 100mA for 2 μs ; 3V, fixed load = 25mA | 2.76 | | 3.15 | V |
| | | Active mode; current pulses of 40nAs with peak $ I_{CC} < 200\text{mA}$, t < 400ns; 5V | 4.6 | | 5.25 | V |
| | | Active mode; current pulses of 40nAs with peak $ I_{CC} < 200\text{mA}$, t < 400ns; 3V | 2.7 | | 3.15 | V |
| | | Active mode; current pulses of 20nAs with peak $ I_{CC} < 100\text{mA}$, t < 400ns; 1.8V | 1.62 | | 1.92 | V |
| V_{CCrip} | V_{CC} Ripple | $f_{RIPPLE} = 20\text{kHz} - 200\text{MHz}$ | | | 350 | mV |
| I_{CCmax} | Card supply output current | Static load current, $V_{CC} > 1.65$ | | | 40 | mA |
| | | Static load current, $V_{CC} > 4.6$ or 2.7 volts as selected | | | 65 | mA |
| I_{CCF} | I_{CC} fault current | Class A, B (5V and 3V) | 100 | | 180 | mA |
| | | Class C (1.8V) | 60 | | 130 | |
| V_{SR} | V_{CC} slew rate, rise | Rise rate on activate C = 0.47 μF | 0.12 | .30 | 0.50 | V/ μs |
| V_{SF} | V_{CC} slew rate, fall | Fall rate on deactivate, C = 0.47 μF | 0.15 | .30 | 1.20 | V/ μs |
| V_{rdy} | V_{CC} ready voltage ($V_{CCOK} = 1$) | 5V operation, V_{CC} rising | 4.6 | | | V |
| | | 3V operation, V_{CC} rising | 2.75 | | | V |
| | | 1.8V operation, V_{CC} rising | 1.65 | | | V |

| Symbol | Parameter | Condition | Min | Typ. | Max | Unit |
|--|--|--|-----------------------|------|-----------------------|------|
| Interface Requirements – Data Signals: I/O, AUX1 and AUX2 | | | | | | |
| V _{OH} | Output level, high | I _{OH} = 0 | 0.9 * V _{CC} | | V _{CC} +0.1 | V |
| | | I _{OH} = -40μA | 0.75 V _{CC} | | V _{CC} +0.1 | V |
| V _{OL} | Output level, low | I _{OL} = 1mA | | | 0.15 *V _{CC} | V |
| V _{IH} | Input level, high | | 0.6 * V _{CC} | | V _{CC} +0.30 | V |
| V _{IL} | Input level, low | | -0.15 | | 0.2 * V _{CC} | V |
| V _{INACT} | Output voltage when outside of session | I _{OL} = 0 | | | 0.1 | V |
| | | I _{OL} = 1mA | | | 0.3 | V |
| I _{LEAK} | Input leakage | V _{IH} = V _{CC} | | | 10 | μA |
| I _{IL} | Input current, low | V _{IL} = 0 | | | 0.65 | mA |
| I _{IL} | Input current, low | V _{IL} = 0 | | | 0.7 | mA |
| I _{SHORTL} | Short circuit output current | For output low, shorted to V _{CC} through 33Ω | | | 15 | mA |
| I _{SHORTH} | Short circuit output current | For output high, shorted to ground through 33Ω | | | 15 | mA |
| t _R , t _F | Output rise time, fall times | For I/O, AUX1, AUX2, C _L = 80pF, 10% to 90%. For I/OUC, AUX1UC, AUX2UC, C _L = 50Pf, 10% to 90%. | | | 100 | ns |
| t _{IR} , t _{IF} | Input rise, fall times | | | | 1 | μs |
| R _{PU} | Internal pull-up resistor | Output stable for >200ns | 8 | 11 | 14 | kΩ |
| FD _{MAX} | Maximum data rate | | | | 1 | MHz |
| Reset and Clock for Card Interface, RST, CLK | | | | | | |
| V _{OH} | Output level, high | I _{OH} = -200μA | 0.9 * V _{CC} | | V _{CC} | V |
| V _{OL} | Output level, low | I _{OL} = 200μA | 0 | | 0.15 *V _{CC} | V |
| V _{INACT} | Output voltage when outside of session | I _{OL} = 0 | | | 0.1 | V |
| | | I _{OL} = 1mA | | | 0.3 | V |
| I _{RST_LIM} | Output current limit, RST | | | | 30 | mA |
| I _{CLK_LIM} | Output current limit, CLK | | | | 70 | mA |
| t _R , t _F | Output rise time, fall time | C _L = 35pF for CLK, 10% to 90% | | | 8 | ns |
| | | C _L = 200pF for RST, 10% to 90% | | | 100 | ns |
| δ | Duty cycle for CLK | C _L = 35pF, F _{CLK} ≤ 20MHz, CLKIN duty cycle is 48% to 52%. | 45 | | 55 | % |

3.8 DC Characteristics

| Symbol | Parameter | Condition | Min | Typ. | Max | Unit |
|-------------------|--|---------------------|-----|------|-----|------|
| I _{PC} | Supply Current @ V _{PC} = 2.7V (V _{BUS} and V _{BAT} unconnected) | CPU clock @ 24MHz | 52 | 65 | 78 | mA |
| | | CPU clock @ 12MHz | 39 | 48 | 58 | mA |
| | | CPU clock @ 6MHz | 31 | 39 | 46 | mA |
| | | CPU clock @ 3.69MHz | 28 | 35 | 42 | mA |
| | Supply Current @ V _{PC} = 3.3V (V _{BUS} and V _{BAT} unconnected) | CPU clock @ 24MHz | 40 | 50 | 60 | mA |
| | | CPU clock @ 12MHz | 30 | 37 | 45 | mA |
| | | CPU clock @ 6MHz | 24 | 30 | 36 | mA |
| | | CPU clock @ 3.69MHz | 22 | 27 | 32 | mA |
| | Supply Current @ V _{PC} = 5.0V (V _{BUS} and V _{BAT} unconnected) | CPU clock @ 24MHz | 24 | 30 | 35 | mA |
| | | CPU clock @ 12MHz | 18 | 22 | 26 | mA |
| | | CPU clock @ 6MHz | 14 | 18 | 21 | mA |
| | | CPU clock @ 3.69MHz | 13 | 16 | 19 | mA |
| I _{VBUS} | Supply Current @ V _{VBUS} = 4.4V | CPU clock @ 24MHz | 19 | 23 | 28 | mA |
| | | CPU clock @ 12MHz | 14 | 17 | 21 | mA |
| | | CPU clock @ 6MHz | 11 | 14 | 17 | mA |
| | | CPU clock @ 3.69MHz | 10 | 13 | 15 | mA |
| | Supply Current @ V _{VBUS} = 5.0V | CPU clock @ 24MHz | 19 | 23 | 28 | mA |
| | | CPU clock @ 12MHz | 14 | 17 | 21 | mA |
| | | CPU clock @ 6MHz | 11 | 14 | 17 | mA |
| | | CPU clock @ 3.69MHz | 10 | 13 | 15 | mA |
| | Supply Current @ V _{VBUS} = 5.5V | CPU clock @ 24MHz | 19 | 23 | 28 | mA |
| | | CPU clock @ 12MHz | 14 | 17 | 21 | mA |
| | | CPU clock @ 6MHz | 11 | 14 | 17 | mA |
| | | CPU clock @ 3.69MHz | 10 | 13 | 15 | mA |

| Symbol | Parameter | Condition | Min | Typ. | Max | Unit |
|-------------------|--|------------------------|-----|------|-----|------|
| I _{VBAT} | Supply Current @ V _{VBAT} = 4.0V (V _{BUS} = 0V) | CPU clock @ 24MHz | 32 | 40 | 49 | mA |
| | | CPU clock @ 12MHz | 24 | 30 | 36 | mA |
| | | CPU clock @ 6MHz | 19 | 24 | 29 | mA |
| | | CPU clock @ 3.69MHz | 17 | 22 | 26 | mA |
| | Supply Current @ V _{VBAT} = | CPU clock @ 24MHz | 24 | 30 | 36 | mA |

| | | | | | | |
|----------------------------------|---|---|-----|------|------|---------|
| | 5.0V ($V_{BUS} = 0V$) | CPU clock @ 12MHz | 18 | 22 | 27 | mA |
| | | CPU clock @ 6MHz | 14 | 18 | 21 | mA |
| | | CPU clock @ 3.69MHz | 13 | 16 | 19 | mA |
| | Supply Current @ $V_{VBAT} = 6.5V$ ($V_{BUS} = 0V$) | CPU clock @ 24MHz | 19 | 23 | 28 | mA |
| | | CPU clock @ 12MHz | 14 | 17 | 21 | mA |
| | | CPU clock @ 6MHz | 11 | 14 | 17 | mA |
| | | CPU clock @ 3.69MHz | 10 | 13 | 15 | mA |
| V_{DD} | V_{DD} Supply Voltage | $2.7V < V_{PC} < 6.5V$, $I_{VDD} < 40mA$. | 3.0 | 3.3 | 3.6 | V |
| I_{DD_IN} | Supply Current (pins 28 and 40) | CPU clock @ 24MHz | | 29 | 33.5 | mA |
| | | CPU clock @ 12MHz | | 21 | 24 | mA |
| | | CPU clock @ 6MHz | | 15.5 | 18 | mA |
| | | CPU clock @ 3.69MHz | | 13.5 | 15.5 | mA |
| | | Power down (-40° to 85°C) | | 8 | 50 | μA |
| | | Power down (25°C) | | 6 | 13 | μA |
| I_{DD_OUT} | Supply Current – pin 68 (available to external circuitry) | Circuit ON | | | 20 | mA |
| I_{VBUS} | Supply Current from V_{BUS} | V_{CC} off, $I_{DDINTERNAL} < 20\mu A$ | | 0.2 | 0.4 | mA |
| I_{VBAT} I_{VPC} | Supply Current from V_{BAT} or V_{PC} | Circuit OFF | | 0.01 | 1 | μA |
| $VBUS_{ON}$ | V_{BUS} detection threshold | | | 3.5 | | V |
| $VBUS_{IDIS}$ | V_{BUS} discharge current | | | 50 | | μA |
| External Capacitor Values | | | | | | |
| C_{VPC} | External filter capacitor for V_{PC} | | 8.0 | 10.0 | 12.0 | μF |
| C_{VP} | External filter capacitor for V_P | | 2.0 | 4.7 | 10.0 | μF |
| C_{VDD}^* | External filter capacitors for V_{DD} | | 0.2 | | 1.0 | μF |
| C_{VCC} | External filter capacitor for V_{CC} | C_{VCC} should be ceramic with low ESR (<100M Ω). | 0.2 | 0.47 | 1.0 | μF |

*Note: Recommend on 0.1 μF for each V_{DD} pin.

3.9 Current Fault Detection Circuits

| Symbol | Parameter | Condition | Min | Typ. | Max | Unit |
|----------------|--------------------------|-----------------|-----|------|-----|------|
| $I_{V_{Pmax}}$ | V_P over current fault | | | | 150 | mA |
| I_{DDmax} | VDD over-current limit | | 40 | | 100 | mA |
| I_{CCF} | Card overcurrent fault | | 80 | | 150 | mA |
| I_{CCF1P8} | Card overcurrent fault | $V_{CC} = 1.8V$ | 60 | | 130 | mA |

4 Equivalent Circuits

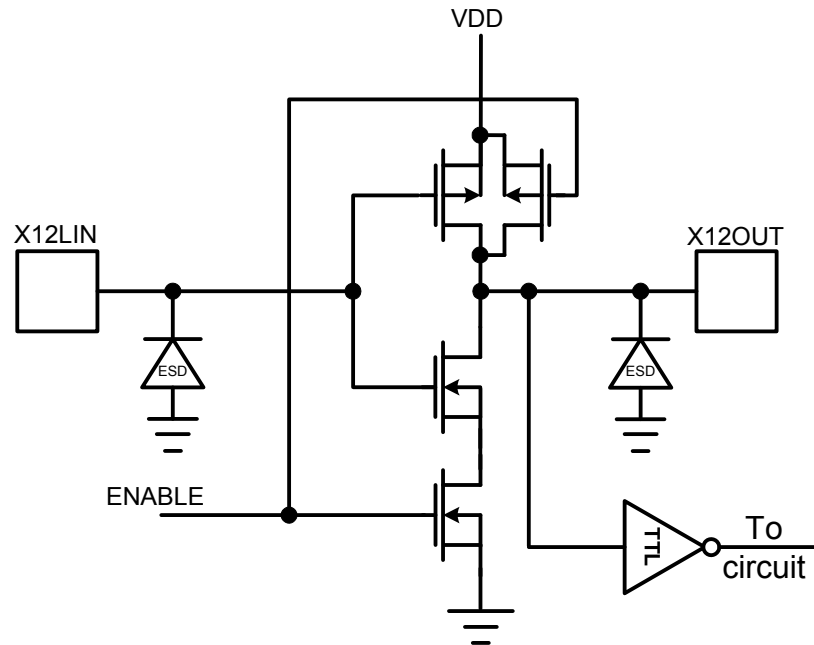

Figure 29: 12 MHz Oscillator Circuit

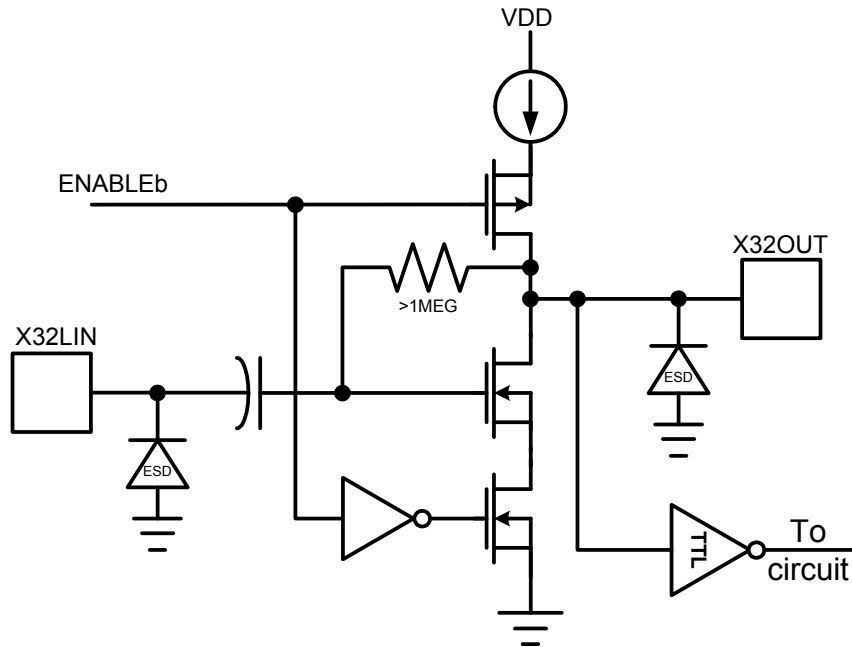

Figure 30: 32KHz Oscillator Circuit

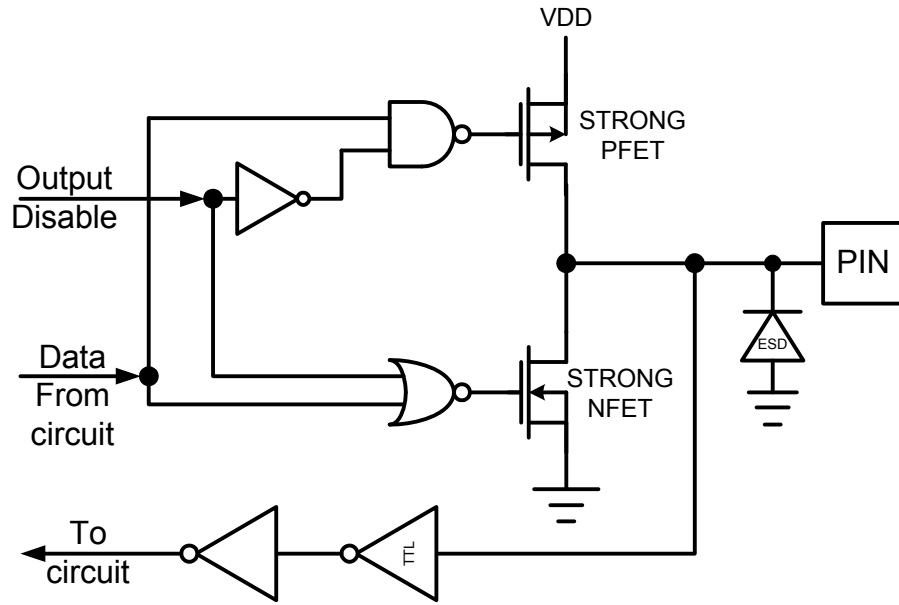

Figure 31: Digital I/O Circuit

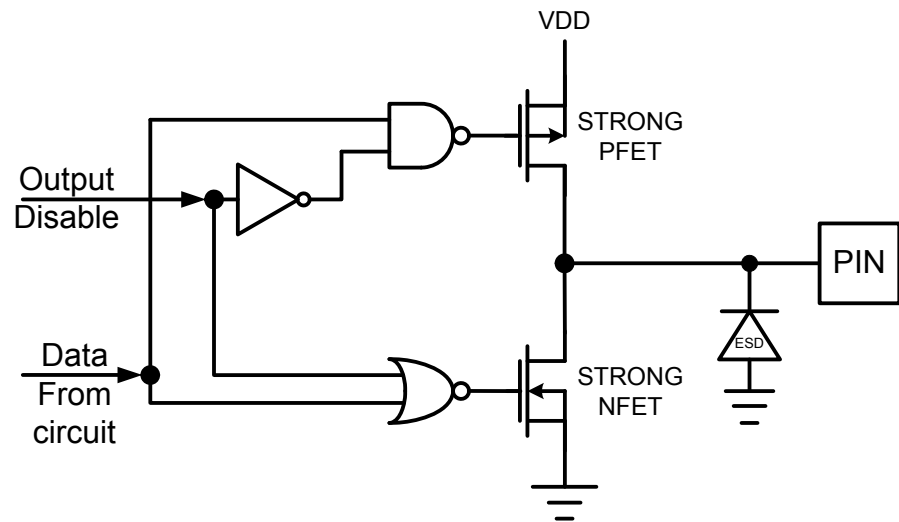

Figure 32: Digital Output Circuit

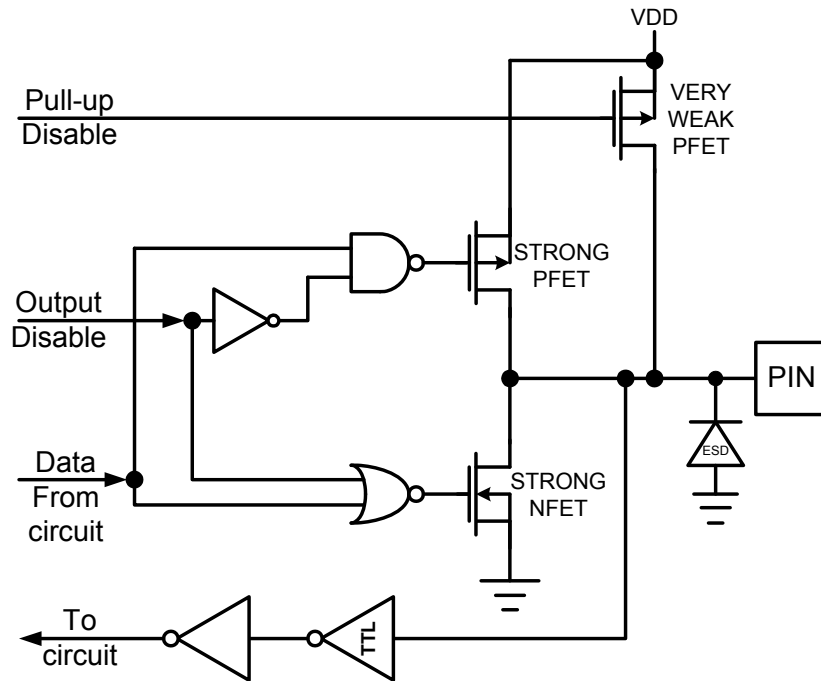

Figure 33: Digital I/O with Pull Up Circuit

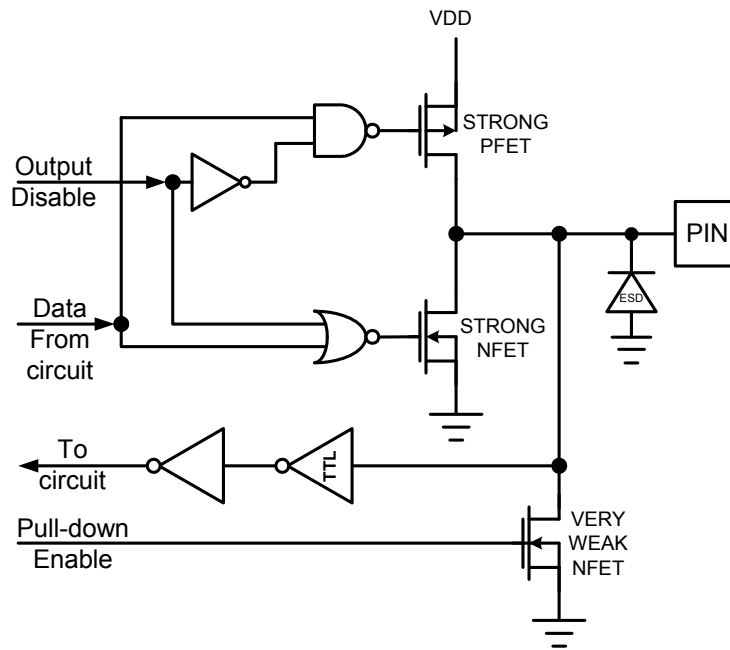

Figure 34: Digital I/O with Pull Down Circuit

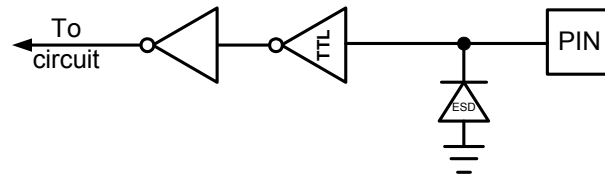

Figure 35: Digital Input Circuit

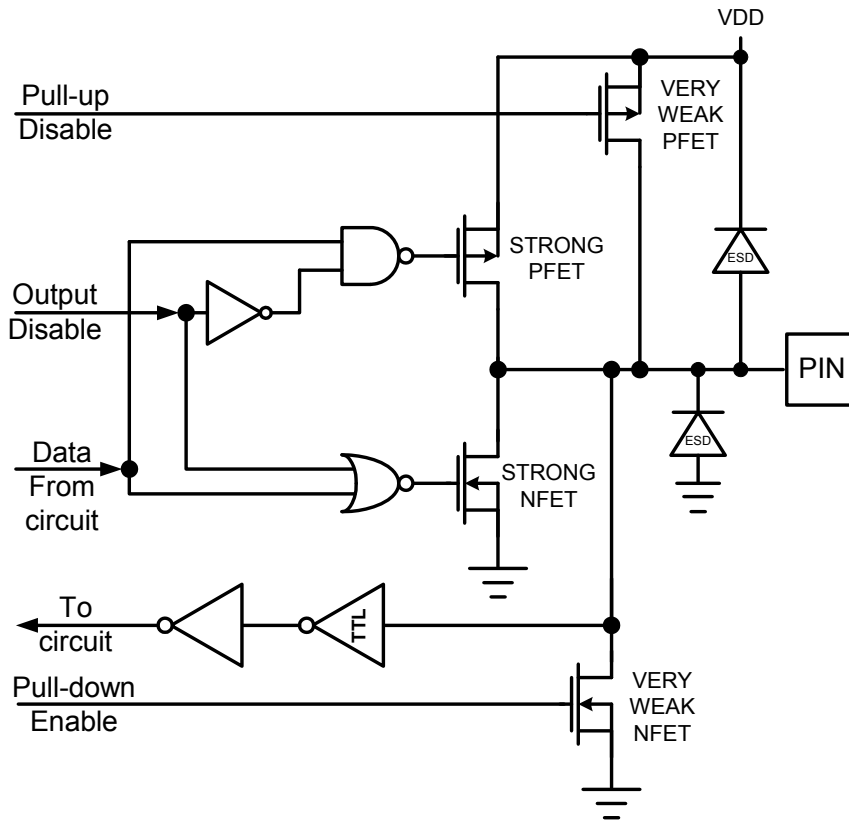

Figure 36: OFF_REQ Interface Circuit

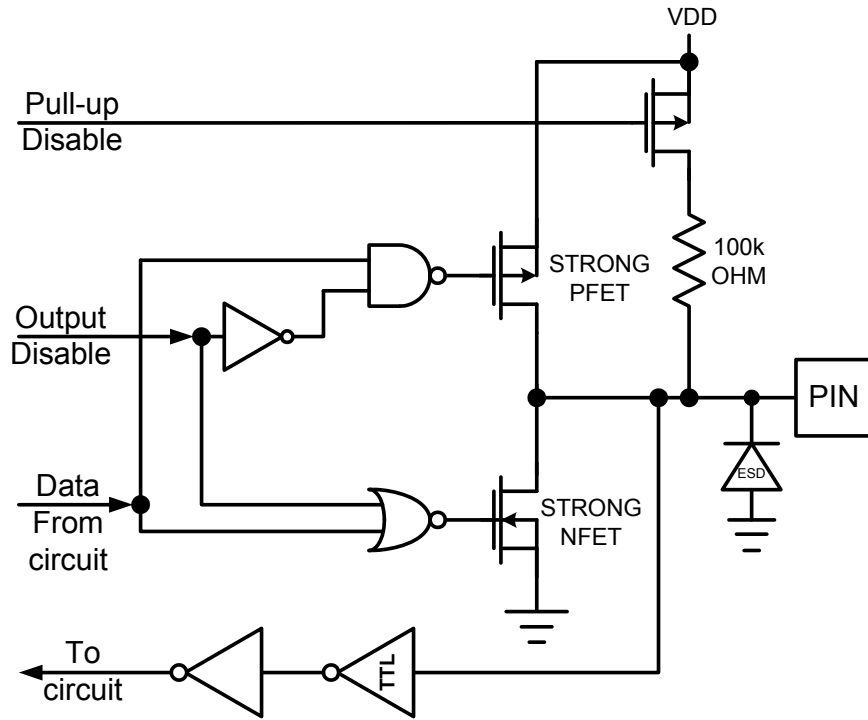

Figure 37: Keypad Row Circuit

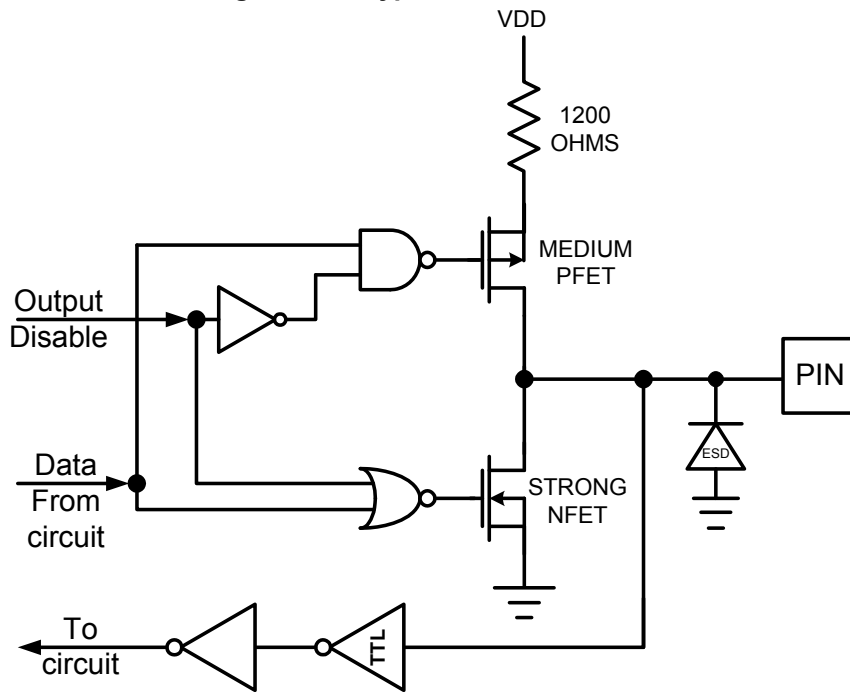

Figure 38: Keypad Column Circuit

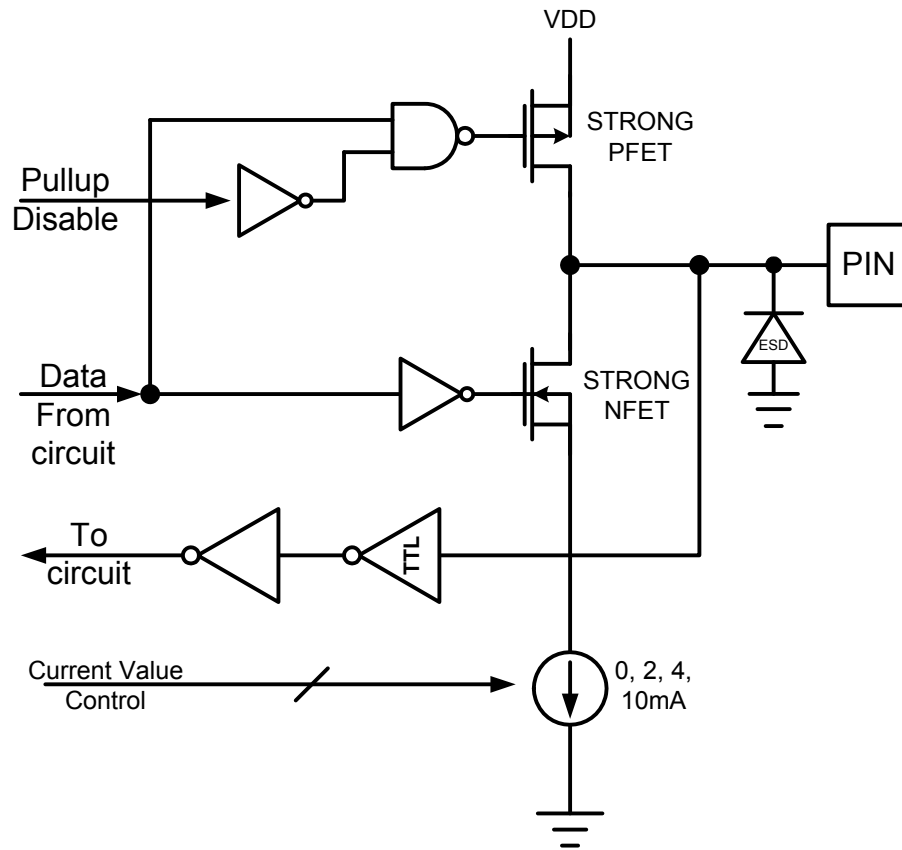

Figure 39: LED Circuit

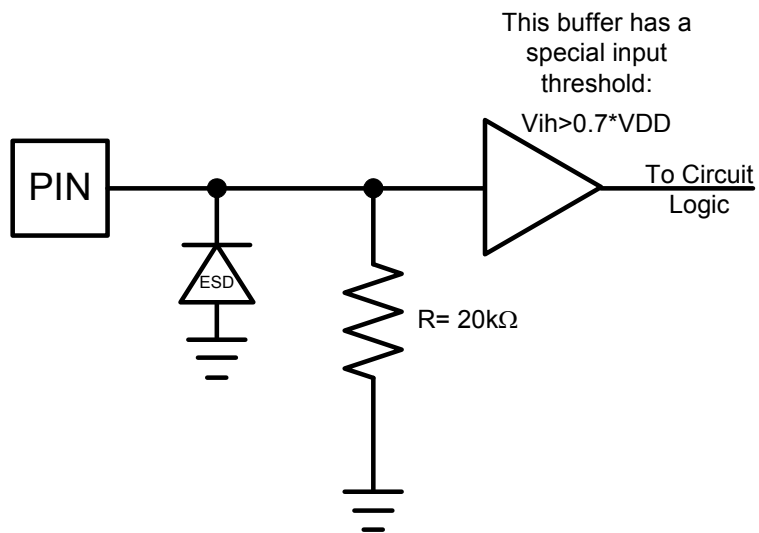

Figure 40: Test and Security Pin Circuit

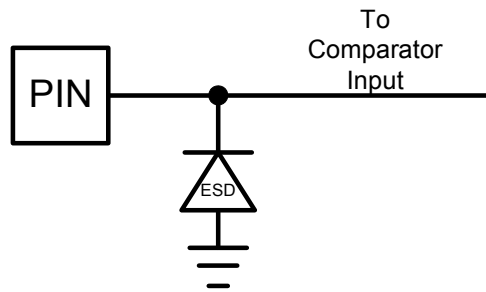

Figure 41: Analog Input Circuit

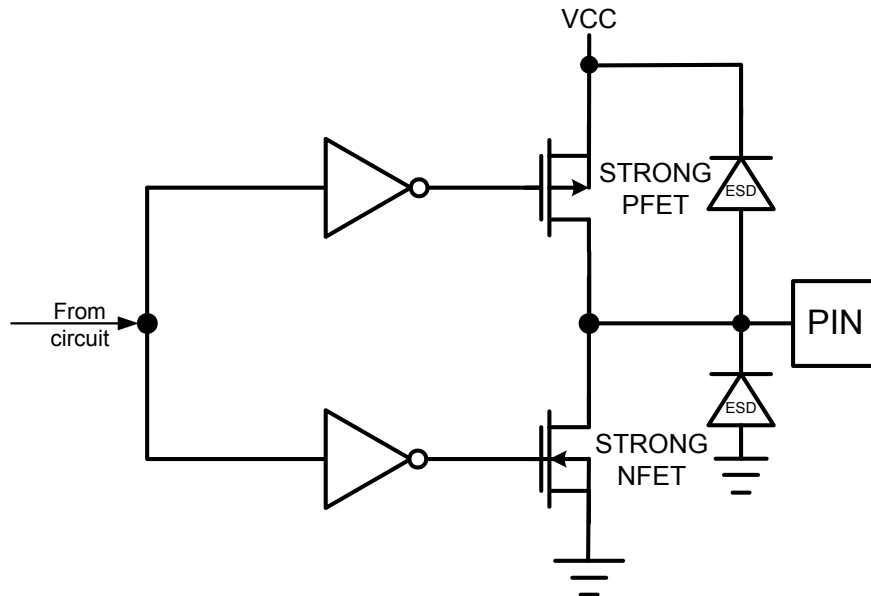

Figure 42: Smart Card Output Circuit

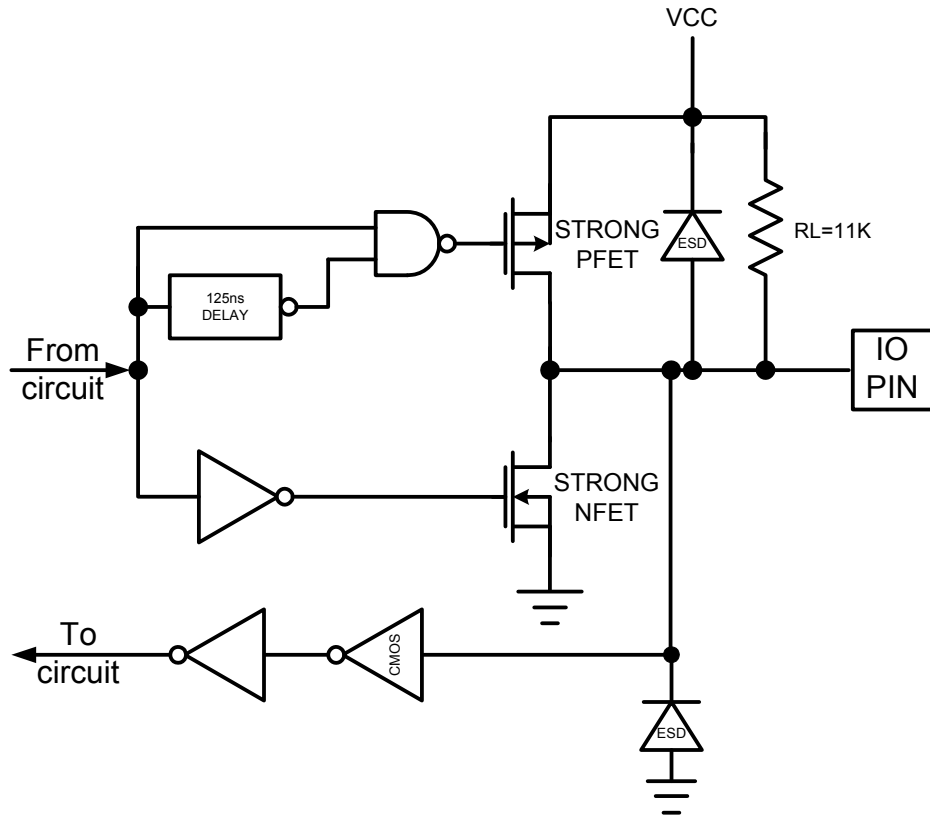

Figure 43: Smart Card I/O Circuit

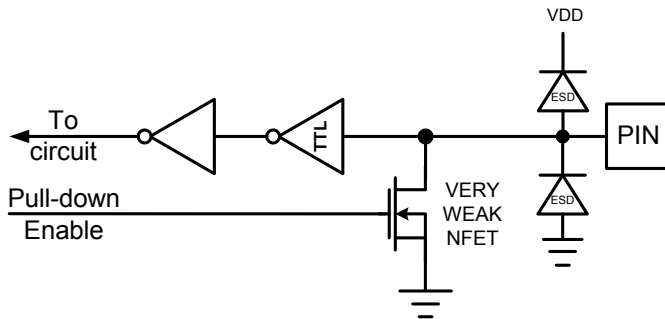

Figure 44: PRES Input Circuit

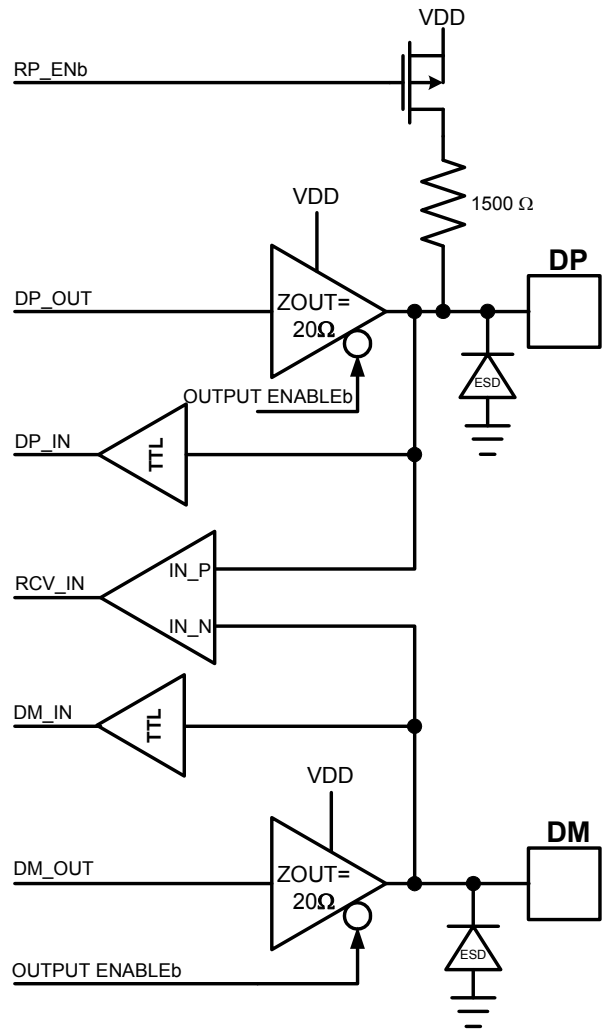

Figure 45: USB Circuit

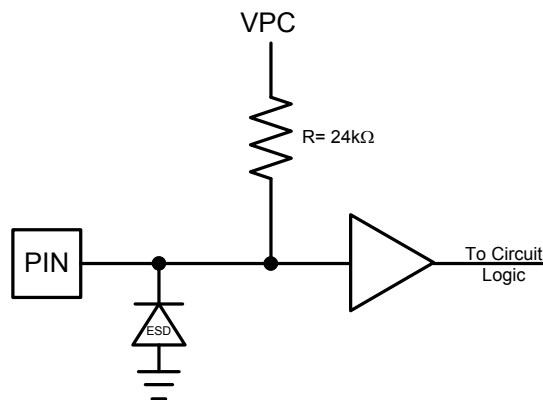

Figure 46: ON_OFF Input Circuit

4.1 Package Pin Designation (68-Pin QFN)

CAUTION: Use handling procedures necessary for a static sensitive component

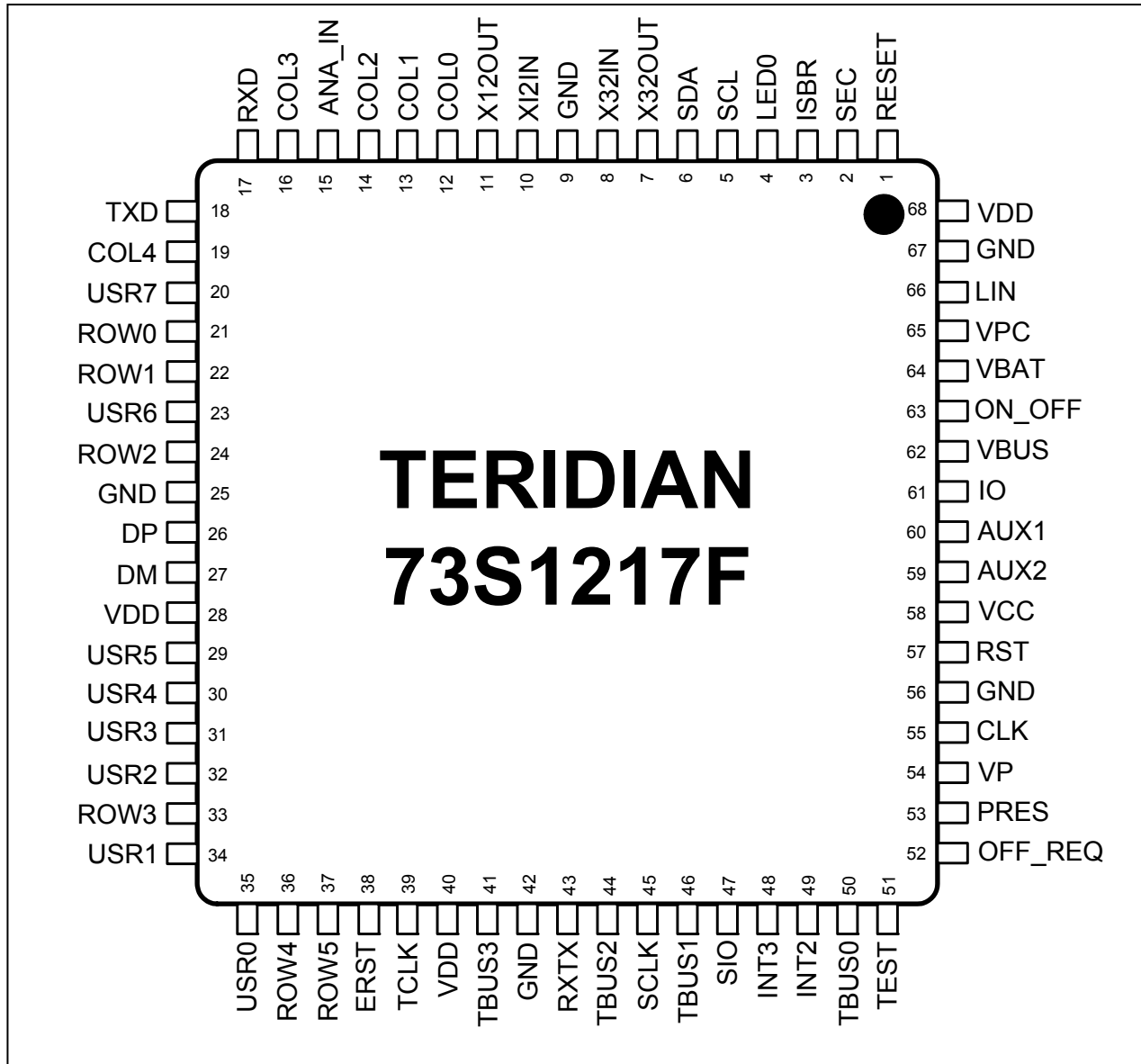

Figure 47: 73S1217F Pinout

4.2 Packaging Information

68-Pin QFN Package Outline

Notes: 6.3mm x 6.3mm exposed pad area must remain UNCONNECTED (clear of PCB traces or vias). Controlling dimensions are in mm.

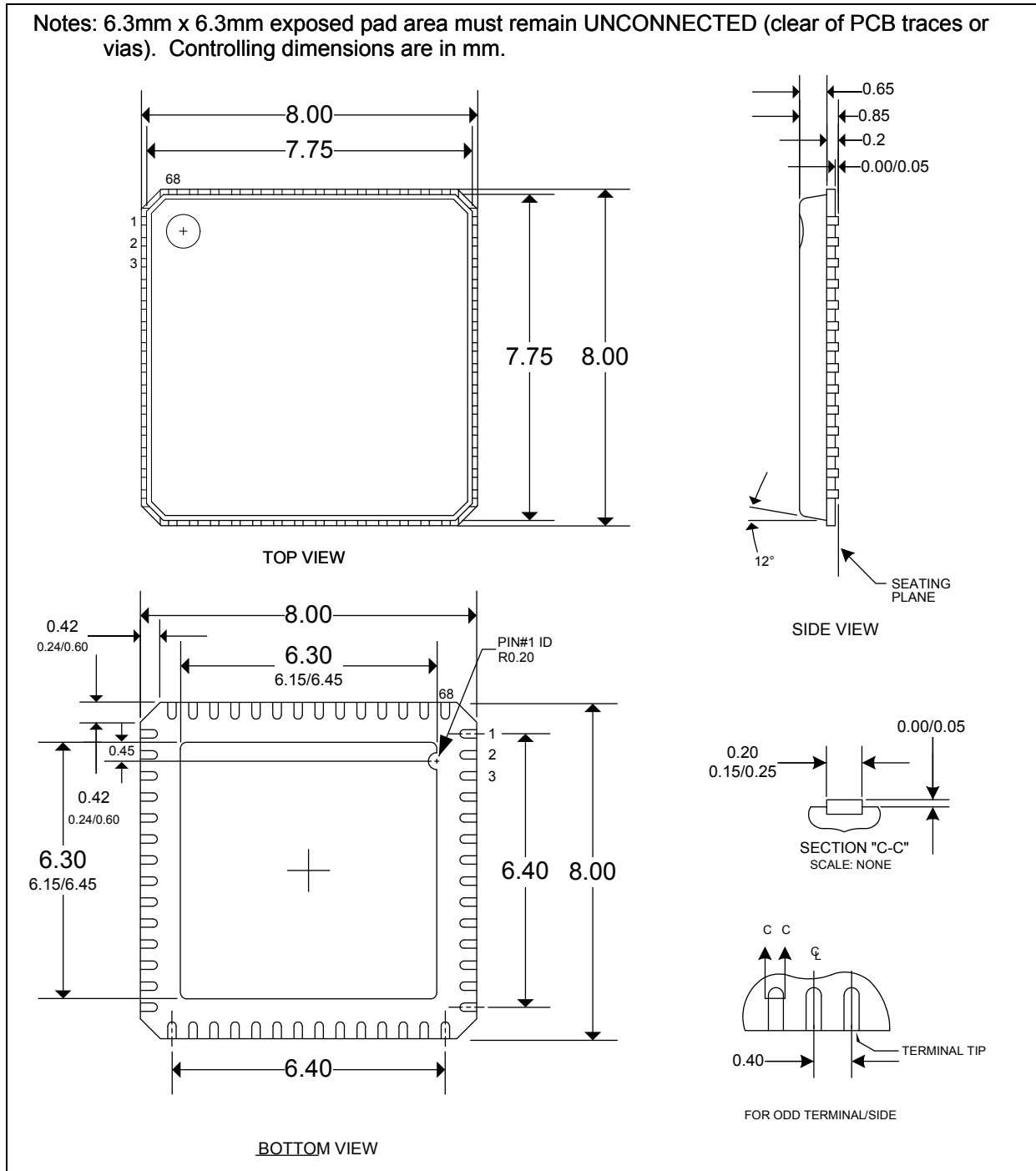

Figure 48: 73S1217F 68 QFN Mechanical Drawing

5 Ordering Information

Table 116 lists the order numbers and packaging marks used to identify 73S1217F products.

Table 116: Order Numbers and Packaging Marks

| Part Description | Order Number | Packaging Mark |
|---|-----------------|----------------|
| 73S1217F 68-Pin QFN, Lead Free | 73S1217F-68IM/F | 73S1217F68IM |
| 73S1217F 68-Pin QFN, Lead Free, Tape and Reel | 73S1217F-IMR/F | 73S1217F68IM |

6 Related Documentation

The following 73S1217F documents are available from Teridian Semiconductor Corporation:

73S1217F Data Sheet (this document)
73S1217F Development Board Quick Start Guide
73S1217F Software Development Kit Quick Start Guide
73S1217F Evaluation Board User's Guide
73S12xxF Software User's Guide
73S12xxF Synchronous Card Design Application Note

7 Contact Information

For more information about Teridian Semiconductor products or to check the availability of the 73S1217F, contact us at:

6440 Oak Canyon Road
 Suite 100
 Irvine, CA 92618-5201

Telephone: (714) 508-8800
 FAX: (714) 508-8878
 Email: scr.support@teridian.com

For a complete list of worldwide sales offices, go to <http://www.teridian.com>.

Revision History

| Revision | Date | Description |
|----------|------------|--|
| 1.0 | 5/15/2007 | First publication. |
| 1.1 | 11/7/2007 | <p>On page 2, changed bullet from “ISO-7816 UART 9600 to 115kbps for protocols T=0, T=1” to “ISO-7816 UART for protocols T=0, T=1”.</p> <p>In Table 1, removed NC, pin 44 row.</p> <p>In Section 1.4, changed description to remove pre-boot and 32-cycle references.</p> <p>In Section 1.4, changed the second bullet “Page zero of flash memory, the preferred location for the user’s preboot code, may not be page-erased by either MPT or ICE. Page zero may only be erased with global flash erase. Note that global flash erase erases XRAM whether the SECURE bit is set or not.” to “Page zero of flash memory may not be page-erased by either MPU or ICE. Page zero may only be erased with global flash erase. Note that global flash erase erases XRAM whether the SECURE bit is set or not.”</p> <p>In Section 1.7.1, changed “Mcount is configured in the MCLKCtl register must be bound between a value of 1 to 7. The possible crystal or external clock are shown in Table 12.” to “Mcount is configured in the MCLKCtl register must be bound between a value of 1 to 7. The possible crystal or external clock frequencies for getting MCLK = 96MHz are shown in Table 11.”</p> <p>In Section 1.7.4, added “Depending on the state of the ON/OFF circuitry and power applied to the VBUS input, the 73S1217F will go into either standby mode or power “OFF” mode. If system power is provided by, VBUS or the ON/OFF circuitry is in the “ON” state, the MPU core will be placed into standby mode.”</p> <p>In the BRCON description, changed “If BSEL = 1, the baud rate is derived using timer 1.” to “If BSEL = 0, the baud rate is derived using timer 1.”</p> <p>In Section 1.7.15, removed the following from the emulator port description: “The signals of the emulator port have weak pull-ups. Adding resistor footprints for signals E_RST, E_TCLK and E_RXTX on the PCB is recommended. If necessary, adding 10KΩ pull-up resistors on E_TCLK and E_RXTX and a 3KΩ on E_RST will help the emulator operate normally if a problem arises.”</p> <p>In Section 1.7.17.1, added 230000 to the baud rate selections in bullet 7.</p> <p>In the VccCtl description, added “The VDDFLT bit (if enabled) will provide an emergency deactivation of the internal smart card slot. See the VDD Fault Detect Function section for more detail.”</p> <p>Changed last sentence of the DETTS bit description from “TS is decoded prior to the FIFO and is stored in the receive FIFO,” to “TS is decoded before being stored in the receive FIFO.”</p> <p>In Ordering Information, removed the leaded part numbers.</p> |
| 1.2 | 12/16/2008 | <p>In Table 1, added more description to the VCC, VPC, VDD, SCL, SDA, SEC, TEST and PRES pins.</p> <p>In Section 1.3.2, changed “FLSH_ERASE” to “ERASE” and “FLSH_PGADR” to “PGADDR”. Added “The PGADDR register denotes the page address for page erase. The page size is 512 (200h) bytes and there are 128 pages within the flash memory. The PGADDR denotes the upper seven bits of the flash memory address such that bit 7:1 of the PGADDR corresponds to bit 15:9 of the flash memory address. Bit 0 of the PGADDR is not used and is ignored.” In the description of the</p> |

| | |
|--|--|
| | <p>PGADDR register, added “Note: the page address is shifted left by one bit (see detailed description above).”</p> <p>In Table 3, changed “FLSHCRL” to “FLSHCTL”.</p> <p>In Table 5, removed the PREBOOT bit description.</p> <p>In Table 5, moved the TRIMPctl bit description to FUSEctl and moved the FUSEctl bit description to TRIMPctl.</p> <p>In Table 6, changed “PGADR” to “PGADDR”.</p> <p>In Table 7, added PGADDR.</p> <p>In Table 8, changed the reset value for RTCCtl from “0x81” to “0x00”. Added the RTCTrim0 and ACOMP registers. Deleted the OMP, VRctl, LEDCal and LOCKctl registers.</p> <p>In Table 11, removed Mcount entries 7, 8, 9 and 10.</p> <p>In Figure 4, removed CPUCLK.</p> <p>In Table 22, corrected the descriptions for TCON.2 and TCON.0.</p> <p>In the Miscellaneous Control Register 1 (MISCtl1) description, added two paragraphs about MPU clock rates of 12MHz or greater, changing the MPU clock rate or the number of wait states.</p> <p>Changed the register address for ATRMsb from FE21 to FE1F.</p> <p>In Section 1.7.17.5, deleted “The ETU clock is held in reset condition until the activation sequence begins (either by VCCOK=1 or VCCTMR timeout) and will go high ½ the ETU period thereafter.”</p> <p>In Section 1.7.17.5, added “Synchronous card operation is broken down into three primary types. These are commonly referred to as 2-wire, 3-wire and I2C synchronous cards. Each card type requires different control and timing and therefore requires different algorithms to access. Teridian has created an application note to provide detailed algorithms for each card type. Refer to the application note titled <i>73S12xxF Synchronous Card Design Application Note</i>.”</p> <p>In Table 85 and Table 114, changed the SYCKST bit to I2CMODE.</p> <p>Replaced Figure 23, Figure 24, and Figure 25 with new timing diagrams.</p> <p>In Table 114, replaced SYCKST (STXctl, bit 7) with I2CMODE and SCISYN (SPrtcol, bit 7) with I2CMODE.</p> <p>In Figure 27 and Figure 28, replaced the schematics with new schematics.</p> <p>In Section 3.4, changed the Fxtal Min value from 4 to 6.</p> <p>Added Section 6, Related Documentation.</p> <p>Added Section 7, Contact Information.</p> <p>Formatted the document per new standard. Added section numbering.</p> |
|--|--|

© 2008 Teridian Semiconductor Corporation. All rights reserved.
Teridian Semiconductor Corporation is a registered trademark of Teridian Semiconductor Corporation.
Windows is a registered trademark of Microsoft Corporation.
Signum Systems is a trademark of Signum Systems Corporation.
All other trademarks are the property of their respective owners.

Teridian Semiconductor Corporation makes no warranty for the use of its products, other than expressly contained in the Company's warranty detailed in the Teridian Semiconductor Corporation standard Terms and Conditions. The company assumes no responsibility for any errors which may appear in this document, reserves the right to change devices or specifications detailed herein at any time without notice and does not make any commitment to update the information contained herein. Accordingly, the reader is cautioned to verify that this document is current by comparing it to the latest version on <http://www.teridian.com> or by checking with your sales representative.

Teridian Semiconductor Corp., 6440 Oak Canyon, Suite 100, Irvine, CA 92618
TEL (714) 508-8800, FAX (714) 508-8877, <http://www.teridian.com>