



MONOLITHIC IC 82XX SERIES

DESCRIPTION

The normal operation of the UTC **82XX** is that while the power is turned on or interrupted, detect power supply voltage and then reset the system accurately.

The internal circuits of the UTC **82XX** include a built-in fixed delay time generating circuit. With a counter timer using an analog/digital hybrid circuit, the UTC **82XX** as new low reset type system reset ICs expands the delay time series.

These ICs can be used in a variety of CPU systems and other logic systems.

FEATURES

- * Internal Fixed Delay Time Setting by Counter Timer
- * Gate Delay Time Temperature Characteristics: ±800ppm/°C
- * Operating Limit Voltage as 0.65V(Typ.)
- * Hysteresis Voltage Provided: 50mV(Typ.)
- * Circuit Current While On $I_{CCL}=300\mu A$ (Typ.)
- * Circuit Current While Off $I_{CCH}=200\mu A$ (Typ.)

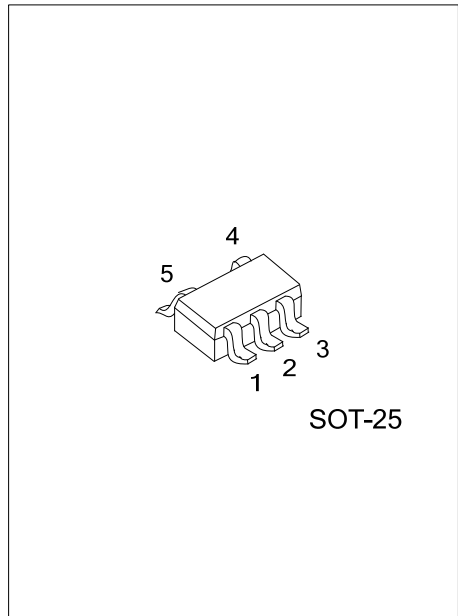

ORDERING INFORMATION

Ordering Number	Package	Packing
82XXG-x-AF5-R	SOT-25	Tape Reel

Notes: xx: Output Voltage, refer to Marking Information.

x : Delay Time, refer to Electrical Characteristics of "H" Transport Delay Time

<p>82XX G-x-AF5-R</p> <ul style="list-style-type: none"> (1) Packing Type (2) Package Type (3) Delay Time (4) Green Package (5) Output Voltage Code 	<ul style="list-style-type: none"> (1) R: Tape Reel (2) AF5: SOT-25 (3) x: Refer to Electrical Charactreistics of "H" Transport Delay Time (4) G: Halogen Free and Lead Free (5) xx: Refer to Marking Information
--	--

MARKING INFORMATION

PACKAGE	VOLTAGE CODE	MARKING
SOT-25	25:2.5V 27:2.7V 2K:2.93V	

PIN CONFIGURATION

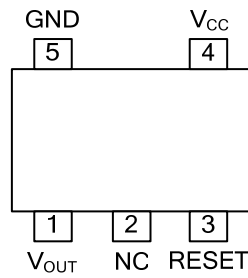

PIN DESCRIPTION

PIN NO.	PIN NAME	DESCRIPTION
1	V _{OUT}	Output pin
2	NC	Connected nothing
3	RESET	Reset control pin
4	V _{CC}	Supply voltage
5	GND	Ground

BLOCK DIAGRAM

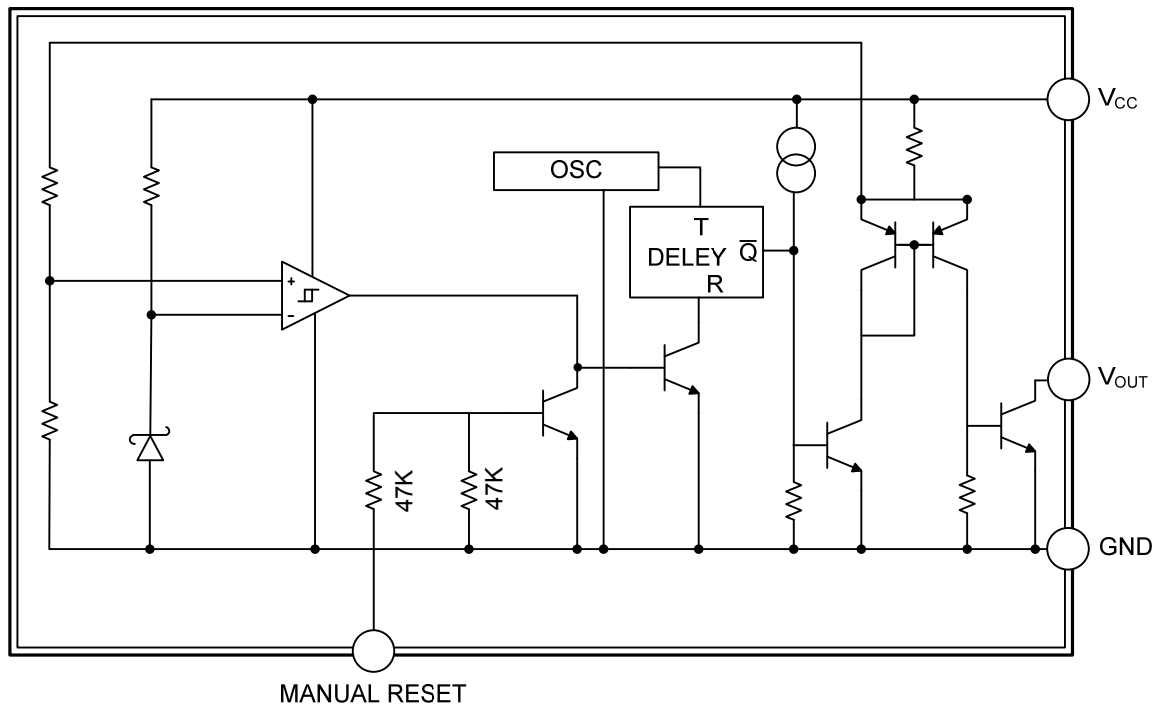

■ ABSOLUTE MAXIMUM RATING (T_A=25°C, Unless otherwise specified)

PARAMETER	SYMBOL	RATINGS	UNIT
Power Supply Voltage	V _{CC}	-0.3~+10	V
Manual Reset Input Voltage	V _{RESET}	-0.3~+10	V
Power Dissipation	P _D	400	mW
Operating Temperature	T _{OPR}	-20~+75	°C
Storage Temperature	T _{STG}	-40~+125	°C

Note: Absolute maximum ratings are those values beyond which the device could be permanently damaged.

Absolute maximum ratings are stress ratings only and functional device operation is not implied.

■ ELECTRICAL CHARACTERISTICS (T_A=25°C, Unless otherwise specified)

V_S=2.5V~2.93V

PARAMETER	SYMBOL	TEST CONDITIONS	MIN	TYP	MAX	UNIT	
Detection Voltage	V _S	V _{OL} ≤0.4V, V _{CC} =H→L, R _L =470Ω (See Test Circuit 1)	V _S -0.15V	V _S	V _S +0.15V	V	
Low-Level Output Voltage	V _{OL}	V _{CC} =V _{S(min)} -0.05V, R _L =470Ω (See Test Circuit 1)		0.1	0.4	V	
Operating Power Supply Voltage	V _{OPL}	R _L =4.7kΩ, V _{OL} ≤0.4V		0.65	0.85	V	
Hysteresis Voltage	ΔV _S	V _{CC} =L→H→L, R _L =470Ω (See Test Circuit 1)	30	50	100	mV	
Detection Voltage Temperature Coefficient	$\frac{V_S}{\Delta T}$	R _L =470Ω, T _A =-20°C~+75°C (See Test Circuit 1)		±0.01		%/°C	
Output Leakage Current	I _{OH}	V _{CC} =10V (See Test Circuit 1)			±0.1	μA	
Circuit Current (See Test Circuit 1)	On	I _{CCL}	V _{CC} =V _{S(MIN)} -0.05V, R _L =∞		300	600	μA
	Off	I _{CCH}	V _{CC} =V _{S(TYP)} /0.85V, R _L =∞		200	350	μA
"H" Transport Delay Time	t _{PLH}	R _L =4.7kΩ, C _L =100PF (Note 1) (See Test Circuit 2)	P	30	50	75	mS
			Q	60	100	150	mS
			R	120	200	300	mS
			S	240	400	600	mS
			T	480	800	1200	mS
"L" Transport Delay Time	t _{PHL}	R _L =4.7kΩ, C _L =100PF (Note 1) (See Test Circuit 2)		10		μS	
Output Current While on 1	I _{OL1}	V _{CC} =V _S min.-0.05V, R _L =0Ω (See Test Circuit 1)	8			mA	
Output Current While on 2	I _{OL2}	T _A =-20°C ~+75°C, R _L =0Ω(Note 2) (See Test Circuit 1)	6			mA	
Manual Reset Pin	Input High Voltage	V _{RESH}	2.0			V	
	Input High Current	I _{RESH}			80	μA	
	Input Low Voltage	V _{RESL}			0.8	V	

Notes: 1. t_{PLH}: V_{CC}=(V_{S(TYP)}-0.4V)→(V_{S(TYP)}+0.4V)

t_{PHL}: V_{CC}=(V_{S(TYP)}+0.4V)→(V_{S(TYP)}-0.4V)

2. V_{CC}=V_{S(MIN)}-0.15V

3. V_{OUT} pin is low when manual reset pin is high.

V_{OUT} pin is high when manual reset pin is low.

■ TEST CIRCUITS

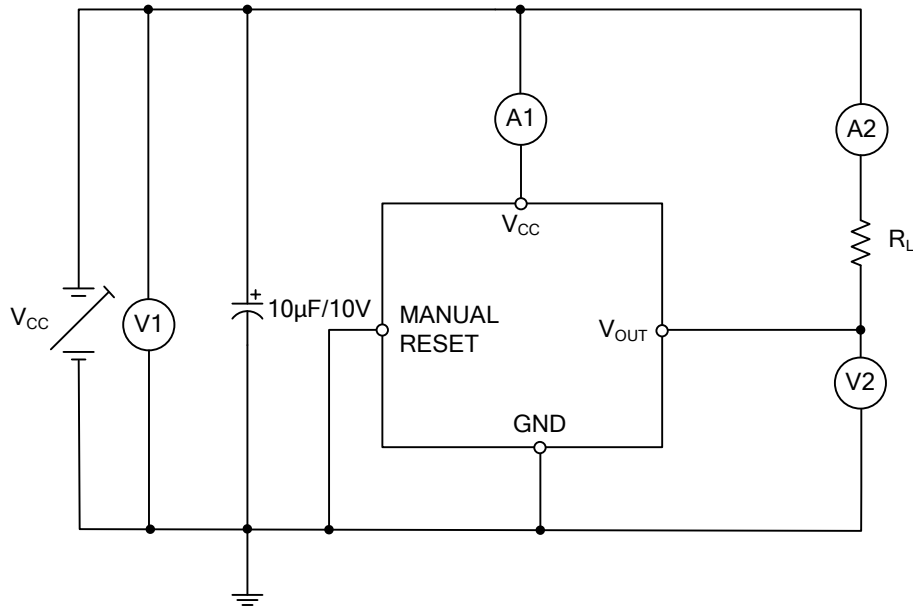

Test Circuit 1

A: DC ammeter
 V: DC voltmeter
 CRT: Oscilloscope

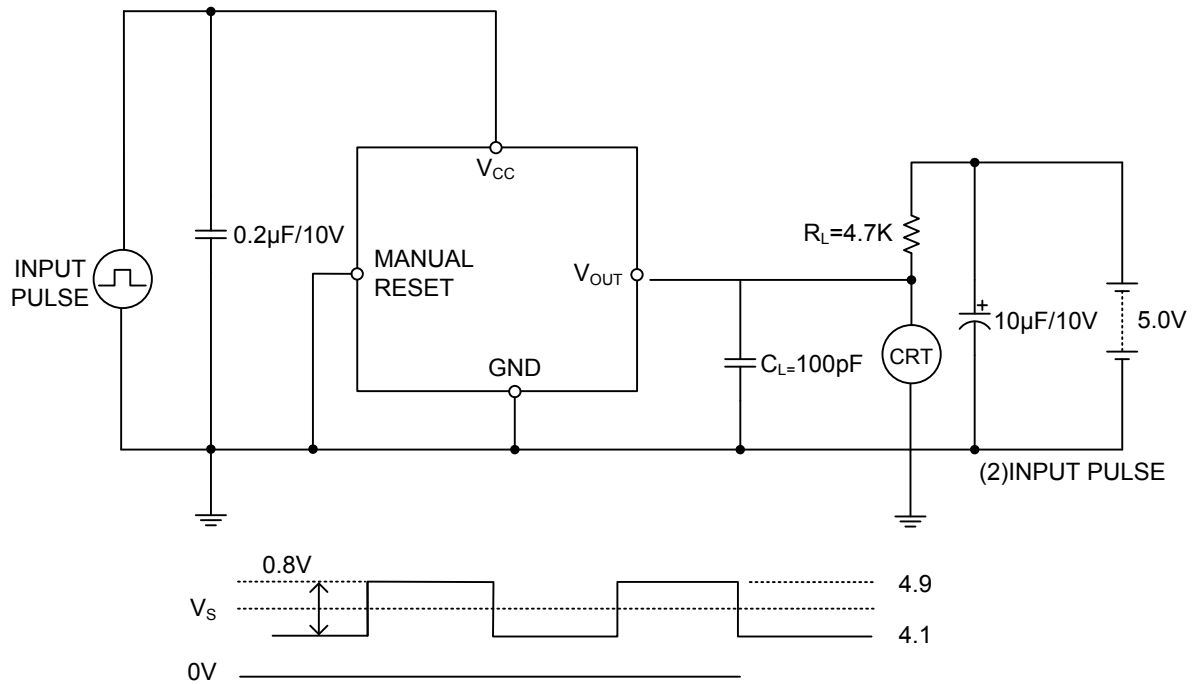

Note Input model is an example for 82XX

Test Circuit 2

■ TIMING CHART

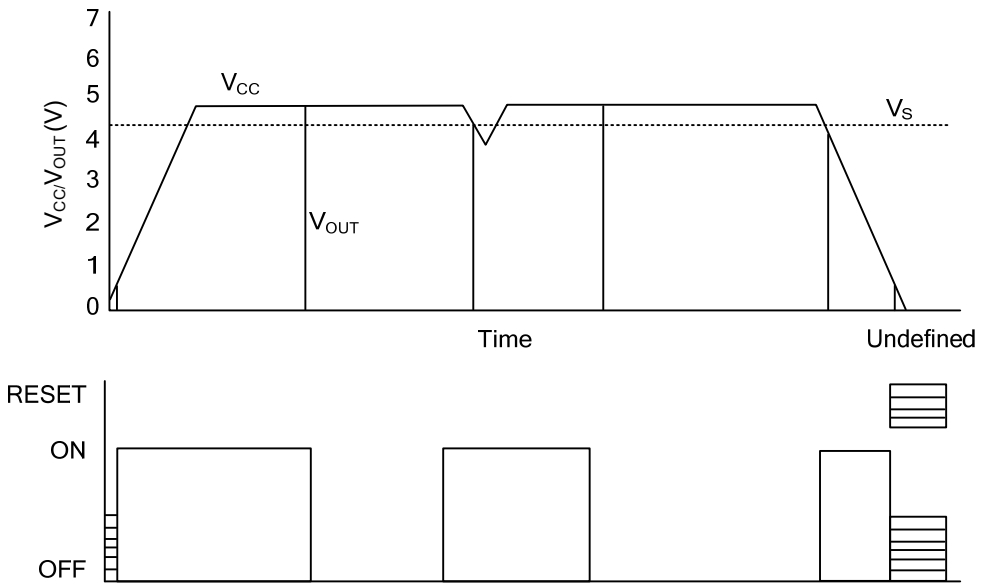

■ TYPICAL APPLICATION CIRCUITS

1. Normal hard reset

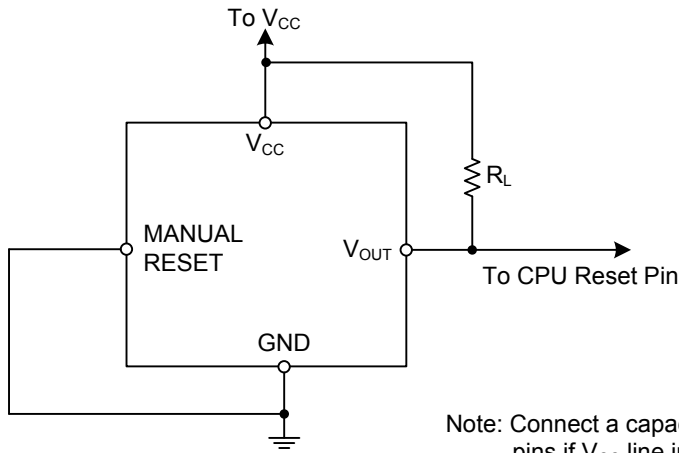

Note: Connect a capacitor between IC V_{CC} and GND pins if V_{CC} line impedance is high.

2. Manual reset

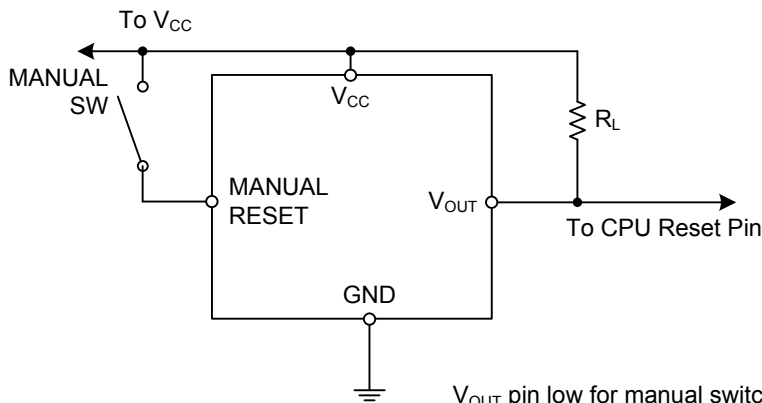

V_{OUT} pin low for manual switch ON.
 V_{OUT} pin high for manual switch OFF.

Note: Connect a capacitor between IC V_{CC} and GND pins if V_{CC} line impedance is high.

3. Mute circuit

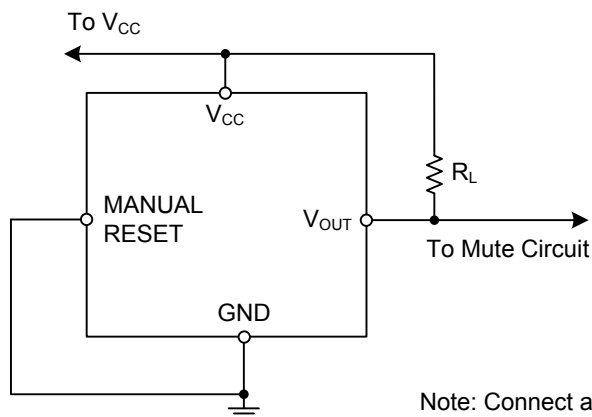

Note: Connect a capacitor between IC V_{CC} and GND pins if V_{CC} line impedance is high.

UTC assumes no responsibility for equipment failures that result from using products at values that exceed, even momentarily, rated values (such as maximum ratings, operating condition ranges, or other parameters) listed in products specifications of any and all UTC products described or contained herein. UTC products are not designed for use in life support appliances, devices or systems where malfunction of these products can be reasonably expected to result in personal injury. Reproduction in whole or in part is prohibited without the prior written consent of the copyright owner. The information presented in this document does not form part of any quotation or contract, is believed to be accurate and reliable and may be changed without notice.