

ohne / without

Mutter / nut  
max. Einschraubtiefe 3.5 mm  
thread depth max. 3.5 mm

Bolzen / bolt  
max. Einschraubtiefe 5.5 mm  
thread depth max. 5.5 mm

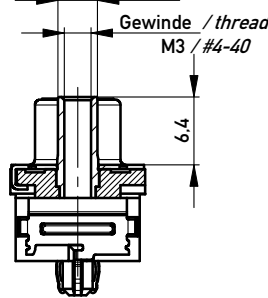
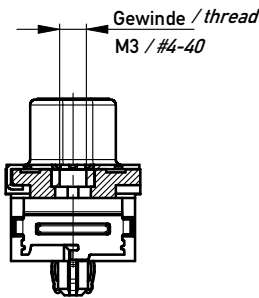
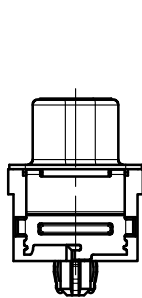

Beschriftung nach Bedruckungsvorschrift 174538  
Part marking according to specification 174538

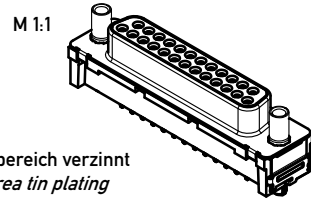

Anschlussbereich verzinkt  
terminal area tin plating

Anforderungsstufe: 2  
class: 2

194927	X			
194931			#4-40	
194930			M3	
194929		#4-40		
194928		M3		
Ident.-Nr. part-no.	ohne without	Mutter thread	Bolzen bolt	Bemerkung remark

Verpackt in Tray  
Verpackungseinheit 30 St.  
tray packaging  
packaging unit 30 pcs

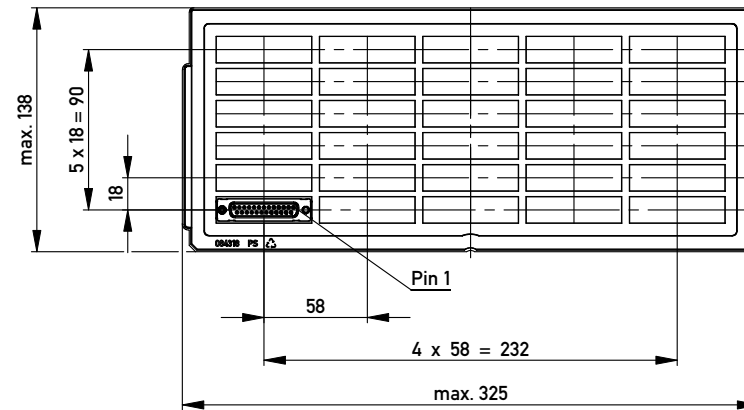

Sonstige Angaben siehe Zeichnung 204628 / Additional indications according to drawing 204628

Layoutvorschlag:  
recommended layout:

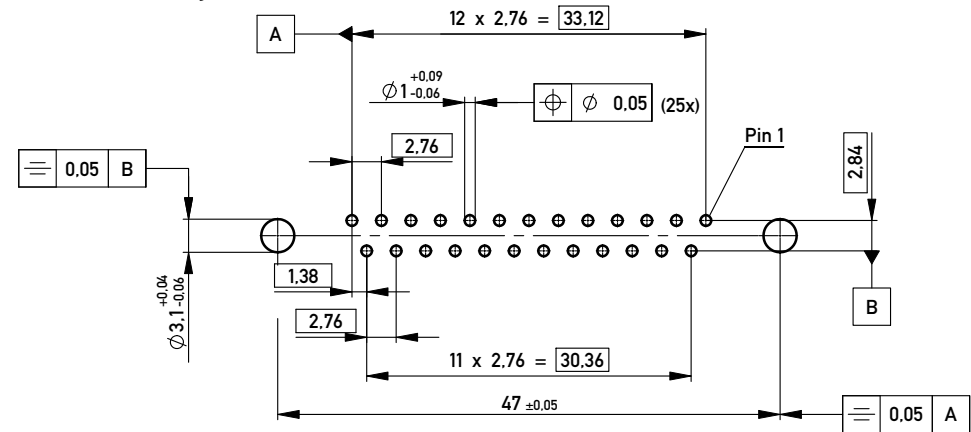

Lochaufbau siehe ERNI-Spezifikation 164062 / hole design according to ERNI-specification 164062

Fehlende Masse und Angaben siehe DIN 41652 / Missing information and dimensions according to DIN 41652  
Sonstige Angaben siehe Fertigungsunterlagen / Additional indications according to the production documentation

Information:  All rights reserved. Only for Information. To ensure that this is the latest version of this drawing, please contact one of the ERNI companies before using.	Tolerances  All Dimensions in mm	Scale 2:1	Designation <b>TMC-S 25-EE-3.0-9.0-BA8</b> <b>TMC-S 25-EE-3.0-9.0-type 8</b>	www.ERNI.com	<b>144941</b>	I <b>A3</b>