



TAI-SAW TECHNOLOGY CO., LTD.

No. 3, Industrial 2nd Rd., Ping-Chen Industrial District,
Taoyuan, 324, Taiwan, R.O.C.

TEL: 886-3-4690038 FAX: 886-3-4697532

E-mail: tstsales@mail.taisaw.com Web: www.taisaw.com

Product Specifications Approval Sheet

Product Description: SAW Filter 915 MHz SMD 1.4X1.1 mm (BW=26MHz)

TST Part No.: TA1423A

Customer Part No.: _____

Customer signature required
Company: _____
Division: _____
Approved by : _____
Date: _____

Checked by: _____ Bob Chau 

Approved by: _____ Bob Chau 

Date: _____ 03/25/2013

1. Customer signed back is required before TST can proceed with sample build and receive orders.
2. Orders received without customer signed back will be regarded as agreement on the specifications.
3. Any specifications changes must be approved upon by both parties and a new revision of specifications shall be released to reflect the changes.



TAI-SAW TECHNOLOGY CO., LTD.

No. 3, Industrial 2nd Rd., Ping-Chen Industrial District,
Taoyuan, 324, Taiwan, R.O.C.

TEL: 886-3-4690038 FAX: 886-3-4697532

E-mail: tstsales@mail.taisaw.com Web: www.taisaw.com

SAW Filter 915MHz

MODEL NO.:TA1423A

REV. NO.:3

A. MAXIMUM RATING:

1. Input Power Level: 10 dBm
2. DC Voltage : 3V
3. Operating Temperature: -40°C to +85°C
4. Storage Temperature: -40°C to +85°C

RoHS Compliant
Lead free
Lead-free soldering

Electrostatic Sensitive Device (ESD)

B. ELECTRICAL CHARACTERISTICS:

Terminating source impedance : $Z_s = 50$

Terminating load impedance : $Z_L = 50$

Item	Unit	Min.	Typ.	Max.	Note
Center Frequency Fc	MHz	-	915	-	-
Insertion Loss (902~928 MHz) IL	dB	-	1.9	2.5	-
Amplitude ripple (902~928 MHz)	dB	-	0.8	1.5	-
VSWR (902~928 MHz)		-	1.6	2	-
Group Delay Deviation (902~928 MHz)	ns	-	11	50	-
Attenuation (reference level from 0 dB)					
10~800 MHz	dB	42	46	-	-
800~845 MHz	dB	40	44	-	-
845~880 MHz	dB	35	38	-	-
947~970 MHz	dB	13	28	-	-
970~1020 MHz	dB	33	47	-	-
1020~1200 MHz	dB	35	43	-	-
1200~3000 MHz	dB	28	34	-	-
Temperature Coefficient of Frequency	ppm/	-	-36	-	-

C.OUTLINE DRAWING:

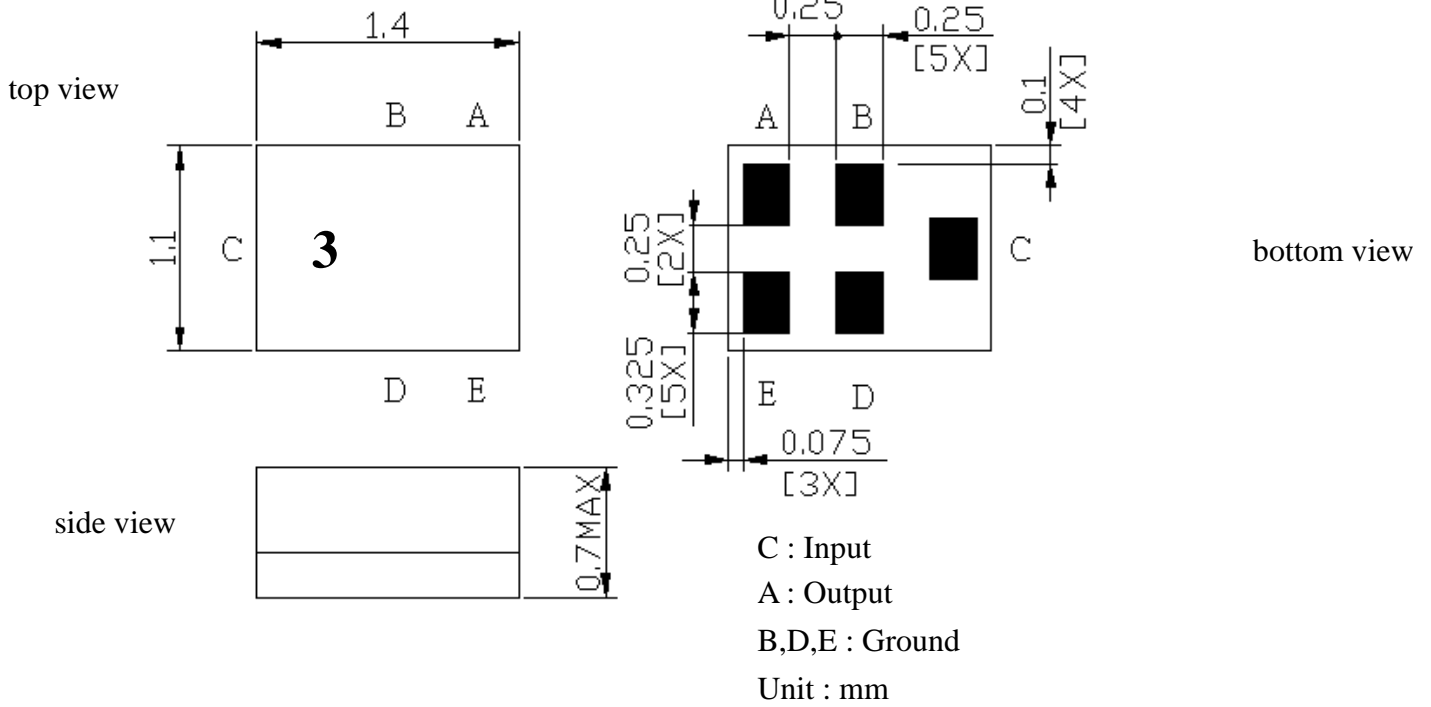

: Year/Month Code (Follow the table)

YEAR/Month	1	2	3	4	5	6	7	8	9	10	11	12
2013	A	B	C	D	E	F	G	H	J	K	L	M
2014	N	P	Q	R	S	T	U	V	W	X	Y	Z
2015	a	b	c	d	e	f	g	h	j	k	l	m
2016	n	p	q	r	s	t	u	v	w	x	y	z
2017	<u>A</u>	<u>B</u>	<u>C</u>	<u>D</u>	<u>E</u>	<u>F</u>	<u>G</u>	<u>H</u>	<u>J</u>	<u>K</u>	<u>L</u>	<u>M</u>
2018	<u>N</u>	<u>P</u>	<u>Q</u>	<u>R</u>	<u>S</u>	<u>T</u>	<u>U</u>	<u>V</u>	<u>W</u>	<u>X</u>	<u>Y</u>	<u>Z</u>
2019	<u>a</u>	<u>b</u>	<u>c</u>	<u>d</u>	<u>e</u>	<u>f</u>	<u>g</u>	<u>h</u>	<u>j</u>	<u>k</u>	<u>l</u>	<u>m</u>
2020	<u>n</u>	<u>p</u>	<u>q</u>	<u>r</u>	<u>s</u>	<u>t</u>	<u>u</u>	<u>v</u>	<u>w</u>	<u>x</u>	<u>y</u>	<u>z</u>

D. MEASUREMENT CIRCUIT:

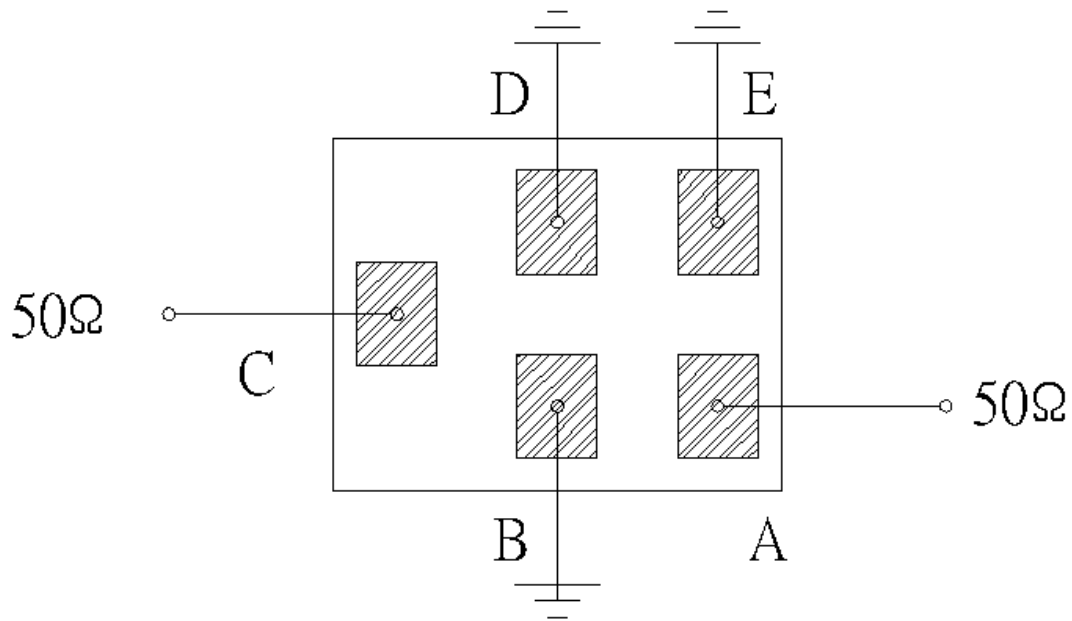

E. PCB Footprint:

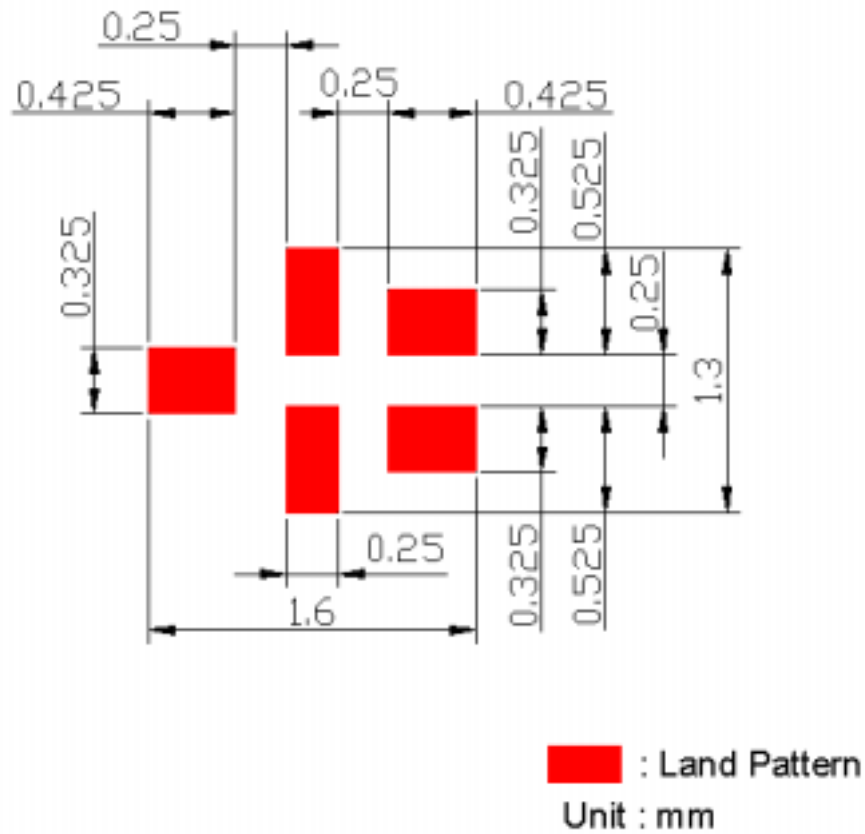

F. Frequency Characteristics :

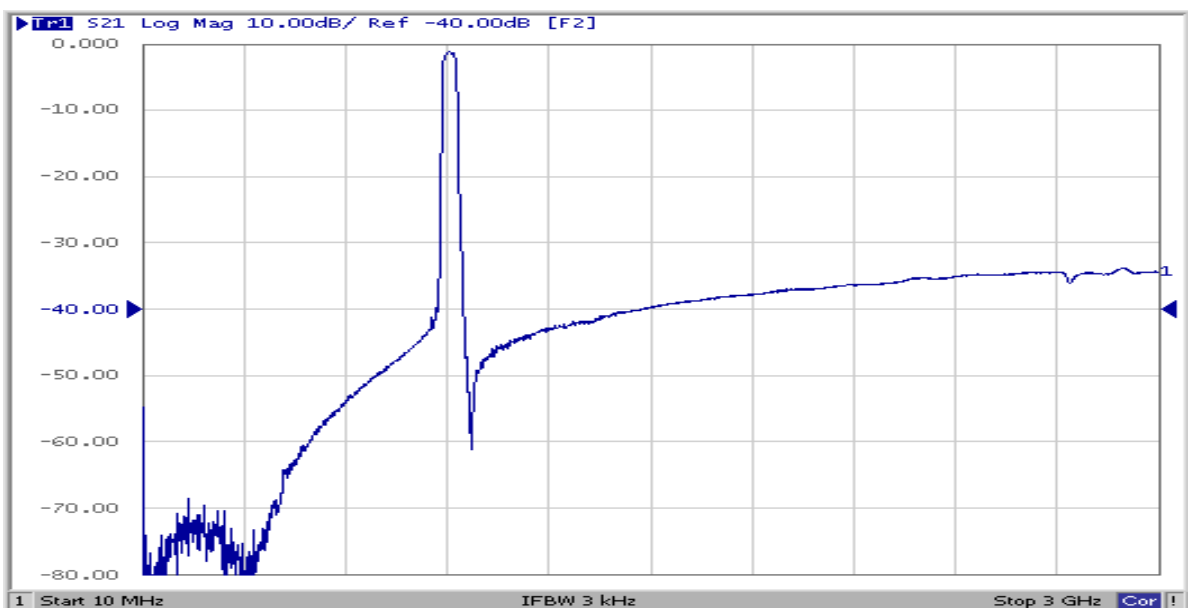
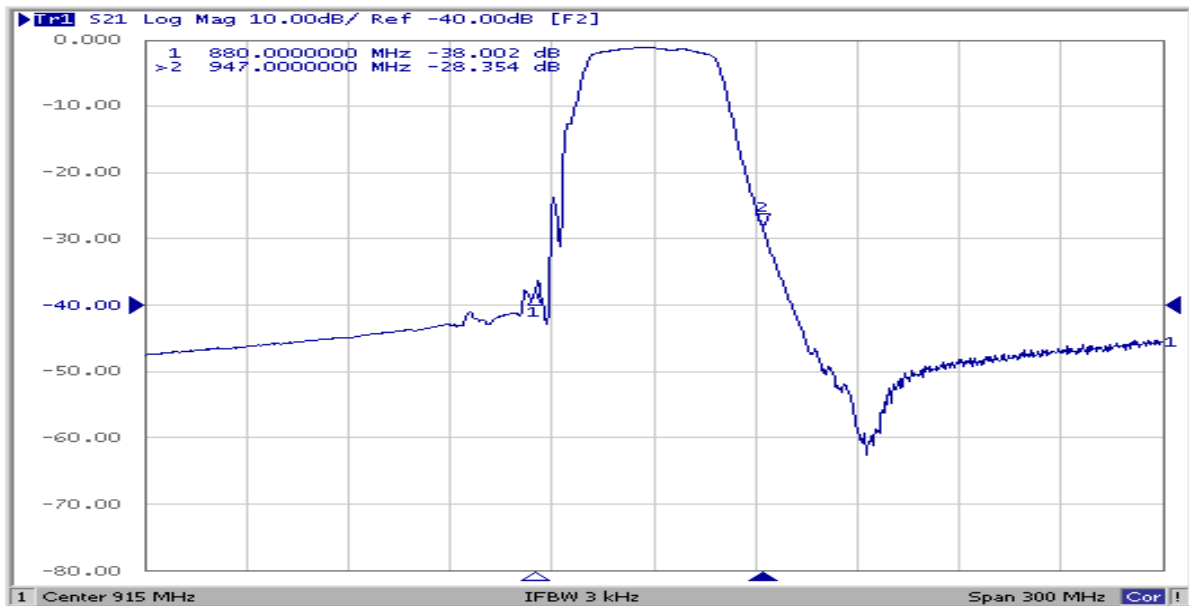
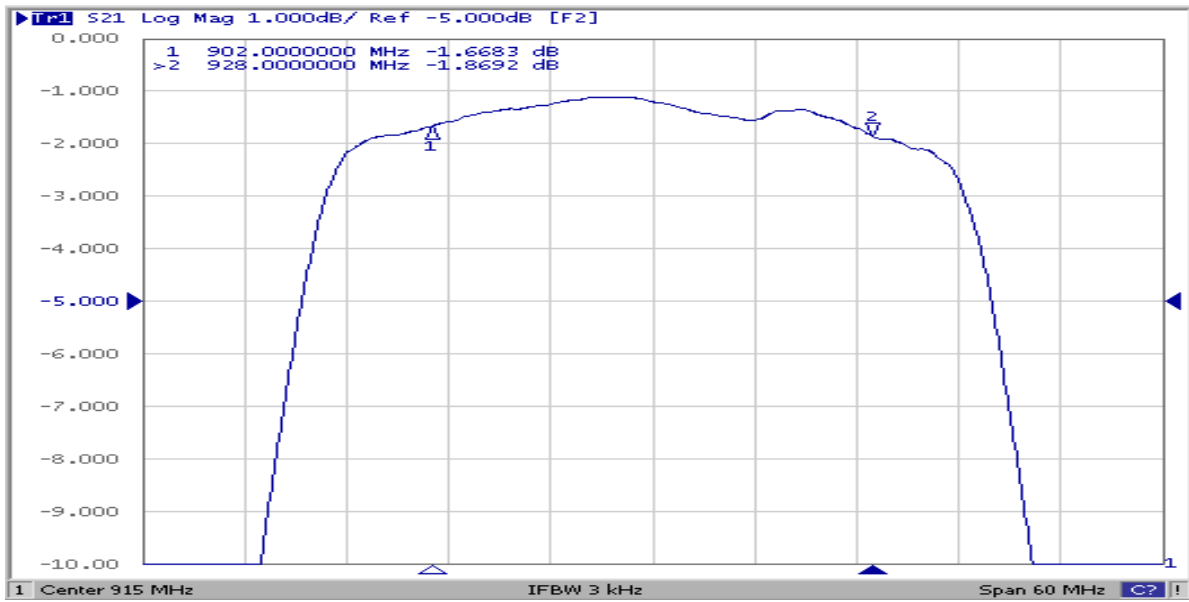

Reflection Functions :

S11

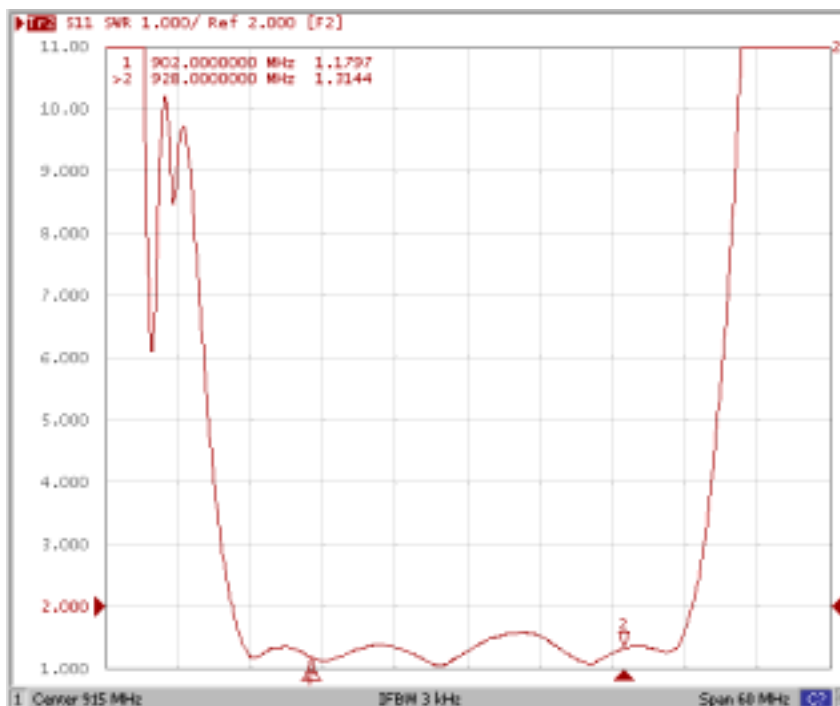

S22

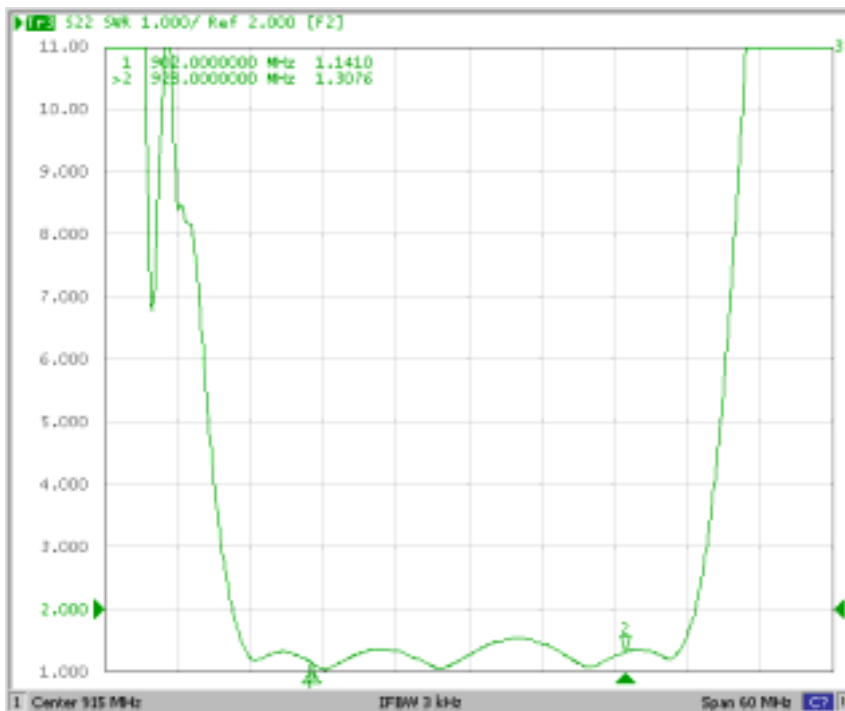

G. PACKING:

1. REEL DIMENSION

(Reel Count : 7"=3000)

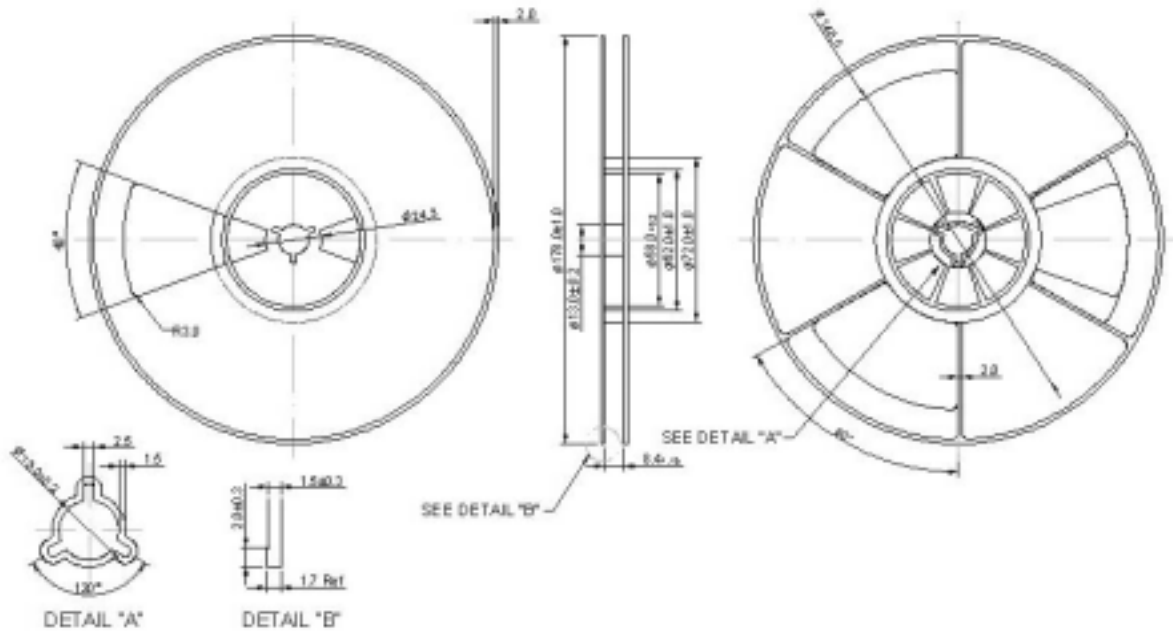

2. TAPE DIMENSION

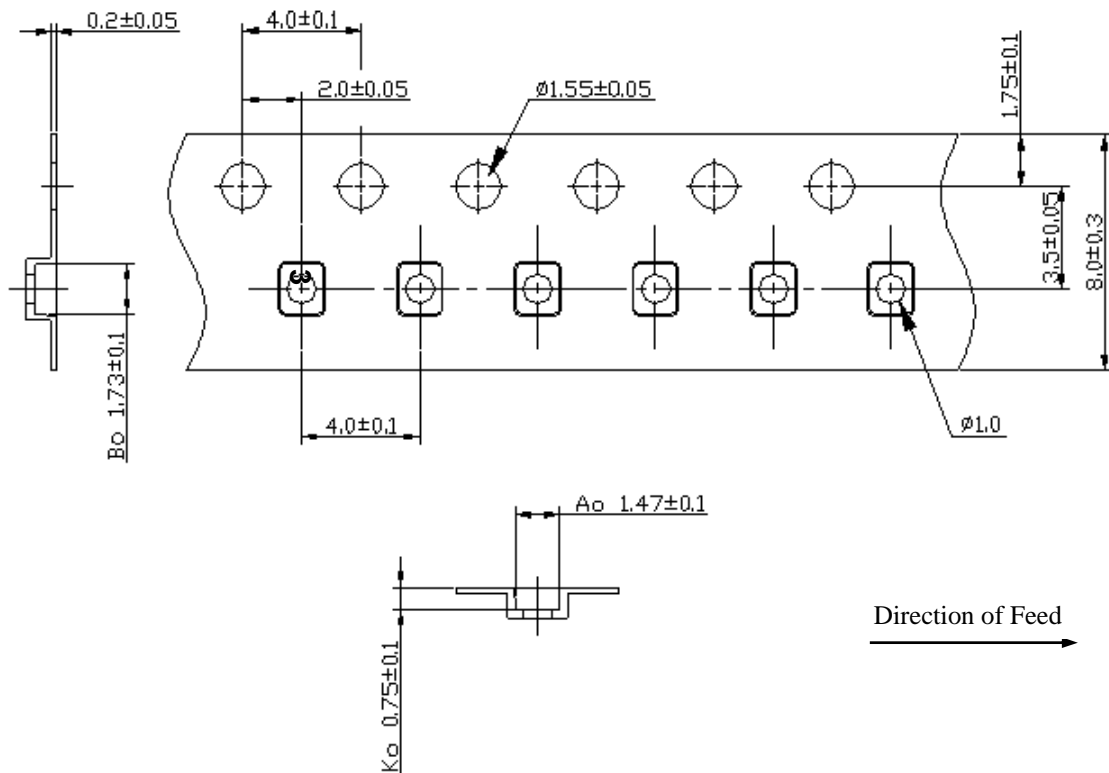

H. RECOMMENDED REFLOW PROFILE :

1. Preheating shall be fixed at 150~180 for 60~90 seconds.
2. Ascending time to preheating temperature 150 shall be 30 seconds min.
3. Heating shall be fixed at 220 for 50~80 seconds and at 245~260 peak (min. 10sec).
4. Time : 2 times.

