

LSI

LSI-6014

5 digit count-down timer

Features

- * 5 digit LCD display
- * Range from 1 – 999minute count down
- * Fixed time duration by bonding option
- * Easy to use and control
- * Direct drive 1/2 bias 1/3 duty LCD
- * Very low power consumption
- * 32768 Crystal oscillator
- * Single 1.5V operation.

General Description

The LSI6014 is a universal count down timer with 5 digit display, MMM:SS. The maximum minute range is from 0-999 minutes. It can also be programmed in fixed timer mode in which many fixed duration has already been programmed into the LSI6014 and the user can select the timer range by bonding option.

The LSI6014 directly drive a 1/2 duty 1/3 bias LCD. It has a very low current consumption and is suitable for timer application.

Functional Description

Power up

At power up, the LSI6014 turns on all LCD and output 3 beep sounds and then display the selected time range by bonding option.

Key operation

The LSI6014 has five key operation M100, M10, M1, START and RESET keys.

For ease of operation, the final product can have 2 to 5 key operation depending on the usage.

Keys	Description	Setting Range
START, RESET	2 key fixed time (bonding option) count down timer	
START, RESET, M1	3 key count down timer with/without preset value by bonding option.	1 – 9 minutes (step 1 minute)
START, RESET, M1,M10	4 key count down timer with/without preset value by bonding option.	1 – 99 minutes (step 1 minute)
START, RESET, M1,M10,M100	5 key count down timer with/without preset value by bonding option.	1 – 999 minutes (step 1 minute)

Press M100/M10/M1 adds 100/10/1 to the setting value.

After the setting is finished, press START starts the countdown timer.

By the end of count down, the system output 10 beep sounds and then display the selected duration selected by bonding option.

The bonding option OPT[0:4] is used to set the default value. The bonding option default value is shown in the following table.

OPT0	OPT1	OPT2	OPT3	OPT4	MUNUTES	OPT0	OPT1	OPT2	OPT3	OPT4	MUNUTES
V	V	V	V	V	0	G	V	V	V	V	X
V	G	V	V	V	1	G	G	V	V	V	20
V	V	G	V	V	2	G	V	G	V	V	25
V	G	G	V	V	3	G	G	G	V	V	30
V	V	V	G	V	4	G	V	V	G	V	35
V	G	V	G	V	5	G	G	V	G	V	40
V	V	G	G	V	6	G	V	G	G	V	45
V	G	G	G	V	7	G	G	G	G	V	50
V	V	V	V	G	8	G	V	V	V	G	55
V	G	V	V	G	9	G	G	V	V	G	60
V	V	G	V	G	10	G	V	G	V	G	75
V	G	G	V	G	11	G	G	G	V	G	90
V	V	V	G	G	12	G	V	V	G	G	105
V	G	V	G	G	13	G	G	V	G	G	120
V	V	G	G	G	14	G	V	G	G	G	150
V	G	G	G	G	15	G	G	G	G	G	180

Note : V - Connected to VDD, G - Connected to GND.

Pin Assignment

DESIGNATION	TYPE	DESCRIPTION
BD [0:1]	OUTPUT	Buzzer output
F512, VCAP	OUTPUT	Doubler output
VEE	OUTPUT	-1.5V
T1, T2, T3	INPUT	TEST pin
COSCO	OUTPUT	32KHz oscillator output
COSCI	INPUT	32KHz oscillator input
VDD	POWER	+1.5V power supply
GND	POWER	Ground
M100/M10/M1	INPUT(PH)	Input key
OPT[0:4]	INPUT(PH)	Bonding option
START/RESET	INPUT(PH)	Input key
C[1:3]	OUTPUT	LCD Common output
S[1:16]	OUTPUT	LCD Segment output

Note: (PH) - pull high; (OD)-open drain

Absolute Maximum Ratings

Supply voltage Vdd - Vss.....0 to 5V
 Input voltage Vin.....Vss to Vdd
 Operating temperature Top-10°C to 60°C
 Storing temperature Tst-40°C to 70°C

Comments

Stress above those listed under “absolute Maximum Ratings” may cause permanent damage to the device. These are stress rating only. Functional operation of this device at these or any other conditions above those indicated in the operational sections of this specification is not implied and exposure to absolute maximum rating conditions for extended periods may affect device reliability.

D.C. Electrical Characteristics

(GND = 0V, Vdd = 1.5V, Ta = 25°C unless otherwise specified)

Parameter	Symbol	Min.	Typ.	Max.	Unit	Conditions
Supply Voltage	Vdd	1.2	1.5	1.8	V	
Operating current	Idd	-	2	6	μA	No load
OSC. built-in cap	Cd	-	20	-	pF	
OSC. trimmer cap	Ctrim	5	-	35	pF	
Frequency stability	$\Delta f/f$	-	-	10	ppM	Vdd=1.6-1.4
Buzzer output current	Ibd	500	-	-	μA	Vbd-Vss=0.5
LCD frequency	Flcd	-	64	-	Hz	
Segment current	Ilcd	0.15	-	-	μA	Vseg=0.2V
Common current	Icom	3.0	-	-	μA	Vcom=0.2V

Pad Coordinate

PAD	X(μm)	Y(μm)	PAD	X(μm)	Y(μm)
GND	-1295.0	-1394.0	PB	-743.0	+1350.0
VCAP	-1295.0	-1251.0	R2	-593.0	+1350.0
VEE	-1295.0	-1110.0	R1	-449.0	+1350.0
V512	-1295.0	-965.0	R0	-225.0	+1350.0
C3	-1295.0	-825.0	OSCO	-75.0	+1350.0
C2	-1295.0	-685.0	OSCI	+1105.0	+1340.0
C1	-1295.0	-545.0	T1	+1246.0	+1340.0
S1	-1295.0	-400.0	GND	+1246.0	+1140.0
S2	-1295.0	-260.0	B1	+1246.0	+988.0
S3	-1295.0	-120.0	B0	+1246.0	+678.0
S4	-1295.0	+20.0	VDD	+1246.0	+543.0
S5	-1295.0	+160.0	T2	+1246.0	+395.0
S6	-1295.0	+300.0	X1	+1246.0	+226.0
S7	-1295.0	+440.0	M100	+1246.0	+78.0
S8	-1295.0	+580.0	M10	+1246.0	-70.0
S9	-1295.0	+720.0	M1	+1246.0	-216.0
S10	-1295.0	+860.0	OPT0	+1246.0	-365.0
S11	-1295.0	+1000.0	T3	+1246.0	-513.0
S12	-1295.0	+1140.0	START	+1246.0	-661.0
S13	-1303.0	+1350.0	RESET	+1246.0	-809.0
S14	-1163.0	+1350.0	OPT1	+1246.0	-957.0
S15	-1023.0	+1350.0	OPT2	+1246.0	-1105.0
S16	-883.0	+1350.0	OPT3	+1246.0	-1253.0
			OPT4	+1246.0	-1400.0

Pad Location

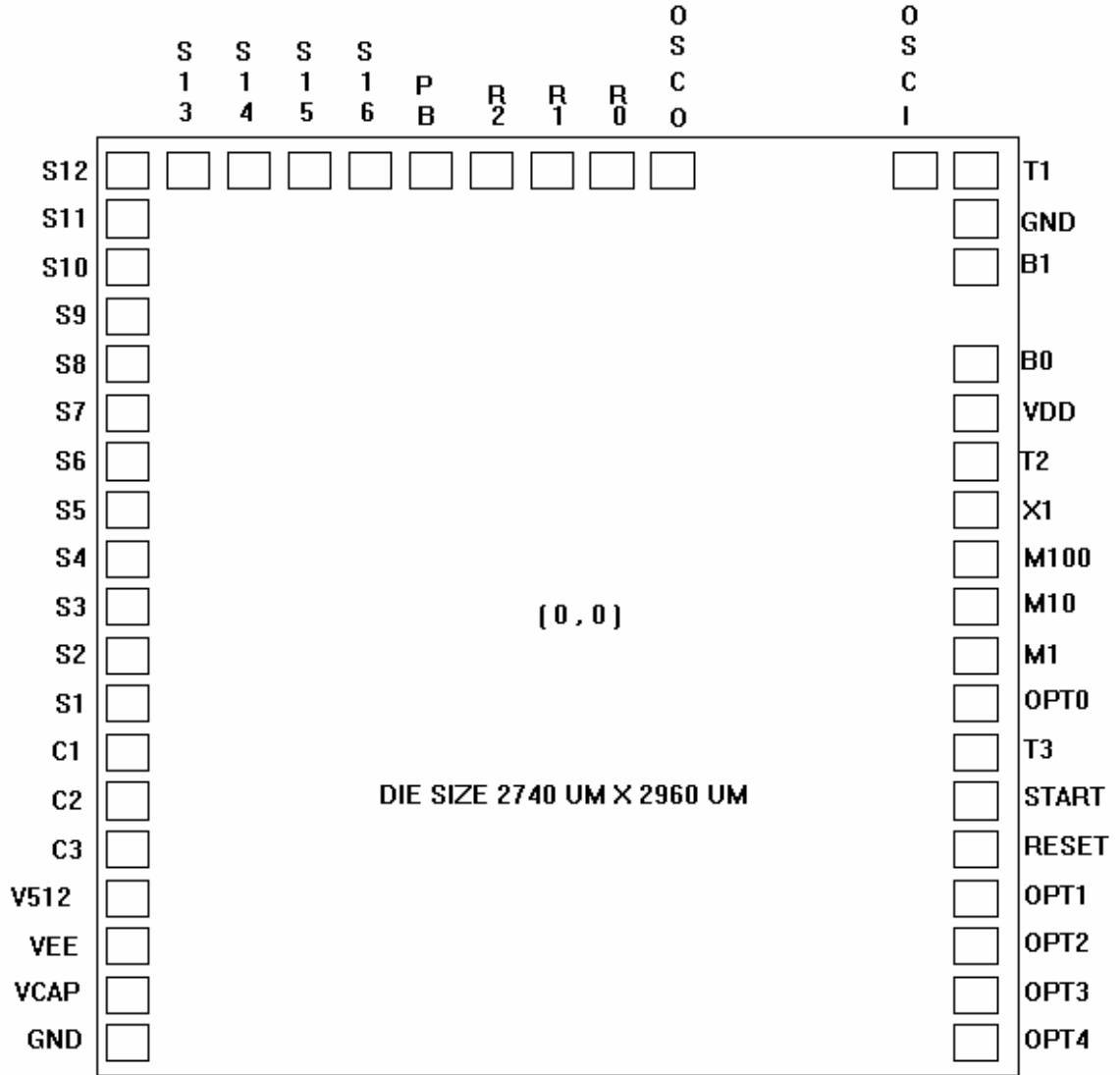

Application Circuit

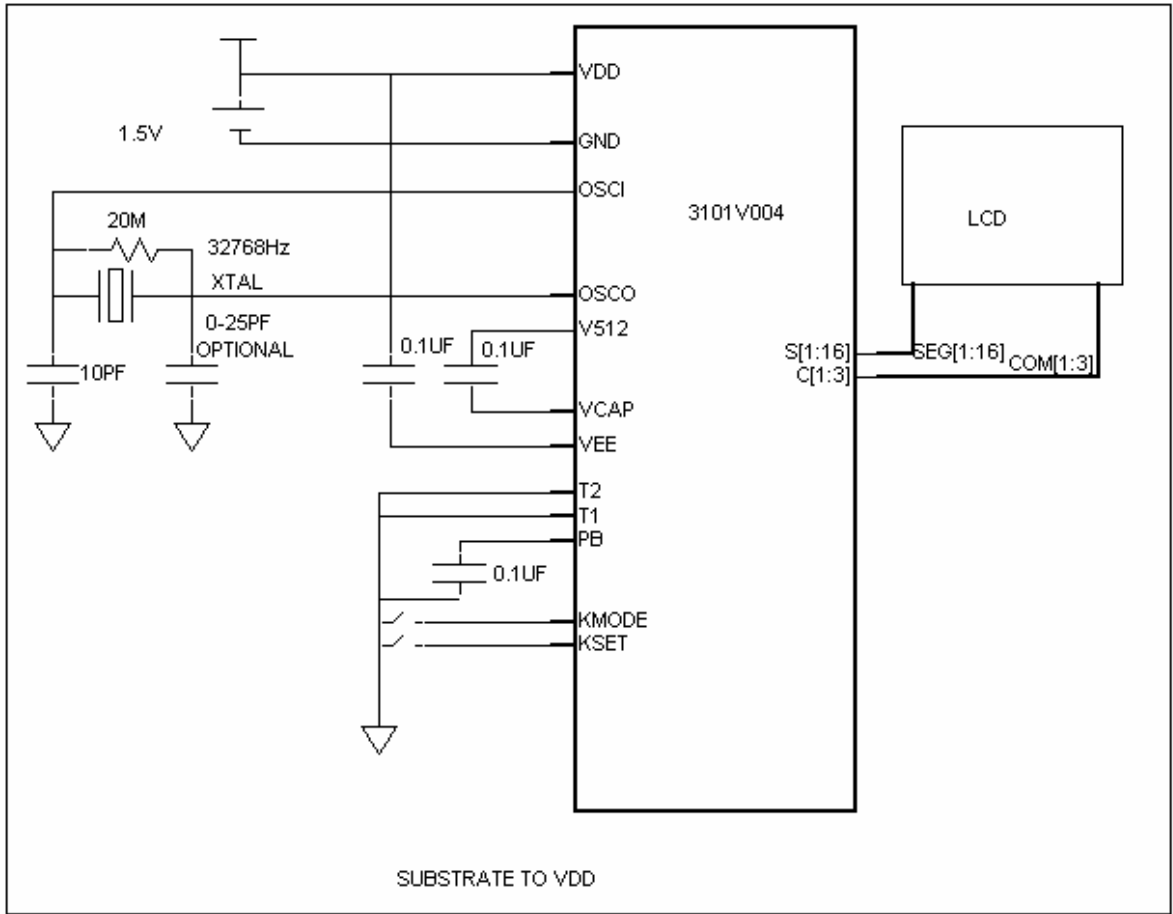

Lcd pinout

PIN1

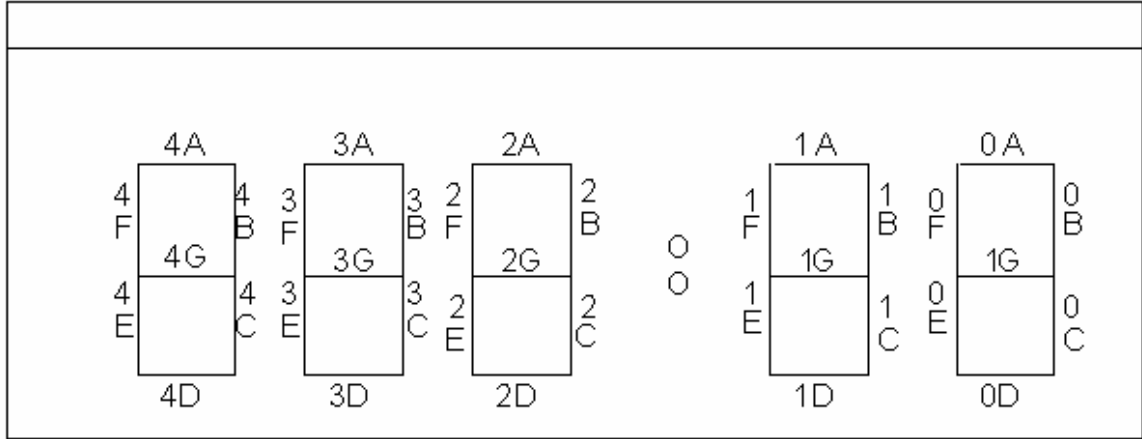

LCD table

PIN	1	2	3	4	5	6	7	8	9	10	11	12	13	14	15	16	17	18	19
NAME	C3	C2	C1	S1	S2	S3	S4	S5	S6	S7	S8	S9	S10	S11	S12	S13	S14	S15	S16
C1	/	/	C1	F4	A4	B4	/	F3	A3	B3	/	F2	A2	B2	/	F1	A1	B1	/
C2	/	C2	/	E4	G4	C4	/	E3	G3	C3	/	E2	G2	C2	:	E1	G1	C1	/
C3	C3	/	/	D4	/	/	/	D3	/	A0	/	D2	B0	G0	C0	D1	D0	E0	F0