

## Bluetooth® 4.2 Dual-Mode Module

### Features

- Bluetooth Classic (BR/EDR) and Low Energy (LE)
- Certified to FCC, IC, MIC, KCC, and NCC radio regulations
- European R&TTE Directive Assessed Radio module
- Bluetooth SIG 4.2 qualified
- Transparent UART mode for seamless serial data over UART interface
- Easy to configure with User Interface (UI) tool, a Windows® configuration utility or directly by MCUs
- Firmware can be upgraded in the field over UART (Flash version)
- Integral chip antenna (BM78SPPS5MC2/NC2) or external antenna (BM78SPP05MC2/NC2)
- Integrated crystal, internal voltage regulator, and matching circuitry
- Configurable I/O pins for control and status
- Supports Apple® iPod Accessory Protocol (iAP2), (only BM78SPPx5MC2)
- Supports Bluetooth 4.2 LE secure connections
- Bluetooth 4.2 LE data packet length extension
- Small and compact surface mount module
- Castellated SMT pads for easy and reliable PCB mounting
- Ideal for portable battery operated devices
- One LED driver with 16 steps brightness control

### RF/Analog

- Frequency: 2.402 GHz to 2.480 GHz
- Receive Sensitivity: -90 dBm (BR/EDR), -92 dBm (LE)
- Class 2 output power (+1.5 dBm typical)

### Data Throughput

Data Throughput at 1 Mbps UART baud rate:

- BR/EDR: up to 32 Kbps
- LE: up to 7 Kbps

Data Throughput at 115200 bps UART baud rate

- BR/EDR: upto 10 Kbps
- LE: up to 6 Kbps



### MAC/Baseband/Higher Layer

- Secure AES128 encryption
- Bluetooth 3.0: GAP, SPP, SDP, RFCOMM, and L2CAP
- Bluetooth 4.2: GAP, GATT, ATT, SMP, and L2CAP

### Operating Conditions

- Operating voltage range: 3.3V to 4.2V
- Operating temperature: -20°C to +70°C

### Applications

- Internet of Things (IoT)
- Secure Payment
- Home and Security
- Health and Fitness
- Industrial and Data Logger
- LED Lighting (16 configurations)

# BM78

---

## General Description

The BM78 module is a fully-certified, Bluetooth version 4.2 module for customers to easily add dual-mode Bluetooth wireless capability to their products. The BM78 is built around Microchip's IS1678 Bluetooth dual-mode module, and it is available in ROM-based (BM78SPPx5NC2) and Flash-based (BM78SPPx-5MC2) versions. Refer to [Section 9.0 “Ordering Information”](#) for additional information on the BM78 SKUs.

The BM78 bridges the customer products to smart phones or tablets for convenient data transfer, control, and access to cloud applications delivering local connectivity for IoT. The BM78 supports GAP, SDP, SPP, and GATT profiles. Data transfer is achieved through the Bluetooth link by sending or receiving data through transparent UART mode, making it easy to integrate with any microprocessor or Microcontroller (MCU) with a UART interface. It also enables a easy configuration by using a UI tool, a Windows configuration utility, or directly through UART by MCUs.

## Table of Contents

1.0 System Overview .....	5
2.0 Application Information .....	11
3.0 Operating Pattern .....	23
4.0 Electrical Characteristics .....	31
5.0 Radio Characteristics .....	35
6.0 Physical Dimensions .....	37
7.0 Reflow profile .....	43
8.0 Module Placement .....	45
9.0 Ordering Information .....	49
Appendix A: Certification Notices .....	51

### TO OUR VALUED CUSTOMERS

It is our intention to provide our valued customers with the best documentation possible to ensure successful use of your Microchip products. To this end, we will continue to improve our publications to better suit your needs. Our publications will be refined and enhanced as new volumes and updates are introduced.

If you have any questions or comments regarding this publication, please contact the Marketing Communications Department via E-mail at [docerrors@microchip.com](mailto:docerrors@microchip.com) or fax the **Reader Response Form** in the back of this data sheet to (480) 792-4150. We welcome your feedback.

#### Most Current Data Sheet

To obtain the most up-to-date version of this data sheet, please register at our Worldwide Web site at:

<http://www.microchip.com>

You can determine the version of a data sheet by examining its literature number found on the bottom outside corner of any page. The last character of the literature number is the version number, (e.g., DS30000000A is version A of document DS30000000).

#### Errata

An errata sheet, describing minor operational differences from the data sheet and recommended workarounds, may exist for current devices. As device/documentation issues become known to us, we will publish an errata sheet. The errata will specify the revision of silicon and revision of document to which it applies.

To determine if an errata sheet exists for a particular device, please check with one of the following:

- Microchip's Worldwide Web site; <http://www.microchip.com>
- Your local Microchip sales office (see last page)

When contacting a sales office, please specify which device, revision of silicon and data sheet (include literature number) you are using.

#### Customer Notification System

Register on our web site at [www.microchip.com](http://www.microchip.com) to receive the most current information on all of our products.

# BM78

---

NOTES:

## 1.0 SYSTEM OVERVIEW

The BM78 module is a fully certified, embedded 2.4 GHz Bluetooth version 4.2 (BR/EDR/LE) wireless module. It includes an on board Bluetooth stack, a power management subsystem, a 2.4 GHz transceiver, and an RF power amplifier. Customers can embed Bluetooth functionality into any applications using the BM78.

The BM78 enables rapid product development and faster time to market, and it is designed to provide integrators with the following features:

- Simple integration and programming
- Reduced development time
- Superior wireless module with low-cost system
- Interoperability with Bluetooth host
- Wide range of applications

The BM78 has four Stock Keeping Units (SKUs). For additional information on SKUs, refer to [Section 9.0 “Ordering Information”](#). The BM78SPPS5MC2/NC2 is a complete and fully regulatory certified module with an integral ceramic chip antenna and RF shield. The BM78SPP05MC2/NC2 is a low-cost alternative with RF out PAD (for external antenna) and no RF shield. The integrator is responsible for the antenna, antenna matching, and regulatory certifications.

The BM78 is a small, compact, and surface mounted module with castellated pads for easy and reliable host PCB mounting. It is compatible with standard pick-and-place equipment and can independently maintain a low-power wireless connection. Low power usage and flexible power management maximize the lifetime of the BM78 in battery-operated devices. A wide operating temperature range enables its applications in indoor and outdoor environments. [Figure 1-1](#) illustrates the internal block diagram of the BM78.

**FIGURE 1-1: INTERNAL BLOCK DIAGRAM OF BM78**

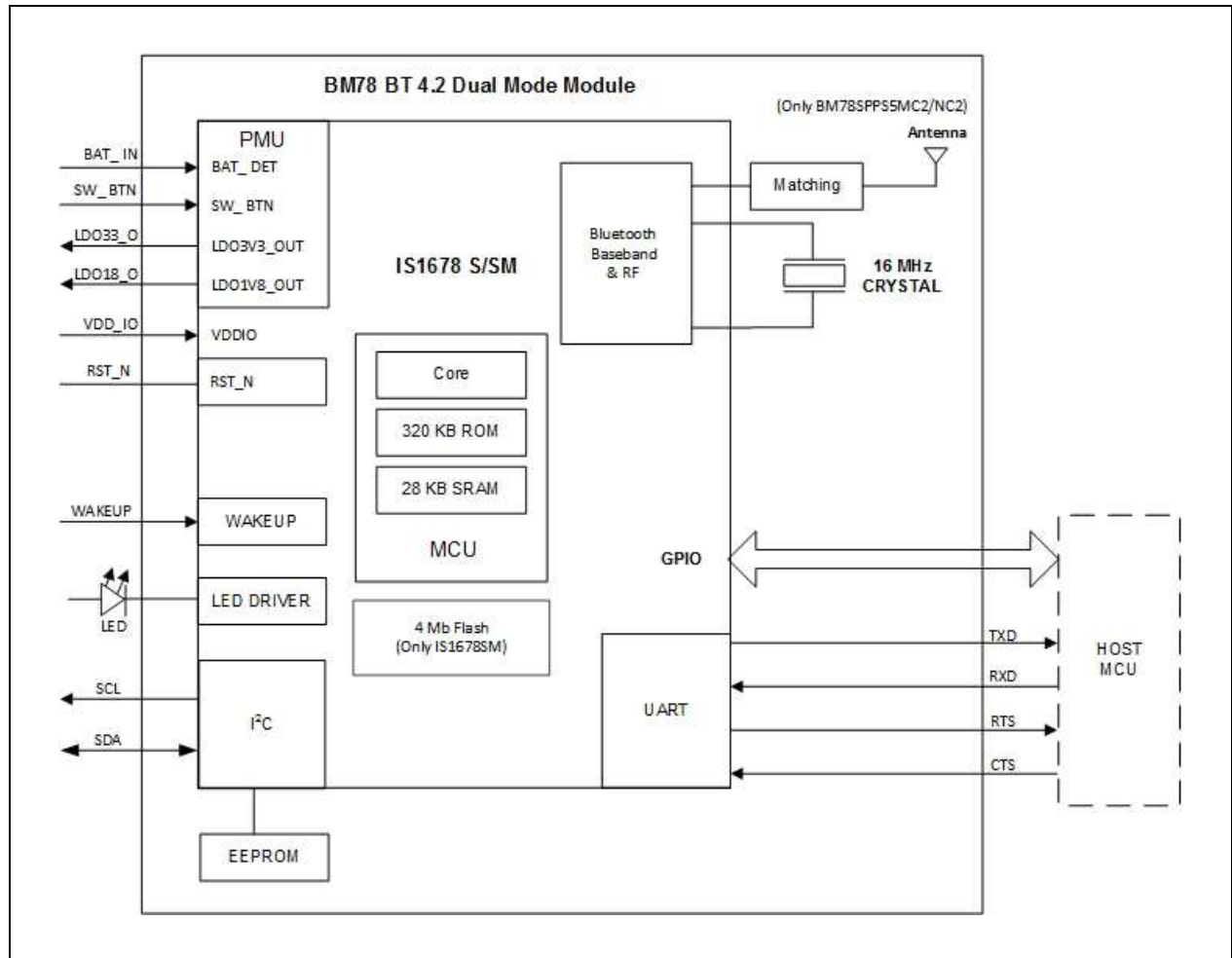

# BM78

Table 1-1 provides various pins of the BM78SPPx5MC2/NC2 module.

**TABLE 1-1: PIN DESCRIPTION**

S5 Pin	O5 Pin	Symbol	Type	Description
1	—	GND	Power	Ground reference
2	—	GND	Power	Ground reference
3	1	GND	Power	Ground reference
4	2	BAT_IN	Power	Battery Input (3.3V to 4.2V) Main positive supply input Connect to 10 uF (X5R/X7R) capacitor
5	3	SW_BTN	DI	Software Button H: Power On L: Power Off
6	4	LDO33_O	Power	Internal 3.3V LDO output, can source no more than 50 mA
7	5	VDD_IO	Power	I/O positive supply input. Internal use only, do not connect to other devices
8	6	LDO18_O	Power	Internal 1.8V LDO output. Internal use only, do not connect to other devices
9	7	WAKEUP	DI	Wakeup from Sleep mode (active- low) (internal pull-up)
10	8	PMULDO_O	Power	Power management unit output. Internal use only, do not connect to other devices
11	9	P0_4	DO	Status Indication pin along with P1_5, refer to <a href="#">Table 2-3</a>
12	10	P1_5	DO	Status Indication pin along with P0_4, refer to <a href="#">Table 2-3</a>
13	11	P1_2/SCL	DO	I <sup>2</sup> C SCL
14	12	P1_3/SDA	DIO	I <sup>2</sup> C SDA
15	13	P1_7/CTS	DIO	Configurable Control or Indication pin or UART CTS (input)
16	14	P0_5	DIO	Configurable Control or Indication pin
17	15	P0_0/RTS	DIO	Configurable Control or Indication pin or UART RTS (output)
18	16	P2_0	DI	System configuration pin along with P2_4 and EAN pins, used to set the BM78 in any one of the following three modes: Application mode (for normal operation), Test mode (to change EEPROM values), and Write Flash mode (to enter the new firmware into the module), refer to <a href="#">Table 2-1</a>
19	17	P2_4	DI	System configuration pin along with P2_0 and EAN pins, used to set the module in any one of the following three modes: Application mode (for normal operation), Test mode (to change EEPROM values), and Write Flash mode (to enter new firmware into the module), refer to <a href="#">Table 2-1</a>

**Legend:** A = Analog    D = Digital    I = Input    O = Output

**TABLE 1-1: PIN DESCRIPTION (CONTINUED)**

S5 Pin	05 Pin	Symbol	Type	Description
20	18	EAN	DI	External address-bus negative System configuration pin along with P2_0 and P2_4 pins, used to set the module in any of the three modes: Application mode (for normal operation), Test mode (to change EEPROM values), and Write Flash mode (to enter new firmware into the module), refer to <a href="#">Table 2-1</a> ROM: Must be pulled high to VDD_IO FLASH: Must be pulled down with 4.7Kohm to GND
21	19	RST_N	DI	Module Reset (active-low) (internal pull up) Apply a pulse of at least 63 ns
22	20	RXD	DI	UART data input
23	21	TXD	DO	UART data output
24	22	P3_1	DIO	Configurable Control or Indication pin (Internally pulled-up, if configured as an input)
25	23	P3_2	DIO	Configurable Control or Indication pin (Internally pulled-up, if configured as an input)
26	24	P3_3	DIO	Configurable Control or Indication pin (Internally pulled-up, if configured as an input)
27	25	P3_4	DIO	Configurable Control or Indication pin (Internally pulled-up, if configured as an input)
28	26	P3_6	DIO	Do not connect
29	27	P3_7	DIO	Configurable Control or Indication pin (Internally pulled-up, if configured as an input)
30	28	LED1	DO	Status LED, connect to LDO33_0
31	29	GND	Power	Ground reference
—	30	BT_RF	AIO	External antenna connection(50 ohms)
32	—	GND	Power	Ground reference

**Legend:**      A = Analog      D = Digital      I = Input      O = Output

# BM78

Figure 1-2 and Figure 1-3 illustrate the pin diagrams of the BM78SPPS5MC2/NC2 and BM78SPP05MC2/NC2 modules.

**FIGURE 1-2: BM78SPPS5MC2/NC2 PIN DIAGRAM**

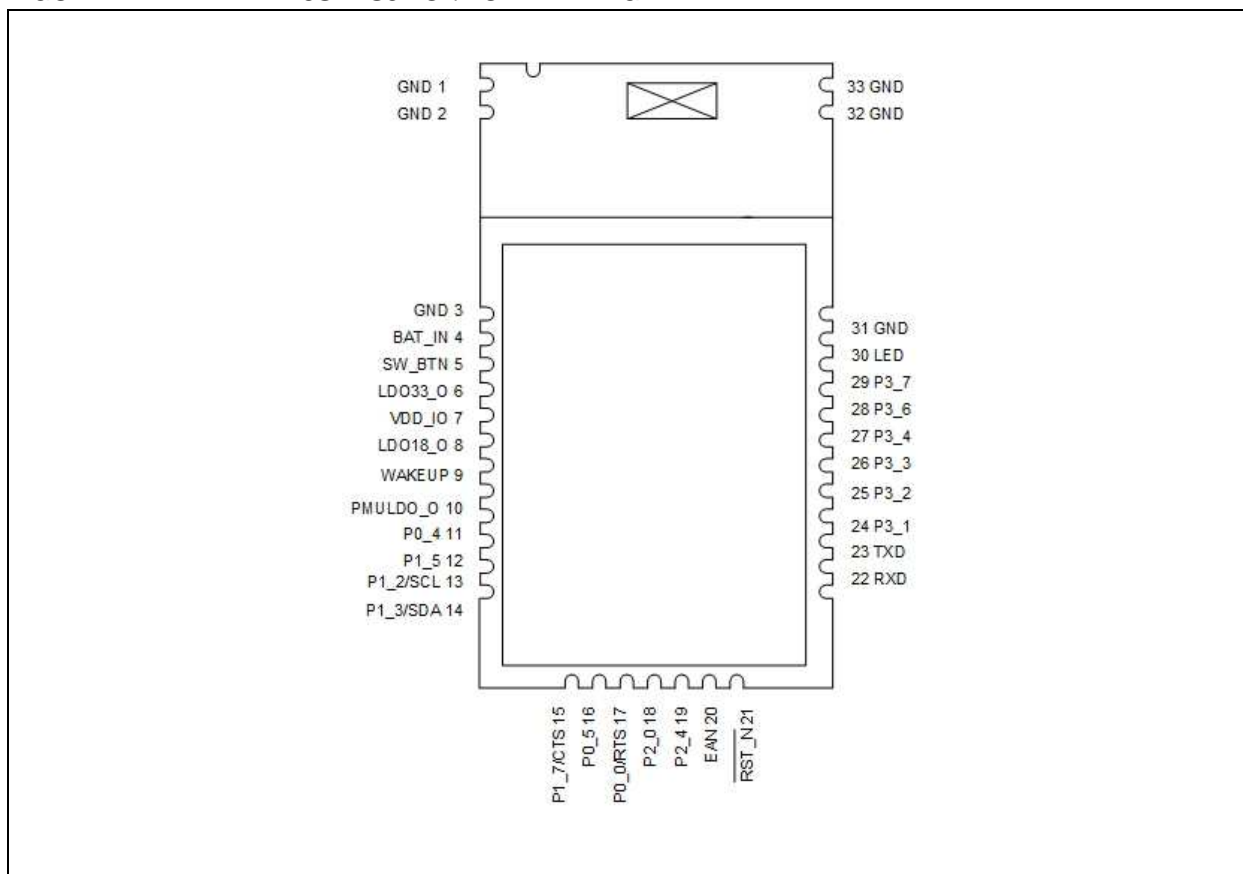



**FIGURE 1-3: BM78SPP05MC2/NC2 PIN DIAGRAM**

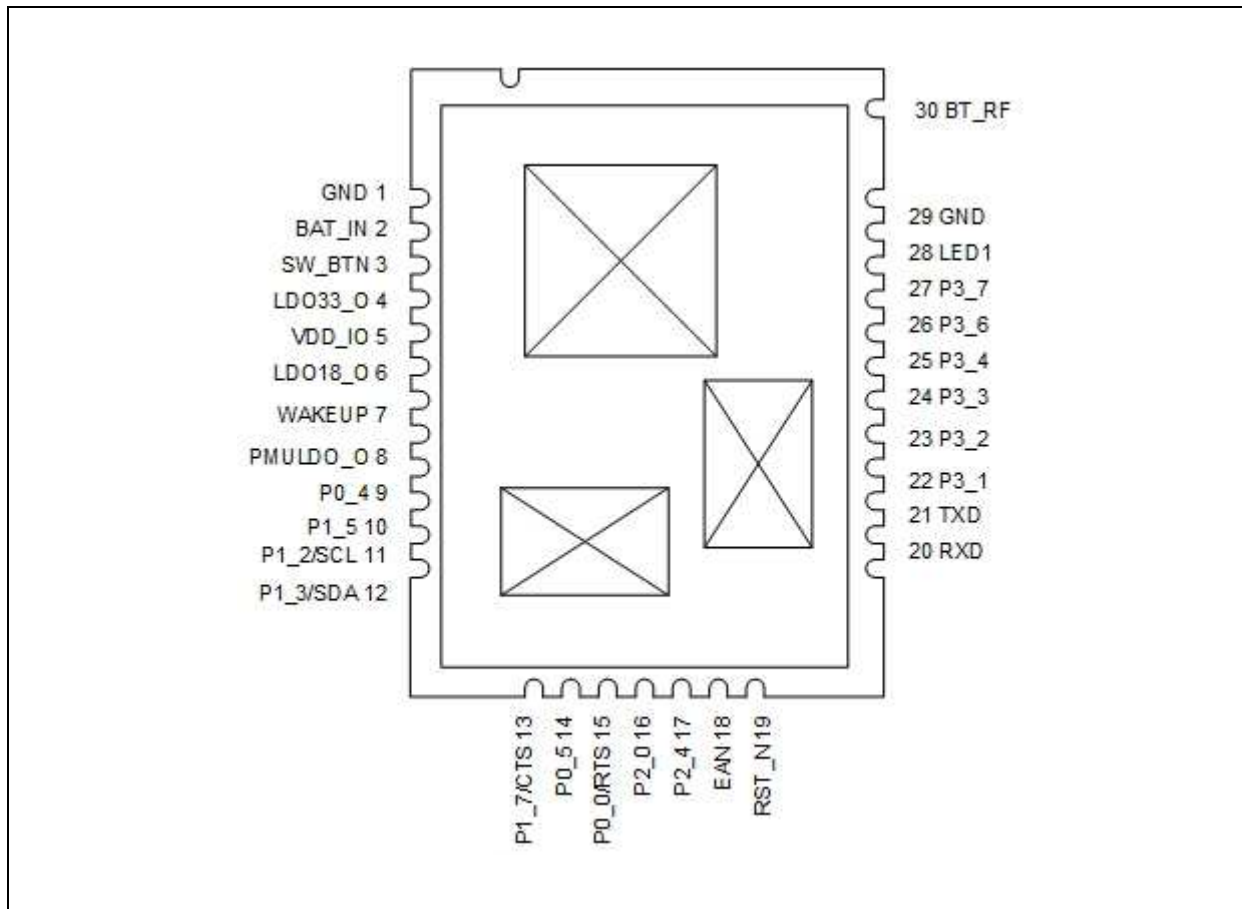

# BM78

---

NOTES:

## 2.0 APPLICATION INFORMATION

### 2.1 System Configuration

The I/O pins, P2\_0, P2\_4 and EAN, place the BM78 into operating mode and each of these pins have internal pull up and allow configuration settings and firmware to be updated from UART. [Table 2-1](#) provides system configuration details.

**TABLE 2-1: SYSTEM CONFIGURATION SETTINGS**

Module	P2_0	P2_4	EAN	Operational Mode
<b>BM78SPPx5NC2 (ROM Variant)</b>	Low	High	High	Write EEPROM and test mode
	High	High	High	Normal operation/application mode
<b>BM78SPPx5MC2 (Flash Variant)</b>	Low	Low	High	Write FLASH
	Low	High	Low	Write EEPROM and test mode
	High	High	Low	Normal operational/application mode

### 2.2 Control and Indication I/O Pins

The I/O pins, P0\_0, P0\_5, P1\_7, P3\_1, P3\_2, P3\_3, P3\_4, and P3\_7, are configurable control and indication pins. The control signals are inputs to the BM78 and the indication signals are outputs from the BM78. [Table 2-2](#) provides default I/O pin configuration details.

**TABLE 2-2: CONTROL AND INDICATION I/O PIN ASSIGNMENTS**

PINS	N/C	UART_RTS <sup>(1,2)</sup>	UART_CTS <sup>(1,2)</sup>	LOW_BATTERY_IND	RSSI_IND	GET_WIFI_INFO_KEY	LINK_DROP_CONTROL (DISCONNECT)	UART_RX_IND	PAIRING_KEY	INQUIRY CONTROL	PROFILE_IND
P0_0		■									
P0_5	■										
P1_7			■								
P3_1										■	
P3_2							■				
P3_3								■			
P3_4									■		
P3_7				■							

- Note 1:** The RTS pin can only be assigned to P0\_0 and the CTS pin can only be assigned to P1\_7.  
**2:** The RTS and CTS pins can be configured as GPIOs if flow control is disabled.

# BM78

## 2.3 Status Indication I/O Pins

The I/O pins, P1\_5 and P0\_4, are status indicator pins: Status\_IND\_1 and status\_IND\_2. Together these pins provide status indication to MCUs. [Table 2-3](#) provides status indication of the P1\_5 and P0\_4 pins.

**TABLE 2-3: STATUS INDICATION**

P1_5/STATUS_IND_1	P0_4/STATUS_IND_2	Indication
H	H	Power-on (default setting) and deep-sleep state. HH status should be stable for at least 500 ms.
H	L	Access state
L	H	Link state (UART data transmitting)
L	L	Link state (no UART data transmitted)

**Legend:** L = Low H = High

## 2.4 Power Tree

[Figure 2-1](#) illustrates the power tree diagram of the BM78.

**FIGURE 2-1: POWER TREE DIAGRAM**

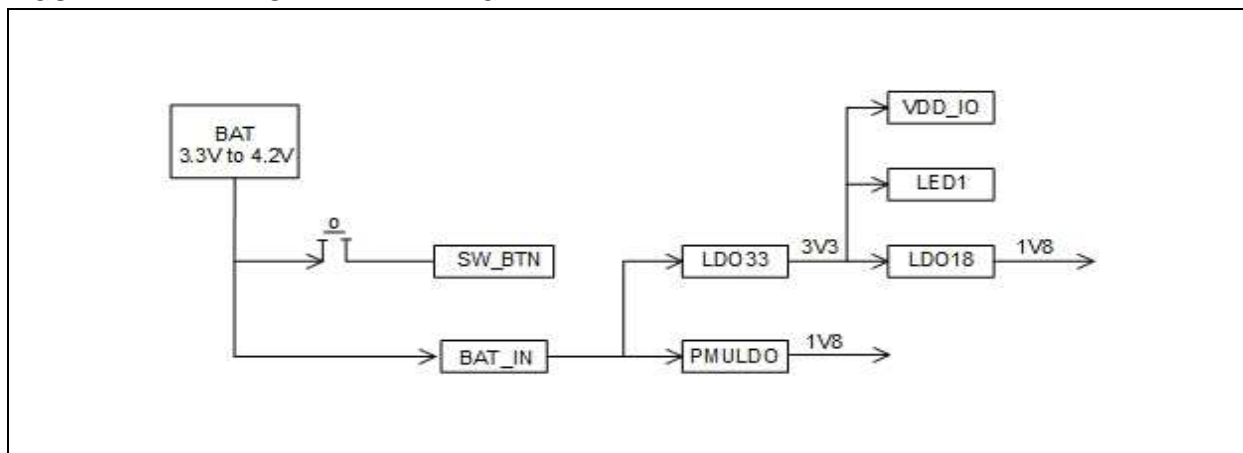

## 2.5 Software Button (SW\_BTN)

The Software Button (SW\_BTN) input pin powers the BM78 ON (high) or OFF (low) into the S4 mode. The S4 mode is the Deep-sleep mode and the S2 mode is the

Sleep mode. The S4 mode can only be triggered by the SW\_BTN pin, and the power consumption is lower in the S4 mode.

Figure 2-2 through Figure 2-4 display the waveforms for the BM78 in the high and low status, that is access and link status.

**FIGURE 2-2: SW\_BTN TIME (HIGH) AT APP MODE<sup>(1,2,3,4,5)</sup>**

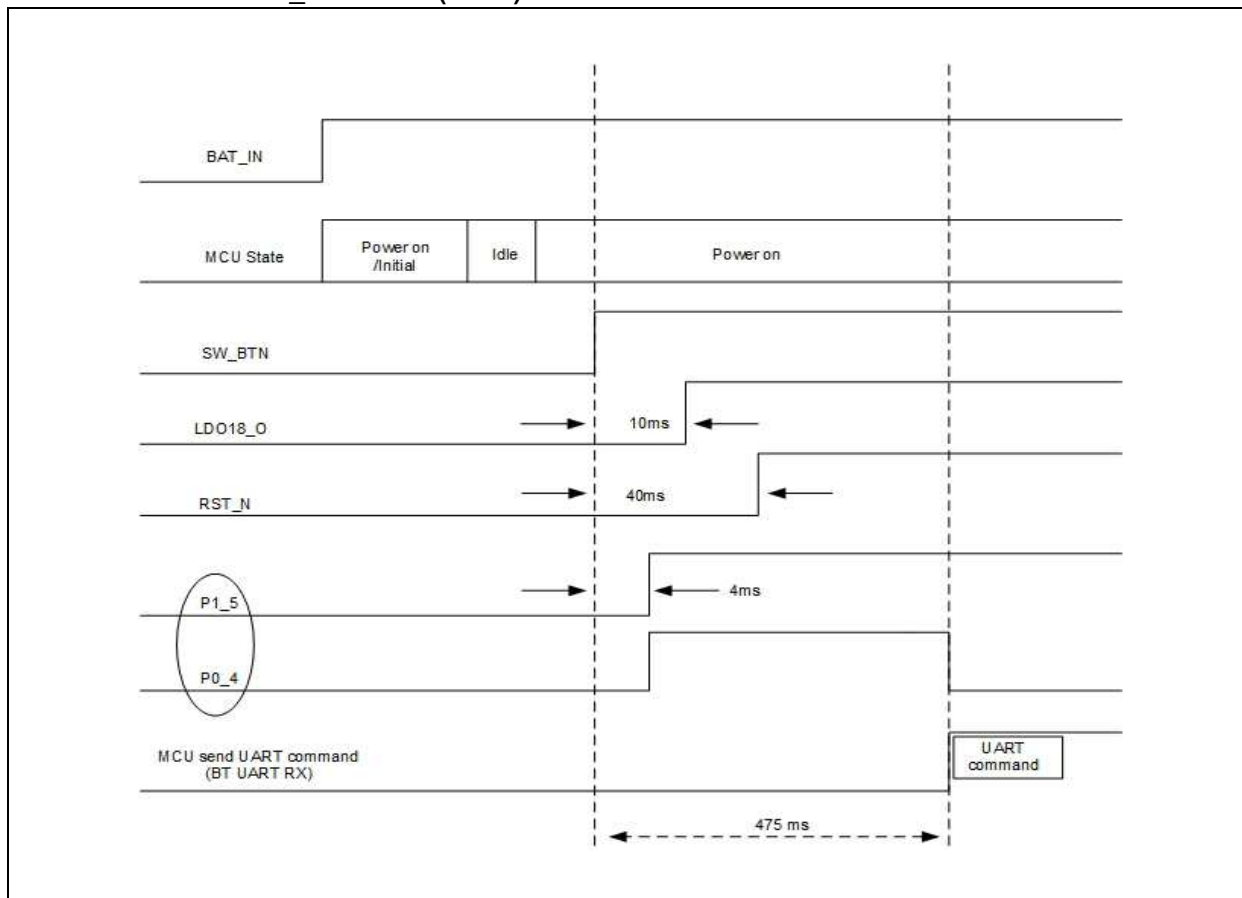

**Note 1:** MCU can send UART command, refer to [Table 2-3](#).

**2:** Time duration (475 ms) is for reference purpose only, check the status pin.

**3:** Reset is 'no connect'.

**4:** Time is configured as default setting.

**5:** Data corresponds to the BM78SPPx5NC2 (ROM variant) module.

**FIGURE 2-3: SW\_BTN TIME (LOW) AT ACCESS STATES<sup>(1,2,3)</sup>**

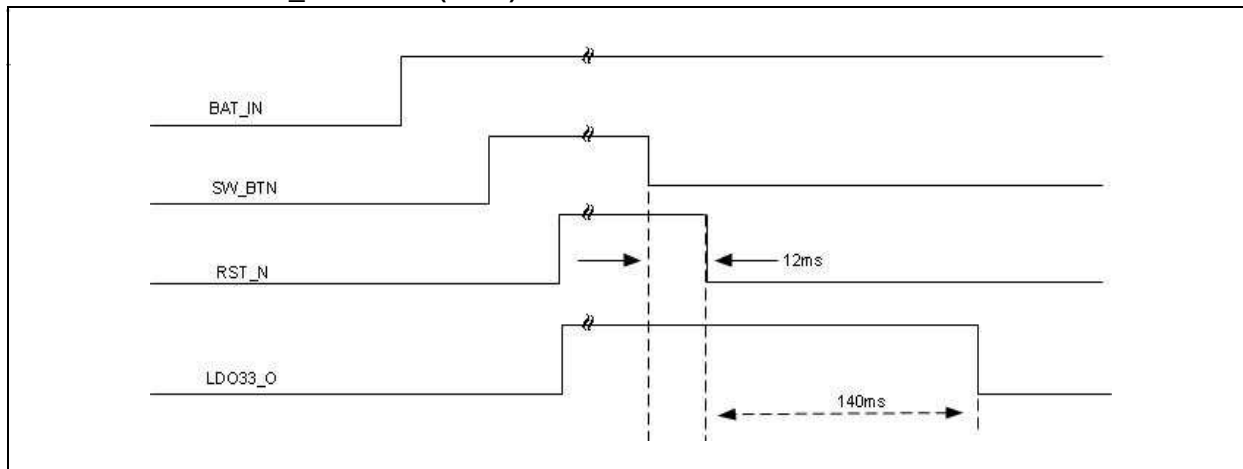

**Note 1:** Reset is 'no connect'.

**2:** Time is configured as default setting.

**3:** Data corresponds to the BM78SPPx5NC2 (ROM variant) module.

**FIGURE 2-4: SW\_BTN TIME (LOW) AT LINK STATES<sup>(1,2,3)</sup>**

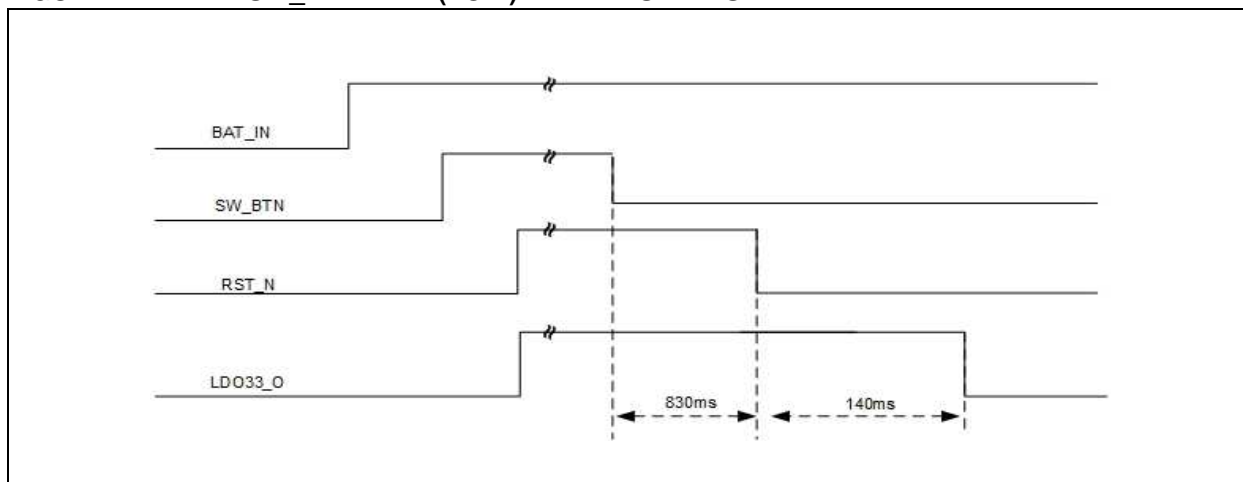

**Note 1:** 830 ms time duration is a typical value measured on iPhone 6 and this time duration can vary from one smart phone to another.

**2:** Reset is 'no connect'.

**3:** Time is configured as default setting.

## 2.6 WAKE UP

The WAKE UP input pin wakes the BM78 from Sleep mode (active-low) and wake up is always from Sleep mode (S2) to Standby mode. [Figure 2-5](#) illustrates the timing diagram of the BM78 in the Wake Up mode.

**FIGURE 2-5: WAKEUP TIME<sup>(1,2)</sup>**

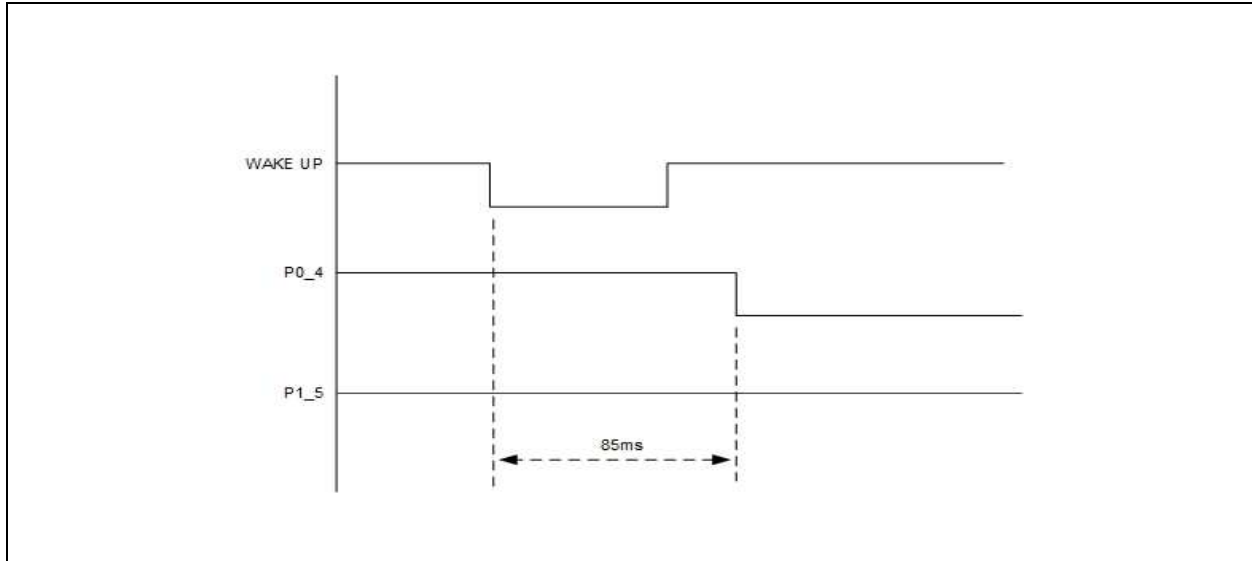

**Note 1:** 85 ms is for reference time and the user should check the status pin.

**2:** Refer to [Table 2-3](#) for the status of the P0\_4/P1\_5 pin.

# BM78

## 2.7 External Reset

The watchdog timer (WDT) can Reset the BM78 which has an integrated Power-on Reset (POR) circuit that reset all circuits to a known Power-on state. This action can also be driven by an external Reset signal that can be used to externally control the device, forcing it into a

Power-on Reset state. The Reset signal input is active-low and connection is not required in most of the applications.

Figure 2-6 illustrates the timing diagram of the BM78 when it is in the Reset (RST\_N is set to active low) state.

**FIGURE 2-6: TIMING WAVEFORMS ON RESET (WHEN RST\_N IS SET TO ACTIVE LOW)<sup>(1,2,3,4)</sup>**

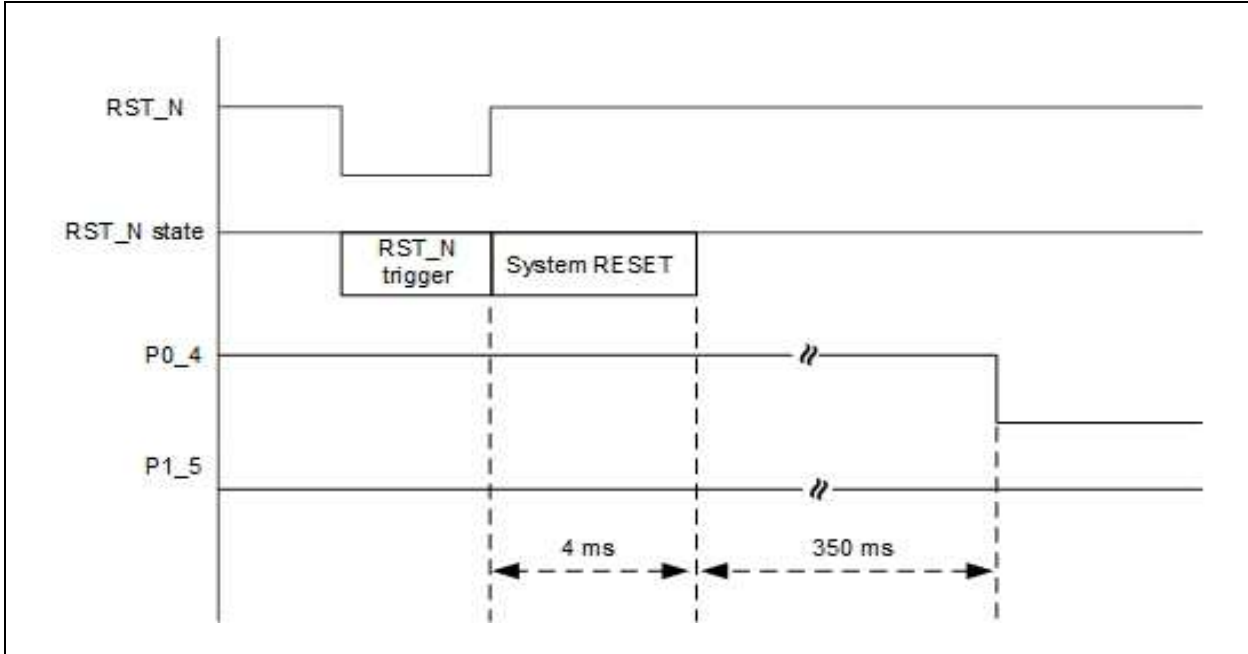

- Note 1:** Auto Pattern can use external Reset, refer to [Section 3.0 “Operating Pattern”](#).
- 2:** The RST\_N state trigger must be greater than 63 ns.
- 3:** Manual pattern can use external Reset and Reset command, refer to [Section 3.0 “Operating Pattern”](#).
- 4:** Time duration (350 ms) is for reference purpose only, check the status pin.



## 2.8 LED Driver

The BM78 has a dedicated LED driver and the LED (LED1) can be connected directly with the BM78 using this driver, see [Figure 2-7](#).

The maximum current sourcing for the LED is 5 mA and it provides 16 options (steps) to trim the brightness. The LED brightness can be configured using the User Interface (UI) tool, a Windows® configuration utility.

The following are status indication of the LED and each indication is a configurable flashing sequence:

- Standby
- Link Back
- Low Battery
- Inquiry
- Link

**FIGURE 2-7: LED DRIVER**

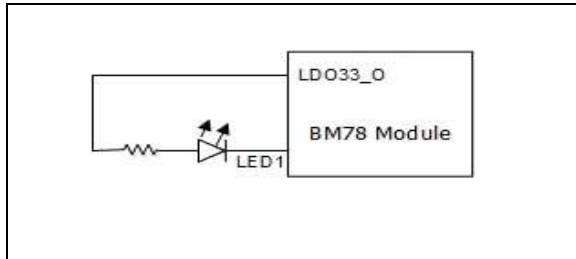

# BM78

## 2.9 Host MCU Interface over UART

Figure 2-8 illustrates an example of UART interface with host MCU and power scheme using 3.3V to the VDD. Battery power is applied to the BAT\_IN pin. From the LDO33\_O pin, voltage can be routed to the

VDD\_IO pin and external circuitry including the MCU. This power scheme ensures that the BM78 and MCU I/O voltages are compatible.

**Note:** The internal 3.3V LDO current source should not exceed 50 mA (i.e maximum).

**FIGURE 2-8: POWER AND MCU INTERFACE EXAMPLE FOR BM78**

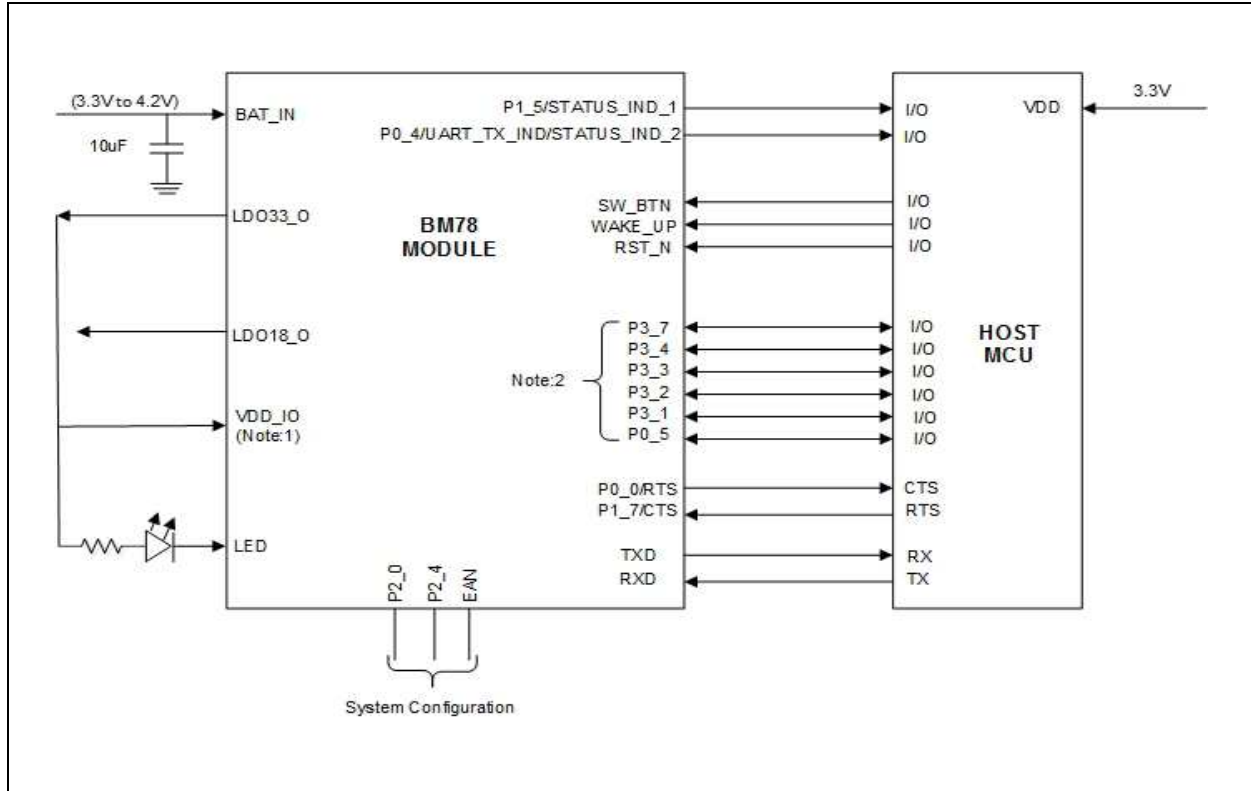

**Note 1:** Ensure that VDD\_IO and MCU VDD voltages are compatible.

**2:** The control and indication ports are configurable

### 2.10 Reference Circuit

Figure 2-9 through Figure 2-12 illustrate the reference schematic of the power supply design implemented for the BM78.

**FIGURE 2-9: BM78SPP05MC2/NC2 REFERENCE CIRCUIT**

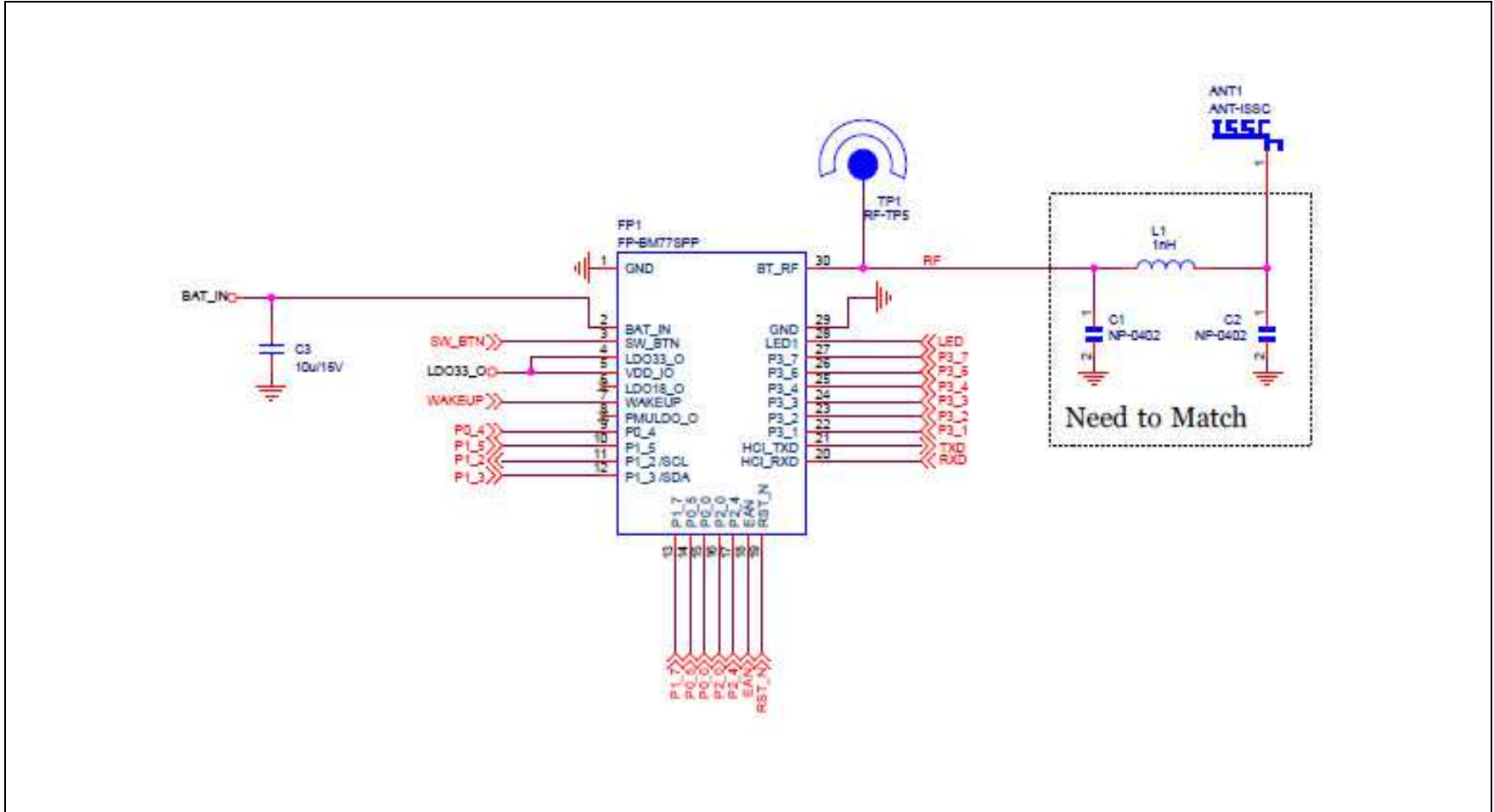

FIGURE 2-10: BM78SPP05MC2/NC2 REFERENCE CIRCUIT

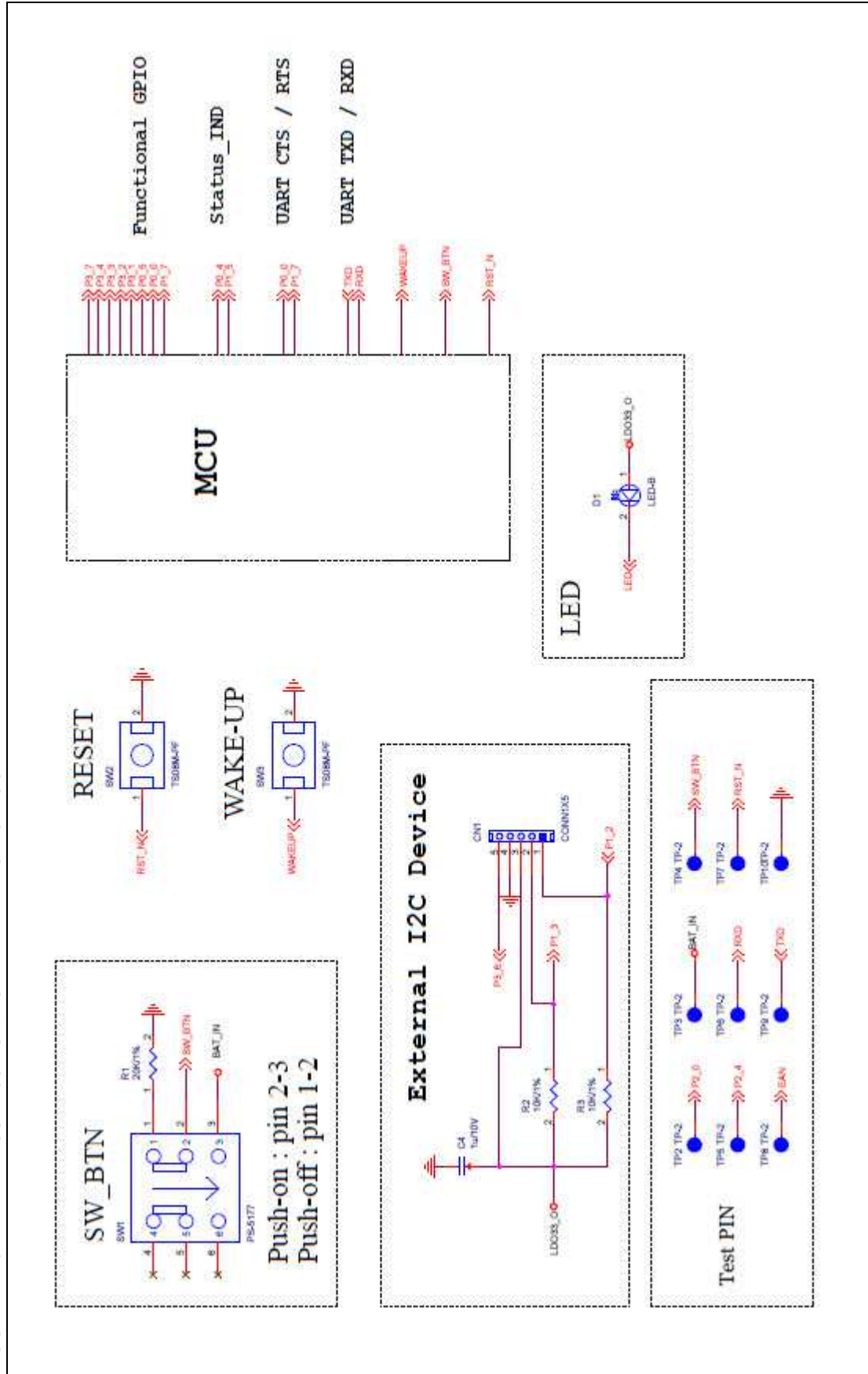

FIGURE 2-11: BM78SPPS5MC2/NC2 REFERENCE CIRCUIT

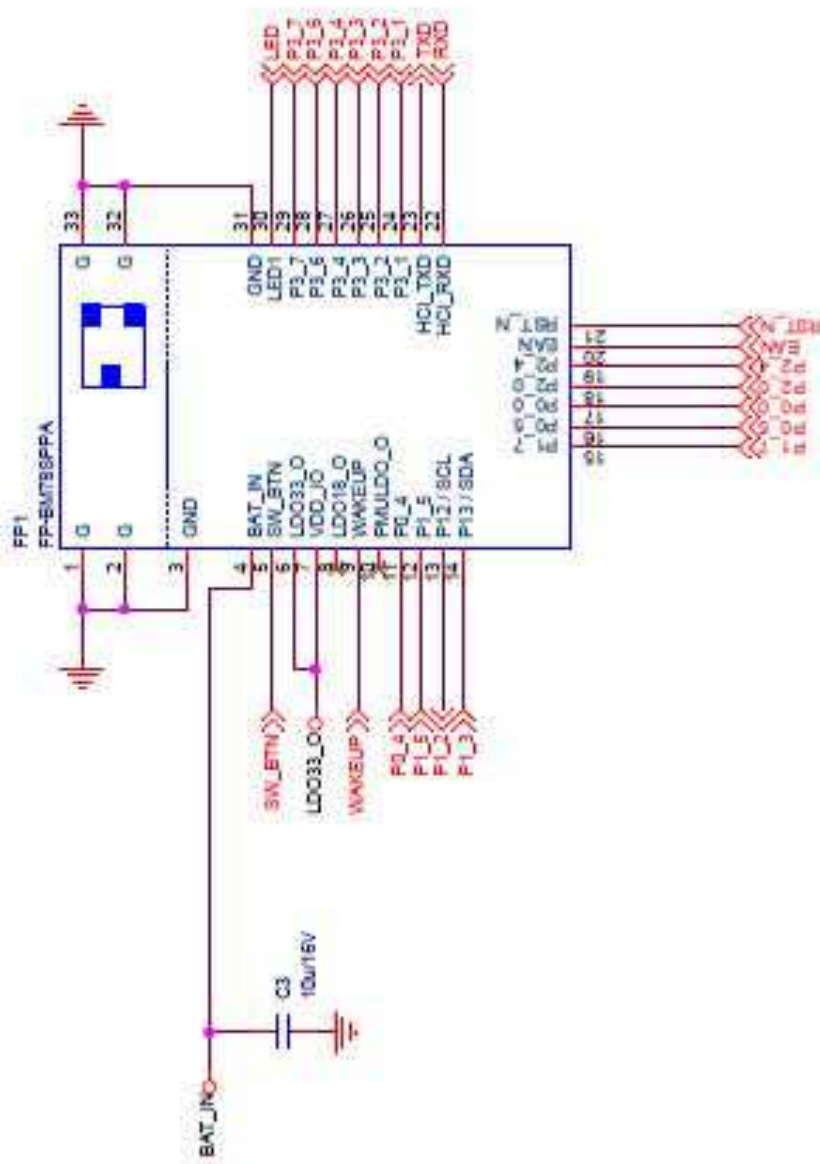
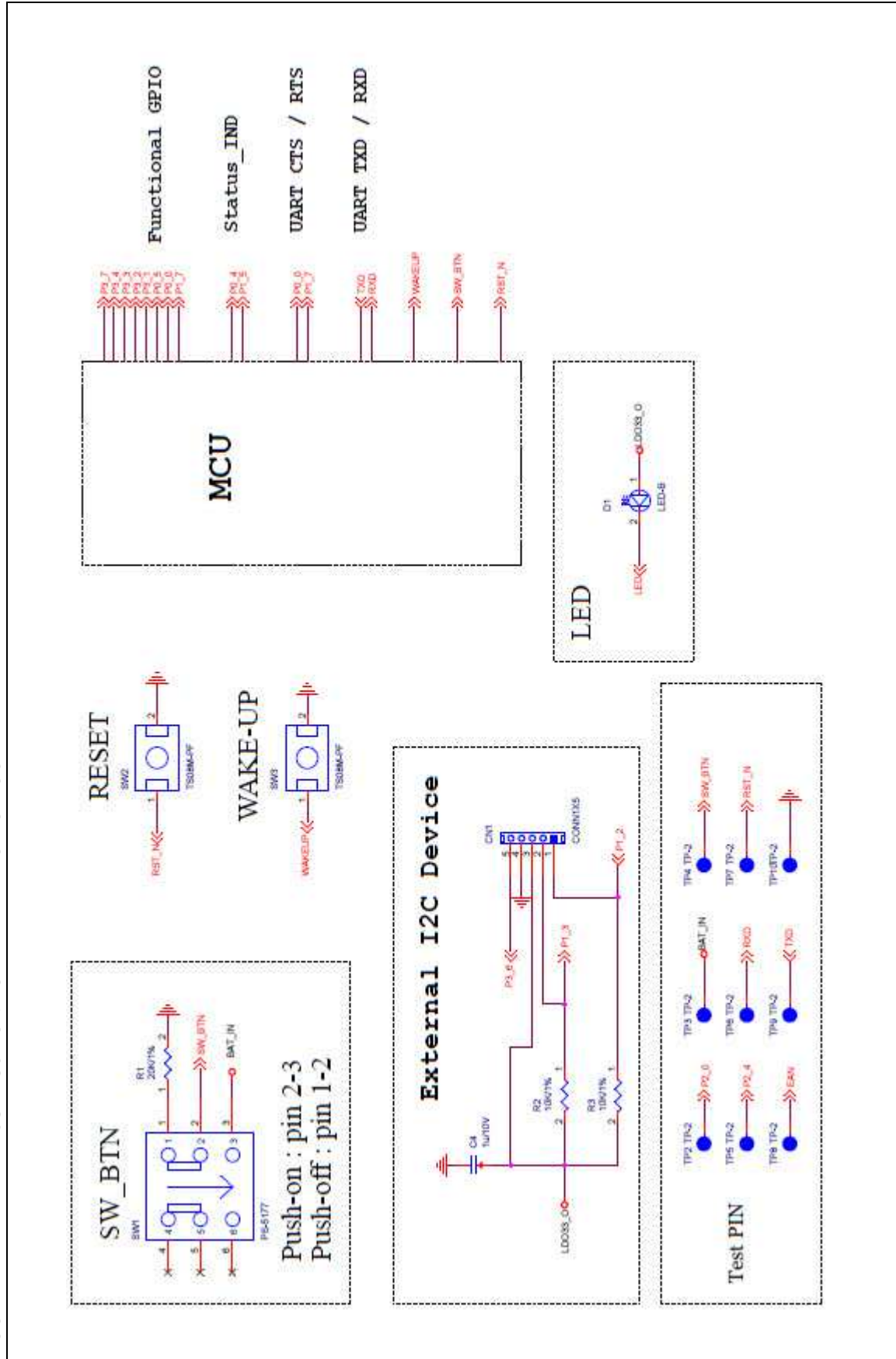

FIGURE 2-12: BM78SPPS5MC2/NC2 REFERENCE CIRCUIT



## 3.0 OPERATING PATTERN

The BM78 provides two operating patterns, Auto Pattern and Manual Pattern, and the operating modes can be configured through the UI tool or the host MCU. See [Figure 3-1](#).

If the `Auto_Pattern_Setting` parameter is enabled, the BM78 triggers the Auto Pattern state machine otherwise Manual Pattern is used. Configure mode is available only in Auto Pattern and it can be enabled or disabled by the UI settings or host MCU.

**FIGURE 3-1: OPERATING PATTERN CONFIGURATION**

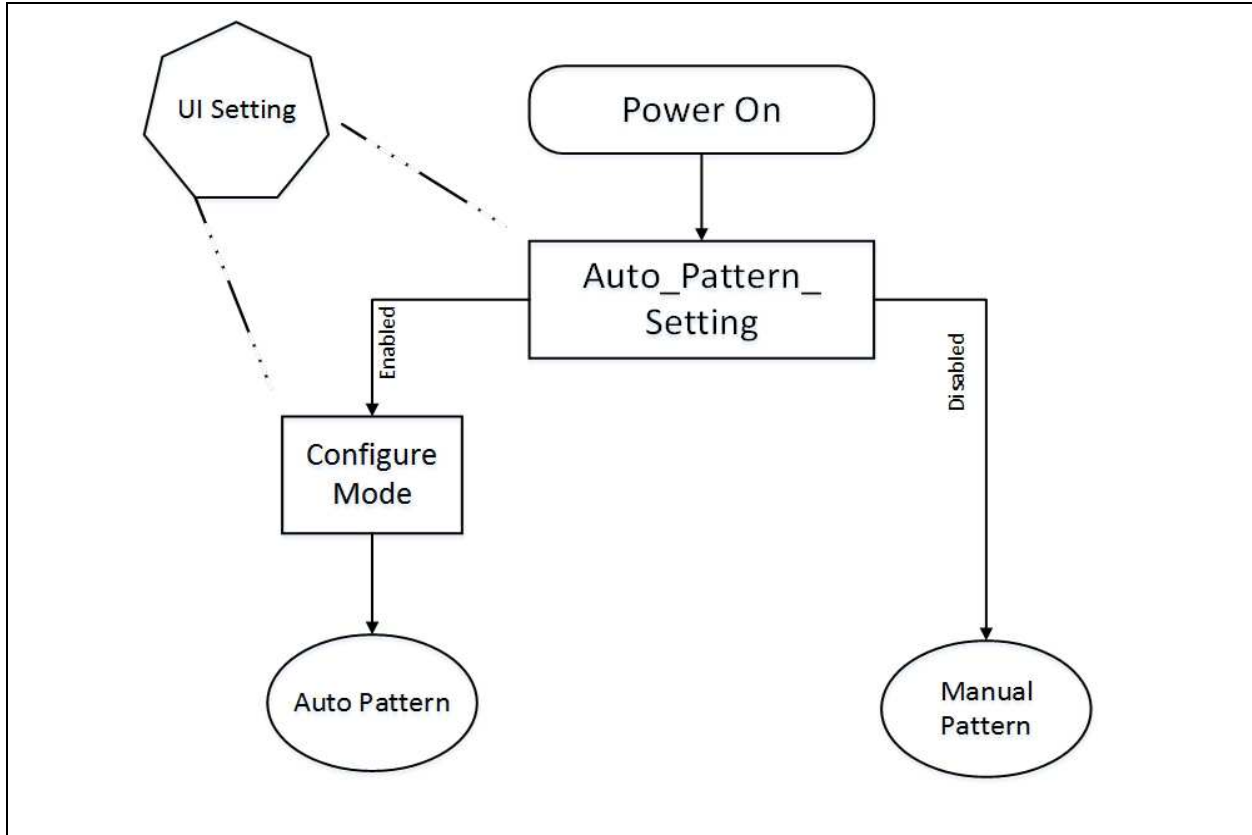

# BM78

## 3.1 Auto Pattern

In Auto Pattern, the BM78 automatically operates after power on without any interference from the MCU. Auto Pattern is the basic application of the BM78. [Figure 3-2](#) illustrates the characteristics of Auto Pattern.

**FIGURE 3-2: AUTO PATTERN CHARACTERISTIC**

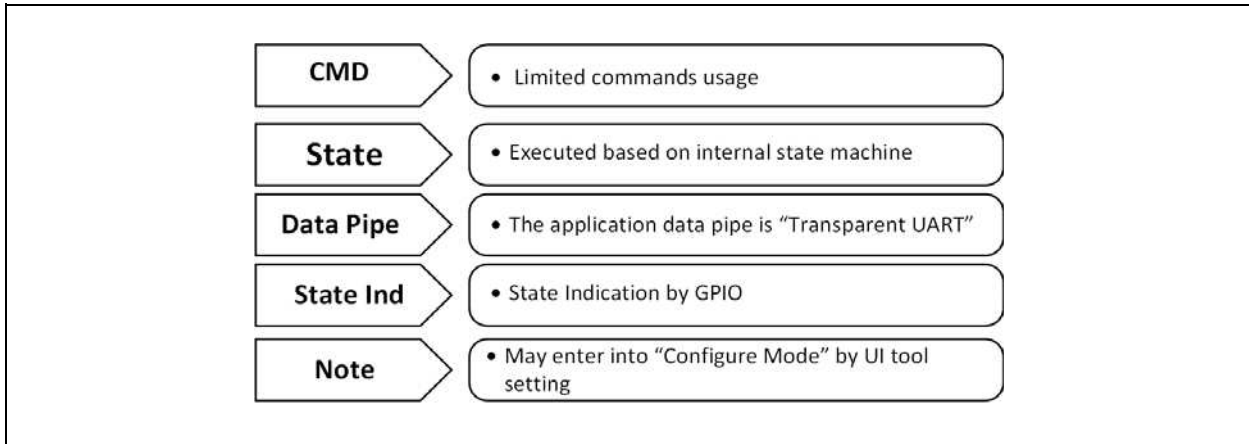

Although the BM78 is set to operate in Auto Pattern mode, it provides the flexibility for the MCU to perform some specific settings in Configure mode by command set. If the BM78 has enabled authenticated pairing, the command set is required to accomplish the Bluetooth link. The MCU doesn't have to deal with the BM78 state, and the BM78 changes its state after power on. However, the MCU can terminate the connection by using GPIOs. The transparent pipe is used for application data transmission and data is transmitted between the remote host and MCU.

The MCU knows the state of the BM78 by GPIOs. The configure mode is available only in Auto Pattern and it can be enabled or disabled by UI tool settings. Basically, the MCU is communicating with the BM78 by GPIOs, except for data transmission.

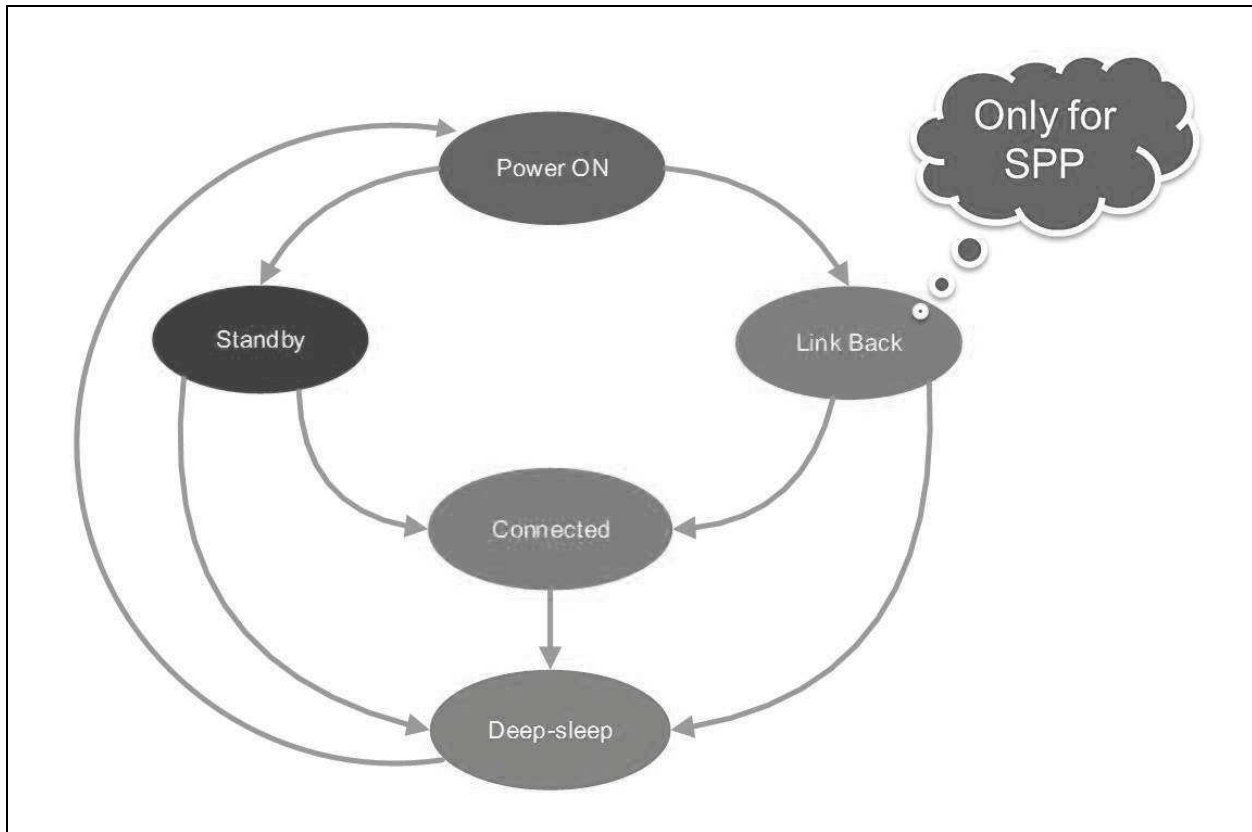

Figure 3-3 illustrates how the BM78 changes its own state. After power on, there are two options, one is to enter Stand-by mode and the other is to enter Link-Back mode, and it depends on if any device is recorded in the BM78. Irrespective of the mode, the BM78 waits for the remote side to establish a connection or tries to establish a connection with the remote side. Once the connection is established, the state of

the BM78 changes to connected mode. If the connection is terminated, the BM78 goes into Deep-Sleep mode.

**Note:** Link-Back mode is available only for SPP profile or mode.

**FIGURE 3-3: BM78 INTERNAL STATE MACHINE**



The BM78 stays in Access state and it is ready for a remote host to access. It either waits for the remote side to create a connection or tries to create a connection on its own.

**TABLE 3-1: STATE INDICATION**

State	Mode
Access State	Configure Mode
	Stand-by Mode
	Link-Back mode
	Pairing Procedure
Link State	Connected Mode
Deep-sleep State	Deep-Sleep Mode

Configure mode and pairing procedure are also defined as Access state. If the BM78 enters link state, it means not only the Bluetooth link has been established successfully, but also the data session is triggered. MCUs can transmit data to a remote host or receive data from a remote host in this state.

# BM78

Figure 3-4 illustrates Auto Pattern transparent pipe. If MCU wants to send data (12345) to the remote side, the data should be in the `.hex` format to the BM78 and the BM78 transmits the received data to the remote side. Similarly, if the BM78 receives data from the remote host, it sends the data in the `.hex` format to the MCU.

**FIGURE 3-4: AUTO PATTERN TRANSPARENT PIPE**



## 3.2 Manual Pattern

In Manual Pattern, the MCU communicates with the BM78 using command sets. The MCU must send correct commands to handle the state of the BM78. The change in the BM78 state is based on the MCU commands.

The data pipe for Manual Pattern is different from Auto Pattern. Since the MCU is communicating with the BM78 by command sets, the data transmission will follow the command set rule. This is defined as protocol pipe. In Manual Pattern, the MCU can get the detail status by the `BM78_Status_Report` event.

Figure 3-5 illustrates the characteristics of Manual Pattern.

**FIGURE 3-5: MANUAL PATTERN CHARACTERISTICS**

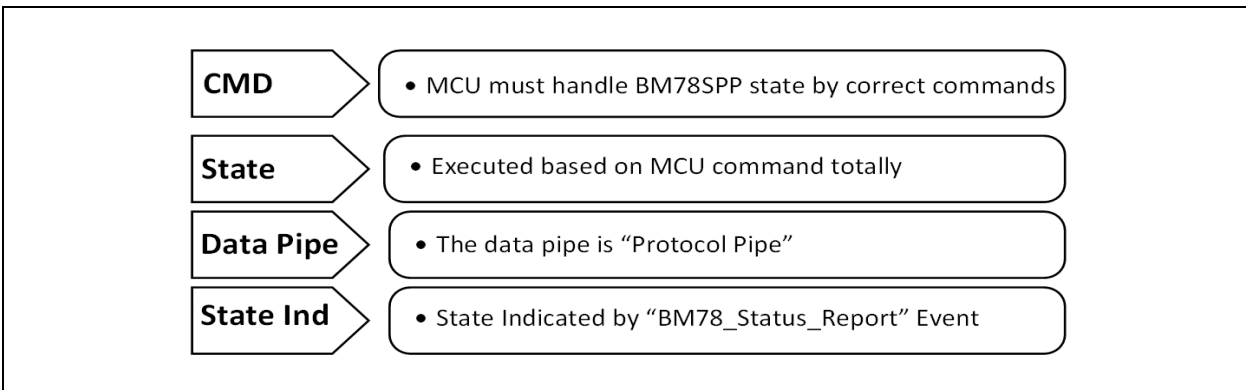
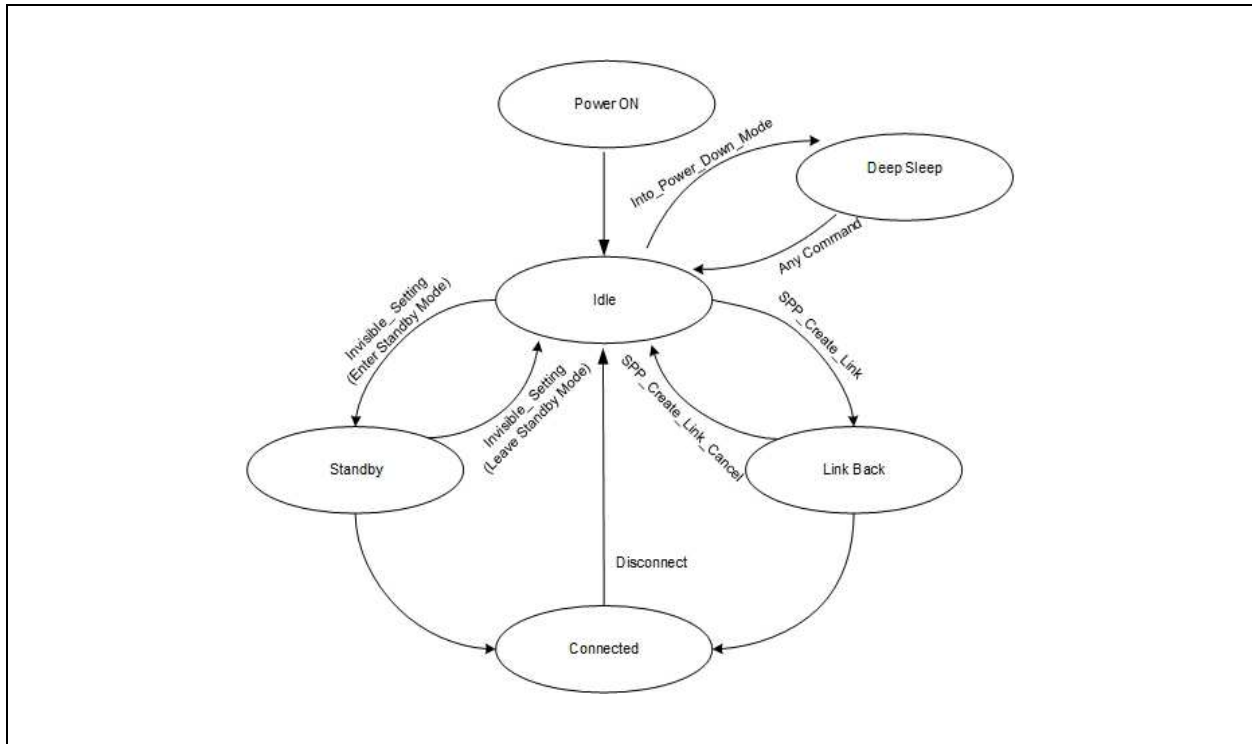

Figure 3-6 illustrates the MCU state change in Manual Pattern. For Manual Pattern, all MCU state change requires a corresponding command. For example, the MCU sends the `Invisible_Setting` command with the parameter `Enter_Standby_Mode`, then the BM78 goes into stand-by mode. The MCU sends the `SPP_Create_Link` command, then BM78 goes into Link-Back mode.

In Auto Pattern, the BM78 goes into Deep-Sleep mode once the connection is terminated, and in Manual Pattern the BM78 stays in Idle mode even after the con-

nection is terminated. The MCU should decide on the mode of the BM78 once the connection is terminated, that is based on the overall system behavior.

**FIGURE 3-6: STATE CHANGES BY MCU IN MANUAL PATTERN**



# BM78

Figure 3-7 illustrates the Manual Pattern protocol pipe. If the MCU wants to send data (12345) to remote side, the data format should follow the UART command protocol.

**FIGURE 3-7: MANUAL PATTERN PROTOCOL PIPE**



## 3.3 Mode Definition

### 3.3.1 CONFIGURE MODE

The Configure mode configures the relative settings before the BM78 enters into Auto Pattern state. If Configure mode is enabled, the BM78 will send Configure mode status event to notify the MCU that the BM78 is ready to receive commands. If the BM78 doesn't

receive any valid command within the specified Configure mode time, it will exit from Configure mode automatically. Once the MCU sends any valid command within the Configure mode time, the BM78 will not exit Configure mode until the MCU gives the leave Configure mode command. Once the BM78 exits from Configure mode, it goes to process Auto Pattern state machine.

**FIGURE 3-8: CONFIGURE MODE**

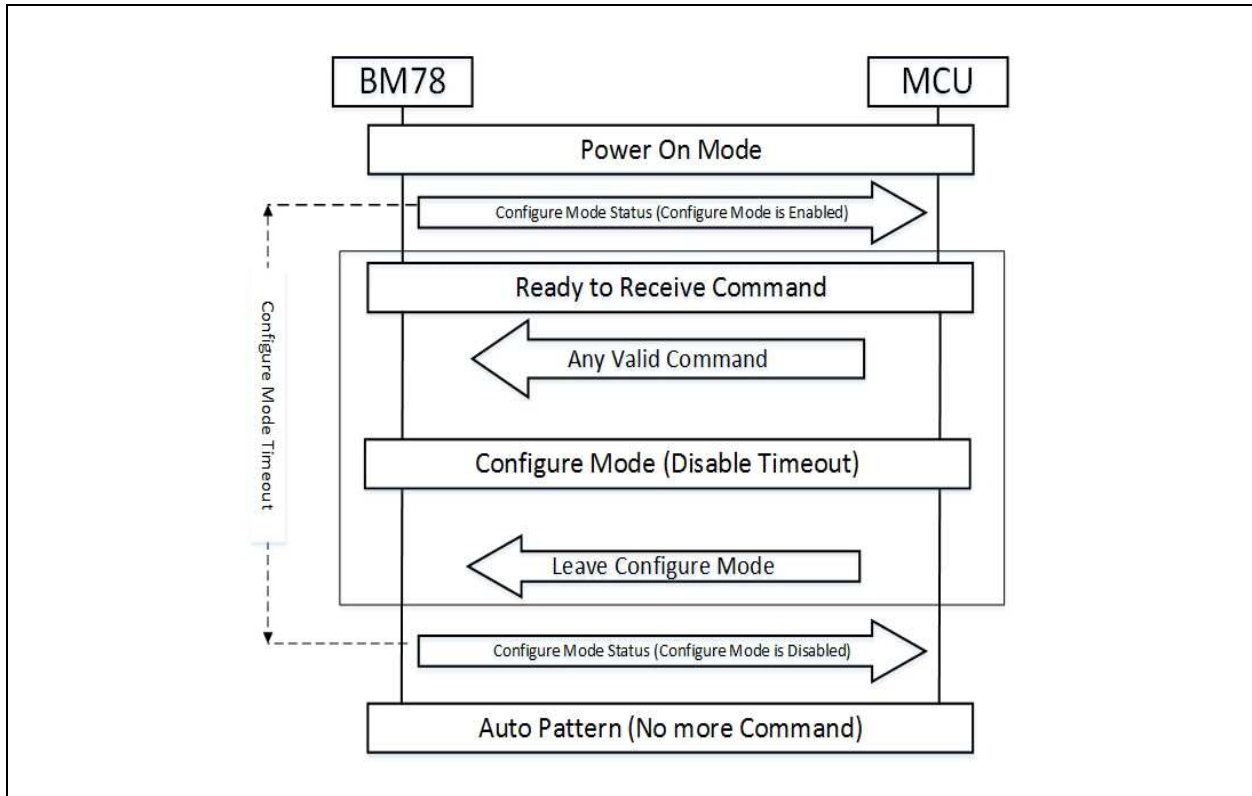

## 3.3.2 STANDBY MODE

- SPP (BR/EDR)
  - Enable the inquiry scan and page scan in this mode
  - Configurable to be discoverable
  - Ready to be paired
- Bluetooth Low Energy (BLE)
  - Enable the undirected advertising in this mode
  - Ready to be paired

## 3.3.3 LINK-BACK MODE

- SPP (BR/EDR)
  - Enable page procedure to establish dedicated or last connected Bluetooth SPP link
  - Configurable to be invisible situation
- BLE
  - No BLE link-back behavior because of iOS limitation
  - Configurable to be invisible situation
  - Ready to be paired

## 3.3.4 CONNECTED MODE

- SPP (BR/EDR)
  - Use SPP or iAP protocol to exchange the application data
  - Connection Establish status: SPP Connected mode
- BLE
  - Use GATT protocol to exchange the application data
  - Connection establish status: BLE Connected mode

## 3.3.5 DEEP-SLEEP MODE

- Auto Pattern
  - Enter into Deep-Sleep mode automatically
  - Wake-up trigger: Wakeup pin
- Manual Pattern
  - Enter into Deep-Sleep mode by MCU command assign
  - Wake-up trigger: Wakeup pin or UART\_RX\_Ind pin

## 4.0 ELECTRICAL CHARACTERISTICS

This section provides an overview of the electrical characteristics of the BM78 module. Additional information will be provided in future revisions of this document as it becomes available.

Absolute maximum ratings for the BM78 devices are listed below. Exposure to these maximum rating conditions for extended periods may affect device reliability. Functional operation of the device at these or any other conditions, above the parameters indicated in the operation listings of this specification, is not implied.

### Absolute Maximum Ratings

Ambient temperature under bias.....	-20°C to +70°C
Storage temperature .....	-65°C to +150°C
Voltage on VDD with respect to VSS .....	-0.3V to +3.6V
Maximum output current sunk by any I/O pin.....	12 mA
Maximum output current sourced by any I/O pin.....	12 mA

**Note:** Stresses above those listed under “**Absolute Maximum Ratings**” may cause permanent damage to the device. This is a stress rating only and functional operation of the device at those or any other conditions, above those indicated in the operation listings of this specification, is not implied. Exposure to maximum rating conditions for extended periods may affect device reliability.

# BM78

Table 4-1 through Table 4-7 provide the recommended operating conditions and the electrical specifications of the BM78.

**TABLE 4-1: RECOMMENDED OPERATING CONDITIONS**

Rating		Min.	Typical	Max.
Ambient Operating temperature range		-20°C	+25°C	+70°C
Relative Humidity (Operating)		10%	—	90%
Relative Humidity (Storage)		10%	—	90%
ESD	HBM	—	±2KV	—
	MM	—	±200V	—
HTOL (Note 1)		—	1000 hrs	—
Supply voltage: BAT_IN		3.3V	—	4.2V
Supply voltage: 1V8, VCC_RF, VDD_XO, AVDD_SAR		1.8V	1.9V	2.1V
SW_BTN		3.3V	—	4.2V
LED1		—	—	3.6V
Reset $V_{TH,res}$ threshold voltage		—	1.6V	—
$V_{IL}$ input logic levels low		-0.3V	—	0.8V
$V_{IH}$ input logic levels high		2.0V	—	3.6V
$V_{OL}$ output logic levels low ( $I_{OI} = 12mA$ )		—	—	0.4V
$V_{OH}$ output logic levels high ( $I_{Oh} = 12mA$ )		2.4V	—	—
RF continuous Tx mode		—	—	43 mA
RF continuous Rx mode		—	—	37 mA

**Note 1:** HTOL life test condition: +125°C, BAT\_IN = 4.2V, LDO33\_O = 3.3V, LDO18\_O = 1.9V.

**TABLE 4-2: 3.3V LDO ELECTRICAL PARAMETERS<sup>(1,2)</sup>**

Parameter	Min.	Typical	Max.	Unit
Operating Temperature	-20	—	+70	°C
Output Current ( $V_{IN} = 3.6V$ /load regulation with 100mV drop)	—	100	—	mA
Quiescent Current ( $V_{IN} = 3.6V$ )	—	150	—	uA

**Note 1:** With 10 uF capacitor at LDO33\_O as the condition for IP verification.

**2:** Output voltage can be calibrated using the MP tool

**TABLE 4-3: PMU LDO<sup>(1,2)</sup>**

Parameter	Min.	Typical	Max.	Unit
Operating Temperature	-20	—	+70	°C
Output Current ( $V_{IN} = 3.6V$ /load regulation with 0.3mV drop)	—	100	—	uA
Quiescent Current ( $V_{IN} = 3.6V$ )	—	120	—	uA

**Note 1:** With 1uF capacitor at PMULDO\_O as the condition for IP verification.

**2:** Output voltage can be calibrated by using the MP tool.

**TABLE 4-4: SAR-ADC AND BATTERY VOLTAGE DETECTOR**

Parameter	Min.	Typical	Max.	Unit
Operating Temperature	-20	—	+70	°C



**TABLE 4-4: SAR-ADC AND BATTERY VOLTAGE DETECTOR**

Parameter	Min.	Typical	Max.	Unit
AVDD_SAR power supply	—	1.8	—	V
SAR_BAT detection ( <b>Note 1</b> )	3.3	—	4.2	V
Resolution	—	10	—	bit
Operating Current (including bandgap)	—	—	1	mA
Deep-sleep Current	—	—	1	uA

**Note 1:** SAR\_BAT is connected with BAT\_IN internally for battery voltage detection.

**TABLE 4-5: INTENSITY CONTROLLABLE LED DRIVER**

Parameter	Min.	Typical	Max.	Unit
Operating Temperature	-20	—	+70	°C
Open-drain Voltage	—	—	3.6	V
Current Step	—	0.3	—	mA
Programmable Current Range	0	—	5	mA
Intensity control	—	16	—	step
Power down open-drain current	—	—	1	uA
Deep-sleep Current	—	—	1	uA

**TABLE 4-6: POWER CONSUMPTION-CLASSIC<sup>(1,2)</sup>**

Test Condition	Current Consumption (avg.) (mA)	Remarks
Standby mode	2.543	—
Deep-sleep mode	0.187	—
Connected+Sniff, Master (no data)	0.541	No data was transmitted Sniff interval = 500 ms
Connected+Sniff, Slave (no data)	0.551	No data was transmitted Sniff interval = 500 ms
Data, Master	10.67	Data transmitted at 115200 bps; block size = 500
Data, Slave	14.87	Data transmitted at 115200 bps; block size = 500

**Note 1:** Classic BR/EDR and RX\_IND functions are enabled.

**2:** The data corresponds to BM78SPPx5NC2 (ROM variant).

**TABLE 4-7: POWER CONSUMPTION-LOW ENERGY<sup>(1,2,3)</sup>**

Test Condition	Current Consumption (avg.) (mA)	Remarks
Deep-sleep mode	0.13	—
LE fast advertising	1.21	LE fast advertising interval = 100 ms
	0.88	LE fast advertising interval = 160 ms
	0.48	LE fast advertising interval = 500 ms
	1.72	LE fast advertising interval = 100 ms+ Beacon 100 ms
	0.62	LE fast advertising interval = 500 ms+ Beacon 500 ms

# BM78

**TABLE 4-7: POWER CONSUMPTION-LOW ENERGY<sup>(1,2,3)</sup> (CONTINUED)**

Test Condition	Current Consumption (avg.) (mA)	Remarks
Reduced power advertising	0.39	LE Reduced Power advertising interval = 961 ms
	1.00	LE Reduced Power advertising interval = 961 ms+Beacon 100 ms
	0.51	LE Reduced Power advertising interval = 961 ms+Beacon 500 ms
Connected (No data)	0.39	Connection interval = 1500 ms
	0.43	Connection interval = 600 ms
Connected (iPhone <sup>®</sup> 6 to module)	0.45	Connection interval = 500 ms
	0.60	Connection interval = 200 ms
Connected (module to iPhone 6)	6.6	Connection interval = 500 ms
	7.0	Connection interval = 200 ms

**Note 1:** Low energy, RX\_IND function is enabled.

**2:** Data corresponds to the BM78SPPx5NC2 (ROM variant).

**3:** Only low energy

## 5.0 RADIO CHARACTERISTICS

Table 5-1 provides the transmitter performance characteristics of the BM78 module.

**TABLE 5-1: TRANSMITTER PERFORMANCE<sup>(1,2)</sup>**

	Min.	Typical	Max.	Bluetooth Specification	Unit
BDR power	—	1.5	—	-6 ~ +4	dBm
EDR (2M/3M) power	—	-1	—	-6 ~ +4	
LE power	—	0.5	—	-20 ~ +10	

**Note 1:** The RF Transmit power can be calibrated during production by using the MP Tool software and the MT8852 Bluetooth Test equipment.

**2:** Test condition: VCC RF = 1.80V, temperature = 25°C.

Table 5-2 provides the receiver performance characteristics of the BM78 module.

**TABLE 5-2: RECEIVER PERFORMANCE<sup>(1)</sup>**

	Min.	Typical	Max.	Bluetooth Specification	Unit
BDR Sensitivity	—	-90	—	≤-70	dBm
EDR 2M Sensitivity	—	-90	—		
EDR 3M Sensitivity	—	-82	—		
LE Sensitivity	—	-92	—		

**Note 1:** Test condition: VCC RF = 1.80V, temperature = 25°C.

# BM78

---

NOTES:

## 6.0 PHYSICAL DIMENSIONS

Figure 6-1 illustrates the physical dimensions of the BM78SPPS5MC2/NC2 module.

**FIGURE 6-1: BM78SPPS5MC2/NC2 MODULE DIMENSIONS**

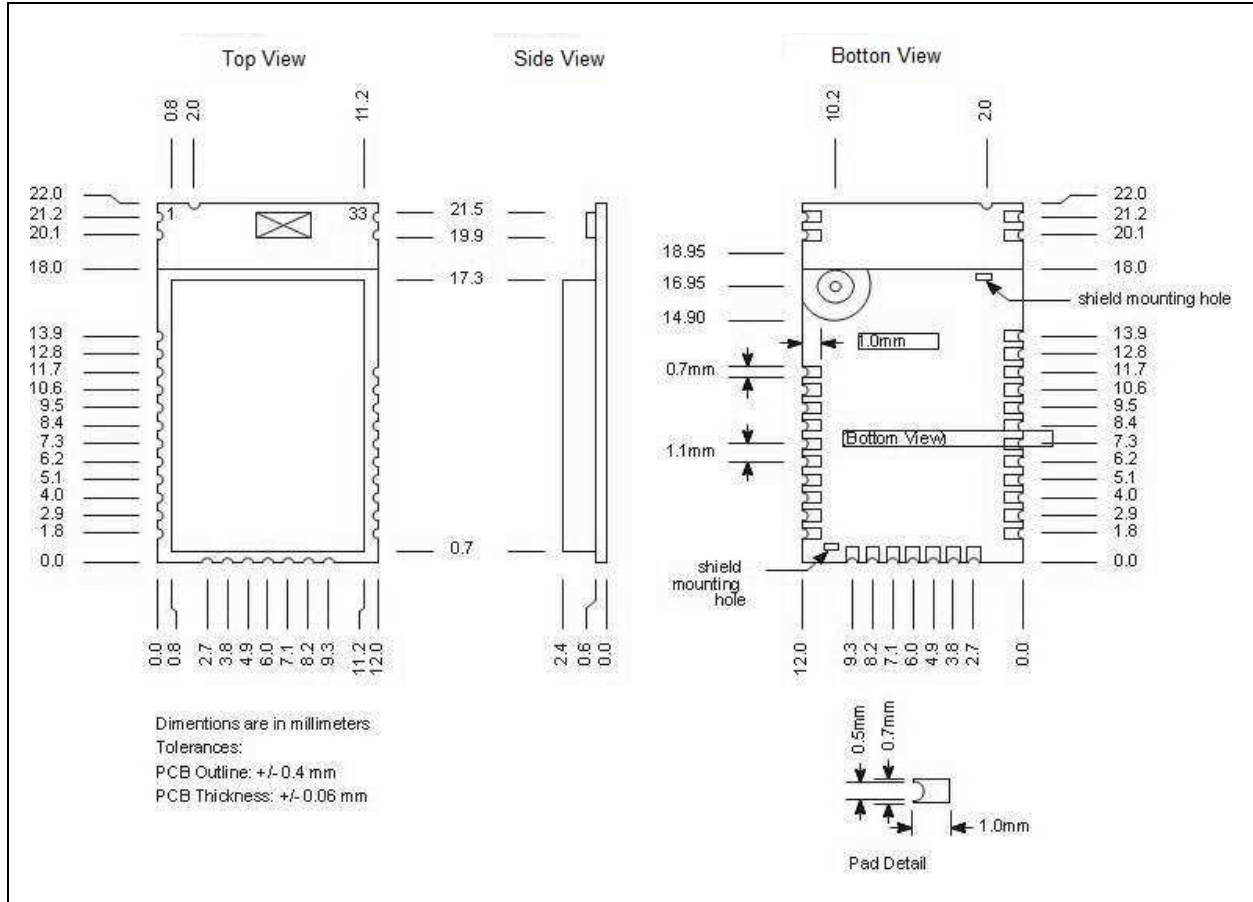

# BM78

Figure 6-2 illustrates the recommended host PCB foot print.

**FIGURE 6-2: BM78SPPS5MC2/NC2 RECOMMENDED PCB FOOTPRINT**

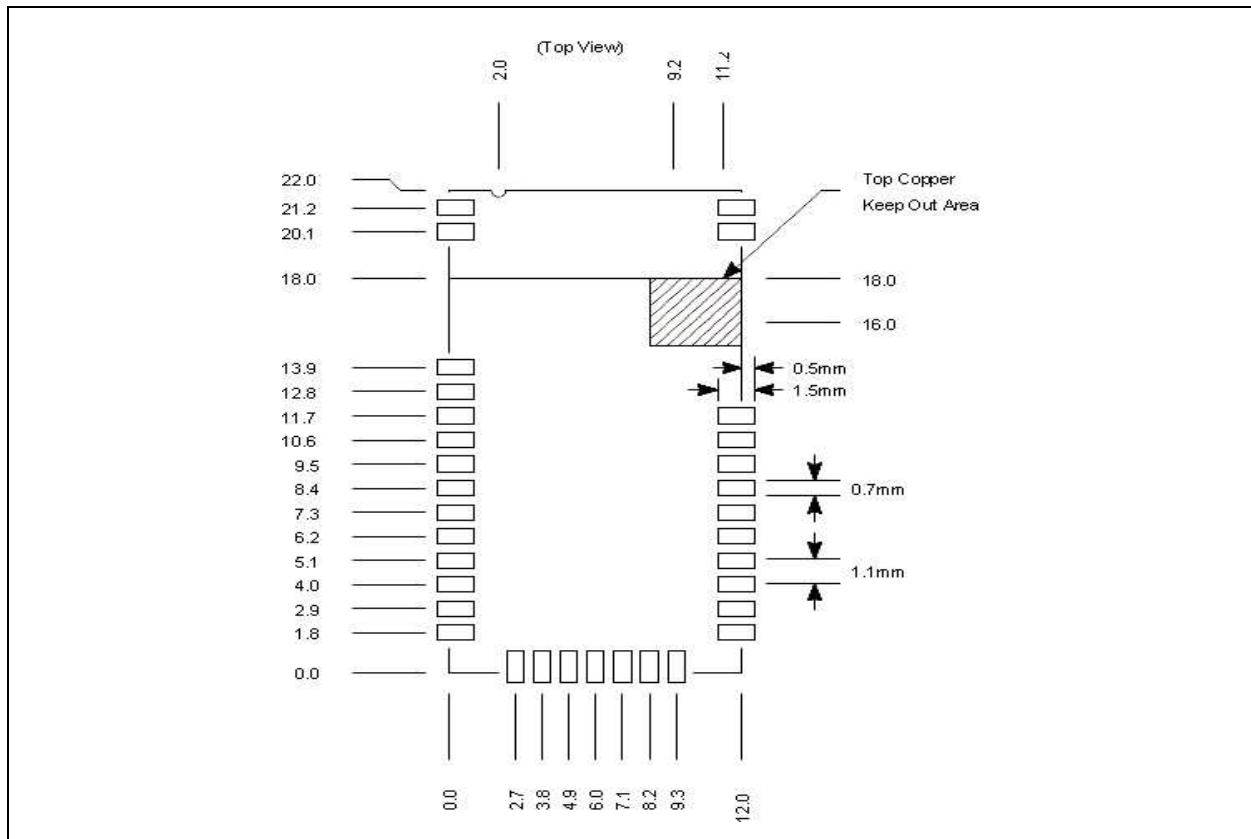
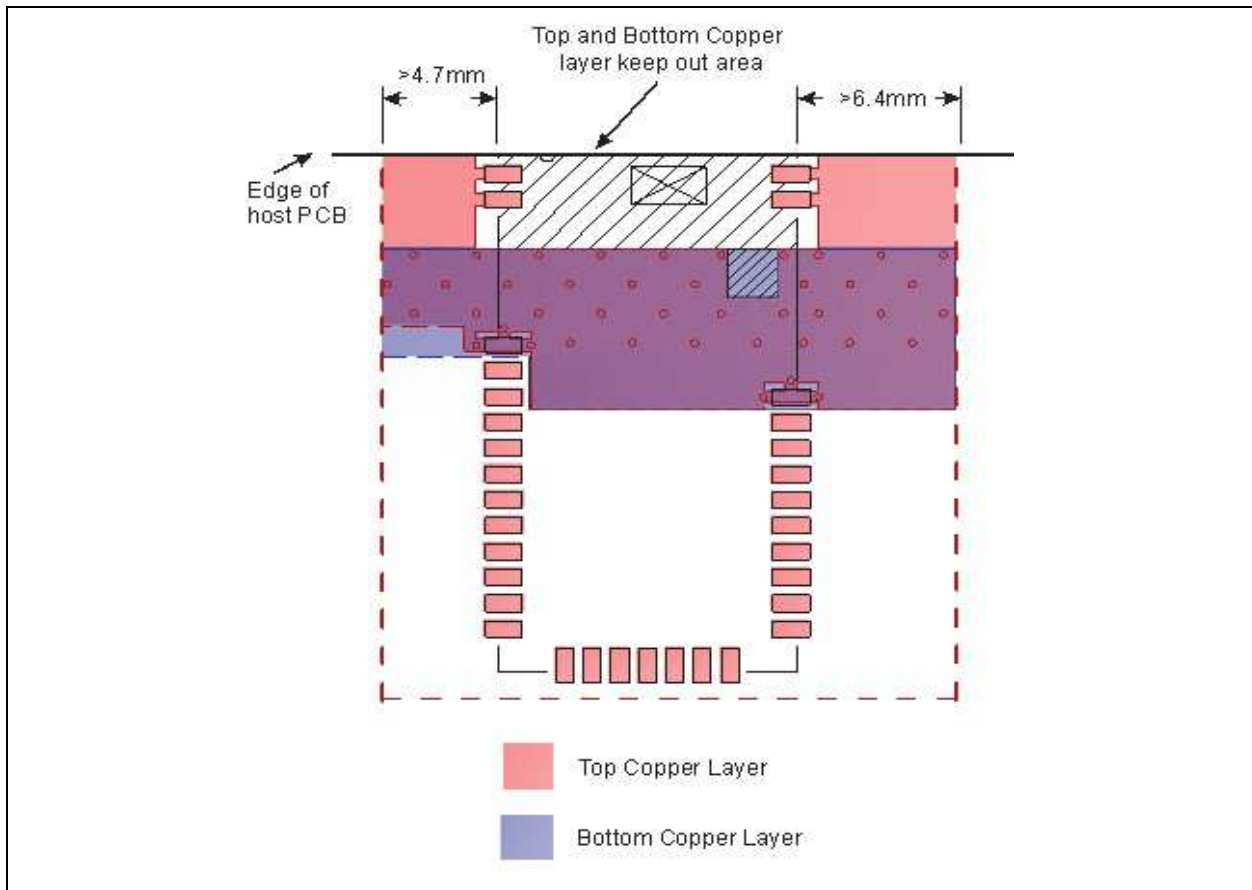

Figure 6-3 illustrates the recommendations for mounting the BM78SPPS5MC2/NC2 on the host PCB, and it also shows the minimum ground plane area to the left and right of the module for the best antenna performance.

recommended as needed for host PCB EMC noise reduction. For best range performance, keep all external metal at least 31 mm away from the ceramic chip antenna.

Avoid top copper layer near the test pin area. When designing the host PCB, the areas under the antenna should not contain any top, inner, or bottom copper layer. A low-impedance ground plane will ensure best radio performance (best range and lowest noise). The ground plane can be extended beyond the minimum

**FIGURE 6-3: BM78SPPS5MC2/NC2 HOST PCB MOUNTING SUGGESTION**



# BM78

Figure 6-4 illustrates the physical dimensions of the BM78SPP05MC2/NC2 module.

**FIGURE 6-4: BM78SPP05MC2/NC2 MODULE DIMENSIONS**

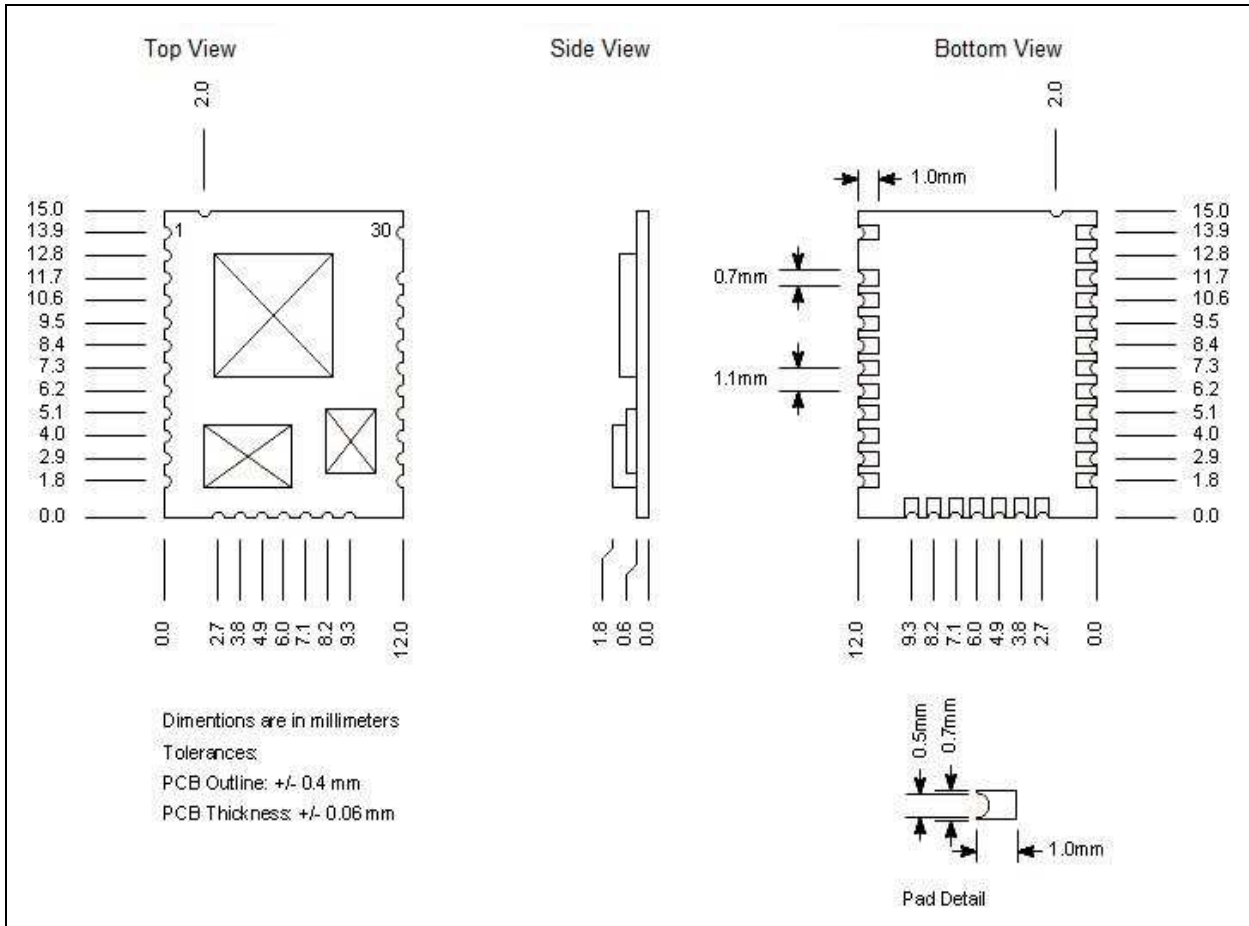
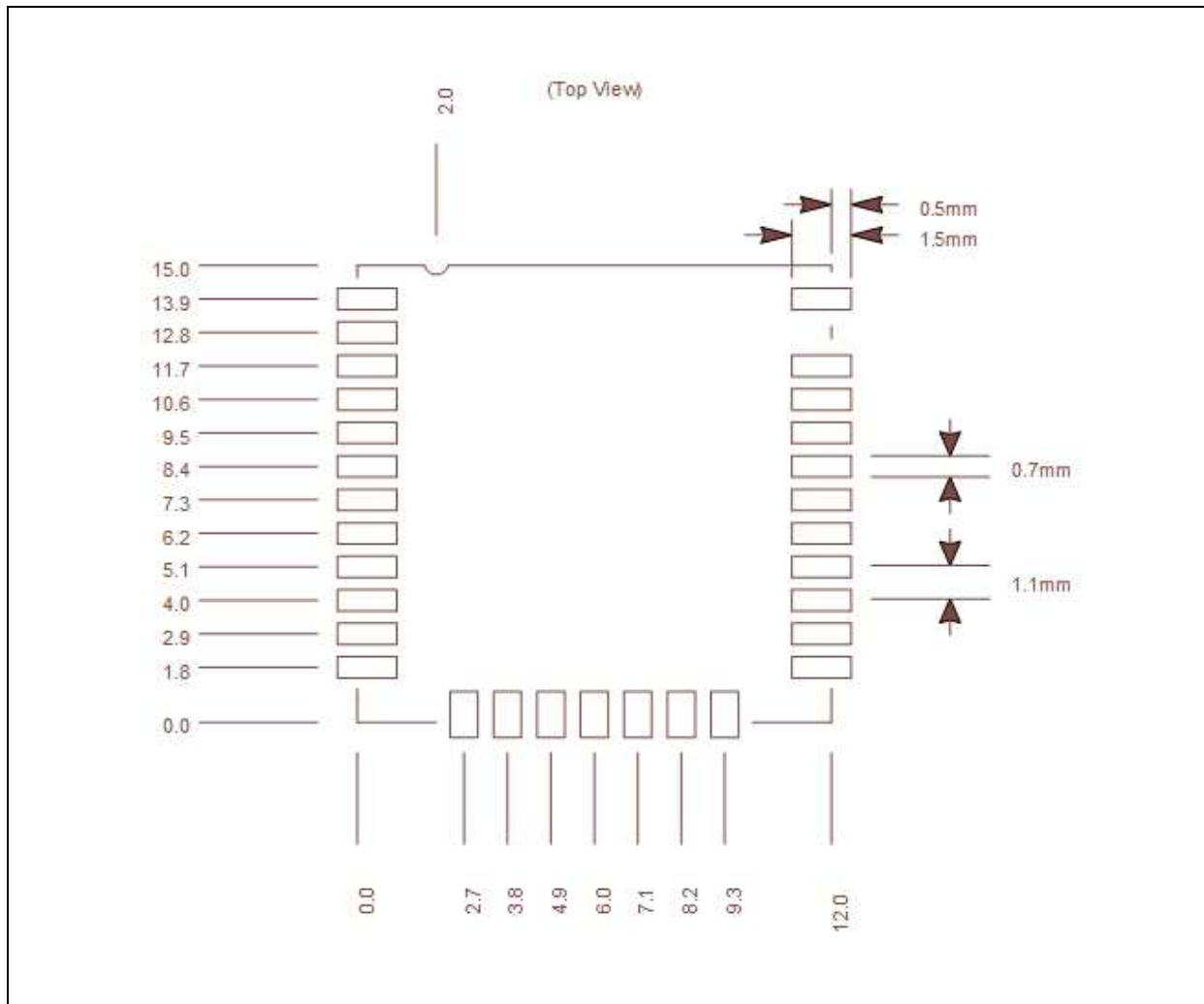



Figure 6-5 illustrates the recommended host PCB foot print.

**FIGURE 6-5: BM78SPP05MC2/NC2 RECOMMENDED PCB FOOTPRINT**



# BM78

Figure 6-6 illustrates the recommended mounting details for the BM78SPP05MC2/NC2 module and recommended layout of the host PCB.

A low-impedance ground plane will ensure best radio performance (best range, lowest noise). Pin30 (BT\_RF) is a 50 ohm connection to an external antenna connector, PCB trace antenna, or component (ceramic chip) antenna through a host PCB with 50 ohm impedance and micro-strip trace. This trace can be extended to include passive parts for antenna attenuation padding, impedance matching, or to provide test posts. It is recommended that the micro-strip trace be as short as

possible for minimum loss and better impedance matching. If the micro-strip trace is longer, it should be a 50 ohm impedance.

**FIGURE 6-6: BM78SPP05MC2/NC2 HOST PCB MOUNTING SUGGESTION**

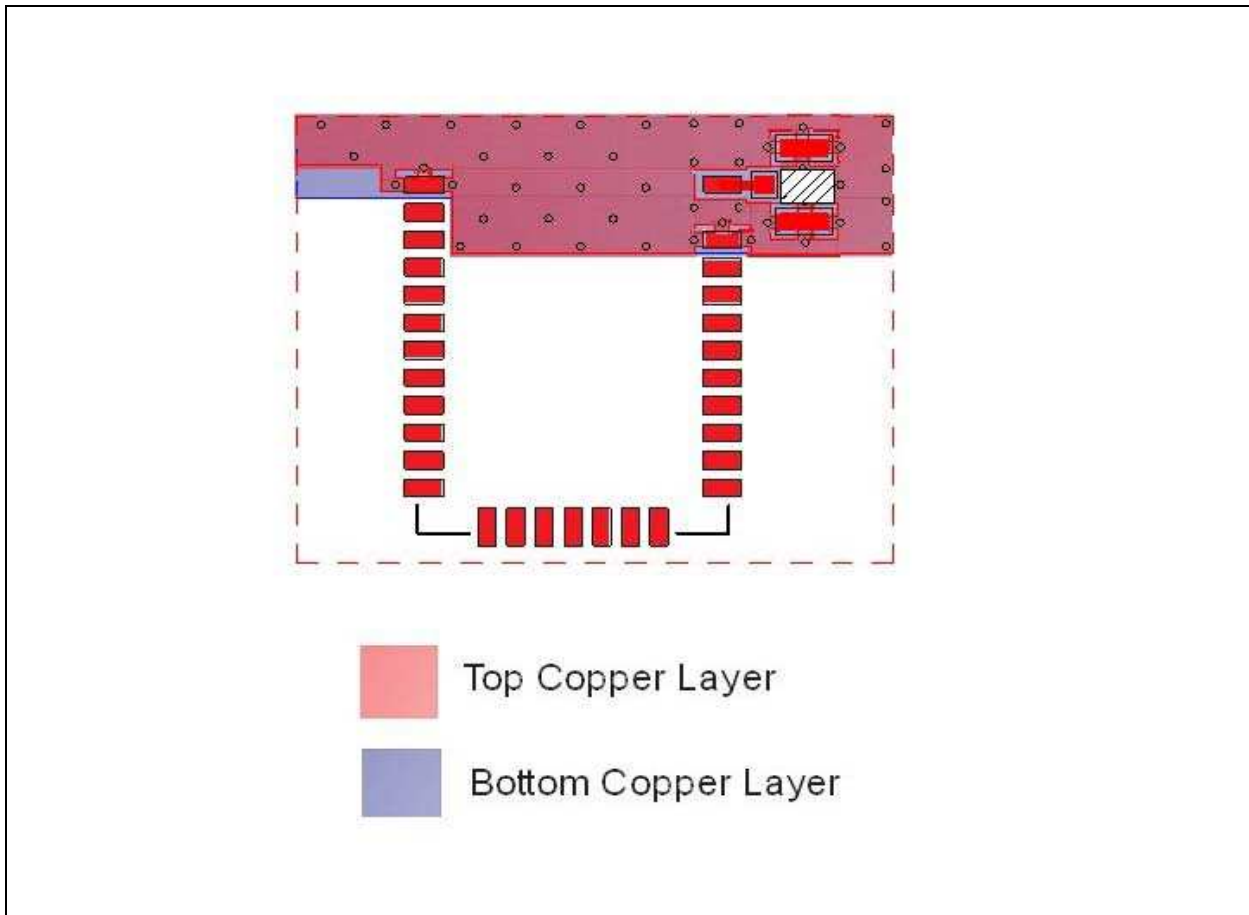

## 7.0 REFLOW PROFILE

The BM78 should be assembled using a standard lead-free reflow profile, IPC/JEDEC J-STD-020. The BM78 can be soldered to the host PCB by using the standard leaded and lead-free solder reflow profile.

To avoid damage to the module, follow these recommendations:

- Follow solder reflow recommendations provided in Microchip Technology Application Note “AN233 Solder Reflow Recommendation (DS00233)”.
- Refer to the solder paste data sheet for specific reflow profile recommendations.
- Do not exceed the peak temperature ( $T_P$ ) of 250°C.
- Use no-clean flux solder paste.
- Do not wash as moisture can be trapped under the shield.
- Use only one flow. If the PCB requires multiple

flows, apply the module on the final flow.

- Standard: IPC/JEDEC J-STD-020.
  - Condition: Preheat: 150~200 °C for 60~120 seconds.
  - Average ramp-up rate (217 °C to peak): 3 °C/sec max.
  - Temperature maintained above 217: 60~150 seconds.
  - Time within 5°C of peak temperature: 30 ~ 40 seconds.
  - Peak temperature: 260 +5/-0 °C .
  - Ramp-down rate (peak to 217): 6 °C /sec. max.
  - Time 25 °C to peak temperature: 8 minutes max.
  - Cycle interval 5 minutes.

**FIGURE 7-1: REFLOW PROFILE**

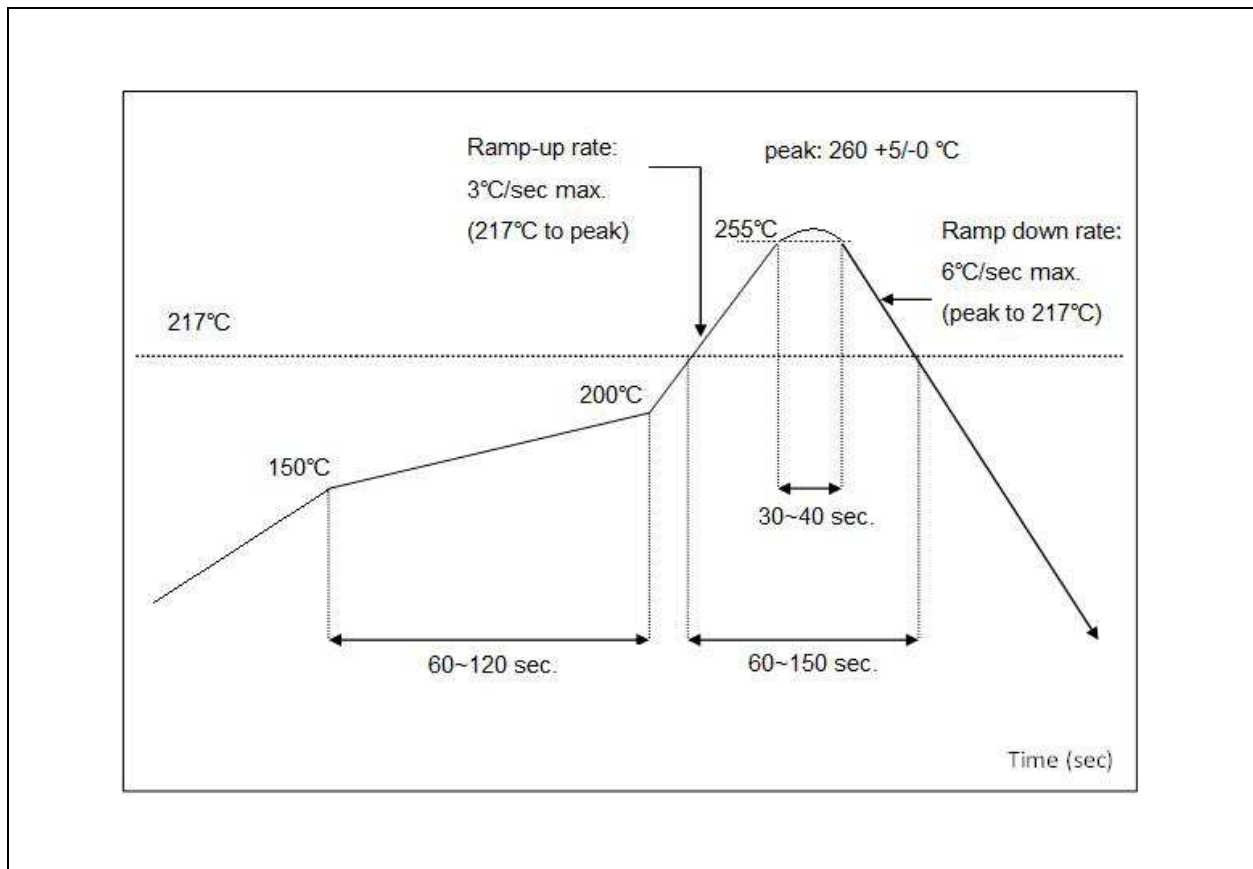

# BM78

---

NOTES:

## 8.0 MODULE PLACEMENT

For a Bluetooth wireless product, the antenna placement affects the performance of the whole system. The antenna requires free space to radiate the RF signal and it cannot be surrounded by the ground plane. Microchip recommends that the areas underneath the antenna on the host PCB should not contain copper on top, inner, or bottom layer.

The ground plane can be extended beyond the minimum recommended as required for the main PCB EMC noise reduction. For the best range performance, keep all external metal away from the ceramic chip antenna, that is minimum 15 mm away.

Figure 8-1 illustrates an example of good and poor antenna placement on a host PCB with ground plane.

**FIGURE 8-1: MODULE PLACEMENT EXAMPLES**

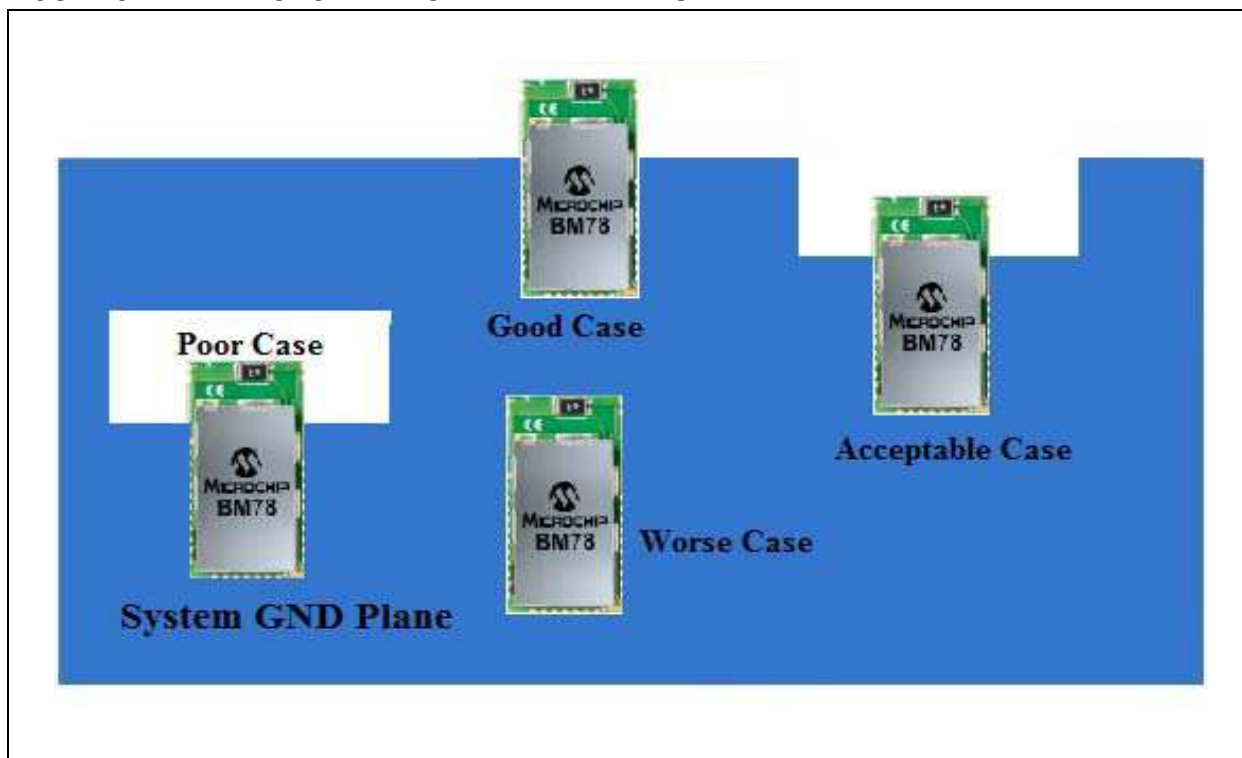

**TABLE 8-1: RECOMMENDED ANTENNA**

Description	Manufacturer Part Number	Manufacturer
ANT ANT3216A063R2400A PIFA 2.4GHZ L3.2W1.6	ANT3216A063R2400A	YAGEO

# BM78

Figure 8-2 illustrates the BM78 module is mounted on the BM78 Evaluation Board (EVB). It also shows the recommended keep out area for the antenna.

**FIGURE 8-2: KEEP OUT AREA RECOMMENDED FOR ANTENNA**

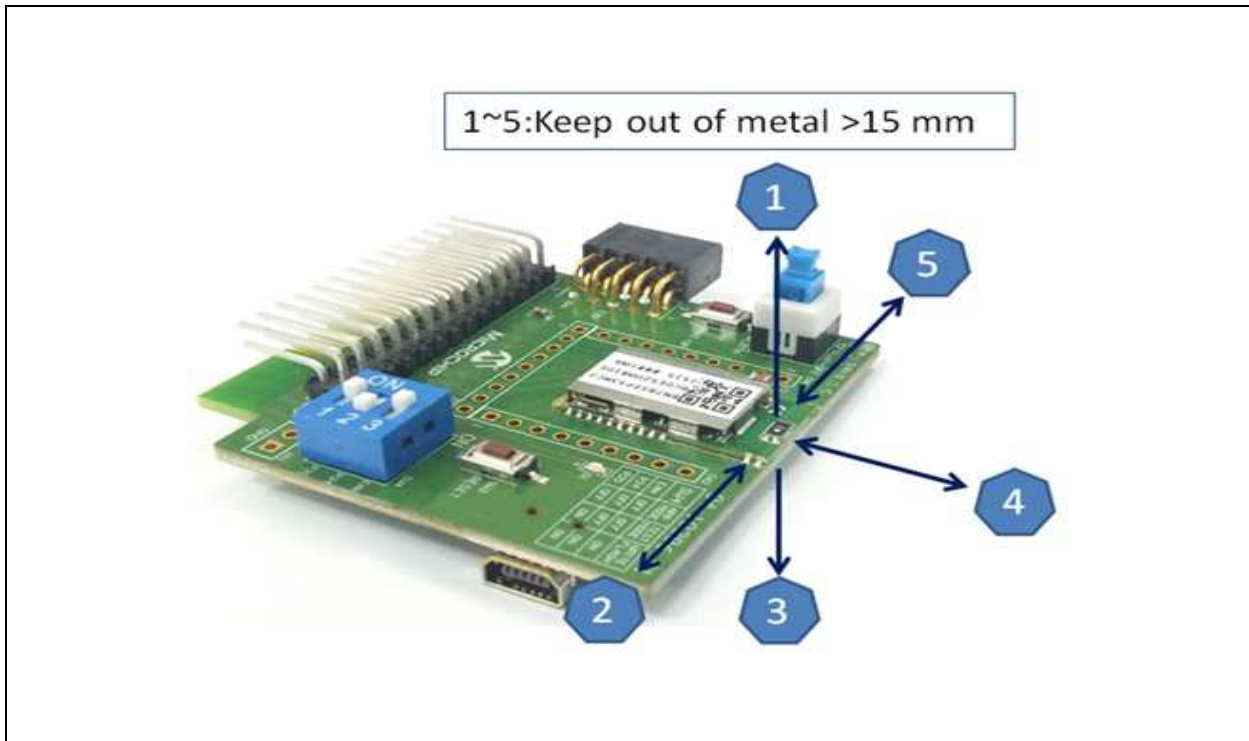

**Note:** For additional information on free space for antenna placement design, refer to the design rule document of the antenna manufacturer.

## 8.1 BM78SPPS5MC2/NC2 Ceramic Chip Antenna

The BM78SPPS5MC2/NC2 contains an integral ceramic chip antenna. Figure 8-3 illustrates the antenna radiation pattern of the ceramic chip antenna on the BM78SPPS5MC2/NC2.

**FIGURE 8-3: BM78SPPS5MC2/NC2 ANTENNA RADIATION PATTERN**

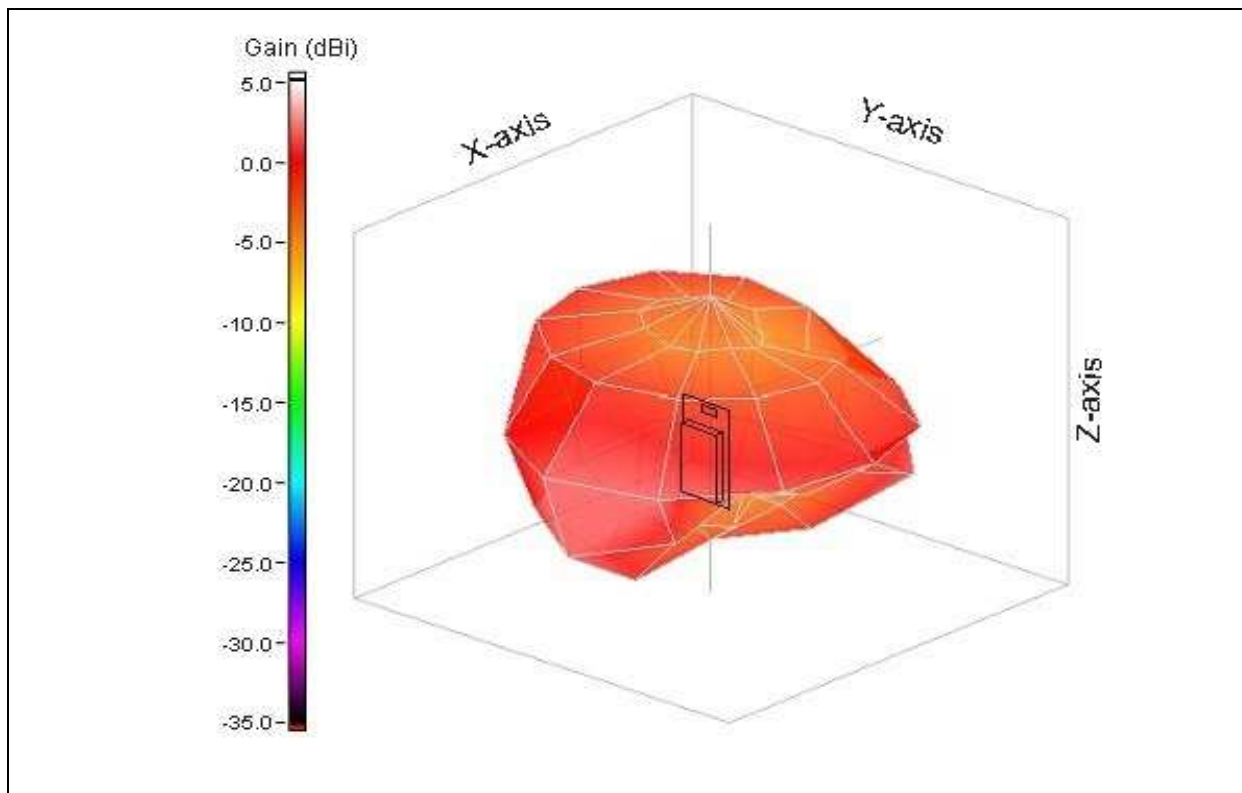

**TABLE 8-2: ANTENNA RADIATION PATTERN DETAILS**

Parameter	Values
Frequency	2450 MHz
Peak Gain	1.63 dBi
Efficiency	71.55%

# BM78

---

NOTES:



## 9.0 ORDERING INFORMATION

Table 9-1 provides the various SKUs of the BM78 module.

**TABLE 9-1: BM78 MODULE SKUS**

Device	Microchip IC	Antenna	Description	Shield	Regulatory Certification	Ordering Number
BM78SPPS5MC2	IS1678SM-151	On-board	BT4.2 Dual Mode, Class 2, Flash Variant	Yes	FCC, IC, CE, MIC, KCC, NCC, JRF	BM78SPPS5MC2-0002AA
BM78SPP05MC2	IS1678SM-151	External	BT4.2 Dual Mode, Class 2, Flash Variant	No	No	BM78SPP05MC2-0002AA
BM78SPPS5NC2	IS1678S-152	On-board	BT4.2 Dual Mode, Class 2, ROM Variant	Yes	Planned	BM78SPPS5NC2-0002AA
BM78SPP05NC2	IS1678S-152	External	BT4.2 Dual Mode, Class 2, ROM Variant	No	No	BM78SPP05NC2-0002AA

**Note:** Contact Microchip Sales office for information on Bluetooth 4.2 ROM variants of the BM78.

# BM78

---

NOTES:

## APPENDIX A: CERTIFICATION NOTICES

The BM78 has received regulatory approval for the following countries:

- BT SIG/QDID: 75929
- United States/FCC ID: A8TBM78ABCDEFGH
- Canada:
  - IC ID: 12246A-BM78SPPS5M2
  - HVIN: BM78SPPS5M2
- Europe/CE
- Japan/MIC: 202-SMD070
- Korea/KCC: MSIP-CRM-mcp-BM78SPPS5MC2
- Taiwan/NCC No: CCAN15LP0510T4

### A.1 REGULATORY APPROVAL

This section outlines the regulatory information for the BM78 for the following countries:

- United States
- Canada
- Europe
- Japan
- Korea
- Taiwan
- Other Regulatory Jurisdictions

#### A.1.1 UNITED STATES

The BM78 module has received Federal Communications Commission (FCC) CFR47 Telecommunications, Part 15 Subpart C "Intentional Radiators" modular approval in accordance with Part 15.212 Modular Transmitter approval. Modular approval allows the end user to integrate the BM78 module into a finished product without obtaining subsequent and separate FCC approvals for intentional radiation, provided no changes or modifications are made to the module circuitry. Changes or modifications could void the user's authority to operate the equipment. The end user must comply with all of the instructions provided by the Grantee, which indicate installation and/or operating conditions necessary for compliance.

The finished product is required to comply with all applicable FCC equipment authorizations regulations, requirements and equipment functions not associated with the transmitter module portion. For example, compliance must be demonstrated to regulations for other transmitter components within the host product. The requirements for unintentional radiators (Part 15 Subpart B "Unintentional Radiators"), such as digital devices, computer peripherals, radio receivers, etc.; and to additional authorization requirements for the non-transmitter functions on the transmitter module (i.e., Verification, or Declaration of Conformity) (e.g., transmitter modules may also contain digital logic functions) as appropriate.

#### A.1.2 LABELING AND USER INFORMATION REQUIREMENTS

The BM78 has been labeled with its own FCC ID number, and if the FCC ID is not visible when the module is installed inside another device, then the outside of the finished product into which the module is installed must also display a label referring to the enclosed module. This exterior label can use wording as follows:

Contains Transmitter Module FCC ID: A8TBM78AB-CDEFGH

or

Contains FCC ID:A8TBM78ABCDEFGH

This device complies with Part 15 of the FCC Rules. Operation is subject to the following two conditions: (1) this device may not cause harmful interference, and (2) this device must accept any interference received, including interference that may cause undesired operation

A user's manual for the finished product should include the following statement:

This equipment has been tested and found to comply with the limits for a Class B digital device, pursuant to part 15 of the FCC Rules. These limits are designed to provide reasonable protection against harmful interference in a residential installation. This equipment generates, uses and can radiate radio frequency energy, and if not installed and used in accordance with the instructions, may cause harmful interference to radio communications. However, there is no guarantee that interference will not occur in a particular installation. If this equipment does cause harmful interference to radio or television reception, which can be determined by turning the equipment off and on, the user is encouraged to try to correct the interference by one or more of the following measures:

- Reorient or relocate the receiving antenna.
- Increase the separation between the equipment and receiver.
- Connect the equipment into an outlet on a circuit different from that to which the receiver is connected.
- Consult the dealer or an experienced radio/TV technician for help.

Additional information on labeling and user information requirements for Part 15 devices can be found in KDB Publication 784748 available at the FCC Office of Engineering and Technology (OET) Laboratory Division Knowledge Database (KDB)  
<http://apps.fcc.gov/oetcf/kdb/index.cfm>.

# BM78

## A.1.3 RF EXPOSURE

All transmitters regulated by FCC must comply with RF exposure requirements. KDB 447498 General RF Exposure Guidance provides guidance in determining whether proposed or existing transmitting facilities, operations or devices comply with limits for human exposure to Radio Frequency (RF) fields adopted by the Federal Communications Commission (FCC).

From the FCC Grant: Output power listed is conducted. This grant is valid only when the module is sold to OEM integrators and must be installed by the OEM or OEM integrators. This transmitter is restricted for use with the specific antenna(s) tested in this application for Certification and must not be co-located or operating in conjunction with any other antenna or transmitters within a host device, except in accordance with FCC multi-transmitter product procedures.

## A.1.4 HELPFUL WEB SITES

Federal Communications Commission (FCC): <http://www.fcc.gov>.

FCC Office of Engineering and Technology (OET) Laboratory Division Knowledge Database (KDB): <http://apps.fcc.gov/oetcf/kdb/index.cfm>.

## A.2 Canada

The BM78 module has been certified for use in Canada under Industry Canada (IC) Radio Standards Specification (RSS) RSS-247 and RSS-Gen. Modular approval permits the installation of a module in a host device without the need to recertify the device.

### A.2.1 LABELING AND USER INFORMATION REQUIREMENTS

Labeling Requirements for the host device (from Section 3.1, RSS-Gen, Issue 4, November 2014): The host device shall be properly labeled to identify the module within the host device.

The Industry Canada certification label of a module shall be clearly visible at all times when installed in the host device, otherwise the host device must be labeled to display the Industry Canada certification number of the module, preceded by the words "Contains transmitter module", or the word "Contains", or similar wording expressing the same meaning, as follows:

Contains transmitter module IC:  
12246A-BM78SPPS5M2

User Manual Notice for License-Exempt Radio Apparatus (from Section 8.4 RSS-Gen, Issue 4, November 2014): User manuals for license-exempt radio apparatus

shall contain the following or equivalent notice in a conspicuous location in the user manual or alternatively on the device or both:

This device complies with Industry Canada license-exempt RSS standard(s). Operation is subject to the following two conditions: (1) this device may not cause interference, and (2) this device must accept any interference, including interference that may cause undesired operation of the device.

Le présent appareil est conforme aux CNR d'Industrie Canada applicables aux appareils radio exempts de licence. L'exploitation est autorisée aux deux conditions suivantes: (1) l'appareil ne doit pas produire de brouillage, et (2) l'utilisateur de l'appareil doit accepter tout brouillage radioélectrique subi, même si le brouillage est susceptible d'en compromettre le fonctionnement.

Transmitter Antenna (from Section 8.3 RSS-Gen, Issue 4, November 2014): User manuals for transmitters shall display the following notice in a conspicuous location:

Under Industry Canada regulations, this radio transmitter may only operate using an antenna of a type and maximum (or lesser) gain approved for the transmitter by Industry Canada. To reduce potential radio interference to other users, the antenna type and its gain should be so chosen that the equivalent isotropically radiated power (e.i.r.p.) is not more than that necessary for successful communication.

Conformément à la réglementation d'Industrie Canada, le présent émetteur radio peut fonctionner avec une antenne d'un type et d'un gain maximal (ou inférieur) approuvé pour l'émetteur par Industrie Canada. Dans le but de réduire les risques de brouillage radioélectrique à l'intention des autres utilisateurs, il faut choisir le type d'antenne et son gain de sorte que la puissance isotrope rayonnée équivalente (p.i.r.e.) ne dépasse pas l'intensité nécessaire à l'établissement d'une communication satisfaisante.

The above notice may be affixed to the device instead of displayed in the user manual.

### A.2.2 RF EXPOSURE

All transmitters regulated by IC must comply with RF exposure requirements listed in RSS-102 - Radio Frequency (RF) Exposure Compliance of Radiocommunication Apparatus (All Frequency Bands).

### A.2.3 HELPFUL WEB SITES

Industry Canada: <http://www.ic.gc.ca/>

## A.3 Europe

The BM78 module is an R&TTE Directive assessed radio module that is CE marked and has been manufactured and tested with the intention of being integrated into a final product.

The BM78 module has been tested to R&TTE Directive 1999/5/EC Essential Requirements for Health and Safety (Article (3.1(a)), Electromagnetic Compatibility (EMC) (Article 3.1(b)), and Radio (Article 3.2) and are summarized in **Section TABLE A-1: “EUROPEAN COMPLIANCE TESTING”**. A notified body opinion has also been issued.

The R&TTE Compliance Association provides guidance on modular devices in document Technical Guidance Note 01 available at [http://www.rtteca.com/html/download\\_area.htm](http://www.rtteca.com/html/download_area.htm).

**Note:** To maintain conformance to the testing listed in **Section TABLE A-1: “EUROPEAN COMPLIANCE TESTING”**, the module shall be installed in accordance with the installation instructions in this data sheet and shall not be modified. When integrating a radio module into a completed product the integrator becomes the manufacturer of the final product and is therefore responsible for demonstrating compliance of the final product with the essential requirements of the R&TTE Directive.

### A.3.2 ANTENNA REQUIREMENTS

From R&TTE Compliance Association document Technical Guidance Note 01:

Provided the integrator installing an assessed radio module with an integral or specific antenna and installed in conformance with the radio module manufacturer's installation instructions requires no further evaluation under Article 3.2 of the R&TTE Directive and does not require further involvement of an R&TTE Directive Notified Body for the final product. [Section 2.2.4]

The European Compliance Testing listed in **Section TABLE A-1: “EUROPEAN COMPLIANCE TESTING”** was performed using the integral ceramic chip antenna.

### A.3.1 LABELING AND USER INFORMATION REQUIREMENTS

The label on the final product which contains the BM78 module must follow CE marking requirements. The R&TTE Compliance Association Technical Guidance Note 01 provides guidance on final product CE marking.

**TABLE A-1: EUROPEAN COMPLIANCE TESTING**

Certification	Standards	Article	Laboratory	Report Number
Safety	EN 60950-1:2006+A11:2009 +A1:2010 +A12:2011+A2:2013	[3.1(a)]	TUV Rheinland	10052799 001
Health	ETSI EN 300 328 V1.9.1 EN 62479:2010			10052796 001 10052797 001
EMC	EN 300 489-1 V1.9.2 EN 301 489-17 V2.2.1	[3.1(b)]		10052437 001
Radio	ETSI EN 300 328 V1.9.1	(3.2)		10052796 001 10052797 001
Notified Body Opinion	<b>CE 0197</b>	—	TUV Rheinland	10048937 001

## A.3.3 HELPFUL WEBSITES

A document that can be used as a starting point in understanding the use of Short Range Devices (SRD) in Europe is the European Radio Communications Committee (ERC) Recommendation 70-03 E, which can be downloaded from the European Radio Communications Office (ERO) at: <http://www.ero.dk/>.

Additional helpful web sites are:

- Radio and Telecommunications Terminal Equipment (R&TTE):  
[http://ec.europa.eu/enterprise/rtte/index\\_en.htm](http://ec.europa.eu/enterprise/rtte/index_en.htm)
- European Conference of Postal and Telecommunications Administrations (CEPT):  
<http://www.cept.org>
- European Telecommunications Standards Institute (ETSI):  
<http://www.etsi.org>
- European Radio Communications Office (ERO):  
<http://www.ero.dk>
- The Radio and Telecommunications Terminal Equipment Compliance Association (R&TTE CA):  
<http://www.rtteca.com/>

## A.4 Japan

The BM78 module has received type certification and is labeled with its own technical conformity mark and certification number as required to conform to the technical standards regulated by the Ministry of Internal Affairs and Communications (MIC) of Japan pursuant to the Radio Act of Japan.

Integration of this module into a final product does not require additional radio certification provided installation instructions are followed and no modifications of the module are allowed. Additional testing may be required:

- If the host product is subject to electrical appliance safety (for example, powered from an AC mains), the host product may require Product Safety Electrical Appliance and Material (PSE) testing. The integrator should contact their conformance laboratory to determine if this testing is required.
- There is an voluntary Electromagnetic Compatibility (EMC) test for the host product administered by VCCI: [http://www.vcci.jp/vcci\\_e/index.html](http://www.vcci.jp/vcci_e/index.html)

### A.4.1 LABELING AND USER INFORMATION REQUIREMENTS

The label on the final product which contains the BM78 module must follow Japan marking requirements. The integrator of the module should refer to the labeling requirements for Japan available at the Ministry of Internal Affairs and Communications (MIC) website.

The BM78 module is labeled with its own technical conformity mark and certification number. The final product in which this module is being used must have a label referring to the type certified module inside:



## A.4.2 HELPFUL WEB SITES

Ministry of Internal Affairs and Communications (MIC):  
<http://www.tele.soumu.go.jp/e/index.htm>

Association of Radio Industries and Businesses (ARIB): <http://www.arib.or.jp/english/>

## A.5 Korea

The BM78 module has received certification of conformity in accordance with the Radio Waves Act. Integration of this module into a final product does not require additional radio certification provided installation instructions are followed and no modifications of the module are allowed.

### A.5.1 LABELING AND USER INFORMATION REQUIREMENTS

The label on the final product which contains the BM78 module must follow KC marking requirements. The integrator of the module should refer to the labeling requirements for Korea available on the Korea Communications Commission (KCC) website.

The BM78 module is labeled with its own KC mark. The final product requires the KC mark and certificate number of the module:

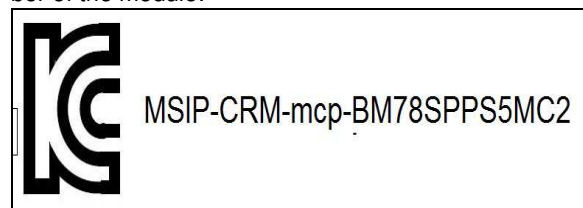

## A.5.2 HELPFUL WEB SITES

Korea Communications Commission (KCC):  
<http://www.kcc.go.kr>

National Radio Research Agency (RRA):  
<http://rra.go.kr>

## A.6 Taiwan

The BM78 module has received compliance approval in accordance with the Telecommunications Act. Customers seeking to use the compliance approval in their product should contact Microchip Technology sales or distribution partners to obtain a Letter of Authority.

Integration of this module into a final product does not require additional radio certification provided installation instructions are followed and no modifications of the module are allowed.

### A.6.1 LABELING AND USER INFORMATION REQUIREMENTS

The **BM78** module is labeled with its own NCC mark and certificate number as below:

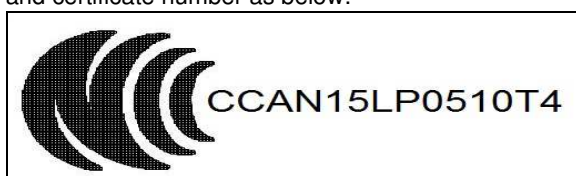

The user's manual should contain below warning (for RF device) in traditional Chinese:

注意！

依據 低功率電波輻射性電機管理辦法

第十二條 經型式認證合格之低功率射頻電機，非經許可，

公司、商號或使用者均不得擅自變更頻率、加大功率或變更原設計

之特性及功能。

第十四條 低功率射頻電機之使用不得影響飛航安全及干擾合法通信；

經發現有干擾現象時，應立即停用，並改善至無干擾時方得繼續使用。

前項合法通信，指依電信規定作業之無線電信。

低功率射頻電機須忍受合法通信或工業、科學及醫療用電波輻射性

電機設備之干擾。

### A.6.2 HELPFUL WEB SITES

National Communications Commission (NCC):  
<http://www.ncc.gov.tw>

## A.7 Other Regulatory Jurisdictions

Should other regulatory jurisdiction certification be required by the customer, or the customer need to recertify the module for other reasons, please contact Microchip for the required utilities and documentation.

## APPENDIX B: REVISION HISTORY

### Revision A (January 2016)

This is the initial released version of this document.



## THE MICROCHIP WEB SITE

Microchip provides online support via our WWW site at [www.microchip.com](http://www.microchip.com). This web site is used as a means to make files and information easily available to customers. Accessible by using your favorite Internet browser, the web site contains the following information:

- **Product Support** – Data sheets and errata, application notes and sample programs, design resources, user’s guides and hardware support documents, latest software releases and archived software
- **General Technical Support** – Frequently Asked Questions (FAQ), technical support requests, online discussion groups, Microchip consultant program member listing
- **Business of Microchip** – Product selector and ordering guides, latest Microchip press releases, listing of seminars and events, listings of Microchip sales offices, distributors and factory representatives

## CUSTOMER CHANGE NOTIFICATION SERVICE

Microchip’s customer notification service helps keep customers current on Microchip products. Subscribers will receive e-mail notification whenever there are changes, updates, revisions or errata related to a specified product family or development tool of interest.

To register, access the Microchip web site at [www.microchip.com](http://www.microchip.com). Under “Support”, click on “Customer Change Notification” and follow the registration instructions.

## CUSTOMER SUPPORT

Users of Microchip products can receive assistance through several channels:

- Distributor or Representative
- Local Sales Office
- Field Application Engineer (FAE)
- Technical Support

Customers should contact their distributor, representative or Field Application Engineer (FAE) for support. Local sales offices are also available to help customers. A listing of sales offices and locations is included in the back of this document.

**Technical support is available through the web site at: <http://microchip.com/support>**

# BM78

---

NOTES:

---

**Note the following details of the code protection feature on Microchip devices:**

- Microchip products meet the specification contained in their particular Microchip Data Sheet.
- Microchip believes that its family of products is one of the most secure families of its kind on the market today, when used in the intended manner and under normal conditions.
- There are dishonest and possibly illegal methods used to breach the code protection feature. All of these methods, to our knowledge, require using the Microchip products in a manner outside the operating specifications contained in Microchip's Data Sheets. Most likely, the person doing so is engaged in theft of intellectual property.
- Microchip is willing to work with the customer who is concerned about the integrity of their code.
- Neither Microchip nor any other semiconductor manufacturer can guarantee the security of their code. Code protection does not mean that we are guaranteeing the product as "unbreakable."

Code protection is constantly evolving. We at Microchip are committed to continuously improving the code protection features of our products. Attempts to break Microchip's code protection feature may be a violation of the Digital Millennium Copyright Act. If such acts allow unauthorized access to your software or other copyrighted work, you may have a right to sue for relief under that Act.

---

Information contained in this publication regarding device applications and the like is provided only for your convenience and may be superseded by updates. It is your responsibility to ensure that your application meets with your specifications. MICROCHIP MAKES NO REPRESENTATIONS OR WARRANTIES OF ANY KIND WHETHER EXPRESS OR IMPLIED, WRITTEN OR ORAL, STATUTORY OR OTHERWISE, RELATED TO THE INFORMATION, INCLUDING BUT NOT LIMITED TO ITS CONDITION, QUALITY, PERFORMANCE, MERCHANTABILITY OR FITNESS FOR PURPOSE. Microchip disclaims all liability arising from this information and its use. Use of Microchip devices in life support and/or safety applications is entirely at the buyer's risk, and the buyer agrees to defend, indemnify and hold harmless Microchip from any and all damages, claims, suits, or expenses resulting from such use. No licenses are conveyed, implicitly or otherwise, under any Microchip intellectual property rights unless otherwise stated.

**Trademarks**

The Microchip name and logo, the Microchip logo, dsPIC, FlashFlex, flexPWR, JukeBlox, KEELOQ, KEELOQ logo, Kleer, LANCheck, MediaLB, MOST, MOST logo, MPLAB, OptoLyzer, PIC, PICSTART, PIC<sup>32</sup> logo, RightTouch, SpyNIC, SST, SST Logo, SuperFlash and UNI/O are registered trademarks of Microchip Technology Incorporated in the U.S.A. and other countries.

The Embedded Control Solutions Company and mTouch are registered trademarks of Microchip Technology Incorporated in the U.S.A.

Analog-for-the-Digital Age, BodyCom, chipKIT, chipKIT logo, CodeGuard, dsPICDEM, dsPICDEM.net, ECAN, In-Circuit Serial Programming, ICSP, Inter-Chip Connectivity, KleerNet, KleerNet logo, MiWi, motorBench, MPASM, MPF, MPLAB Certified logo, MPLIB, MPLINK, MultiTRAK, NetDetach, Omniscient Code Generation, PICDEM, PICDEM.net, PICkit, PICtail, RightTouch logo, REAL ICE, SQI, Serial Quad I/O, Total Endurance, TSHARC, USBCheck, VariSense, ViewSpan, WiperLock, Wireless DNA, and ZENA are trademarks of Microchip Technology Incorporated in the U.S.A. and other countries.

SQTP is a service mark of Microchip Technology Incorporated in the U.S.A.

Silicon Storage Technology is a registered trademark of Microchip Technology Inc. in other countries.

GestIC is a registered trademark of Microchip Technology Germany II GmbH & Co. KG, a subsidiary of Microchip Technology Inc., in other countries.

All other trademarks mentioned herein are property of their respective companies.

© 2016, Microchip Technology Incorporated, Printed in the U.S.A., All Rights Reserved.

ISBN: 978-1-5224-0133-9

**QUALITY MANAGEMENT SYSTEM  
CERTIFIED BY DNV  
= ISO/TS 16949 =**

*Microchip received ISO/TS-16949:2009 certification for its worldwide headquarters, design and wafer fabrication facilities in Chandler and Tempe, Arizona; Gresham, Oregon and design centers in California and India. The Company's quality system processes and procedures are for its PIC<sup>®</sup> MCUs and dsPIC<sup>®</sup> DSCs, KEELOQ<sup>®</sup> code hopping devices, Serial EEPROMs, microperipherals, nonvolatile memory and analog products. In addition, Microchip's quality system for the design and manufacture of development systems is ISO 9001:2000 certified.*



# MICROCHIP

## Worldwide Sales and Service

### AMERICAS

**Corporate Office**  
2355 West Chandler Blvd.  
Chandler, AZ 85224-6199  
Tel: 480-792-7200  
Fax: 480-792-7277  
Technical Support:  
<http://www.microchip.com/support>  
Web Address:  
[www.microchip.com](http://www.microchip.com)

**Atlanta**  
Duluth, GA  
Tel: 678-957-9614  
Fax: 678-957-1455

**Austin, TX**  
Tel: 512-257-3370

**Boston**  
Westborough, MA  
Tel: 774-760-0087  
Fax: 774-760-0088

**Chicago**  
Itasca, IL  
Tel: 630-285-0071  
Fax: 630-285-0075

**Cleveland**  
Independence, OH  
Tel: 216-447-0464  
Fax: 216-447-0643

**Dallas**  
Addison, TX  
Tel: 972-818-7423  
Fax: 972-818-2924

**Detroit**  
Novi, MI  
Tel: 248-848-4000

**Houston, TX**  
Tel: 281-894-5983

**Indianapolis**  
Noblesville, IN  
Tel: 317-773-8323  
Fax: 317-773-5453

**Los Angeles**  
Mission Viejo, CA  
Tel: 949-462-9523  
Fax: 949-462-9608

**New York, NY**  
Tel: 631-435-6000

**San Jose, CA**  
Tel: 408-735-9110

**Canada - Toronto**  
Tel: 905-673-0699  
Fax: 905-673-6509

### ASIA/PACIFIC

**Asia Pacific Office**  
Suites 3707-14, 37th Floor  
Tower 6, The Gateway  
Harbour City, Kowloon

**Hong Kong**  
Tel: 852-2943-5100  
Fax: 852-2401-3431

**Australia - Sydney**  
Tel: 61-2-9868-6733  
Fax: 61-2-9868-6755

**China - Beijing**  
Tel: 86-10-8569-7000  
Fax: 86-10-8528-2104

**China - Chengdu**  
Tel: 86-28-8665-5511  
Fax: 86-28-8665-7889

**China - Chongqing**  
Tel: 86-23-8980-9588  
Fax: 86-23-8980-9500

**China - Dongguan**  
Tel: 86-769-8702-9880

**China - Hangzhou**  
Tel: 86-571-8792-8115  
Fax: 86-571-8792-8116

**China - Hong Kong SAR**  
Tel: 852-2943-5100  
Fax: 852-2401-3431

**China - Nanjing**  
Tel: 86-25-8473-2460  
Fax: 86-25-8473-2470

**China - Qingdao**  
Tel: 86-532-8502-7355  
Fax: 86-532-8502-7205

**China - Shanghai**  
Tel: 86-21-5407-5533  
Fax: 86-21-5407-5066

**China - Shenyang**  
Tel: 86-24-2334-2829  
Fax: 86-24-2334-2393

**China - Shenzhen**  
Tel: 86-755-8864-2200  
Fax: 86-755-8203-1760

**China - Wuhan**  
Tel: 86-27-5980-5300  
Fax: 86-27-5980-5118

**China - Xian**  
Tel: 86-29-8833-7252  
Fax: 86-29-8833-7256

### ASIA/PACIFIC

**China - Xiamen**  
Tel: 86-592-2388138  
Fax: 86-592-2388130

**China - Zhuhai**  
Tel: 86-756-3210040  
Fax: 86-756-3210049

**India - Bangalore**  
Tel: 91-80-3090-4444  
Fax: 91-80-3090-4123

**India - New Delhi**  
Tel: 91-11-4160-8631  
Fax: 91-11-4160-8632

**India - Pune**  
Tel: 91-20-3019-1500

**Japan - Osaka**  
Tel: 81-6-6152-7160  
Fax: 81-6-6152-9310

**Japan - Tokyo**  
Tel: 81-3-6880-3770  
Fax: 81-3-6880-3771

**Korea - Daegu**  
Tel: 82-53-744-4301  
Fax: 82-53-744-4302

**Korea - Seoul**  
Tel: 82-2-554-7200  
Fax: 82-2-558-5932 or  
82-2-558-5934

**Malaysia - Kuala Lumpur**  
Tel: 60-3-6201-9857  
Fax: 60-3-6201-9859

**Malaysia - Penang**  
Tel: 60-4-227-8870  
Fax: 60-4-227-4068

**Philippines - Manila**  
Tel: 63-2-634-9065  
Fax: 63-2-634-9069

**Singapore**  
Tel: 65-6334-8870  
Fax: 65-6334-8850

**Taiwan - Hsin Chu**  
Tel: 886-3-5778-366  
Fax: 886-3-5770-955

**Taiwan - Kaohsiung**  
Tel: 886-7-213-7828

**Taiwan - Taipei**  
Tel: 886-2-2508-8600  
Fax: 886-2-2508-0102

**Thailand - Bangkok**  
Tel: 66-2-694-1351  
Fax: 66-2-694-1350

### EUROPE

**Austria - Wels**  
Tel: 43-7242-2244-39  
Fax: 43-7242-2244-393

**Denmark - Copenhagen**  
Tel: 45-4450-2828  
Fax: 45-4485-2829

**France - Paris**  
Tel: 33-1-69-53-63-20  
Fax: 33-1-69-30-90-79

**Germany - Dusseldorf**  
Tel: 49-2129-3766400

**Germany - Karlsruhe**  
Tel: 49-721-625370

**Germany - Munich**  
Tel: 49-89-627-144-0  
Fax: 49-89-627-144-44

**Italy - Milan**  
Tel: 39-0331-742611  
Fax: 39-0331-466781

**Italy - Venice**  
Tel: 39-049-7625286

**Netherlands - Druen**  
Tel: 31-416-690399  
Fax: 31-416-690340

**Poland - Warsaw**  
Tel: 48-22-3325737

**Spain - Madrid**  
Tel: 34-91-708-08-90  
Fax: 34-91-708-08-91

**Sweden - Stockholm**  
Tel: 46-8-5090-4654

**UK - Wokingham**  
Tel: 44-118-921-5800  
Fax: 44-118-921-5820

07/14/15