

FEATURES

- Very low profile package
- Ideal for automated placement
- Metal silicon junction ,majority carrier conduction
- Guard ring for overvoltage protection
- Low power loss ,high efficiency
- High current capability ,low forward voltage drop
- High surge capability
- Meets MSL Level 1,per J-STD-020,LF maximum peak of 260°C
- Component in accordance to RoHS 2011/65/EU and WEEE 2012/19/EU



RoHS
COMPLIANT



SOD-123FL

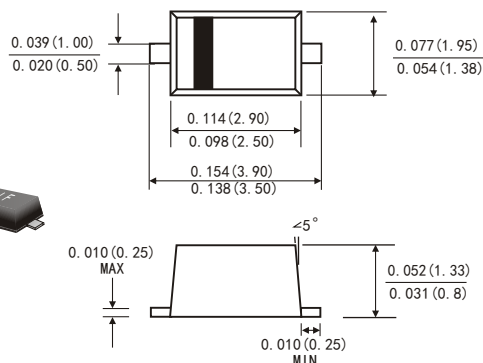

MECHANICAL DATA

- Case: Flat lead SOD-123FL small outline plastic package
- Molding compound meets UL 94 V-0 flammability rating
- Terminals: solderable per J-STD-002 and JESD22-B102
- Polarity: color band denotes cathode end
- Mounting Position: Any
- Weight: 8.85 mg(approximately)

Suggested PAD Layout

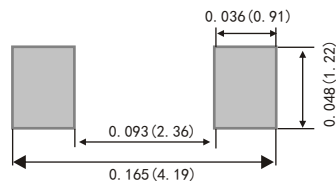

Dimensions in inches and (millimeters)

TYPICAL APPLICATIONS

For use in low voltage ,high frequency inverters ,DC/DC converters, free wheeling ,and polarity protection applications

MAXIMUM RATINGS

(Ratings at 25°C ambient temperature unless otherwise specified)

Parameter	Symbol	L16	Unit
Maximum repetitive peak reverse voltage	V_{RRM}	60	V
Maximum average forward rectified current (see fig.1)	$I_{F(AV)}$	1.0	A
Peak forward surge current 8.3ms single half sine-wave superimposed on rated load (JEDEC method at rated TL)	I_{FSM}	40	A
Operating junction temperature range	T_J	-55 to+150	°C
Storage temperature range	T_{stg}	-55 to+150	°C

RATINGS AND CHARACTERISTIC OF L16

ELECTRICAL CHARACTERISTICS (T_A=25°C Unless otherwise noted)

Parameter	Test Conditions		Symbol	TYP.	MAX.	Unit
Instantaneous forward voltage	I _F =1.0A	T _A =25°C	V _F ¹⁾	0.53	0.55	V
		T _A =100°C		0.47	0.49	
		T _A =125°C		0.45	0.47	
Reverse current	V _R =60V	T _A =25°C	I _R ²⁾	60	150	μA
		T _A =100°C		5	10	mA
		T _A =125°C		15	30	
Typical junction capacitance	4V, 1MHz		C _J	110		pF

Notes: 1.Pulse test: 300 μs pulse width,1% duty cycle

2.Pulse test: pulse width≤40ms

THERMAL CHARACTERISTICS (T_A=25°C Unless otherwise noted)

Parameter	Symbol	L16	Unit
Typical thermal resistance ³⁾	R _{θJA}	206.0	°C/W
	R _{θJL}	118.0	

3.PCB Mounted with The Suggested PAD Size

AVAILABLE PACK INFORMATION

Product code	Pack	Reel Size (mm)	Quantity (pcs/reel)	Box Size L×W×H (mm)	Quantity (reel/box)	Carton Size L×W×H (mm)	Quantity (box/carton)
L16-SOD-123FL	T/R	Φ330	7500	330×35×333	2	364×364×360	8

RATINGS AND CHARACTERISTIC OF L16

FIG.1-FORWARD CURRENT DERATING CURVE

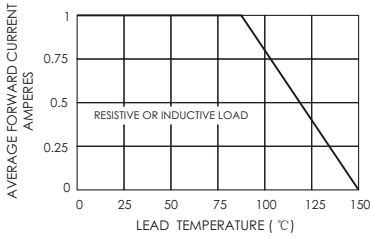

FIG.2-MAXIMUM NON-REPETITIVE PEAK FORWARD SURGE CURRENT

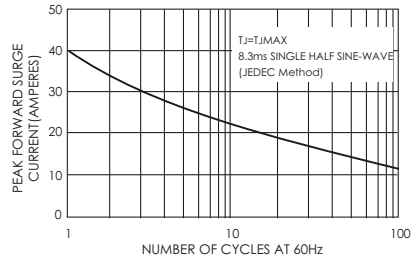

FIG.3-TYPICAL INSTANTANEOUS FORWARD CHARACTERISTICS

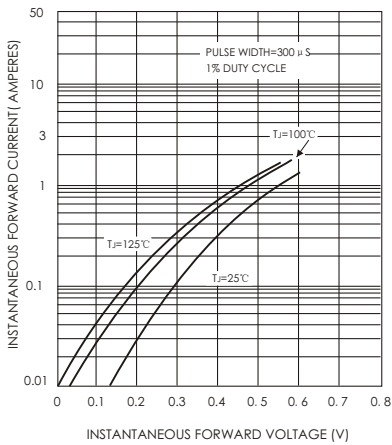

FIG.4-TYPICAL REVERSE CHARACTERISTICS

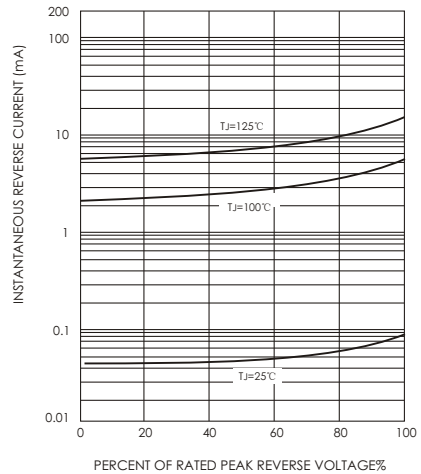

FIG.5-TYPICAL JUNCTION CAPACITANCE

