

Internet DVD (iDVD) Chip Solution

Features

- Powerful Dual 32-bit RISCs >160MIPS
- Software based on popular RTOS, C/C++
- MPEG video decoder supports DVD, VCD, VCD 3.0, SVCD standards
- Video input with picture-in-picture & zoom
- 8-bit multi-region OSD w/vertical flicker filter
- Universal subpicture unit for DVD and SVCD
- PAL<->NTSC Scaling ~ Transcoding
- Supports SDRAM and FLASH memories
- Powerful 32-bit Audio DSP >80 MIPS
- Decodes: 5.1 channel AC-3, MPEG Stereo
- Plays MP-3 CDs (a MP-3 CD =12 albums)
- Karaoke echo mix and pitch shift
- Optional 3-D Virtual, bass & treble control
- 8-channel dual-zone PCM output
- IEC-60958/61937 Out: AC-3, DTS, MPEG
- Multi-Mode Serial Audio I/O: I2S & AC-Link
- AV Bus or ATAPI interface or DVD/CD/HD
- GPIO support for all common sub-circuits

Description

Overall the CS98000 Crystal DVD Processor is targeted as a market specific consumer entertainment processor empowering new product classes with the inclusion of a DVD player as a fundamental feature. This integrated circuit when used with all the other Crystal mixed signal data converters, DSPs and high quality factory firmware enables the conception and rapid design of market leading internet age products like:

- DVD A/V Mini-System
- Home Media Controller
- Combination DVD Player
- Car/SUV Entertainment Unit

Future Firmware Enhancements:

- Web I/O via AC-Link Input & Built-in Soft Modem
- DVD Audio Navigation
- MLP Decoder, DTS Decoder, AAC Decoder
- MP-3 Encoder, Ripping Controller

ORDERING INFORMATION

CS98000-CQ	0° to 70° C	208-pin
CS98010-CQ	0° to 70° C	128-pin

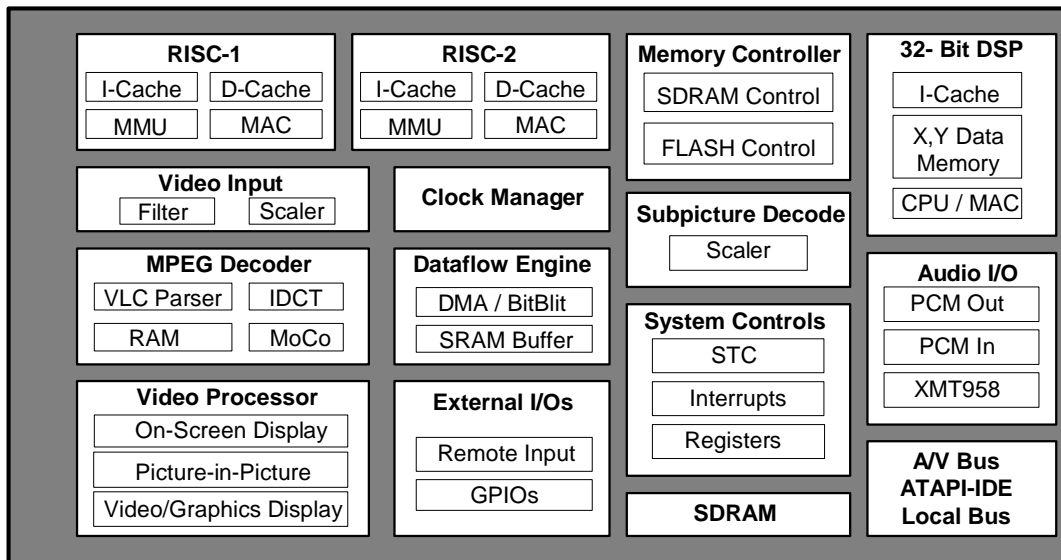

Preliminary Product Information

This document contains information for a new product. Cirrus Logic reserves the right to modify this product without notice.

TABLE OF CONTENTS

1. CHARACTERISTICS AND SPECIFICATIONS	4
1.1 AC Electrical Specifications	4
1.1.1 ATAPI Interface	4
ATAPI TRANSACTION.....	4
1.1.2 SDRAM Interface	5
1.1.3 Video Interface	7
CS98000 WITH VIDEO ENCODER.....	7
1.2 DC Electrical Specification	8
ABSOLUTE MAXIMUM RATING.....	8
ELECTRICAL CHARACTERISTICS.....	8
2. TYPICAL APPLICATION	9
3. FUNCTIONAL DESCRIPTION	10
3.1 Block Diagram	10
3.2 CS98000 Device Details	10
3.2.1 RISC-32	10
3.2.2 DSP-32	10
3.2.3 System Controls	10
3.2.4 Memory Controller	11
3.2.5 Data Flow Engine	11
3.2.6 MPEG Video Decoder	11
3.2.7 System Synchronization	11
3.2.8 Audio Interface	11
3.2.9 Video Input	11
3.2.10 External Interface	11
3.2.11 Video Processor	11
3.2.12 Sub-picture Processor	12
3.2.13 System Functions	12
3.3 RISC Processor	12
3.4 DSP Processor	12
3.5 Memory Control	12
3.6 Dataflow Control (DMA)	13
3.7 System Control Functions	13
3.8 DVD/ATAPI Interface	13
3.9 MPEG Video Decoding	13
3.10 Audio Processing	14
3.11 Soft Modem	14
3.12 Video	14

Contacting Cirrus Logic Support

For a complete listing of Direct Sales, Distributor, and Sales Representative contacts, visit the Cirrus Logic web site at:
<http://www.cirrus.com/corporate/contacts/>

Preliminary product information describes products which are in production, but for which full characterization data is not yet available. Advance product information describes products which are in development and subject to development changes. Cirrus Logic, Inc. has made best efforts to ensure that the information contained in this document is accurate and reliable. However, the information is subject to change without notice and is provided "AS IS" without warranty of any kind (express or implied). No responsibility is assumed by Cirrus Logic, Inc. for the use of this information, nor for infringements of patents or other rights of third parties. This document is the property of Cirrus Logic, Inc. and implies no license under patents, copyrights, trademarks, or trade secrets. No part of this publication may be copied, reproduced, stored in a retrieval system, or transmitted, in any form or by any means (electronic, mechanical, photographic, or otherwise) without the prior written consent of Cirrus Logic, Inc. Items from any Cirrus Logic website or disk may be printed for use by the user. However, no part of the printout or electronic files may be copied, reproduced, stored in a retrieval system, or transmitted, in any form or by any means (electronic, mechanical, photographic, or otherwise) without the prior written consent of Cirrus Logic, Inc. Furthermore, no part of this publication may be used as a basis for manufacture or sale of any items without the prior written consent of Cirrus Logic, Inc. The names of products of Cirrus Logic, Inc. or other vendors and suppliers appearing in this document may be trademarks or service marks of their respective owners which may be registered in some jurisdictions. A list of Cirrus Logic, Inc. trademarks and service marks can be found at <http://www.cirrus.com>.

4. MEMORY MAP	15
4.1 Processor Memory Map	15
4.2 Host Port Memory Map	15
4.3 Internal IO Space Map	15
5. REGISTER DESCRIPTION	16
5.1 CS98000 Register Space	16
6. PIN DESCRIPTION	25
6.1 Pin Assignments	26
6.2 Miscellaneous Interface Pins	31
6.3 SDRAM Interface	31
6.4 ROM/NVRAM Interface	31
6.5 Video Output Interface	33
6.6 Video Input Interface	33
6.7 Audio Output/Input Interface	34
6.8 AC97/CODEC Interface	34
6.9 Host Master/ATAPI Interface	35
6.10 DVD I/O Channel Interface	35
6.11 General Purpose Input/Output (GPIO)	35
6.12 Power and Ground	35
7. PACKAGE SPECIFICATIONS	38

LIST OF TABLES

atapi transaction	4
CS98000 with video Encoder	7
Absolute maximum rating	8
Electrical Characteristics	8
Table 1. Host Port Memory Map	15
Table 2. Internal IO space map	15
Table 3. CS98000 Register Map and Blocks	16
Table 4. CS98000 Registers	16
Table 5. Pin Type legend	25
Table 6. Pin assignments	26
Table 7. Miscellaneous Interface Pins	31
Table 8. SDRAM Interface	32
Table 9. ROM/NVRAM Interface	32
Table 10. Video Output Interface	33
Table 11. Video Input Interface	33
Table 12. Audio Output Interface	34
Table 13. AC97/CODEC Interface	34
Table 14. Host Master Interface	35
Table 15. DVD I/O Channel Interface	36
Table 16. General Purpose I/O Interface	36
Table 17. Power and Ground	37

LIST OF FIGURES

ATAPI Transactions - Read and Write	4
SDRAM Refresh Transaction	5
SDRAM Burst Write Transaction	5
SDRAM Burst Read Transaction	5
SDRAM Timing	6
CS98000 Interface with Video Encoder	7
CS98000 Typical Application	9
CS98000 Block Diagram	10

1. CHARACTERISTICS AND SPECIFICATIONS

1.1 AC Electrical Specifications

1.1.1 ATAPI Interface

CS98000 can interface with ATAPI-type slave loader gluelessly. Figure 1 illustrates a read ATAPI transaction and a write ATAPI transaction. PIO mode 4 is implemented for sufficient data transfer rate between ATAPI device and CS98000.

ATAPI TRANSACTION

Symbol	Description	Min	Typ	Max	Unit
Tasu	Address valid to H_RD	25	30	-	ns
Tdsu	Read data setup time	20	30	-	ns
Tc	Transaction cycle time	70	75	-	ns
Tw	Read or write pulse width	70	75	-	ns
Trdh	Read data hold time	5	15	-	ns
Twdh	Write data hold time	10	15	-	ns
Ta	H_RDY width	-	-	1250	ns
Trd	Read data valid to H_RDY valid	35	45	-	ns
Tr	H_RDY drive high to release time	5		-	ns

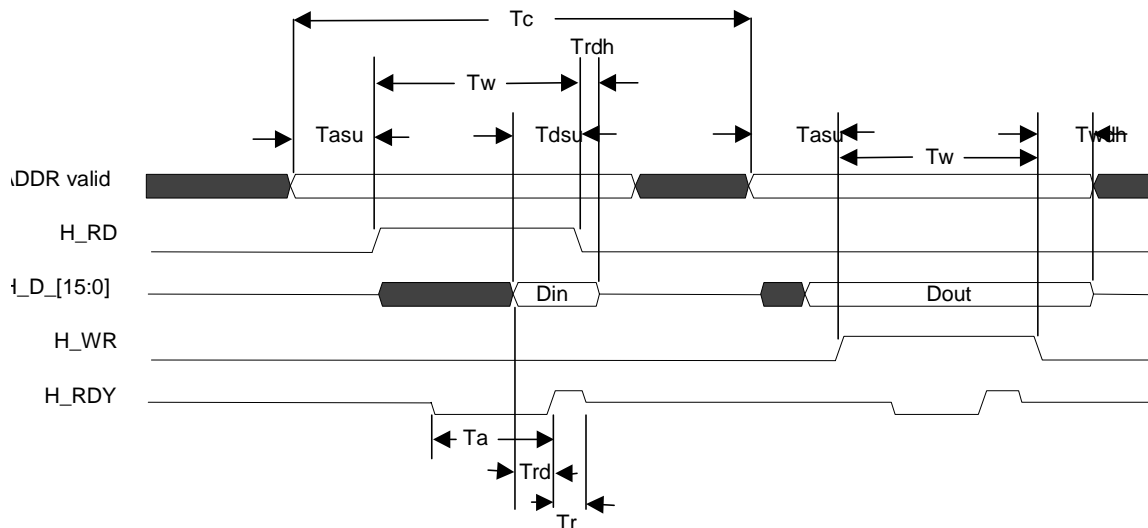

Figure 1. ATAPI Transactions - Read and Write

1.1.2 SDRAM Interface

CS98000 interfaces with either SDRAM or SGRAM for high data bandwidth transfer. Figure 2 shows the refresh cycle performed by CS98000. Figure 3 shows a burst read (length = 8) transaction, while Figure 4 shows a burst write (length = 8) transaction. Figure 5 and the following table show detailed timing. In both Figure 3 and 4, CAS latency is programmed to 3.

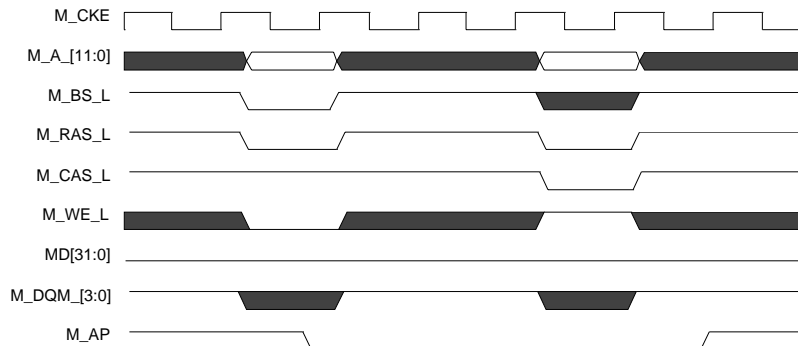

Figure 2. SDRAM Refresh Transaction

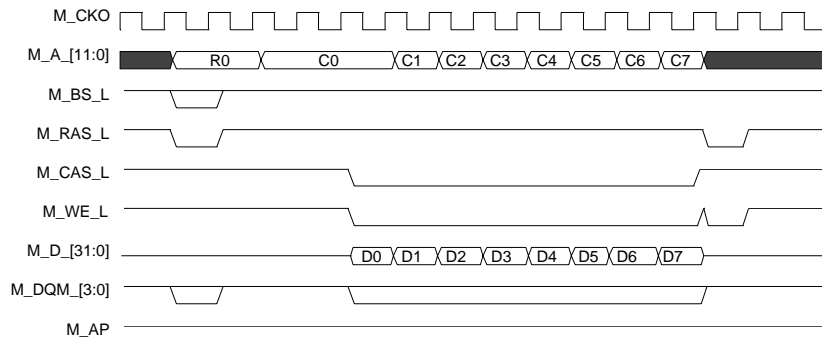

Figure 3. SDRAM Burst Write Transaction

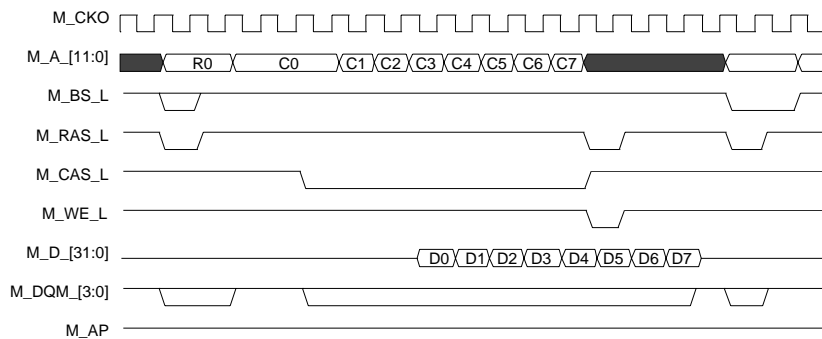
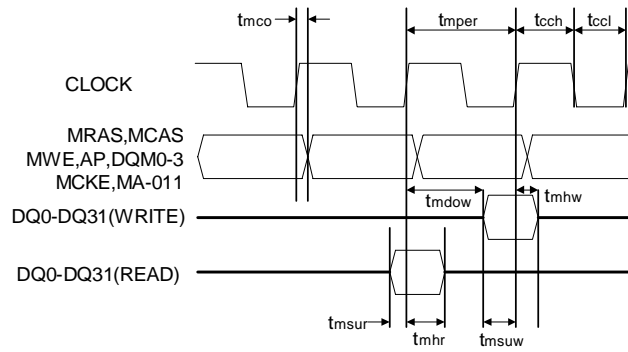

Figure 4. SDRAM Burst Read Transaction

Figure 5. SDRAM Timing

Symbol	Description	Min	Typ	Max	Unit
t_{msur}	Input to Clock Setup	3			ns
t_{mhr}	Input to Clock Hold	0			ns
t_{mco}	Clock to Out			9	ns
t_{cch}	Clk High Time	4.5			ns
t_{ccl}	Clk Low Time	4.5			ns
t_{mper}	Clk Period	10	12.2		ns
t_{mhw}	Output Hold Time	3			ns
t_{mdow}	Clk to Data Bus Valid			5	ns
t_{msuw}	Data Valid to Clk	3			ns

1.1.3 Video Interface

Figure 6 illustrates the CS98000 interfaces with standard video encoder.

CS98000 WITH VIDEO ENCODER

Symbol	Description	Min	Typ	Max	Unit
Tdsu	Video data setup time	5			ns
Tdh	Video data hold time	5			ns
Tsysu	HSYNC or VSYNC to Clock setup time	5			ns
Tsyh	Clock to HSYNC or VSYNC hold time	5			ns
Tckl	Video clock low time	14.8		22.2	ns
Tckh	Video clock high time	14.8		22.2	ns

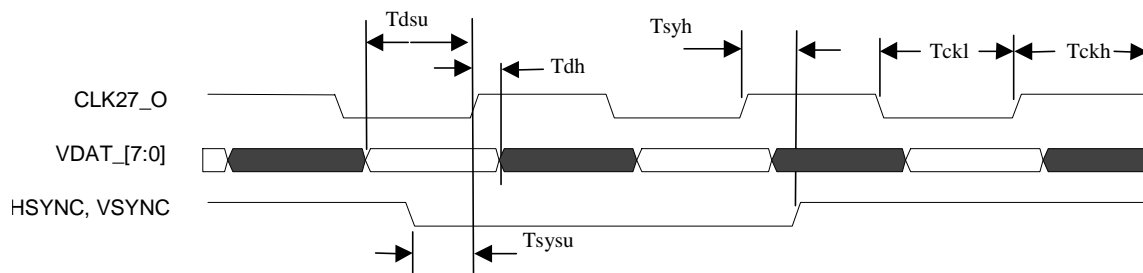

Figure 6. CS98000 Interface with Video Encoder

1.2 DC Electrical Specification

ABSOLUTE MAXIMUM RATING

Symbol	Description	Min	Max	Unit
VDD _{IO}	Power Supply Voltage on I/O ring	-0,5	4.6	Volts
VDD _{CORE}	Power Supply Voltage on core logic and PLL	-0.5	3.6	Volts
V _I	Digital Input Applied Voltage (power applied)	-0.5	5.5	Volts
I _I	Digital Input Forced Current	-10	10	mA
I _O	Digital Output Forced Current	-50	50	mA
T _{SOL}	Lead Soldering Temperature	-	260	°C
T _{VSOL}	Vapor Phase Soldering Temperature	-	220	°C
T _{STOR}	Storage Temperature (no power applied)	-40	125	°C
T _{AMB}	Ambient Temperature (power applied)	0	70	°C
P _{IO}	Power consumption on I/O ring (C _L = 35 pF)	-	57	mA
P _{CORE}	Power consumption on the core logic	-	620	mA
P _{PLL}	Power consumption on the PLL logic	-	15	mA

ELECTRICAL CHARACTERISTICS (TA = 0 to 70 °C)

Parameter	Symbol	Conditions	Min	Typ	Max	Units
Supply Voltage, IO	V _{DD}		3.0	3.3	3.6	Volts
Supply Voltage, core and PLL	V _{DD}		2.25	2.5	2.75	Volts
Supply Current, IO	I _{DD}	Normal Operating	-	45	-	mA
Supply Current, core and PLL	I _{DD}	Normal Operating	-	550	-	mA
Input Voltage, High	V _{IH}		2.0	-	5.0	Volts
Input Voltage, Low	V _{IL}		-	-	0.8	Volts
Input Current	I _{IN}	V _{IN} = V _{DD} or V _{SS}	-1	-	+1	µA
Input Pull up/down resistor	R _I		-	75	-	KΩ
Output Voltage, High	V _{OH}	@ buffer rating	2.4	-	-	Volts
Output Voltage, Low	V _{OL}	@ buffer rating	-	-	0.4	Volts
Tristate Leakage	I _{OZ}	V _{OUT} = V _{SS} or V _{DD}	-10	-	+10	µA
Input Capacitance	C _{IN}		-	3	-	pF
Output Capacitance	C _{OUT}		-	3-6	-	pF
Bidirect Capacitance	C _{BID}		-	3-6	-	pF

2. TYPICAL APPLICATION

The Figure 7 shows a typical example of a complete internet-DVD solution using the CS98000.

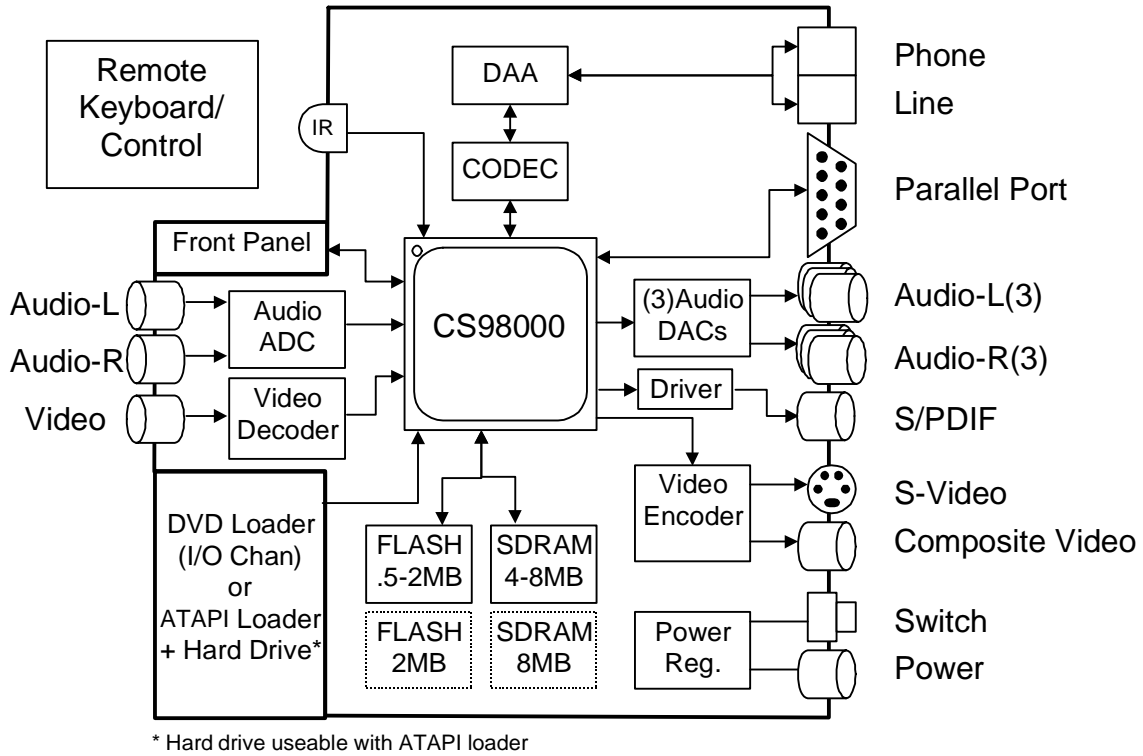

Figure 7. CS98000 Typical Application

3. FUNCTIONAL DESCRIPTION

3.1 Block Diagram

The CS98000 block is shown in Figure 8.

3.2 CS98000 Device Details

3.2.1 RISC-32

- Powerful 32-bit RISC processor
- Virtual memory support
- Optimizing C compiler and source level debugger
- Big or little endian data formats support
- MAC multiply/accumulate in 2 cycles with C support.
- 4 Kbyte instruction cache, 2 Kbyte data cache.
- Single cycle instructions, runs at 81 Mhz.

3.2.2 DSP-32

- Powerful 24/32 bit DSP processor
- 24 bit fixed point logic, with 54 bit accumulator.
- Single-cycle throughput, 2 cycle latency multiply accumulate, 32 bit simple integer logic. 8 Kbyte instruction cache, 8 Kbyte program visible local memory
- Single cycle instructions, runs at 81 Mhz.

3.2.3 System Controls

- Include several hardware lockable semaphore registers
- General-purpose register for inter-processor communication
- 32-bit timers for I/O and other uses, with programmable interval rates

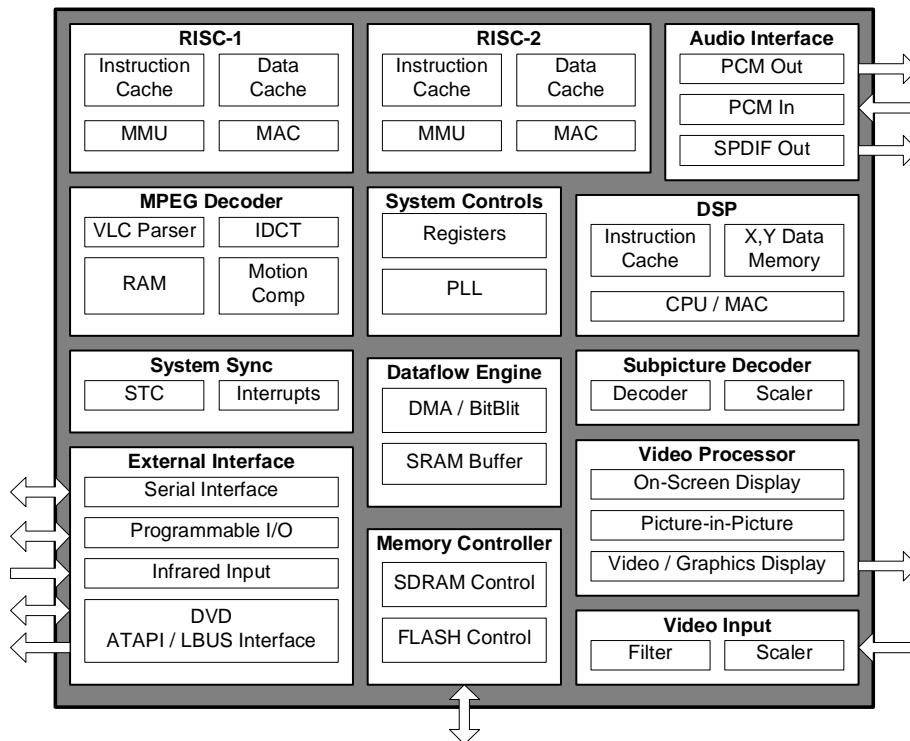

Figure 8. CS98000 Block Diagram

- Both hardware and software interrupts on data or debug
- Performance monitors which measures DRAM bandwidth, usage, and RSK performance
- Built in PLLs generate all required clocks from 27 Mhz input clock.

3.2.4 Memory Controller

- Supports SDRAM, and SGRAM, from 2 MB to 32 MB.
- Supports multiple banks of FLASH and ROM up to 32 MB.
- 32-bit data bus for DRAM, 8 or 16 bit data bus for ROM.

3.2.5 Data Flow Engine

- 2432 bytes of internal memory.
- DMA to/from main RAM into local SRAM.
- Supports endian conversion and byte, short, long data formats on DMA.
- Supports block transfers for graphics bit blits.

3.2.6 MPEG Video Decoder

- Supports VCD, VCD 3.0, SVCD, DVD video standards.
- Supports trick features, including smooth 2x play and reverse play.
- Special anti-tearing logic controls picture decode and presentation.
- Advanced error concealment hardware.

3.2.7 System Synchronization

- System time clock (STC) for audio/video synchronization
- Flexible interrupt structure for controlling decode and presentation times
- Hardware scheduling of subpicture and highlight events

3.2.8 Audio Interface

- Supports PCM, I²S and IEC-958 outputs at up to 96 KHz output rate.
- 8 output channels, 2 input channels.

3.2.9 Video Input

- NTSC/PAL video decoder input interface.
- Built in variable down scaling, handles CCIR 601 to QCIF input formats.
- Video input image can be displayed in small window, or as main picture

3.2.10 External Interface

- Serial I2C master and slave port.
- 29 independent fully programmable bi-directional I/O pins.
- 8 edge or level detection interrupt pins.
- Hardware assisted support for infrared remote devices, such as remote control, infrared keyboard, mouse, printer, and more.
- Programmable parallel host master and slave interface supports many formats including ATAPI, ISA, and more.
- IO channel interface supports standard DVD loader protocols
- Serial interface supports AC-97 and other standard MODEM CODEC protocols

3.2.11 Video Processor

- Supports 24 bit 4:2:0 and 4:2:2 video modes, and 16 bit true color graphics modes. On screen display module supports 2-bit, 4-bit, or 8-bit pixel modes. It supports 3 separate regions and 16 transparency overlay levels
- Picture-in-picture module includes horizontal and vertical downscaling. Supports programmable output sizes, positions, and borders
- Overlay mixer with RGB to YUV conversion and output formatting

- Supports 4:2:0, 4:2:2, YUV655, RGB565 and RGB555 frame buffer inputs.
- High quality scaling using a vertical and a horizontal 16 taps polyphase programmable filter, to support any size image up to 768x576.
- Programmable sharpening and de-blocking filters.
- 5 taps programmable adaptive anti-flicker filtering for Graphics source.
- Master or Slave video sync configuration.
- Outputs 4:2:2 video in CCIR-601 or CCIR-656 format.
- Multiple video plains overlay (main video/video input/picture_in_picture picture/on_screen display/cursor).
- Gamma Correction.

3.2.12 Sub-picture Processor

- Run-length decode DVD sub-pictures and SVCD OGT formats
- Hardware vertical scaling supports NTSC-PAL format conversion
- 16 level alpha blending
- Provides hardware cursor mode for non-DVD applications

3.2.13 System Functions

- 128 and 208-pin PQFP packages.
- All I/O pins are 3 V with 5 V tolerance.
- Advanced 0.25 micron CMOS technology.
- Internal processors run at 81 MHz
- Supports Low power modes and clock shutoff.

3.3 RISC Processor

The CS98000 includes two powerful, proprietary 32-bit RISC processors, called RISC, with optimizing C compiler support and source level debugger. The RISC has an instruction set that is a superset of

MIPS R3000. In addition to the standard MIPS R3000 instruction code, the RISC processor also has a MAC engine, which performs multiply/accumulate in 2 cycles in a pipelined fashion with C support, effectively achieving single cycle throughout. There are other instructions that are designed to help with performing MPEG1/2 decoding. The CS98000 fully supports many Real Time Operating Systems (RTOS) such as WindRiver[®] OS and ATI. The RISC processor co-ordinates on-chip multi-threaded tasks, as well as system activities such as remote control and front panel control.

3.4 DSP Processor

The CS98000 contains a proprietary digital signal processor (DSP) called DSP, which is optimized for audio and sound applications. The DSP performs 32 bit simple integer operations, and has a 24 bit fixed point logic unit, with a 54 bit accumulator. There are 32 general-purpose registers, and eight independent address generation registers, featuring: post-increment ALU, linear and circular buffer operations, bit reverse ALU operations, and dual operand read from memory. The multiply-accumulator has single-cycle throughput, with two cycle latency. The DSP is optimized for bit packing and unpacking operations. The interface to main memory is designed for handling flexible block sizes and skip counts.

3.5 Memory Control

The DRAM Interface performs the SDRAM control and arbitration functions for all the other modules in the CS98000. The DRAM interface services and arbitrates a number of clients and stores their code and/or data within the local memory. This arbitration and scheduling guarantees the allocation of sufficient bandwidth to the various clients. The DRAM Interface supports up to 32 MB. For a typical DVD player application, CS98000 requires 4 MB memory space.

Sharing the same interface, CS98000 also supports flash ROM, OTP, or mask ROM interface. Code is stored in ROM. After system is booted, the code is shadowed inside DRAM for execution. The flash ROM interface is provided so that the code can be upgraded in the field once the communications channel is established (modem port, CD-R, serial port). Utility software will be provided to debug and upgrade code for the system manufacturer.

3.6 Dataflow Control (DMA)

The DMA controller moves data between the external memory and an internal memory. The external memory address can be specified using a register, or in FIFO mode, using start and end address registers. Separate start/end address registers are used for DMA read and write operations. The DMA interface also has a block transfer function, which allows for the transfer of one block of data from one external memory location to another external memory location. In effect, combining a DMA read and write into one operation. In addition, the DMA write operation allows for byte, short, word, and other types of masking.

3.7 System Control Functions

The system control functions are used to coordinate the activities of the multiple processors, and to provide the supporting system operations. Four 32-bit communication registers are available inter-processor communication, and eight semaphore registers are used for resource locking. Timers are available for general-purpose functions, as well as more specialized functions such as watchdog timers and performance monitoring. The large number of general purpose I/Os offers flexibility in system configurations. An I2C master allows for control of other I2C devices, such as a video encoder. An I2C slave port shares the same pins, and can be used for debug functions. Interrupts can be generated on specific or generic events. Infrared inputs can be filtered of glitches or stored unfiltered into memory. Control of all the internal clocks is also possi-

ble. Internal PLLs are used to generate the internal system and memory clocks, and audio clocks of any widely used frequency.

3.8 DVD/ATAPI Interface

The CS98000 has a programmable interface port which can be configured to connect to industry standard CD/DVD loaders without external glue logic. The CD/DVD interface fully supports popular CD/DVD loaders such as Sanyo, Sony and AVS. The interface consists of DVD control and data ports, and an optional CD control/data port. The CS98000 hardware manages the DVD interface and moving data to an arbitrary size input FIFO in DRAM.

The same interface pins can be optionally configured as a generic 16-bit host master port. In this mode, the CS98000 can control up to four devices (using 4 chip select outputs), each of which may use different protocol and timing. The interface can be set up in ATAPI mode, to connect directly to any ATAPI DVD loader (using two chip selects). Simultaneously, the other two chip selects can be configured to connect to other devices, such as a super I/O chip or hard disk.

A third option is to configure the interface for micro-less DVD loader operation, which may also be configured to connect without external glue logic.

3.9 MPEG Video Decoding

Compressed MPEG data is read from the DVD disk into an input FIFO in DRAM. The data flow (DMA) controller moves Video packets from the input FIFO into the MPEG decoder's input FIFO (also in DRAM). The DMA controller can also perform advanced functions such as start code search, relieving the RISC processors. The System Sync function is used to control the timing of MPEG picture decoding. The MPEG Video decoder processes I, B and P frames, and writes to video frame buffers in DRAM for output to the display. Special

anti-tearing logic ensures that currently displayed frame buffers are not overwritten.

3.10 Audio Processing

Compressed Audio data is read from the DVD disk into an input FIFO in DRAM. The data is decompressed, then written to a PCM output FIFO, also in DRAM. Presentation time stamps (PTS) are extracted from the stream to update the STC, in order to maintain audio/video synchronization.

The DMA and decompression stages of audio processing can be done with a combination of the DMA unit, DSP and RISC processors. The DSP is optimized for audio processing, so most common formats can be handled by the DSP alone, including AC-3, MPEG2 audio, and MP3. The DSP has enough reserve bandwidth to handle the Karaoke echo-mix and pitch shift, and AC-3 down-mix functions.

The audio output data is written into a DRAM FIFO in 16, 18 or 20 bit PCM format. A flexible audio output stage can simultaneously output 8 channels of PCM data to audio DAC's, or 6 channels of audio data plus an IEC-958 encoded output, at up to 96 KHz. The audio interface also includes a flexible PCM input interface, which can input a wide range of protocols from an audio ADC or IEC-958 receiver.

3.11 Soft Modem

The soft modem processing is handled by one of the RISC processors, which is typically dedicated for that function. Data rates up to 56 K (V.90 protocol) are supported. The CS98000 interfaces to a simple external CODEC/DAA circuit using a flexible serial interface. The serial interface is a fully programmable, bi-directional interface and can be used either as a PCM interface or as an AC97 interface. In PCM mode, the sample size could be adjusted to 20, 18 or 16 bits to match common DAC and ADC formats, or any other specific size. In

AC97 mode, any slot can be used to interface either a modem CODEC or an audio CODEC.

3.12 Video

The Digital Video Interface provides flexible and powerful means of outputting digital video data to external devices in CCIR601/3 and CCIR656 YUV formats. The interface directly supports NTSC/PAL video encoder, in both master and slave sync configurations. The internal frame buffer format could be 4:2:0, 4:2:2, YUV655, RGB565 and RGB555. Cirrus Logic provides some easy to use utilities in order to get the best advantage of the powerful video filtering capabilities of the CS98000. The CS98000 also features an NTSC/PAL video decoder input interface. The interface accepts CCIR, CIF, and QCIF formats, out of many TV decoders on the market. The video processor also allows multiple video plans overlay (main video / video input / picture_in_picture / on_screen display / cursor). CS98000 has been proven to work with many TV encoders on the market with brands, such as, Crystal, Brooktree, ADI, and AVS.

The Video Input Scaler (VIS) module inputs 8-bit digital video data from a camera or PAL/NTSC decoder, optionally down-scales to SIF or QSIF, and stores the data in one to three DRAM frame buffers. The scaled image, with a border, can be overlaid anywhere on the screen into a 1/2 or 1/4-screen sized window by the Picture in Picture (PIP) module.

An alternate method of using the Video Input function is to input a full sized picture, and present it on the screen full size (bypass mode). In this mode, the PIP module can place full motion DVD images in the small window. An internal glitch-free mux can switch the video processor clock source from the internal clock to the Video Input clock, allowing the PIP mode to switch back and forth on the fly, with no dropout.

4. MEMORY MAP

4.1 Processor Memory Map

The CS98000 externally supports up to 32 Mbytes DRAM and 16 Mbytes ROM/NVRAM. Table lists the memory map as viewed by the RISC processors, and identifies whether each segment is mapped or cacheable.

Processor byte address	Description	Cacheable
0000_0000 – 07FF_FFFF	DRAM (mapped)	Y
8000_0000 - 81FF_FFFF	DRAM (32 Mbytes)	Y
9400_0000 – 9CFF_FFFF	16 bit NVRAM write (16 Mbytes)	N
9C00_0000 – 9CFF_FFFF	16 bit NVRAM/ROM (16 Mbytes)	Y
9D00_0000 – 9DFF_FFFF	8 bit NVRAM/ROM (16 Mbytes)	Y
A000_0000 – A1FF_FFFF	DRAM (32 Mbytes)	N
B000_0000 – B003_FFFF	Internal I/O (256 Kbytes)	N
B400_0000 – BCFF_FFFF	16 bit NVRAM write (16 Mbytes)	N
BC00_0000 – BCFF_FFFF	16 bit NVRAM/ROM (16 Mbytes)	N
BD00_0000 – BDFF_FFFF	8 bit NVRAM/ROM (16 Mbytes)	N
C000_0000 – FFFF_FFFF	DRAM (mapped)	Y

Memory Map - RISC Processor

4.2 Host Port Memory Map

Table 1 lists the memory map as viewed by host slave port.

4.3 Internal IO Space Map

Table 2 shows how the Internal IO space is mapped between general registers, internal SRAM ports, and the RISC processors' debug port.

Host byte address	Description
0000 0000 – 003F FFFF	Internal I/O Space
1000 0000 – 13FF FFFF	DRAM space (16 Mbytes)
1400 0000 – 17FF FFFF	NVRAM space (16 Mbytes)

Table 1. Host Port Memory Map

Byte address offset	Description
0_0000 – 0_2FFF	General registers
0_3000 – 1_FFFF	General Internal SRAM
2_0000 – 2_FFFF	RISC_0 Internal SRAM/Registers
3_0000 – 3_FFFF	RISC_1 Internal SRAM/Registers

Table 2. Internal IO space map

5. REGISTER DESCRIPTION

5.1 CS98000 Register Space

Table 3 lists the register groups, and how they are split among the main CS98000 functional blocks.

Table 4 lists all the registers for the CS98000 and their addresses, and indicates whether the registers are read/write (R/W), read only (RO) or write only (WO).

CS98000 Register	Block
000xx, 010xx	General
001xx	Host
002xx	DRC
003xx	DMA
004xx	DVD Interface
005xx	Serial Interface
006xx	DSP
007xx	Sync Control
008xx	MPEG Video Decoder
009xx	Video Input Scaler
00Axx	Picture-in-picture
00Bxx	Video Processor
00Cxx	Subpicture Display
00Dxx	On-screen Display
00Exx	PCM In/Out
02xxxx	RISC_0
03xxxx	RISC_1

Table 3. CS98000 Register Map and Blocks

Address	Type	Function	Register Name
000	R/W	General	Command
010	R/W	General	InterProc_Comm_Register_0
014	R/W	General	InterProc_Comm_Register_1
018	R/W	General	InterProc_Comm_Register_2
10C	R/W	General	InterProc_Comm_Register_3
020	R/W	General	Semaphore_Register_0
024	R/W	General	Semaphore_Register_1
028	R/W	General	Semaphore_Register_2
02C	R/W	General	Semaphore_Register_3
030	R/W	General	Semaphore_Register_4
034	R/W	General	Semaphore_Register_5
038	R/W	General	Semaphore_Register_6

Table 4. CS98000 Registers

03C	R/W	General	Semaphore_Register_7
040	RO	General	GenIO_Read_Data
044	R/W	General	GenIO_Write_Data
048	R/W	General	GenIO_Tri_State_Enable
04C	R/W	General	GenIO_Positive_Edge
050	R/W	General	GenIO_Negative_Edge
054	R/W	General	GenIO_Interrupt_Status
058	R/W	General	GenIO_Positive_Edge_Mask
05C	R/W	General	GenIO_Negative_Edge_Mask
060	R/W	General	GenIO_Level_Mask
064	R/W	General	GenIO_Mode Register
1040	RO	General	GenIOMIS_Read_Data
1044	R/W	General	GenIOMIS_Write_Data
1048	R/W	General	GenIOMIS_Tri_State_Enable
104C	R/W	General	GenIOMIS_Positive_Edge
1050	R/W	General	GenIOMIS_Negative_Edge
1054	R/W	General	GenIOMIS_Interrupt_Status
1058	R/W	General	GenIOMIS_Positive_Edge_Mask
105C	R/W	General	GenIOMIS_Negative_Edge_Mask
1060	R/W	General	GenIOMIS_Level_Mask
1064	R/W	General	GenIOMIS_Mode Register
1068	RO	General	GenIODVD_Read_Data
106C	R/W	General	GenIODVD_Write_Data
1070	R/W	General	GenIODVD_Tri_State_Enable
1074	RO	General	GenIOHST_Read_Data
1078	R/W	General	GenIOHST_Write_Data
107C	R/W	General	GenIOHST_Tri_State_Enable
068	R/W	General	I2C_Mstr_Read_Comand
06C	R/W	General	I2C_Mstr_Write_1Byte
070	R/W	General	I2C_Mstr_Write_2Bytes
074	R/W	General	I2C_Mstr_Control
078	RO	General	I2C_Mstr_Status
07C	RO	General	I2C_Mstr_Read_Data
080	R/W	General	RSK0_Interrupt_Mask
084	WO	General	RSK0_Interrupt_Set
088	R/W	General	RSK0_Interrupt_Status
08C	RO	General	RSK0_Interrupt_Cause
090	R/W	General	DSP_Interrupt_Mask
094	WO	General	DSP_Interrupt_Set
098	R/W	General	DSP_Interrupt_Status
09C	RO	General	DSP_Interrupt_Cause

Table 4. CS98000 Registers (Continued)

0A0	R/W	General	RSK0_Interrupt_Mask2
0A4	WO	General	RSK0_Interrupt_Set2
0A8	R/W	General	RSK0_Interrupt2_Status
0AC	RO	General	RSK0_Interrupt_Cause2
1080	R/W	General	RSK1_Interrupt_Mask
1084	WO	General	RSK1_Interrupt_Set
1088	R/W	General	RSK1_Interrupt_Status
108C	RO	General	RSK1_Interrupt_Cause
10A0	R/W	General	RSK1_Interrupt_Mask2
10A4	WO	General	RSK1_Interrupt_Set2
10A8	R/W	General	RSK1_Interrupt2_Status
10AC	RO	General	RSK1_Interrupt_Cause2
0B0	R/W	General	DSP_Interrupt_Mask2
0B4	WO	General	DSP_Interrupt_Set2
0B8	R/W	General	DSP_Interrupt2_Status
0BC	RO	General	DSP_Interrupt_Cause2
0C0	R/W	General	Timer_0
0C4	R/W	General	Timer_1
0C8	R/W	General	Timer_2
0CC	R/W	General	Timer_3
0D0	R/W	General	Timer_Control
0D4	RO	General	Performance_Monitor_Count
0D8	R/W	General	Timer_M_Over_N
0E0	R/W	General	IR_Control
0E4	R/W	General	IR_Dram_Start_Address
0E8	R/W	General	IR_Dram_End_Address
0EC	RO	General	IR_Dram_Write_Address
0F0	R/W	General	PLL_Control_Register1
10F0	R/W	General	Low_Power_Clock_Control
0F4	R/W	General	PLL_Control_Register2
10F4	R/W	General	PLL_Control_Register3
0F8	R/W	General	PLL_Turn_Off
0FC	R/W	General	PLL_Clock_Divider
100	R/W	Host	Device_1_Control
104	R/W	Host	Device_2_Control
108	R/W	Host	Device_3_Control
10C	R/W	Host	Device_4_Control
110	R/W	Host	Write_Data_Port
114	RO	Host	Read_Data_Port
120	R/W	Host	Host_Start_Address
124	R/W	Host	Dram Start Address

Table 4. CS98000 Registers (Continued)

128	R/W	Host	Stream_Transfer_Size
12C	R/W	Host	DRAM_Burst_Threshold
13C	R/W	Host	Host_Master_Control
200	R/W	Dram controller	DRAM_Controller_Priority0
204	R/W	Dram controller	DRAM_Controller_Priority1
208	R/W	Dram controller	DRAM_Controller_Priority2
20C	R/W	Dram controller	DRAM_Controller_Priority3
210	R/W	Dram controller	DRAM_Controller_Priority4
214	R/W	Dram controller	DRAM_Controller_Setup
218	R/W	Dram controller	DRAM_Command
21C	R/W	Dram controller	DRAM_Controller_Mb_Width
220	R/W	Dram controller	DRAM_Controller_Debug_Control
224	RO	Dram controller	DRAM_Debug_Status
300	WO	DMA	DMA_Enable
304	R/W	DMA	DMA_Control
308	RO	DMA	DMA_Status
30C	R/W	DMA	Xfer_Byte_Cnt
310	R/W	DMA	Dram_Byte_Start_Addr
314	R/W	DMA	Sram_Byte_Start_Addr
318	R/W	DMA	Fifo_Start_Rd_Addr
31C	R/W	DMA	Fifo_Start_Wr_Addr
328	R/W	DMA	Search_Control
32C	RO	DMA	Search_Status
330	R/W	DMA	Fifo_End_Rd_Addr
334	R/W	DMA	Fifo_End_Wr_Addr
338	R/W	DMA	Lines_and_Skip
33C	R/W	DMA	Byte_Mask_Pattern
400	R/W	CD/DVD	DVD1_Control
404	R/W	CD/DVD	DVD1_Fifo_Base_Address
408	R/W	CD/DVD	DVD1_Fifo_Size
40C	R/W	CD/DVD	DVD1_Sector
410	RO	CD/DVD	DVD1_Start_of_Sector
414	RO	CD/DVD	DVD1_Current_Dram_Address
418	R/W	CD/DVD	CD_Control
41C	R/W	CD/DVD	CD_Error_Status
438	RO	CD/DVD	DVD1_Status
440	R/W	SER/DCI	DCI_Control_Reg
444	RO	SER/DCI	DCI_Status
448	R/W	SER/DCI	DCI_Dram_Rd_Start_Addr
44C	R/W	SER/DCI	DCI_Dram_Wr_Start_Addr
450	R/W	SER/DCI	DCI_Nbytes_Sent

Table 4. CS98000 Registers (Continued)

454	R/W	SER/DCI	DCI_Mbytes_Switch
458	RO	SER/DCI	DCI_Diagnostic
45C	R/W	SER/DCI	DCI_Active
540	R/W	SER/DCI	Serial_Frame_Sync_Control
544	R/W	SER/DCI	Serial_Output_Input_Control
548	R/W	SER/DCI	AC97_Codec_Control
54C	R/W	SER/DCI	AC97_Codec_Command
550	R/W	SER/DCI	Serial_Output_Fifo_Start_Address
554	R/W	SER/DCI	Serial_Output_Fifo_End_Address
558	R/W	SER/DCI	Serial_Input_Fifo_Start_Address
55C	R/W	SER/DCI	Serial_Input_Fifo_End_Address
560	RO	SER/DCI	Serial_Output_Fifo_Read_Address
564	RO	SER/DCI	Serial_Input_Fifo_Write_Address
568	R/W	SER/DCI	Serial_Clock_Synthesis_Parameters
56C	RO	SER/DCI	Codec_Register_Status
570	R/W	SER/DCI	Slot5_Register_Data
574	R/W	SER/DCI	Slot10_Register_Data
578	R/W	SER/DCI	Slot11_Register_Data
57C	R/W	SER/DCI	Slot12_Register_Data
580	R/W	SER/DCI	Out_fifo_int
584	R/W	SER/DCI	In_fifo_int
588	R/W	SER/DCI	Rate_Control
600	WO	DSP	DSP_Boot_Code_Start_Address
604	WO	DSP	DSP_Run_Enable
6XX	RO	DSP	DSP_Program_CntRun_Status
700	R/W	Sync Control	Audio_Sync_Control
704	R/W	Sync Control	Video_Sync_Control
708	RO	Sync Control	Video_Sync_Status
70C	R/W	Sync Control	Wait_Line
710	R/W	Sync Control	Frame_Period
714	R/W	Sync Control	STC_Interval
718	R/W	Sync Control	System_Time_Clock
71C	R/W	Sync Control	Top_Bits
720	R/W	Sync Control	Video_PTS_FIFO_Start_Address
724	R/W	Sync Control	Video_PTS_FIFO_End_Address
728	R/W	Sync Control	Video_PTS_FIFO_Write_Address
72C	RO	Sync Control	Video_PTS_FIFO_Read_Address
730	R/W	Sync Control	Subpicture_PTS_FIFO_Start_Address
734	R/W	Sync Control	Subpicture_PTS_FIFO_End_Address
738	R/W	Sync Control	Subpicture_PTS_FIFO_Write_Address
73C	RO	Sync Control	Subpicture_PTS_FIFO_Read_Address

Table 4. CS98000 Registers (Continued)

740	R/W	Sync Control	Highlight_Start_PTS
744	R/W	Sync Control	Highlight_End_PTS
748	R/W	Sync Control	Button_End_PTS
74C	RW	Sync Control	Highlight_Control_Information_Address
750	R/W	Sync Control	Video_PTS
754	R/W	Sync Control	Audio_PTS
758	RO	Sync Control	Subpicture_PTS
75C	RO	Sync Control	Audio_Time
760	RO	Sync Control	Video_Sync_Debug
764	R/W	Sync Control	SP_DRC_VPTS_Debug
768	R/W	Sync Control	Frame_Count_Interrupt
76C	R/W	Sync Control	Video_DTS
770	RO	Sync Control	Sync_Interrupt_Status
774	R/W	Sync Control	Sync_Interrupt_Control
778	WO	Sync Control	Sync_Interrupt_Set
77C	WO	Sync Control	Sync_Interrupt_Clear
800	R/W	MPEG Vid. Decoder	MPEG_Video_Control
804	R/W	MPEG Vid. Decoder	MPEG_Video_Setup
808	R/W	MPEG Vid. Decoder	MPEG_Video_FIFO_Start_Address
80C	R/W	MPEG Vid. Decoder	MPEG_Video_FIFO_End_Address
810	RO	MPEG Vid. Decoder	MPEG_Video_FIFO_Current_Address
814	RO	MPEG Vid. Decoder	MPEG_Video_Horiz_Pan_Vector
818	WO	MPEG Vid. Decoder	MPEG_Video_FIFO_Add_Bytes
81C	RO	MPEG Vid. Decoder	MPEG_Video_FIFO_Curr_Bytes
820	R/W	MPEG Vid. Decoder	MPEG_Video_FIFO_Interrupt_Bytes
824	RO	MPEG Vid. Decoder	MPEG_Video_FIFO_Total_Bytes
828	RO	MPEG Vid. Decoder	MPEG_Video_Status
82C	R/W	MPEG Vid. Decoder	Macroblock_Width_Height
830	RO	MPEG Vid. Decoder	MPEG_Video_Debug
834	R/W	MPEG Vid. Decoder	MPEG_U_Offset
83C	R/W	MPEG Vid Decoder	MPEG_I_Base_Register
840	R/W	MPEG Vid Decoder	MPEG_P_Base_Register
844	R/W	MPEG Vid Decoder	MPEG_Dest_Control
848	RO	MPEG Vid Decoder	MPEG_Software_Flags
84C	R/W	MPEG Vid Decoder	MPEG_V_Offset
854	R/W	MPEG Vid Decoder	MPEG_AntiTearWindow
858	R/W	MPEG Vid Decoder	MPEG_Error_Pos
900	R/W	VIS	VIS_Control
904	R/W	VIS	VIS_StartX
908	R/W	VIS	VIS_EndX
90C	R/W	VIS	VIS_StartY

Table 4. CS98000 Registers (Continued)

910	R/W	VIS	VIS_EndY
914	R/W	VIS	VIS_Frame_Base
918	R/W	VIS	VIS_U_Offset
91C	R/W	VIS	VIS_V_Offset
920	R/W	VIS	VIS_Frame_Size
A00	R/W	PIP	PIP_Control
A04	R/W	PIP	PIP_VidBrdStartX
A08	R/W	PIP	PIP_VidBrdEndX
A0C	R/W	PIP	PIP_VidBrdStartY
A10	R/W	PIP	PIP_VidBrdEndY
A14	R/W	PIP	PIP_BorderClr
A18	R/W	PIP	PIP_Vscale
A1C	R/W	PIP	PIP_Line_Offnum_Bot
A20	R/W	PIP	PIP_FrBaseY
A24	R/W	PIP	PIP_FrBaseU
A28	R/W	PIP	PIP_FrBaseV
A2C	R/W	PIP	PIP_Line_Width
A30	R/W	PIP	PIP_Line_Offnum_Top
A34	R/W	PIP	PIP_Frame_Size
B00	R/W	Video Processor	Video_Processor_Control
B04	R/W	Video Processor	Video_DRAM_Line_Length
B08	R/W	Video Processor	Display_ActiveX
B0C	R/W	Video Processor	Display_ActiveY
B10	R/W	Video Processor	Blank_Color
B14	R/W	Video Processor	Internal_Hsync_Count
B18	R/W	Video Processor	Internal_Vsync_Count
B1C	R/W	Video Processor	Horizontal_Y_Offset
B20	R/W	Video Processor	Horizontal_UV_Offset
B24	R/W	Video Processor	Vertical_Offset
B28	R/W	Video Processor	Video_Line_Size
B2C	R/W	Video Processor	Frame_Buffer_Base
B30	R/W	Video Processor	Video_Line_Mode_Buffer
B34	R/W	Video Processor	Horizontal_Vertical_Filter
B38	R/W	Video Processor	Source_X_Offset
B3C	R/W	Video Processor	Horizontal_Video_Scaling
B40	R/W	Video Processor	Frame_V_Buffer_Compressed_Offset
B44	WO	Video Processor	Mb_Width
B48	WO	Video Processor	Anti-Flicker
B4C	WO	Video Processor	Anti-Flicker
B50	WO	Video Processor	Anti-Flicker
B54	WO	Video Processor	Anti-Flicker

Table 4. CS98000 Registers (Continued)

B58	WO	Video Processor	Anti-Flicker
B5c	WO	Video Processor	Gamma Control
B60	WO	Video Processor	Gamma Control
B64	WO	Video Processor	Gamma Control
B68	WO	Video Processor	Gamma Control
B6C	WO	Video Processor	Gamma Control
B70	WO	Video Processor	Gamma Control
B74	WO	Video Processor	Gamma Control
B78	WO	Video Processor	Gamma Control
B7C	R/W	Video Processor	Vid_Sync Adjust
C00	R/W	Subpicture	Subpicture_Color0
C04	R/W	Subpicture	Subpicture_Color1
C08	R/W	Subpicture	Subpicture_Color2
C0C	R/W	Subpicture	Subpicture_Color3
C10	R/W	Subpicture	Subpicture_Color4
C14	R/W	Subpicture	Subpicture_Color5
C18	R/W	Subpicture	Subpicture_Color6
C1C	R/W	Subpicture	Subpicture_Color7
C20	R/W	Subpicture	Subpicture_Color8
C24	R/W	Subpicture	Subpicture_Color9
C28	R/W	Subpicture	Subpicture_Color10
C2C	R/W	Subpicture	Subpicture_Color11
C30	R/W	Subpicture	Subpicture_Color12
C34	R/W	Subpicture	Subpicture_Color13
C38	R/W	Subpicture	Subpicture_Color14
C3C	R/W	Subpicture	Subpicture_Color15
C40	R/W	Subpicture	Subpicture_DCI_Address
C44	R/W	Subpicture	Subpicture_HLI_Address
C50	R/W	Subpicture	Subpicture_Control
C54	R/W	Subpicture	Subpicture_Display_Offset
C58	R/W	Subpicture	Subpicture_Display_Scale
D00	RO	On Screen Display	OSD_Status
D04	R/W	On Screen Display	OSD_Control
D08	R/W	On Screen Display	OSD_Color_Number
D0C	R/W	On Screen Display	OSD_Color_Data
D10	R/W	On Screen Display	OSD_Region1_Control
D14	R/W	On Screen Display	OSD_Region1_Hlimits
D18	R/W	On Screen Display	OSD_Region1_Vlimits
D1C	R/W	On Screen Display	OSD_Region1_DramBase
D20	R/W	On Screen Display	OSD_Region2_Control
D24	R/W	On Screen Display	OSD_Region2_Hlimits

Table 4. CS98000 Registers (Continued)

D28	R/W	On Screen Display	OSD_Region2_Vlimits
D2C	R/W	On Screen Display	OSD_Region2_DramBase
D30	R/W	On Screen Display	OSD_Region3_Control
D34	R/W	On Screen Display	OSD_Region3_Hlimits
D38	R/W	On Screen Display	OSD_Region3_Vlimits
D3C	R/W	On Screen Display	OSD_Region3_DramBase
D40	R/W	On Screen Display	OSD_Blend
D44	R/W	On Screen Display	OSD_Debug1
D48	R/W	On Screen Display	OSD_Debug2
E00	R/W	PCM	PCM_Run_Clear
E04	R/W	PCM	PCM_Output_Control
E08	R/W	PCM	PCM_Out_FIFO_Start_Address
E0C	R/W	PCM	PCM_Out_FIFO_End_Address
E10	R/W	PCM	PCM_Out_FIFO_Interrupt_Address
E14	RO	PCM	PCM_Out_FIFO_Current_Address
E18	R/W	PCM	SPDIF_Channel_Status
E20	R/W	PCM	PCM_Input_Control
E24	R/W	PCM	PCM_In_FIFO_Start_Address
E28	R/W	PCM	PCM_In_FIFO_End_Address
E2C	R/W	PCM	PCM_In_FIFO_Interrupt_Address
E30	R/W	PCM	PCM_Out_FIFO_Interrupt_Address2
E34	R/W	PCM	PCM_Out_FIFO_Interrupt_Address3
E38	RO	PCM	PCM_In_FIFO_Current_Address
E3C	RW	PCM	SPDIF_Output_Control
E40	RW	PCM	SPDIF_Output_FIFO_Start_Address
E44	RW	PCM	SPDIF_Output_FIFO_End_Address
E48	RO	PCM	SPDIF_Output_FIFO_Current_Address
E4C	RW	PCM	SPDIF_Output_FIFO_Interrupt_Address
E50	RW	PCM	SPDIF_Output_Add_Block
2XXXX	R/W	RSK0	RISC 0 Processor registers
3XXXX	R/W	RSK1	RISC 1 Processor registers

Table 4. CS98000 Registers (Continued)

6. PIN DESCRIPTION

Table 5 lists the conventions used to identify the pin type and direction in the table that follows.

I	Input
IS	Input, with schmitt trigger
ID	Input, with pull down resistor
IU	Input, with pull up resistor
O	Output
O4	Output – 4mA drive
O8	Output – 8mA drive
T4	Tri-State-able Output – 4mA drive
B	Bi-direction
B4	Bi-direction – 4mA drive
B4U	Bi-direction – 4mA drive, with pull-up
B8U	Bi-direction – 8mA drive, with pull-up
B4S	Bi-direction – 4mA drive, with schmitt trigger
B4SU	Bi-direction – 4mA drive, with pull-up and schmitt trigger
Pwr	+2.5V or +3.3V power supply voltage
Gnd	Power supply ground
Name_N	Low active
Name_L	Low active

Table 5. Pin Type legend

6.1 Pin Assignments

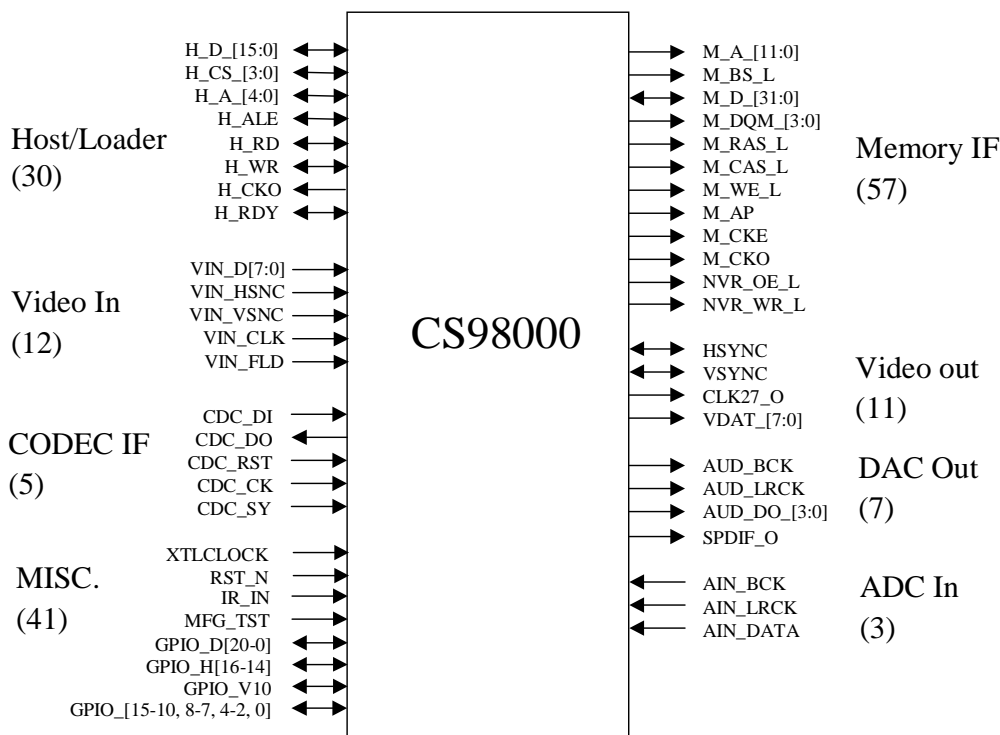
Table 6 lists the pin number, pin name and pin type for the 208 pin CS98000 package. The primary function and pin direction is shown for all signal

pins. For some signal pins, a secondary function and direction are also shown. For pins having more than one function, the primary function is chosen when the chip is reset.

Pin	Name	Type	Primary Function	Dir	Secondary Function	Dir	Note
1	VDD_PLL	Pwr	PLL Power 2.5V				
2	M_A_11	O8	SDRAM Address[11]	O	ROM/NVRAM Address[11]	O	
3	M_A_10	O8	SDRAM Address[10]	O	ROM/NVRAM Address[10]	O	
4	GPIO_D18	B4U	GenioDVD[18]	B	System Clock PLL Bypass	I	
5	M_A_9	O8	SDRAM Address[9]	O	ROM/NVRAM Address[9]	O	
6	M_A_8	O8	SDRAM Address[8]	O	ROM/NVRAM Address[8]	O	
7	M_A_7	O8	SDRAM Address[7]	O	ROM/NVRAM Address[7]	O	
8	GPIO_D16	B4SU	GenioDVD[16]	B			
9	M_A_6	O8	SDRAM Address[6]	O	ROM/NVRAM Address[6]	O	
10	M_A_5	O8	SDRAM Address[5]	O	ROM/NVRAM Address[5]	O	
11	M_A_4	O8	SDRAM Address[4]	O	ROM/NVRAM Address[4]	O	
12	GPIO_D17	B4U	GenioDVD[17]	B			
13	M_A_3	O8	SDRAM Address[3]	O	ROM/NVRAM Address[3]	O	
14	M_A_2	O8	SDRAM Address[2]	O	ROM/NVRAM Address[2]	O	
15	M_A_1	O8	SDRAM Address[1]	O	ROM/NVRAM Address[1]	O	
16	M_A_0	O8	SDRAM Address[0]	O	ROM/NVRAM Address[0]	O	
17	GPIO_D19	B4U	GenioDVD[19]	B	Memory Clock PLL Bypass	I	
18	VSS_IO	Gnd	I/O Ground				
19	M_CKO	O8	SDRAM Clock	O			
20	VDD_IO	Pwr	I/O Power 3.3V				
21	M_BS_L	O8	SDRAM Bank Select	O			
22	M_CKE	B8	SDRAM Clock Enable	O	GenioMis(7)	B	
23	M_AP	O8	SDRAM Auto Pre-charge	O			
24	M_RAS_L	O8	SDRAM Row Strobe	O			
25	M_CAS_L	O8	SDRAM Column Strobe	O			
26	GPIO_D20	B4U	GenioDVD[20]	B			
27	M_WE_L	O8	SDRAM Write Enable	O			
28	M_DQM_0	O8	SDRAM DQM[0]	O			
29	M_DQM_1	O8	SDRAM DQM[1]	O			
30	GPIO_D0	B4U	GenioDVD[0]	B			
31	M_DQM_2	O8	SDRAM DQM[2]	O			
32	M_DQM_3	O8	SDRAM DQM[3]	O			
33	M_D_8	B8U	SDRAM Data[8]	B	ROM/NVRAM Data[8]	B	
34	GPIO_D1	B4U	GenioDVD[1]	B			
35	VSS_IO	Gnd	I/O Ground				

Table 6. Pin assignments

36	VSS_CORE	Gnd	Core Ground				
37	M_D_7	B8U	SDRAM Data[7]	B	ROM/NVRAM Data[7]	B	
38	VDD_IO	Pwr	I/O Power 3.3V				
39	GPIO_D2	B4U	GenioDVD[2]	B			
40	M_D_9	B8U	SDRAM Data[9]	B	ROM/NVRAM Data[9]	B	
41	VDD_CORE	Pwr	Core Power 2.5V				
42	M_D_6	B8U	SDRAM Data[6]	B	ROM/NVRAM Data[6]	B	
43	GPIO_D3	B4U	GenioDVD[3]	B			
44	M_D_10	B8U	SDRAM Data[10]	B	ROM/NVRAM Data[10]	B	
45	M_D_5	B8U	SDRAM Data[5]	B	ROM/NVRAM Data[5]	B	
46	M_D_11	B8U	SDRAM Data[11]	B	ROM/NVRAM Data[11]	B	
47	GPIO_D4	B4U	GenioDVD[4]	B			
48	M_D_4	B8U	SDRAM Data[4]	B	ROM/NVRAM Data[4]	B	
49	M_D_12	B8U	SDRAM Data[12]	B	ROM/NVRAM Data[12]	B	
50	GPIO_D5	B4U	GenioDVD[5]	B			
51	M_D_3	B8U	SDRAM Data[3]	B	ROM/NVRAM Data[3]	B	
52	UNUSED		may leave unconnected				
53	UNUSED		may leave unconnected				
54	M_D_13	B8U	SDRAM Data[13]	B	ROM/NVRAM Data[13]	B	
55	M_D_2	B8U	SDRAM Data[2]	B	ROM/NVRAM Data[2]	B	
56	M_D_14	B8U	SDRAM Data[14]	B	ROM/NVRAM Data[14]	B	
57	GPIO_D6	B4U	GenioDVD[6]	B			
58	VSS_IO	Gnd	I/O Ground				
59	M_D_1	B8U	SDRAM Data[1]	B	ROM/NVRAM Data[1]	B	
60	M_D_15	B8U	SDRAM Data[15]	B	ROM/NVRAM Data[15]	B	
61	GPIO_D7	B4U	GenioDVD[7]	I		B	
62	M_D_0	B8U	SDRAM Data[0]	B	ROM/NVRAM Data[0]	B	
63	VSS_CORE	Gnd	Core Ground				
64	M_D_24	B8U	SDRAM Data[24]	B	ROM/NVRAM Address[20]	O	
65	GPIO_D11	B4U	GenioDVD[11]	B			
66	VDD_CORE	Pwr	Core Power 2.5V				
67	M_D_23	B8U	SDRAM Data[23]	B	ROM/NVRAM Address[19]	O	
68	M_D_25	B8U	SDRAM Data[23]	B	ROM/NVRAM Address[21]	O	
69	GPIO_D10	B4U	GenioDVD[10]	B			
70	M_D_22	B8U	SDRAM Data[22]	B	ROM/NVRAM Address[18]	O	
71	M_D_26	B8U	SDRAM Data[26]	B	ROM/NVRAM Address[22]	O	
72	M_D_21	B8U	SDRAM Data[21]	B	ROM/NVRAM Address[17]	O	
73	GPIO_D9	B4U	GenioDVD[9]	B			
74	M_D_27	B8U	SDRAM Data[27]	B	ROM/NVRAM Address[23]	O	
75	M_D_20	B8U	SDRAM Data[20]	B	ROM/NVRAM Address[16]	O	
76	M_D_28	B8U	SDRAM Data[28]	B			

Table 6. Pin assignments (Continued)

77	GPIO_D8	B4U	GenioDVD[8]	B			
78	M_D_19	B8U	SDRAM Data[19]	B	ROM/NVRAM Address[15]	O	
79	M_D_29	B8U	SDRAM Data[29]	B			
80	M_D_18	B8U	SDRAM Data[18]	B	ROM/NVRAM Address[14]	O	
81	NV_WE_L	B4U	NVRAM Write Enable	O	GenioMis[8]	B	
82	VSS_CORE	Gnd	Core Ground				
83	M_D_30	B8U	SDRAM Data[30]	B	ROM/NVRAM Decode Low	O	
84	VDD_CORE	Pwr	Core Power 2.5V				
85	H_ALE	B4U	Host Address Latch	O	GenioHst[13]	B	
86	M_D_17	B8U	SDRAM Data[18]	B	ROM/NVRAM Address[13]	O	
87	M_D_31	B8U	SDRAM Data[31]	B	ROM/NVRAM Decode High	O	
88	M_D_16	B8U	SDRAM Data[16]	B	ROM/NVRAM Address[12]	O	
89	GPIO_H14	B4U	GenioHst[14]	B			
90	NV_OE_L	O4	ROM/NVRAM Output Enable	O			
91	VDD_IO	Pwr	I/O Power 3.3V				
92	H_RD	B4S	Host Read Strobe	O	DVD Data Strobe	I	1
93	H_WR	B4	Host Write Strobe	O	DVD Data Enable	I	1
94	GPIO_H15	B4U	GenioHst[15]	B			
95	H_RDY	B4	Host Ready	I	DVD Data Ready	O	1
96	VSS_IO	Gnd	I/O Ground				
97	H_A_2	B4	Host Address[2]	O	GenioHst[10]	B	1
98	GPIO_H16	B4U	GenioHst[16]	B			
99	H_A_1	B4	Host Address[1]	O	GenioHst[9]	B	1
100	H_A_0	B4	Host Address[0]	O	GenioHst[8]	B	1
101	H_CS_1	B4	Host Chip Select [1]	O	DVD Error	I	1
102	H_A_4	B4	Host Address[4]	O	GenioHst[12]	B	1
103	VSS_CORE	Gnd	Core Ground				
104	VSS_PLL	Gnd	PLL Ground				
105	VDD_PLL	Pwr	PLL Power 2.5V				
106	H_CS_0	B4	Host Chip Select[0]	O	DVD Start Sector	I	1
107	H_A_3	B4	Host Address[3]	O	GenioHst[11]	B	1
108	VDD_CORE	Pwr	Core Power 2.5V				
109	H_D_15	B4	Host Data[15]	B	CD Data	I	1, 2
110	H_D_14	B4	Host Data[14]	B	CD Left Right Clock	I	1, 2
111	H_CS_3	B4	Host Chip Select[3]	O	GenioHst[18]	B	1
112	H_D_13	B4S	Host Data[13]	B	CD Clock	I	1, 2
113	H_D_12	B4	Host Data[12]	B	CD Error	I	1, 2
114	H_D_11	B4	Host Data[11]	B	DVD Control Data In	I	1, 2
115	H_CS_2	B4	Host Chip Select[2]	O	GenioHst[17]	B	1
116	H_D_10	B4	Host Data[10]	B	DVD Control Data Out	O	1, 2

Table 6. Pin assignments (Continued)

117	H_D_9	B4	Host Data[9]	B	DVD Control Ready	I	1, 2
118	H_D_8	B4	Host Data[8]	B	DVD Control Clock	O	1, 2
119	VSS_IO	Gnd	I/O Ground				
120	H_CKO	B4	Host Clock	O	GenioHst[19]	B	1
121	H_D_7	B4	Host Data[7]	B	DVD Data[7]	I	1
122	H_D_6	B4	Host Data[6]	B	DVD Data[6]	I	1
123	H_D_5	B4	Host Data[5]	B	DVD Data[5]	I	1
124	AUD_BCK	B4	Audio Out Bit Clock	O	GenioMis[3]	B	
125	H_D_4	B4	Host Data[4]	B	DVD Data[4]	I	1
126	VSS_CORE	Gnd	Core Ground				
127	H_D_3	B4	Host Data[3]	B	DVD Data[3]	I	1
128	AUD_LRCK	O4	Audio Out LR Clock	O			
129	VDD_CORE	Pwr	Core Power 2.5V				
130	H_D_2	B4	Host Data[2]	B	DVD Data[2]	I	1
131	VDD_IO	Pwr	I/O Power 3.3V				
132	H_D_1	B4	Host Data[1]	B	DVD Data[1]	I	1
133	AUD_DO_2	B4	Audio Out Data[2]	O	GenioMis[2]	B	
134	H_D_0	B4	Host Data[0]	B	DVD Data[0]	I	1
135	AUD_DO_0	O4	Audio Out Data[0]	O			
136	AUD_DO_1	B4	Audio Out Data[1]	O	GenioMis[1]	B	
137	AIN_BCK	IU	Audio In Bit Clock	I			
138	VSS_CORE	Gnd	Core Ground				
139	AIN_LRCK	IU	Audio In LR Clock	I			
140	AIN_DATA	B4U	Audio In Data	I	GenioMis[0]	B	
141	VDD_CORE	Pwr	Core Power 2.5V				
142	CDC_DI	IU	Serial CODEC Data In	I			
143	VSS_IO	Gnd	I/O Ground				
144	CDC_DO	T4	Serial CODEC Data Out	O			
145	VIN_CLK	IU	Video Input Clock	I			
146	CDC_RST	T4	Serial CODEC Reset	O			
147	CDC_CK	IU	Serial CODEC Bit Clock	I			
148	CDC_SY	B4U	Serial CODEC Sync	B			
149	GPIO_V10	B4U	GenioMis[26]	B			
150	GPIO_D15	B4U	GenioDvd[15]				
151	GPIO_D14	B4U	GenioDvd[14]				
152	GPIO_D13	B4SU	GenioDvd[13]				
153	VIN_VSNC	B4U	Video Input Vsync	I	GenioMis[25]	B	
154	CLK27_O	B4U	Video Output Clock	O	GenioMis[6]	B	
155	GPIO_D12	B4U	GenioDvd[12]				
156	VDD_PLL	Pwr	PLL Power 2.5V				
157	VSS_PLL	Gnd	PLL Ground				

Table 6. Pin assignments (Continued)

158	VSS_CORE	Gnd	Core Ground				
159	HSYNC	B4U	Video Output Hsync	O	GenioMis[4]	B	
160	VIN_HSYNC	B4U	Video Input Hsync	I	GenioMis[24]	B	
161	VDD_CORE	Pwr	Core Power 2.5V				
162	VSYNC	B4U	Video Output Vsync	O	GenioMis[5]	B	
163	VDAT_0	O4	Video Output Data[0]	O			
164	VIN_D0	B4U	Video Input Data[0]	I	GenioMis[16]	B	
165	VDAT_1	O4	Video Output Data[1]	O			
166	VDAT_2	O4	Video Output Data[2]	O			
167	VDAT_3	O4	Video Output Data[3]	O			
168	VIN_D1	B4U	Video Input Data[1]	I	GenioMis[17]	B	
169	VDAT_4	O4	Video Output Data[4]	O			
170	VDAT_5	O4	Video Output Data[5]	O			
171	UNUSED		may leave unconnected				
172	VDAT_6	O4	Video Output Data[6]	O			
173	VDAT_7	O4	Video Output Data[7]	O			
174	GPIO_0	B4U	General Purpose IO[0]	B	Audio PLL Input Bypass	I	
175	VIN_D2	B4U	Video Input Data[2]	I	GenioMis[18]	B	
176	VSS_CORE	Gnd	Core Ground				
177	AUD_DO_3	B4U	Audio Out Data[3]	O	General Purpose IO[1]	B	
178	VDD_CORE	Pwr	Core Power 2.5V				
179	VIN_D3	B4U	Video Input Data[3]	I	GenioMis[19]	B	
180	VDD_IO	Pwr	I/O Power 3.3V				
181	GPIO_2	B4U	General Purpose IO[2]	B			
182	VSS_IO	Gnd	I/O Ground				
183	GPIO_3	B4U	General Purpose IO[3]	B			
184	VIN_D4	B4U	Video Input Data[4]	I	GenioMis[20]	B	
185	GPIO_4	B4U	General Purpose IO[4]	B			
186	SCL	B4U	I ² C Clock	B	General Purpose IO[5]	B	
187	SDA	B4U	I ² C Data	B	General Purpose IO[6]	B	
188	GPIO_7	B4U	General Purpose IO[7]	B			
189	VIN_D5	B4U	Video Input Data[5]	I	GenioMis[21]	B	
190	GPIO_8	B4U	General Purpose IO[8]	B			
191	AUD_XCLK	B4U	Audio 256x/384x Clock	B	General Purpose IO[9]	B	
192	GPIO_10	B4U	General Purpose IO[10]	B			
193	VIN_D6	B4U	Video Input Data[6]	I	GenioMis[22]	B	
194	GPIO_11	B4U	General Purpose IO[11]	B			
195	GPIO_12	B4U	General Purpose IO[12]	B			
196	GPIO_13	B4U	General Purpose IO[13]	B			
197	GPIO_14	B4U	General Purpose IO[14]	B			
198	VIN_D7	B4U	Video Input Data[7]	I	GenioMis[23]	B	

Table 6. Pin assignments (Continued)

199	GPIO_15	B4U	General Purpose IO[15]	B			
200	VSS_CORE	Gnd	Core Ground				
201	IR_IN	IS	Infrared input	I			
202	XTLCLOCK	I	27 MHz Clock In	I			
203	VDD_CORE	Pwr	Core Power 2.5V				
204	SPDIF_O	O4	S/PDIF Out	O			
205	RST_N	IS	Reset In	I			
206	MFG_TEST	I	(Tie to ground)	I			
207	VIN_FLD	ID	Video Input Field				
208	VSS_PLL	Gnd	PLL Ground				

Table 6. Pin assignments (Continued)

- Notes: 1. Pin may be used for micro-less DVD loader interface
 2. H_D(15:8) pins may be reassigned as GenIOHst(7:0)

6.2 Miscellaneous Interface Pins

These pins are used for used for basic functions such as clock and reset input. The I²C are used for both master and slave mode (8-bit slave address is 0x30 for write, and 0x31 for read).

6.3 SDRAM Interface

These pins are used to interface the CS98000 with some external SDRAM. The CS98000 can interface with SDRAM of various size. Both 16 and 32 bit data width is supported, but best performance is achieved with 32 bits. Follow instructions in the following table on how to interface any particular configuration of SDRAM.

6.4 ROM/NVRAM Interface

This is the interface to the non-volatile memory that contains the firmware. It could be either ROM, NVRAM – FLASH or EEPROM - or any combination of those. This interface can also connect to SRAM that would emulate a ROM on a development system. The bus width is eight or 16 bits. Except for the NVM_WE_L and NVM_OE_L pins, all these pins are shared with the DRAM interface, which operates simultaneously with the ROM/NVRAM interface.

Pin	Signal Name	Type	Description
186	SCL	B	I ² C Clock
187	SDA	B	I ² C Data
201	IR_IN	I	Infrared Input, from IR receiver.
202	XTLCLOCK	I	27 MHz Clock Input.
205	RST_N	I	Reset Input, active low.
206	MFG_TEST	I	Manufacturing test pin, should always connect to ground.

Table 7. Miscellaneous Interface Pins

Pin	Signal Name	Type	Description
87, 83, 79, 76, 74, 71, 68, 64, 67, 70, 72, 75, 78, 80, 86, 88, 60, 56, 54, 49, 46, 44, 40, 33, 37, 42, 45, 48, 51, 55, 59, 62	M_D[31..0]	B	Memory Data Bus. CS98000 can use all 32 bits or can use only M_D[15..0], in which case M_D[31..16] can be left un-connected.
2, 3, 5, 6, 7, 9, 10, 11, 13, 14, 15, 16	M_A[11..0]	O	Memory Address Bus. Connect in order starting with M_A[0] to all RAM address pins not already connected to M_BS_L or M_AP. Unused upper M_A pins unconnected.
19	M_CKO	O	Memory Clock
22	M_CKE	O	Memory Clock Enable
21	M_BS_L	O	Bank Selection. Always connect to RAM BS or BS0 pin.
23	M_AP	O	Memory Auto Pre-charge. Always connect to RAM AP pin.
24	M_RAS_L	O	Memory Row Address Strobe
25	M_CAS_L	O	Memory Column Address Strobe
27	M_WE_L	O	Memory Write Enable
32, 31, 29, 28	M_DQM[3..0]	O	IO Mask of Data Bus M_DQM[3] -> M_D[31:24]

Table 8. SDRAM Interface

Pin	Signal Name	Type	Description
60, 56, 54, 49, 46, 44, 40, 33, 37, 42, 45, 48, 51, 55, 59, 62	M_D[15..0]	B	Memory Data Bus. Use M_D[7:0] for 8-bit interface
2, 3, 5, 6, 7, 9, 10, 11, 13, 14, 15, 16	M_A[11..0]	O	Memory Address Bus[11..0]
74, 71, 68, 64, 67, 70, 72, 75, 78, 80, 86, 88	M_D[27..16]	O	Memory Address Bus[23..12] For 16-bit data mode, M_D[26:16] is upper word address. For 8-bit data mode, M_D[27:16] is upper byte address.
83	M_D[30]	O	Address decode low. Copy of address MSB.
87	M_D[31]	O	Address decode high. Compliment of address MSB.
60	NVM_WE_L	O	NVRAM Write Enable.
62	NVM_OE_L	O	ROM/NVRAM Output Enable.

Table 9. ROM/NVRAM Interface

6.5 Video Output Interface

This is the interface to a video encoder chip that will send the CS98000 video signals to a TV. The output format is either CCIR-601 or CCIR-656. The CS98000 supports both master and slave configuration. For CCIR-656 mode, the CS98000 must

be the sync master. In this case, the HSYNC and VSYNC pins can be redefined as GPIOs.

6.6 Video Input Interface

The CS98000 support CCIR-601, CIF and QCIF video input format through this interface.

Pin	Signal Name	Type	Description
154	CLK27_O	O	27 Mhz Clock Output.
159	HSYNC	B	Horizontal Sync. Output when the CS98000 is the video master, input when the video encoder is master.
162	VSYNC	B	Vertical Sync. Output when the CS98000 is the video master, input when the video encoder is master.
173, 172, 170, 169, 167, 166, 165, 163	VDAT[7..0]	O	Video Data Output[7..0] in Cb,Y,Cr,Y format.

Table 10. Video Output Interface

Pin	Signal Name	Type	Description
145	VIN_CLK	I	Video Input Clock.
153	VIN_VSNC	I	Video Input Vertical Sync.
160	VIN_HSNC	I	Video Input Horizontal Sync.
207	VIN_FLD	I	Video Input Clock.
198, 193, 189, 184, 179, 175, 168, 164	VIN_D [7..0]	I	Video Data Input[7..0] in Cb,Y,Cr,Y format.

Table 11. Video Input Interface

6.7 Audio Output/Input Interface

This is the audio PCM interface that connects to an audio CODEC. The sample rate and the size of the samples are programmable for both input and output direction.

6.8 AC97/CODEC Interface

This serial interface could be used either as a second PCM CODEC interface or as an AC97 serial link to an AC97 compliant CODEC. This could control a modem, or a second set of audio channels.

Pin	Signal Name	Type	Description
191	AUD_XCLK	B	Audio 256x/384x Clock input or output to Serial DAC. When output, is generated from CS98000 internal PLL.
124	AUD_BCK	O	Audio Bit Clock output to serial DAC.
128	AUD_LRCK	O	Audio Out Left/Right Clock to serial DAC.
135	AUD_DO_0	O	Audio Serial Data Out[0].
136	AUD_DO_1	O	Audio Serial Data Out[1].
133	AUD_DO_2	O	Audio Serial Data Out[2].
177	AUD_DO_3	O	Audio Serial Data Out[3].
204	SPDIF_O	O	S/PDIF Output
137	AIN_BCK	I	Audio Input Bit Clock. The CS98000 can be programmed to use the Audio Output function's internally generated bit clock, in which case this pin is not required.
139	AIN_LRCK	I	Audio Input Left/Right Clock. The CS98000 can be programmed to use the Audio Output function's internally generated LR clock, in which case this pin is not required.
140	AIN_DATA	I	Audio Input Data from Serial ADC.

Table 12. Audio Output Interface

Pin	Signal Name	Type	Description
142	CDC_DI	I	Serial Data Input from Modem CODEC
144	CDC_DO	O	Serial Data Output to Modem CODEC
146	CDC_RST	O	Reset Output to Modem CODEC
147	CDC_CK	I	Serial Bit Clock input from Modem CODEC
148	CDC_SY	B	Frame Sync, output when CS98000 is master, input when CODEC is master.

Table 13. AC97/CODEC Interface

6.9 Host Master/ATAPI Interface

This 16 bits parallel host interface allows the CS98000 to be a host master, controlling other devices that would be used on the same system. The interface supports a programmable protocols and speeds, including multiplexed and non-multiplexed addressing. Slaves with different protocols can be connected at the same time, controlled by different chip selects.

6.10 DVD I/O Channel Interface

This interface connects to standard DVD loaders, and consists of three parts: Control, DVD Data and CD Data. This interface shares CS98000 pins with the Host Master/ATAPI interface. The definition of the pins is set via register programming, and the two modes are mutually exclusive.

6.11 General Purpose Input/Output (GPIO)

The CS98000 provides 37 GPIO pins, each with individual output tri-state controls. Additional pins may also be re-defined and GPIO's.

6.12 Power and Ground

The CS98000 requires 3 different types of power supplies – PLLs, internal logic and IO pins -. The PLLs and internal logic use 2.5 V power supply, The IO pins use 3.3 V power supply, and are 5 V input tolerant.

Schematic & Layout Review Service

Confirm Optimum Schematic & Layout Before Building Your Board.

For Our Free Review Service Call Applications Engineering.

Call : (5 1 2) 4 4 5 - 7 2 2 2

Pin	Signal Name	Type	Description
111, 115, 101, 106	H_CS[3..0]	O	Host Chip Select{3..0}. The host master can be programmed to use a different protocol for each of the 4 chip selects
85	H_ALE	O	Host address latch enable. Used for modes which multiplex upper address information onto the data lines
92	H_RD	O	Host Read Request.
93	H_WR	O	Host Write Request.
95	H_RDY	I	Host Ready. Connect to pull-up or pull-down if host is not used.
120	H_CKO	O	Host clock out, required for some synchronous slaves
102, 107, 97, 99, 100	H_A[4..0]	O	Host Address[4..0].
109, 110, 112, 113, 114, 116, 117, 118, 121, 122, 123, 125, 127, 130, 132, 134	H_D[15..0]	B	Host Data Bus[15..0]. These pins can also output Host Address during the address phase for multiplexed address/data mode. Tie together to pull-up or pull-down if host is not used.

Table 14. Host Master Interface

Pin	Signal Name	Type	Description
121, 122, 123, 125, 127, 130, 132, 134	H_D[7:0]	I	DVD_Data[7:0] – DVD data port parallel data input from loader
118	H_D[8]	O	Control port clock to loader
117	H_D[9]	I	Control port ready signal from loader
116	H_D[10]	O	Control port serial command to loader
114	H_D[11]	I	Control port serial status from loader
113	H_D[12]	I	CD error signal from loader
112	H_D[13]	I	CD clock from loader
110	H_D[14]	I	CD left/right clock from loader
109	H_D[15]	I	CD serial data from loader
106	H_CS_0	I	DVD data start sector signal from loader
101	H_CS_1	I	DVD data error signal from loader
95	H_RDY	O	DVD data ready signal to loader
93	H_WR	I	DVD data enable signal from loader
92	H_RD	I	DVD data clock from loader

Table 15. DVD I/O Channel Interface

Pin	Signal Name	Type	Description
26, 17, 4, 12, 8, 150, 151, 152, 155, 65, 69, 73, 77, 61, 57, 50, 47, 43, 39, 34, 30	GPIO_D[20:0]	B	21 General purpose I/O's
98, 94, 89	GPIO_H[16:14]	B	3 General purpose I/O's
149	GPIO_V10	B	General purpose I/O
199, 197, 196, 195, 194, 192	GPIO_[15:10]	B	6 General purpose I/O's
190, 188	GPIO_[8:7]	B	2 General purpose I/O's
195, 183, 181	GPIO_[4:2]	B	3 General purpose I/O's
174	GPIO_0	B	General purpose I/O

Table 16. General Purpose I/O Interface

Pin	Signal Name	Type	Description
1, 105, 158	VDD_PLL		2.5V for internal PLLs
41, 66, 84, 108, 129, 141, 161, 178, 203	VDD_CORE		2.5V for internal core logic
20, 38, 91, 131, 180	VDD_IO		3.3V for I/O's
104, 157, 208	VSS_PLL		Ground for internal PLLs
36, 63, 82, 103, 126, 138, 158, 176, 200	VSS_CORE		Ground for internal core logic
18, 35, 58, 96, 119, 143, 182	VSS_IO		Ground for I/O's

Table 17. Power and Ground

7. PACKAGE SPECIFICATIONS

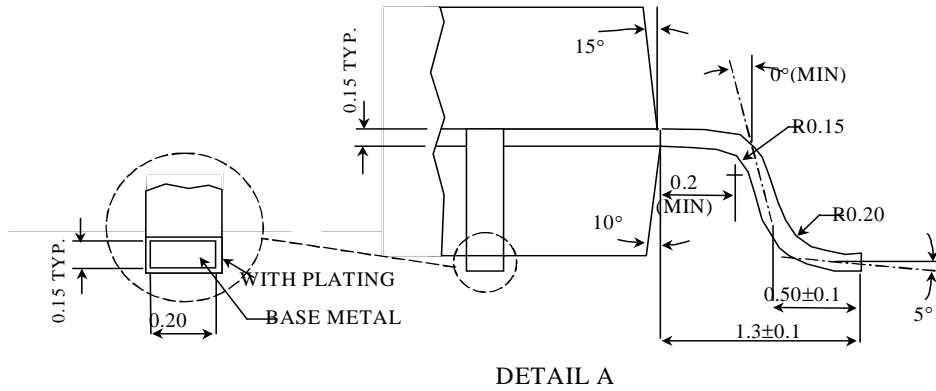
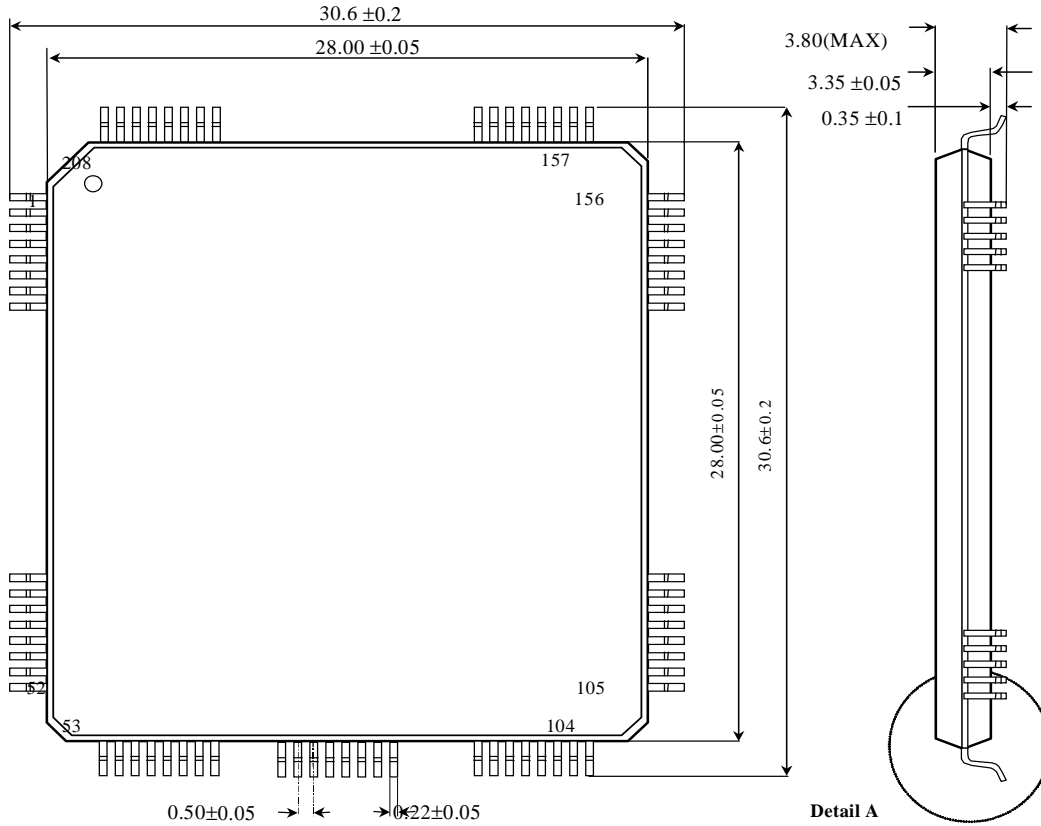

• **Notes** •

SMART
Analog™