

P.C.B. MOUNTING

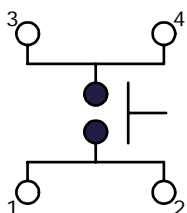
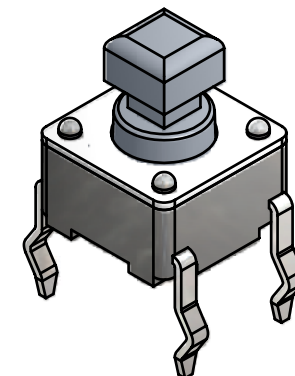
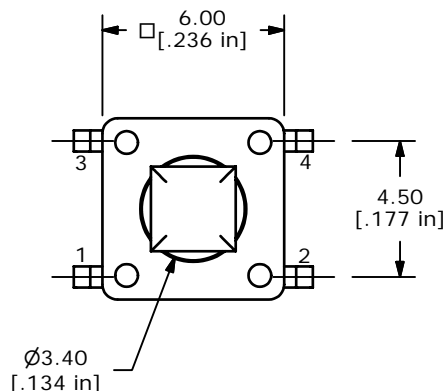

CIRCUIT: SPST

NOTES:

1. ALL DIMENSIONS IN MM [INCH]
2. TERMINAL NUMBERS FOR REF. ONLY
3. TOLERANCE: X.X=±0.4
X.XX=±0.25
- ▲ 4. MATERIAL: CONTACTS: SILVER
HOUSING AND ACTUATOR:
TO MEET UL94VO
5. RATING: 12VDC @ 50mA
6. TRAVEL: 0.25 +0.2/-0.1
- ▲ 7. OPERATING FORCE: 160± 50
8. ELECTRICAL LIFE: 100,000 LIFE CYCLES
9. CONTACT RESISTANCE: 100mΩ MAX.
10. ▲ DENOTES CRITICAL PARAMETER
11. 2002/95/EC (ROHS) COMPLIANT
- ▲ 12. PACKAGING: 750PCS/POLY BAG

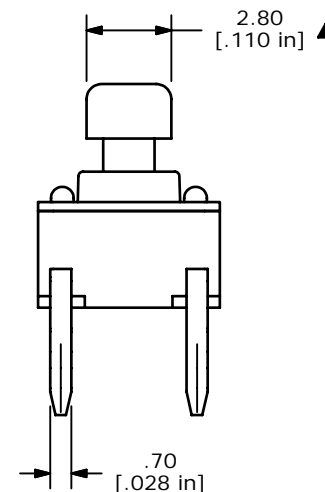
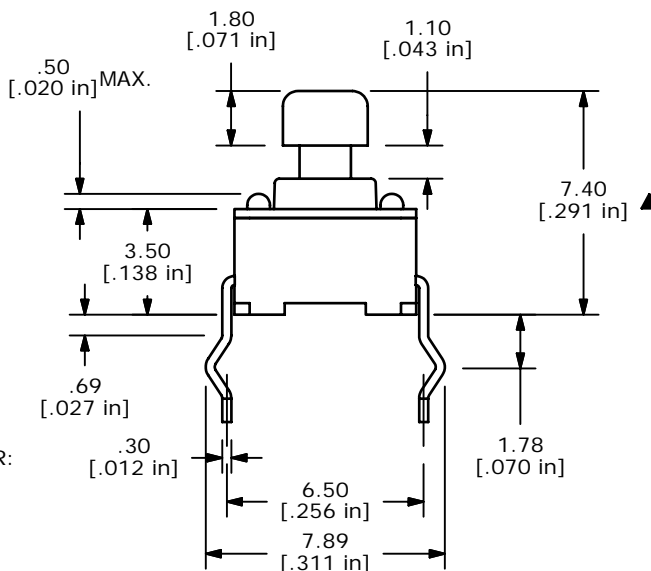

E-SWITCH®

TITLE TL1105SPF160Q94VO

A	16181	NEW PART RELEASE	7/7/06	CT
REV	PCR NO	DESCRIPTION	DATE	BY

THE INFORMATION CONTAINED IN THIS DOCUMENT IS PROPRIETARY TO E-SWITCH AND IS NOT TO BE COPIED OR TRANSFERRED

SCALE	DATE	DR	DWG	REV
4:1	7/7/2006	CT	P010213	A