

RECOMMENDED PANEL MOUNTING

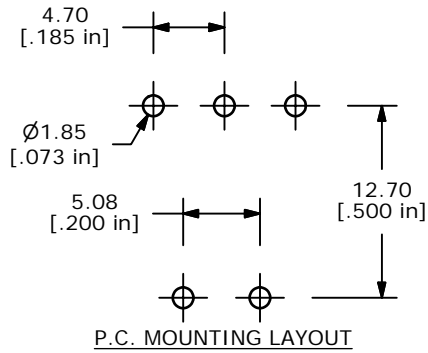

P.C. MOUNTING LAYOUT

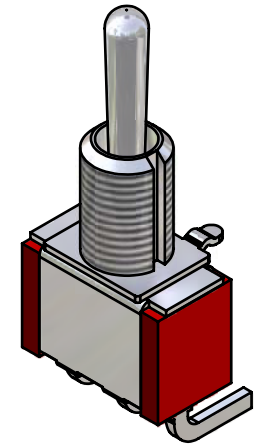
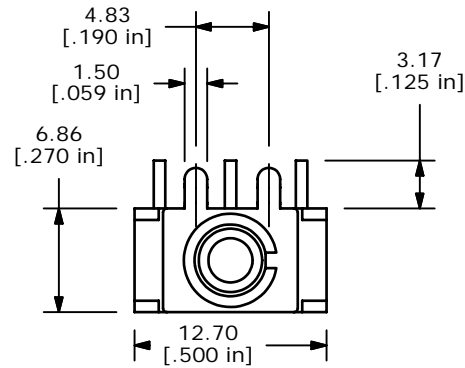

ISOMETRIC

SWITCH FUNCTION		
POS. 1	POS. 2	POS. 3
ON	OFF	ON
2-3	OPEN	2-1

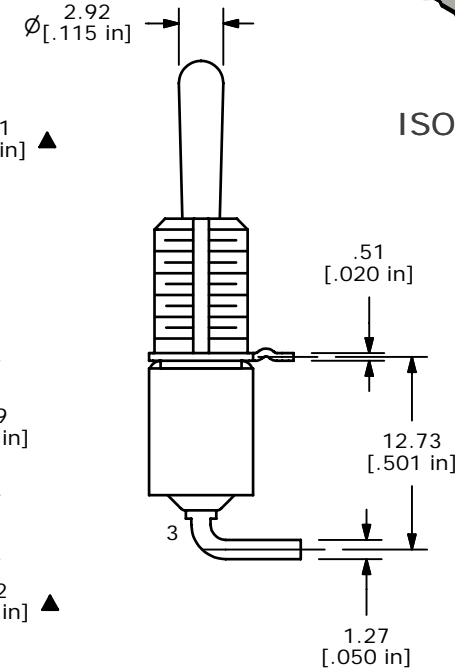
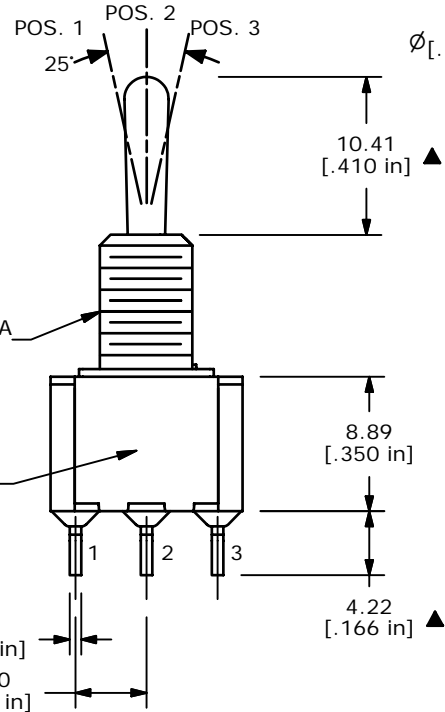
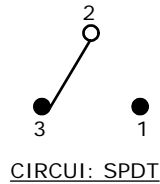

NOTE:

1. ALL DIMENSIONS IN MM [INCH]
2. GENERAL TOLERANCE: X.X=±0.4
X.XX=±0.25
3. TERMINAL NUMBERS FOR REF ONLY
- ▲ 4. PLATING MATERIAL: SILVER
5. RATING: 5A @120VAC OR 28VDC
2A @250VAC
6. ELECTRIC LIFE: 40,000 MAKE-AND-BREAK CYCLES
AT FULL LOAD.
7. INSULATION RESISTANCE: 1,000 MEGA-OHM MIN.
8. DIELECTRIC STRENGTH: 1,000 V RMS @SEA LEVEL.
9. OPERATING TEMP.: -30°C to 85°C
10. ▲ DENOTES CRITICAL PARAMETER.
11. 2002/95/EC (ROHS) COMPLIANT

E-SWITCH®

A	16036	NEW PART RELEASE	5/22/06	CT
REV	PCR NO	DESCRIPTION	DATE	BY

TITLE 100SP3T1B1M61QE				
SCALE	DATE	DR	DWG	REV
2:1	5/22/2006	CT	T113000	A

THE INFORMATION CONTAINED IN THIS DOCUMENT IS PROPRIETARY TO E-SWITCH AND IS NOT TO BE COPIED OR TRANSFERRED