

ML9289-xx

Vacuum fluorescent display tube controller driver

GENERAL DESCRIPTION

The ML9289-xx is an alphanumeric type vacuum fluorescent display (VFD) tube controller driver IC which can display alphanumeric characters, symbols, and bar charts.

Vacuum fluorescent display tube drive signals are generated by serial data sent from a micro-controller. A display system is easily realized by internal ROM and RAM for character display.

-01 is available as a general-purpose code.

Custom codes are provided on customer's request.

FEATURES

- Logic power supply (V_{DD}) : 3.3 V \pm 10% or 5.0 V \pm 10%
- Vacuum fluorescent display tube driving power supply (V_{DISP}) : 20V to 42V
- VFD driver output current
(VFD driver output can be connected directly to the VFD tube. No pull-down resistor is required.)
 - Segment driver (SEG1–16) : –6 mA ($V_{DISP} = 42$ V)
 - Segment driver (AD1, 2) : –15 mA ($V_{DISP} = 42$ V)
 - Grid driver (COM1–16) : –30 mA ($V_{DISP} = 42$ V)
- Content of display
 - CGROM : 16 segments 240 types (character data)
 - CGRAM : 16 segments 16 types (character data)
 - ADRAM : 16 (display digit) \times 2 bits (symbol data)
 - DCRAM : 16 (display digit) \times 8 bits (register for character data display)
- Display control function
 - Display digits : 1 to 16 digits
 - Display duty (brightness adjustment) : 16 stages
 - All display lights ON/OFF
- Four interfaces with microcontroller: \overline{DA} , \overline{CS} , \overline{CP} , \overline{RESET}
- Instruction executable with 1 byte (excluding data write for each RAM)
- Built-in oscillation circuit (resistor & capacitor connected externally)
- Package options:
 - AL-Pad Chip (ML9289-xxWA)
 - 44-pin plastic QFP (QFP44-P-910-0.80-2K) (ML9289-xxGA)
 - 48-pin plastic TQFP (TQFP48-P-0707-0.50-K) (ML9289-xxTB)

BLOCK DIAGRAM

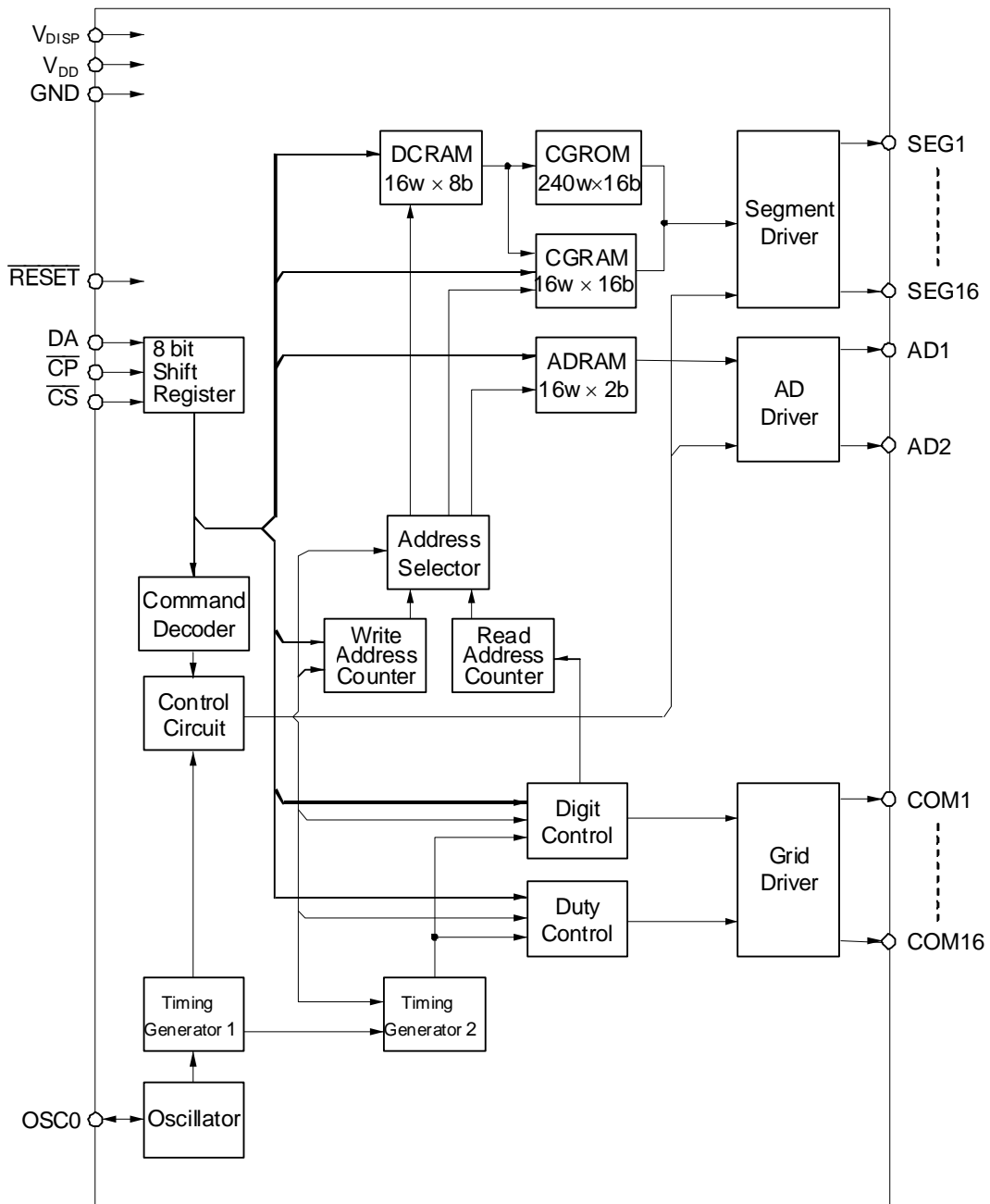

PIN CONFIGURATION (TOP VIEW)

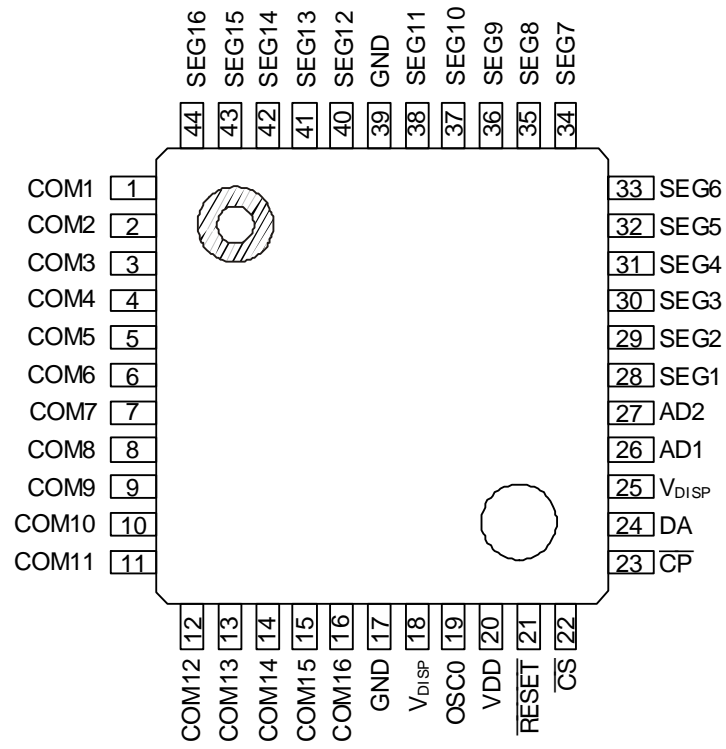

44-Pin Plastic QFP

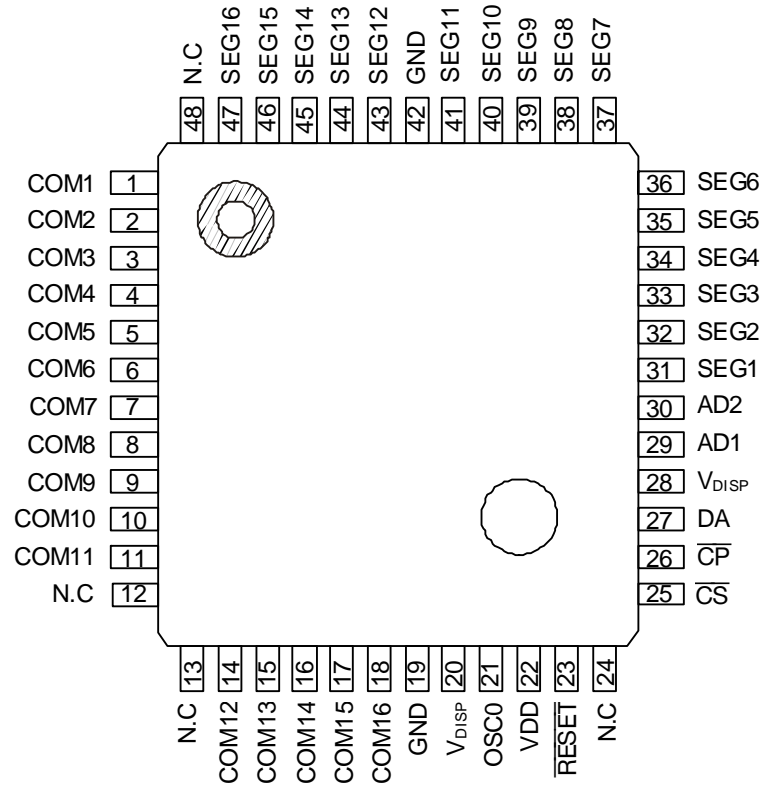

N.C.: No-Connection pin

48-Pin Plastic TQFP

PIN CONFIGURATION

Pad Layout

Chip Size: 2.30 × 3.20 mm
 Chip Thickness: 280 ±30 μm
 Pad Size: Metal 90 × 90 μm, PV Pad hole 70 × 70 μm

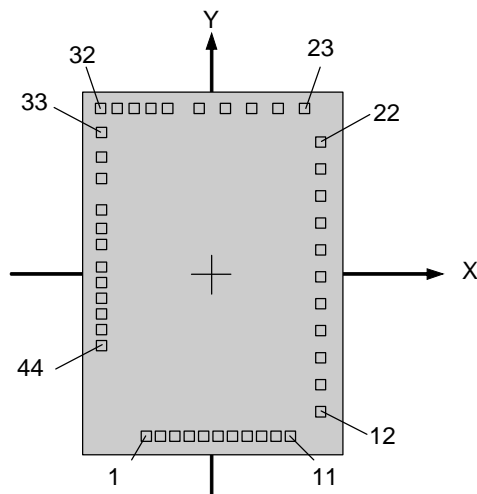

Pad Coordinates

Pad No	Symbol	X (μm)	Y (μm)	Pad No	Symbol	X (μm)	Y (μm)
1	SEG7	-638	-1465	23	COM12	811	1465
2	SEG8	-522	-1465	24	COM13	567	1465
3	SEG9	-406	-1465	25	COM14	323	1465
4	SEG10	-290	-1465	26	COM15	79	1465
5	SEG11	-174	-1465	27	COM16	-165	1465
6	GND	-39	-1465	28	GND	-435	1465
7	SEG12	91	-1465	29	VDISP	-575	1465
8	SEG13	207	-1465	30	OSC0	-715	1465
9	SEG14	323	-1465	31	VDD	-855	1465
10	SEG15	439	-1465	32	RESET	-1015	1465
11	SEG16	555	-1465	33	CS	-1015	1225
12	COM1	1015	-1308	34	CP	-1015	985
13	COM2	1015	-1064	35	DA	-1015	745
14	COM3	1015	-820	36	VDISP	-1015	415
15	COM4	1015	-576	37	AD1	-1015	196
16	COM5	1015	-332	38	AD2	-1015	65
17	COM6	1015	-88	39	SEG1	-1015	-123
18	COM7	1015	156	40	SEG2	-1015	-253
19	COM8	1015	400	41	SEG3	-1015	-383
20	COM9	1015	644	42	SEG4	-1015	-513
21	COM10	1015	888	43	SEG5	-1015	-643
22	COM11	1015	1132	44	SEG6	-1015	-773

PIN DESCRIPTION

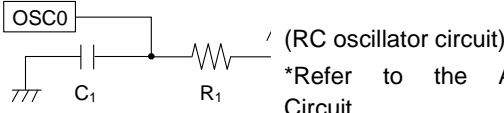
Pin		Symbol	Type	Connects to	Description
QFP	TQFP				
28-38, 40-44	31-41, 43-47	SEG1-16	O	VFD tube anode electrode	VFD tube anode electrode drive output. Directly connected to the VFD tube and no pull-down resistor is required. $I_{OH} > -6$ mA
1-16	1-11, 14-18	COM1-16	O	VFD tube grid electrode	VFD tube grid electrode drive output. Directly connected to the VFD tube and no pull-down resistor is required. $I_{OH} > -30$ mA
26, 27	29,30	AD1-2	O	VFD tube anode electrode	VFD tube anode electrode drive output. Directly connected to the VFD tube and no pull-down resistor is required. $I_{OH} > -15$ mA
18, 25	20,28	V_{DISP}	—	Power supply	The voltage supply between V_{DD} and GND is for the power supply for the internal logic. The voltage supply between V_{DISP} and GND is for the power supply for driving the VFD tube. Apply power to V_{DD} first, then to V_{DISP} .
20	22	V_{DD}			
17,39	19,42	GND			
24	27	DA	I	Microcontroller	Serial data input pin. Data is input from the LSB.
23	26	\overline{CP}	I	Microcontroller	Shift clock input pin. Serial data is shifted in on a rising edge of \overline{CP} when \overline{CS} pin is "L" level.
22	25	\overline{CS}	I	Microcontroller	Chip select input pin. Serial data transfer is enabled when \overline{CS} pin is "L" level.
21	23	\overline{RESET}	I	Microcontroller	Reset input. Setting this pin to "Low" initializes all the functions. Initial status is as follows. <ul style="list-style-type: none"> • Address of each RAM Address "00"H • Data of each RAM.....Content is undefined • Display digit.....16 digits • Brightness adjustment0/16 • All display lights ON or OFF OFF mode • All outputs Low level
19	21	OSC0	I/O	C_1, R_1	Pin for RC oscillation. Resistors and capacitors are connected externally and constants vary depending on the V_{DD} voltage used. The target oscillation frequency is 2MHz. 
-	12,13, 24,48	N.C	-	Open	No-Connection pin.

ABSOLUTE MAXIMUM RATINGS

Parameter	Symbol	Condition	Rating	Unit
Supply Voltage (1)	V _{DD}	—	−0.3 to +6.5	V
Supply Voltage (2)	V _{DISP}	—	−0.3 to +45	V
Input Voltage	V _{IN}	—	−0.3 to V _{DD} +0.3	V
Power Dissipation	P _D	T _a ≥ 25°C 44-pin plastic QFP	541	mW
Storage Temperature	T _{STG}	—	−55 to +150	°C
Output Current	I _{O1}	COM1–16	−40 to 0.0	mA
	I _{O2}	AD1–2	−20 to 0.0	mA
	I _{O3}	SEG1–16	−10 to 0.0	mA

RECOMMENDED OPERATING CONDITIONS-1

- When the unit power supply voltage is 5.0 V (typ.)

Parameter	Symbol	Condition	Min.	Typ.	Max.	Unit
Supply Voltage (1)	V _{DD}	—	4.5	5.0	5.5	V
Supply Voltage (2)	V _{DISP}	—	20	—	42	V
High Level Input Voltage	V _{IH}	All input pins except OSC0	0.7 V _{DD}	—	—	V
Low Level Input Voltage	V _{IL}	All input pins except OSC0	—	—	0.3 V _{DD}	V
CP frequency	f _C	—	—	—	2.0	MHz
Self-oscillation frequency	f _{OSC}	R ₁ = 8.2 kΩ±5%, C ₁ = 82 pF±5%	1.4	2.0	2.6	MHz
Frame Frequency	f _{FR}	DIGIT = 1 to 16, R ₁ = 8.2 kΩ±5%, C ₁ = 82 pF±5%	170	244	318	Hz
Operating Temperature	T _{op}	44-pin plastic QFP	−40	—	85	°C
	T _j	AL-Pad Chip	−40	—	105	

RECOMMENDED OPERATING CONDITIONS-2

- When the unit power supply voltage is 3.3 V (typ.)

Parameter	Symbol	Condition	Min.	Typ.	Max.	Unit
Supply Voltage (1)	V _{DD}	—	3.0	3.3	3.6	V
Supply Voltage (2)	V _{DISP}	—	20	—	42	V
High Level Input Voltage	V _{IH}	All input pins except OSC0	0.8 V _{DD}	—	—	V
Low Level Input Voltage	V _{IL}	All input pins except OSC0	—	—	0.2 V _{DD}	V
CP frequency	f _C	—	—	—	2.0	MHz
Self-oscillation frequency	f _{OSC}	R ₁ = 6.8 kΩ±5%, C ₁ = 82 pF±5%	1.4	2.0	2.6	MHz
Frame Frequency	f _{FR}	DIGIT = 1 to 16, R ₁ = 6.8 kΩ±5%, C ₁ = 82 pF±5%	170	244	318	Hz
Operating Temperature	T _{op}	44-pin plastic QFP	−40	—	85	°C
	T _j	AL-Pad Chip	−40	—	105	

ELECTRICAL CHARACTERISTICS

DC Characteristics-1

($V_{DD}=5.0V\pm 10\%$, $V_{DISP}=42V$, $T_a=-40\text{to}+85^\circ\text{C}$, unless otherwise specified)

Parameter	Symbol	Applied pin	Condition	Min.	Max.	Unit	
High Level Input Voltage	V_{IH}	\overline{CS} , \overline{CP} , DA, \overline{RESET}	—	$0.7 V_{DD}$	—	V	
Low Level Input Voltage	V_{IL}	\overline{CS} , \overline{CP} , DA, \overline{RESET}	—	—	$0.3 V_{DD}$	V	
High Level Input Current	I_{IH}	\overline{CS} , \overline{CP} , DA, \overline{RESET}	$V_{IH} = V_{DD}$	-1.0	1.0	μA	
Low Level Input Current	I_{IL}	\overline{CS} , \overline{CP} , DA, \overline{RESET}	$V_{IL} = 0V$	-1.0	1.0	μA	
High Level Output Voltage	V_{OH1}	COM1-16	$I_{OH1} = -30\text{mA}$	$V_{DISP} - 1.5$	—	V	
	V_{OH2}	AD1-2	$I_{OH2} = -15\text{mA}$	$V_{DISP} - 1.5$	—	V	
	V_{OH3}	SEG1-16	$I_{OH3} = -6\text{mA}$	$V_{DISP} - 1.5$	—	V	
Low Level Output Voltage	V_{OL1}	COM1-16 AD1-2 SEG1-16	—	—	1.0	V	
Supply Current	I_{DD1}	V_{DD}	$f_{osc} = 2\text{ MHz}$, no load	Duty = 15/16 Digit = 1-16 All output lights ON	—	3	mA
	I_{DD2}			Duty = 0/16 Digit = 1-8 All output lights OFF	—	3	mA
	I_{DISP1}	V_{DISP}	$f_{osc} = 2\text{ MHz}$, no load	Duty = 15/16 Digit = 1-16 All output lights ON	—	1	mA
	I_{DISP2}			Duty = 0/16 Digit = 1-8 All output lights OFF	—	0.1	mA

DC Characteristics-2

(V_{DD}=3.3V±10%, V_{DISP}=42V, Ta=-40to+85°C, unless otherwise specified)

Parameter	Symbol	Applied pin	Condition	Min.	Max.	Unit	
High Level Input Voltage	V _{IH}	\overline{CS} , \overline{CP} , DA, \overline{RESET}	—	0.8 V _{DD}	—	V	
Low Level Input Voltage	V _{IL}	\overline{CS} , \overline{CP} , DA, \overline{RESET}	—	—	0.2 V _{DD}	V	
High Level Input Current	I _{IH}	\overline{CS} , \overline{CP} , DA, \overline{RESET}	V _{IH} = V _{DD}	-1.0	1.0	μA	
Low Level Input Current	I _{IL}	\overline{CS} , \overline{CP} , DA, \overline{RESET}	V _{IL} = 0V	-1.0	1.0	μA	
High Level Output Voltage	V _{OH1}	COM1-16	I _{OH1} = -30mA	V _{DISP} - 1.5	—	V	
	V _{OH2}	AD1-2	I _{OH2} = -15mA	V _{DISP} - 1.5	—	V	
	V _{OH3}	SEG1-16	I _{OH3} = -6mA	V _{DISP} - 1.5	—	V	
Low Level Output Voltage	V _{OL1}	COM1-16 AD1-2 SEG1-16	—	—	1.0	V	
Supply Current	I _{DD1}	V _{DD}	f _{osc} = 2 MHz, no load	Duty = 15/16 Digit = 1-16 All output lights ON	—	2	mA
	I _{DD2}			Duty = 0/16 Digit = 1-8 All output lights OFF	—	2	mA
	I _{DISP1}	V _{DISP}	f _{osc} = 2 MHz, no load	Duty = 15/16 Digit = 1-16 All output lights ON	—	1	mA
	I _{DISP2}			Duty = 0/16 Digit = 1-8 All output lights OFF	—	0.1	mA

AC Characteristics-1(V_{DD}=5.0V±10%, V_{DISP}=42V, Ta=-40to+85°C, unless otherwise specified)

Parameter	Symbol	Condition	Min.	Max.	Unit	
$\overline{\text{CP}}$ Frequency	f _C	—	—	2.0	MHz	
$\overline{\text{CP}}$ Pulse Width	t _{CW}	—	250	—	ns	
DA Setup Time	t _{DS}	—	250	—	ns	
DA Hold Time	t _{DH}	—	250	—	ns	
$\overline{\text{CS}}$ Setup Time	t _{CSS}	—	250	—	ns	
$\overline{\text{CS}}$ Hold Time	t _{CSH}	R ₁ = 8.2 kΩ±5%, C ₁ = 82 pF±5%	16	—	μs	
$\overline{\text{CS}}$ Wait Time	t _{CSW}	—	250	—	ns	
Data Processing Time	t _{DOFF}	R ₁ = 8.2 kΩ±5%, C ₁ = 82 pF±5%	8	—	μs	
$\overline{\text{RESET}}$ Pulse Width	t _{WRES}	—	250	—	ns	
$\overline{\text{RESET}}$ Time	t _{RSON}	—	250	—	ns	
DA Wait Time	t _{RSOFF}	—	250	—	ns	
All Driver Output Slew Rate	t _R	C _i = 100 pF	t _R = 20 to 80%	—	2.0	μs
	t _F		t _F = 80 to 20%	—	2.0	μs

AC Characteristics-2(V_{DD}=3.3V±10%, V_{DISP}=42V, Ta=-40 to+85°C, unless otherwise specified)

Parameter	Symbol	Condition	Min.	Max.	Unit	
$\overline{\text{CP}}$ Frequency	f _C	—	—	2.0	MHz	
$\overline{\text{CP}}$ Pulse Width	t _{CW}	—	250	—	ns	
DA Setup Time	t _{DS}	—	250	—	ns	
DA Hold Time	t _{DH}	—	250	—	ns	
$\overline{\text{CS}}$ Setup Time	t _{CSS}	—	250	—	ns	
$\overline{\text{CS}}$ Hold Time	t _{CSH}	R ₁ = 6.8 kΩ±5%, C ₁ = 82 pF±5%	16	—	μs	
$\overline{\text{CS}}$ Wait Time	t _{CSW}	—	250	—	ns	
Data Processing Time	t _{DOFF}	R ₁ = 6.8 kΩ±5%, C ₁ = 82 pF±5%	8	—	μs	
$\overline{\text{RESET}}$ Pulse Width	t _{WRES}	—	250	—	ns	
$\overline{\text{RESET}}$ Execution Time	t _{RSON}	—	250	—	ns	
DA Wait Time	t _{RSOFF}	—	250	—	ns	
All Driver Output Slew Rate	t _R	C _i = 100 pF	t _R = 20 to 80%	—	2.0	μs
	t _F		t _F = 80 to 20%	—	2.0	μs

TIMING DIAGRAMS

1) Data Input Timing

Symbol	$V_{DD} = 3.3\text{ V} \pm 10\%$	$V_{DD} = 5.0\text{ V} \pm 10\%$
V_{IH}	$0.8 V_{DD}$	$0.7 V_{DD}$
V_{IL}	$0.2 V_{DD}$	$0.3 V_{DD}$

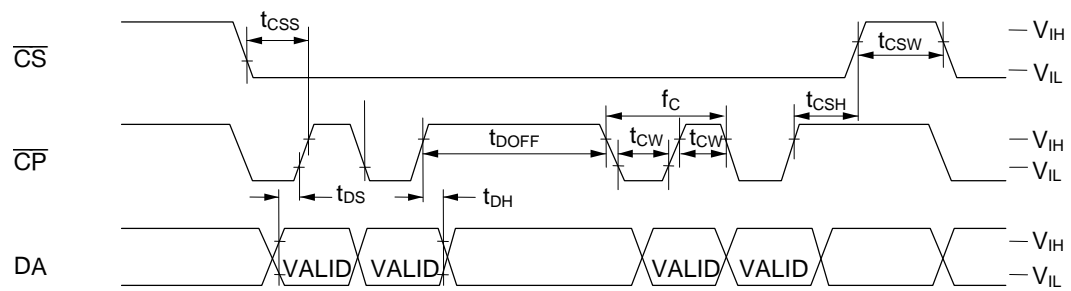

2) Data Input Timing

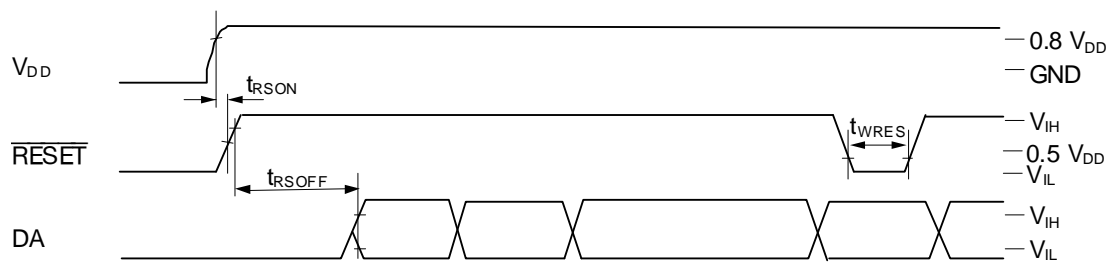

3) Output Timing



4) Digit Output Timing (16-Digit, 15/16-Duty)

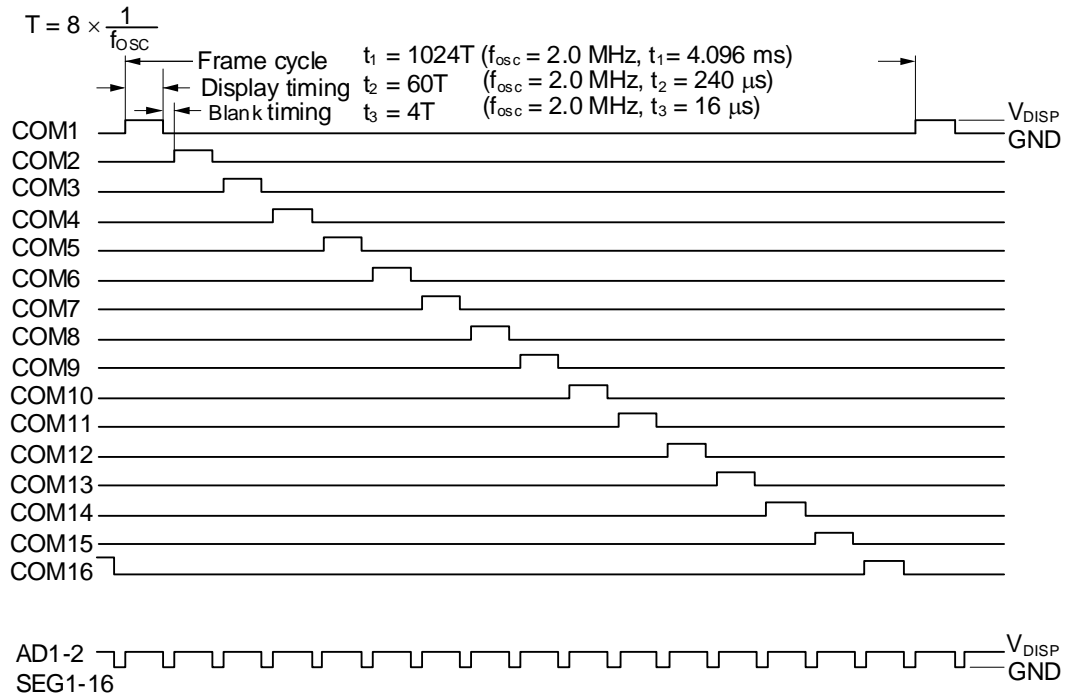

FUNCTIONAL DESCRIPTION

Command List

Command	First byte								Second byte								
	B0	B1	B2	B3	B4	B5	B6	B7	B0	B1	B2	B3	B4	B5	B6	B7	
1 DCRAM data write	X0	X1	X2	X3	1	0	0	0	C0	C1	C2	C3	C4	C5	C6	C7	
2 CGRAM data write	X0	X1	X2	X3	0	1	0	0	C0	C1	C2	C3	C4	C5	C6	C7	2nd byte
									C8	C9	C10	C11	C12	C13	C14	C15	3rd byte
3 ADRAM data write	X0	X1	X2	X3	1	1	0	0	C0	C1	*	*	*	*	*	*	
4 Display duty set	D0	D1	D2	D3	1	0	1	0									
5 Number of digits set	K0	K1	K2	K3	0	1	1	0	* : Don't care								
6 All display lights ON/OFF	L	H	*	*	1	1	1	0	Xn : Address setting for each RAM								
									Cn : Character code setting for each RAM								
Others (test mode)									Dn : Display duty setting								
									Kn : Setting of the number of display digits								
									H : All display lights ON setting								
									L : All display lights OFF setting								

When data is written to RAM (DCRAM, CGRAM, and ADRAM) continuously, addresses are internally incremented automatically. Therefore it is not necessary to specify the 1st byte to write RAM data for the 2nd and subsequent bytes.

Note: The test mode is used for inspection before shipment. It is not a user function.

Positional Relationship Between SEGn and ADn (one digit)

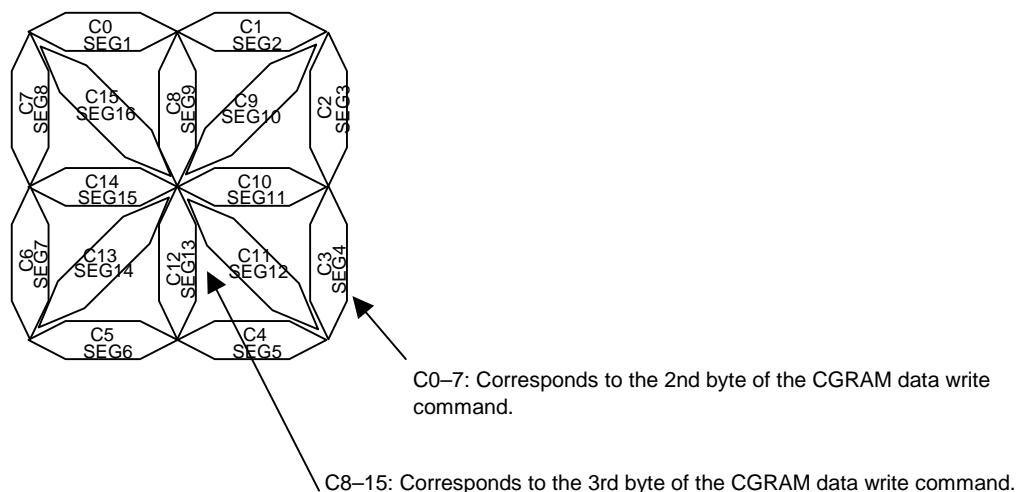

Data Transfer Method and Command Write Method

Display control command and data are written by an 8-bit serial transfer. Write timing is shown in the figure below.

Setting the \overline{CS} pin to “Low” level enables a data transfer.

Data is 8 bits and is sequentially input into the DA pin from LSB (LSB first).

As shown in the figure below, data is read by the shift register at the rising edge of the shift clock, which is input into the \overline{CP} pin. If 8-bit data is input, internal load signals are automatically generated and data is written to each register and RAM.

Therefore it is not necessary to input load signals from the outside.

Setting the \overline{CS} pin to “High” disables data transfer. Data input from the point when the \overline{CS} pin changes from “High” to “Low” is recognized in 8-bit units.

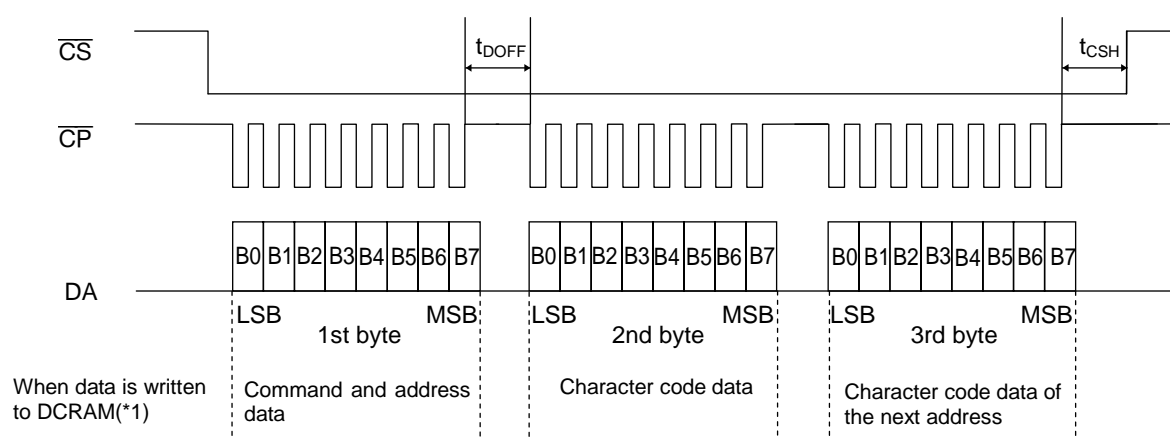

*1 When data is written to RAM (DCRAM, CGRAM, ADRAM) continuously, addresses are internally incremented automatically. Therefore it is not necessary to specify the 1st byte to write RAM data for the 2nd and subsequent bytes.

Reset Function

Reset is executed when the \overline{RESET} pin is set to “L”, (when turning power on, for example) and initializes all functions.

Initial status is as follows.

- Address of each RAMAddress 00H
- Data of each RAMAll contents are undefined.
- Number of display digits16 digits
- Brightness adjustment0/16
- All display lights ON or OFFOFF mode
- Segment output.....All segment outputs go “Low.”
- AD output.....All AD outputs go “Low.”

Be sure to execute the reset operation when turning power on and set again according to “Setting Flowchart” after reset.

Description of Commands and Functions

1. "DCRAM data write" command

(Specifies the address of DCRAM and writes the character code of CGROM and CGRAM.)

DCRAM (Data Control RAM) has a 4-bit address to store character codes of CGROM and CGRAM.

A character code specified by DCRAM is converted to an alphanumeric character pattern via CGROM or CGRAM.

The DCRAM can store 16 characters worth of character codes.

[Command format]

	LSB		MSB						
	B0	B1	B2	B3	B4	B5	B6	B7	
1st byte (1st)	X0	X1	X2	X3	1	0	0	0	: Setup and DCRAM address in the write mode of DCRAM data are specified. (Example: Specify DCRAM address 0H.)
	LSB		MSB						
	B0	B1	B2	B3	B4	B5	B6	B7	
2nd byte (2nd)	C0	C1	C2	C3	C4	C5	C6	C7	: Specify character code of CGROM and CGRAM. (It is written into DCRAM address 00H.)

To specify the character code of CGROM and CGRAM to the next address continuously, specify only character code as follows.

Since the address of DCRAM is automatically incremented, address specification is unnecessary.

	LSB		MSB						
	B0	B1	B2	B3	B4	B5	B6	B7	
2nd byte (3rd)	C0	C1	C2	C3	C4	C5	C6	C7	: Specify character code of CGROM and CGRAM. (It is written into DCRAM address 1H.)
	LSB		MSB						
	B0	B1	B2	B3	B4	B5	B6	B7	
2nd byte (4th)	C0	C1	C2	C3	C4	C5	C6	C7	: Specify character code of CGROM and CGRAM. (It is written into DCRAM address 2H.)
			⋮						
	LSB		MSB						
	B0	B1	B2	B3	B4	B5	B6	B7	
2nd byte (17th)	C0	C1	C2	C3	C4	C5	C6	C7	: Specify character code of CGROM and CGRAM. (It is written into DCRAM address FH.)
	LSB		MSB						
	B0	B1	B2	B3	B4	B5	B6	B7	
2nd byte (18th)	C0	C1	C2	C3	C4	C5	C6	C7	: Specify character code of CGROM and CGRAM. (It is rewritten into DCRAM address 0H.)

X0 (LSB) to X3 (MSB): DCRAM address (4 bits: 16 characters worth)

C0 (LSB) to C7 (MSB): Character code of CGROM and CGRAM (8 bits: 256 characters worth)

[Relationship between DCRAM addresses setup and COM positions]

HEX	X0	X1	X2	X3	COM position	HEX	X0	X1	X2	X3	COM position
0	0	0	0	0	COM1	8	0	0	0	1	COM9
1	1	0	0	0	COM2	9	1	0	0	1	COM10
2	0	1	0	0	COM3	A	0	1	0	1	COM11
3	1	1	0	0	COM4	B	1	1	0	1	COM12
4	0	0	1	0	COM5	C	0	0	1	1	COM13
5	1	0	1	0	COM6	D	1	0	1	1	COM14
6	0	1	1	0	COM7	E	0	1	1	1	COM15
7	1	1	1	0	COM8	F	1	1	1	1	COM16

[Positional relationship between CGRAM addresses setup and CGROM addresses]

HEX	X0	X1	X2	X3	CGROM address	HEX	X0	X1	X2	X3	CGROM address
0	0	0	0	0	RAM00	8	0	0	0	1	RAM08
1	1	0	0	0	RAM01	9	1	0	0	1	RAM09
2	0	1	0	0	RAM02	A	0	1	0	1	RAM0A
3	1	1	0	0	RAM03	B	1	1	0	1	RAM0B
4	0	0	1	0	RAM04	C	0	0	1	1	RAM0C
5	1	0	1	0	RAM05	D	1	0	1	1	RAM0D
6	0	1	1	0	RAM06	E	0	1	1	1	RAM0E
7	1	1	1	0	RAM07	F	1	1	1	1	RAM0F

Refer to the ROM Code Tables attached later in this document.

Positional Relationship Between CGROM and CGRAM outputs

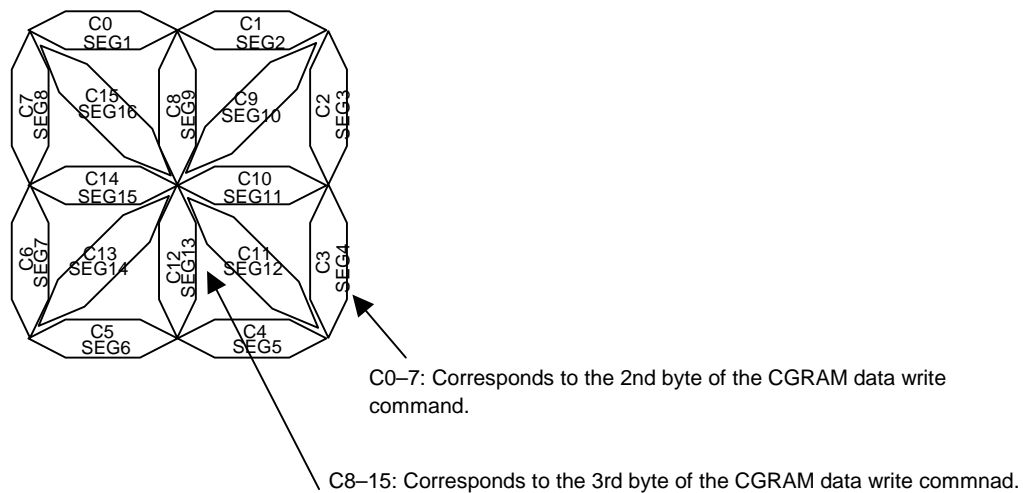

*On CGROM

A CGROM (Character Generator ROM) has an 8-bit address to generate alphanumeric type matrix character patterns.

It has a capacity of 240 x 16 bits and can store 240 types of character patterns.

3. “ADRAM data write” command

(Specifies the address of ADRAM and writes symbol data)

ADRAM (Additional Data RAM) has a 2-bit address to store symbol data.
 Symbol data specified by ADRAM is directly output without CGROM and CGRAM.
 (The ADRAM can store two types of symbol patterns for each digit.)
 The terminal to which the contents of ADRAM are output can be used as a cursor.

[Command format]

	LSB		MSB						
	B0	B1	B2	B3	B4	B5	B6	B7	
1st byte (1st)	X0	X1	X2	X3	1	1	0	0	: Setup and DCRAM address in the write-in mode of DCRAM data are specified. (Example: Specify ADRAM address 0H.)
	LSB		MSB						
	B0	B1	B2	B3	B4	B5	B6	B7	
2nd byte (2nd)	C0	C1	*	*	*	*	*	*	: Specify symbol data. (Example: Specify ADRAM address 0H.)

To specify symbol data continuously to the next address, specify only symbol data as follows.
 Since the address of ADRAM is automatically incremented, address specification is unnecessary.

	LSB		MSB						
	B0	B1	B2	B3	B4	B5	B6	B7	
2nd byte (3rd)	C0	C1	*	*	*	*	*	*	: Specify symbol data. (It is written into ADRAM address 1H.)
	LSB		MSB						
	B0	B1	B2	B3	B4	B5	B6	B7	
2nd byte (4th)	C0	C1	*	*	*	*	*	*	: Specify symbol data. (It is written into ADRAM address 2H.)
			⋮						
	LSB		MSB						
	B0	B1	B2	B3	B4	B5	B6	B7	
2nd byte (17th)	C0	C1	*	*	*	*	*	*	: Specify symbol data. (It is written into ADRAM address FH.)
	LSB		MSB						
	B0	B1	B2	B3	B4	B5	B6	B7	
2nd byte (18th)	C0	C1	*	*	*	*	*	*	: Specify symbol data. (It is rewritten into ADRAM address 0H.)

X0 (LSB) to X3 (MSB) : ADRAM address (4 bits: 16 characters worth)

C0 (LSB) to C1 (MSB) : Symbol data (2 bits: 2 symbols per digit)

* : Don't care

[Relationship between ADRAM addresses setup and COM positions]

HEX	X0	X1	X2	X3	COM positions	HEX	X0	X1	X2	X3	COM positions
0	0	0	0	0	COM1	8	0	0	0	1	COM9
1	1	0	0	0	COM2	9	1	0	0	1	COM10
2	0	1	0	0	COM3	A	0	1	0	1	COM11
3	1	1	0	0	COM4	B	1	1	0	1	COM12
4	0	0	1	0	COM5	C	0	0	1	1	COM13
5	1	0	1	0	COM6	D	1	0	1	1	COM14
6	0	1	1	0	COM7	E	0	1	1	1	COM15
7	1	1	1	0	COM8	F	1	1	1	1	COM16

4. "Display duty set" command

(Writes display duty value into the duty cycle register.)

For display duty, brightness can be adjusted in 16 stages using 4-bit data.

When power is turned on or when the $\overline{\text{RESET}}$ signal is input, the duty cycle register value is "0". Always execute this command before turning the display on, then set a desired duty value.

[Command format]

	LSB	B0	B1	B2	B3	B4	B5	B6	B7	MSB	
1st byte	D0	D1	D2	D3	1	0	1	0	: setup and duty value in display duty specification mode are specified.		

D0 (LSB) to D3 (MSB) : Display duty data (4 bits: 16 stages worth)

[Relation between setup data and controlled COM duty]

HEX	D0	D1	D2	D3	COM duty	HEX	D0	D1	D2	D3	COM duty
0	0	0	0	0	0/16	8	0	0	0	1	8/16
1	1	0	0	0	1/16	9	1	0	0	1	9/16
2	0	1	0	0	2/16	A	0	1	0	1	10/16
3	1	1	0	0	3/16	B	1	1	0	1	11/16
4	0	0	1	0	4/16	C	0	0	1	1	12/16
5	1	0	1	0	5/16	D	1	0	1	1	13/16
6	0	1	1	0	6/16	E	0	1	1	1	14/16
7	1	1	1	0	7/16	F	1	1	1	1	15/16

* The state when power is turned on or when the $\overline{\text{RESET}}$ signal is input.

5. "Number of display digits set" command

(Writes the number of display digits into the number-of-display-digits register.)

For the number of display digits, 1 to 16 digits can be specified using 4-bit data.

When power is turned on or when a $\overline{\text{RESET}}$ signal is input, the number-of-display-digits register value is "0". Always execute this command before turning the display on, then set a desired value.

[Command format]

	LSB	B0	B1	B2	B3	B4	B5	B6	B7	MSB	
1st byte	K0	K1	K2	K3	0	1	1	0	: Setup in display digits specification mode and digits value is specified.		

K0 (LSB) to K3 (MSB) : Data of the number of display digits (4 bits: 16 digits worth)

[Relation between data to be set and the number of digits of COM to be controlled]

	HEX	K0	K1	K2	K3	No. of digits of COM	HEX	K0	K1	K2	K3	No. of digits of COM
→	0	0	0	0	0	COM1-16	8	0	0	0	1	COM1-8
	1	1	0	0	0	COM1	9	1	0	0	1	COM1-9
	2	0	1	0	0	COM1-2	A	0	1	0	1	COM1-10
	3	1	1	0	0	COM1-3	B	1	1	0	1	COM1-11
	4	0	0	1	0	COM1-4	C	0	0	1	1	COM1-12
	5	1	0	1	0	COM1-5	D	1	0	1	1	COM1-13
	6	0	1	1	0	COM1-6	E	0	1	1	1	COM1-14
	7	1	1	1	0	COM1-7	F	1	1	1	1	COM1-15

* The state when power is turned on or when the $\overline{\text{RESET}}$ signal is input.

6. “All display lights ON” and “All display lights OFF” commands
(Turns the entire display ON and OFF, respectively.)

All display lights ON is used primarily for display testing.

All display lights OFF is primarily used for display blink and to prevent false display upon power-on.

[Command format]

	LSB							MSB	
	B0	B1	B2	B3	B4	B5	B6	B7	
1st byte	L	H	*	*	1	1	1	0	: Select all display lights ON or OFF and specify their operation.
	L: All display lights OFF H: All display lights ON *: Don't Care								

[Data to be setup and display state of SEG and AD]

L	H	Display state of SEG and AD	
0	0	Normal display	
1	0	Sets all outputs to Low	* The state when power is turned on or when $\overline{\text{RESET}}$ signal is input
0	1	Sets all outputs to High	
1	1	Sets all outputs to High	* Priority is given to the All display lights ON command.

Setting Flowchart
(Power applying included)

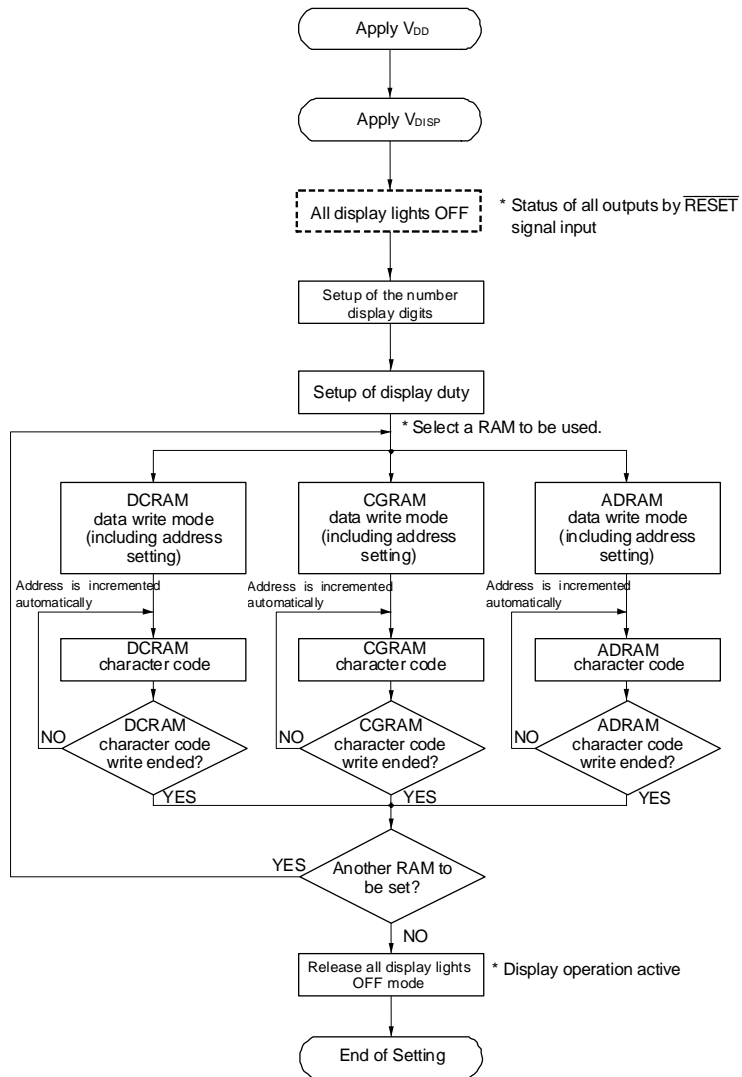

Power-off Flowchart

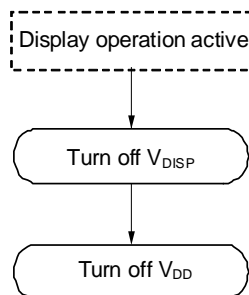

POWER-ON/OFF TIMING

To prevent the IC from malfunctioning, turn on the logic power supply first, and then turn on the driver power supply when applying power. Also, for power-off, turn off the driver power supply first, then turn off the logic power supply.

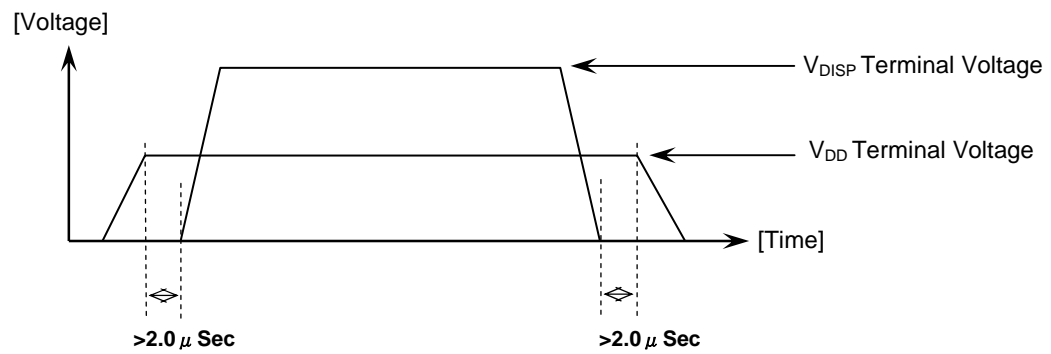

APPLICATION CIRCUIT

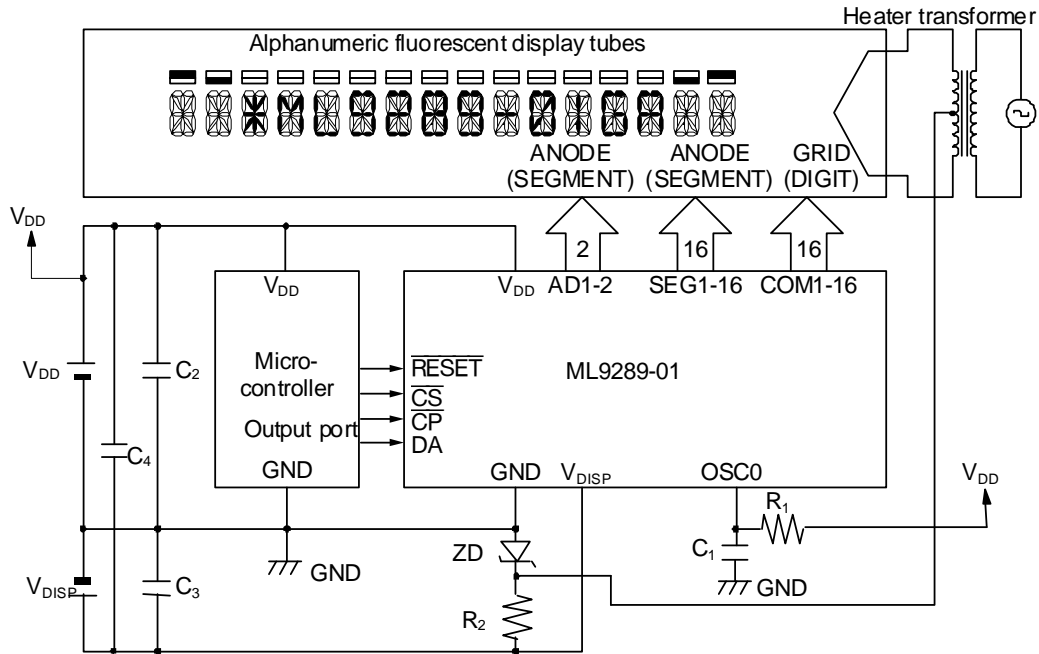

Notes:

1. The V_{DD} voltage depends on the power supply voltage of the microcontroller used. Adjust the value of the constants R_1 and C_1 to the power supply voltage used.
2. The V_{DISP} voltage depends on the vacuum fluorescent display tube used. Adjust the value of the constants R_2 and ZD to the voltage used.

Reference data

Shown below is a chart showing the V_{DISP} voltage vs. output current of each driver. Care must be taken that the entire power consumption will not exceed the power dissipation.

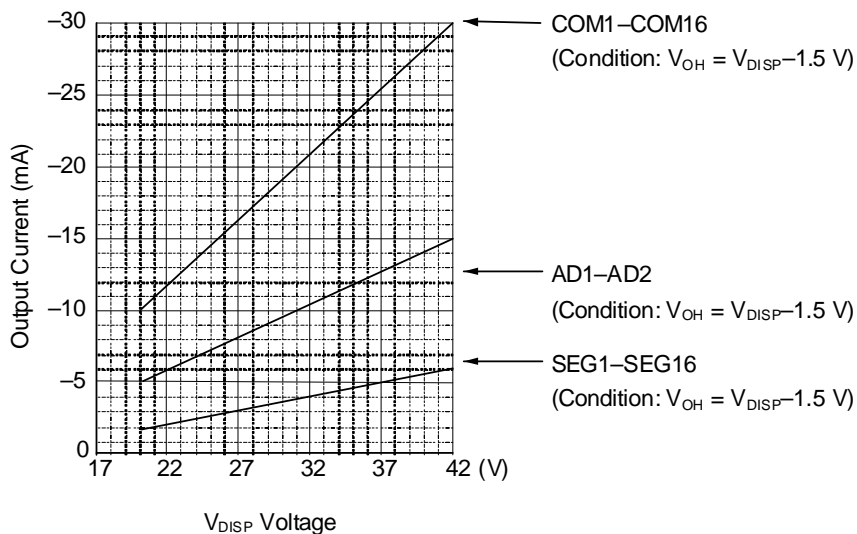

V_{DISP} Voltage vs. Output Current of Each Driver

ML9289-01 ROM CODE

*ROM CODE is the character set for SEG1 to SEG16.

*00000000b(00h) to 00001111b(0Fh) are the CGRAM addresses

MSB LSB		0000	0001	0010	0011	0100	0101	0110	0111	1000	1001	1010	1011	1100	1101	1110	1111
0000	RAM0																
0001	RAM1																
0010	RAM2																
0011	RAM3																
0100	RAM4																
0101	RAM5																
0110	RAM6																
0111	RAM7																
1000	RAM8																
1001	RAM9																
1010	RAMA																
1011	RAMB																
1100	RAMC																
1101	RAMD																
1110	RAM E																
1111	RAMF																

PACKAGE DIMENSIONS

(Unit: mm)

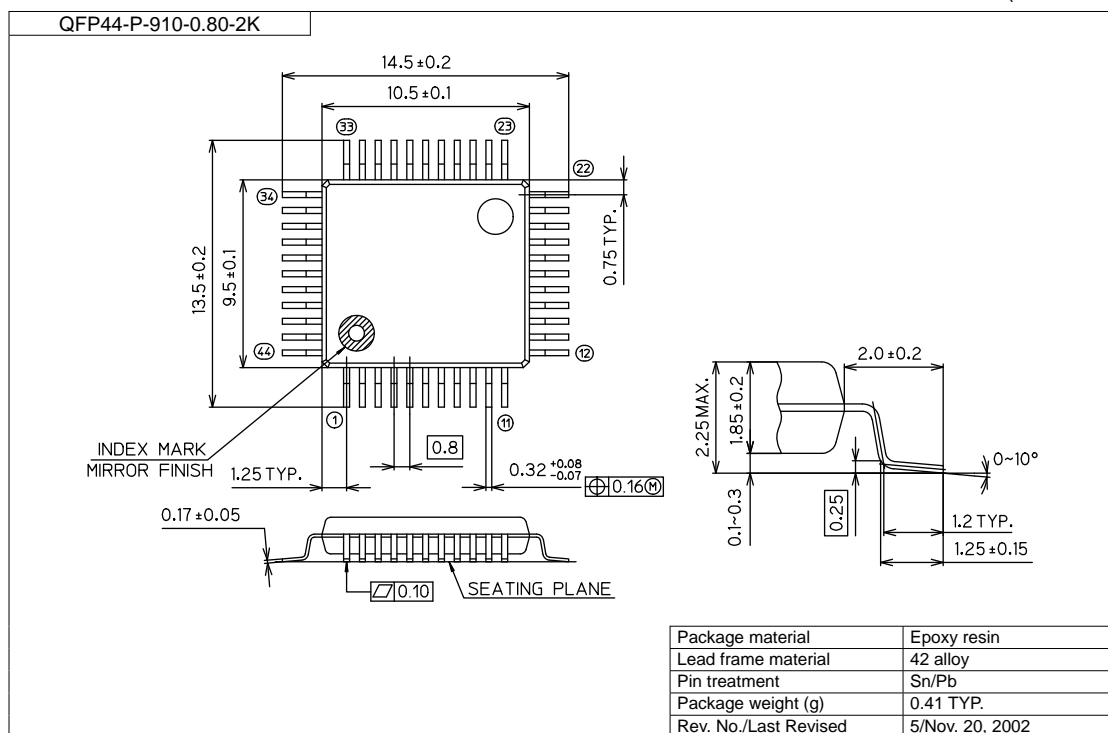

Notes for Mounting the Surface Mount Type Package

The surface mount type packages are very susceptible to heat in reflow mounting and humidity absorbed in storage. Therefore, before you perform reflow mounting, contact ROHM's SEMICONDUCTOR's responsible sales person for the product name, package name, pin number, package code and desired mounting conditions (reflow method, temperature and times).

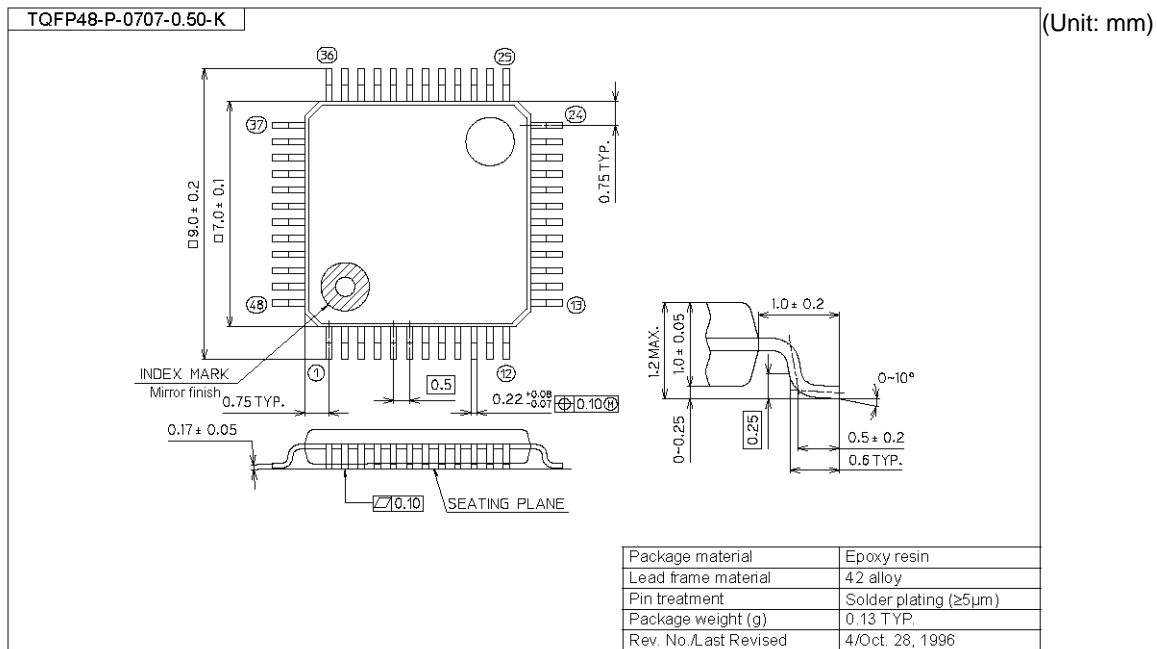

Notes for Mounting the Surface Mount Type Package

The surface mount type packages are very susceptible to heat in reflow mounting and humidity absorbed in storage. Therefore, before you perform reflow mounting, contact ROHM's responsible sales person for the product name, package name, pin number, package code and desired mounting conditions (reflow method, temperature and times).

REVISION HISTORY

Document No.	Date	Page		Description
		Previous Edition	Current Edition	
FEDL9289-01	May 15, 2009	—	—	Final edition 1

NOTICE

No copying or reproduction of this document, in part or in whole, is permitted without the consent of LAPIS Semiconductor Co., Ltd.

The content specified herein is subject to change for improvement without notice.

The content specified herein is for the purpose of introducing LAPIS Semiconductor's products (hereinafter "Products"). If you wish to use any such Product, please be sure to refer to the specifications, which can be obtained from LAPIS Semiconductor upon request.

Examples of application circuits, circuit constants and any other information contained herein illustrate the standard usage and operations of the Products. The peripheral conditions must be taken into account when designing circuits for mass production.

Great care was taken in ensuring the accuracy of the information specified in this document. However, should you incur any damage arising from any inaccuracy or misprint of such information, LAPIS Semiconductor shall bear no responsibility for such damage.

The technical information specified herein is intended only to show the typical functions of and examples of application circuits for the Products. LAPIS Semiconductor does not grant you, explicitly or implicitly, any license to use or exercise intellectual property or other rights held by LAPIS Semiconductor and other parties. LAPIS Semiconductor shall bear no responsibility whatsoever for any dispute arising from the use of such technical information.

The Products specified in this document are intended to be used with general-use electronic equipment or devices (such as audio visual equipment, office-automation equipment, communication devices, electronic appliances and amusement devices).

The Products specified in this document are not designed to be radiation tolerant.

While LAPIS Semiconductor always makes efforts to enhance the quality and reliability of its Products, a Product may fail or malfunction for a variety of reasons.

Please be sure to implement in your equipment using the Products safety measures to guard against the possibility of physical injury, fire or any other damage caused in the event of the failure of any Product, such as derating, redundancy, fire control and fail-safe designs. LAPIS Semiconductor shall bear no responsibility whatsoever for your use of any Product outside of the prescribed scope or not in accordance with the instruction manual.

The Products are not designed or manufactured to be used with any equipment, device or system which requires an extremely high level of reliability the failure or malfunction of which may result in a direct threat to human life or create a risk of human injury (such as a medical instrument, transportation equipment, aerospace machinery, nuclear-reactor controller, fuel-controller or other safety device). LAPIS Semiconductor shall bear no responsibility in any way for use of any of the Products for the above special purposes. If a Product is intended to be used for any such special purpose, please contact a ROHM sales representative before purchasing.

If you intend to export or ship overseas any Product or technology specified herein that may be controlled under the Foreign Exchange and the Foreign Trade Law, you will be required to obtain a license or permit under the Law.