

Product List .....	3
Description .....	3
Ordering Information .....	3
Features .....	3
Pin Configuration .....	3
Block Diagram.....	6
Special Function Register (SFR) .....	8
Function Description .....	10
1. General Features .....	10
1.1 Embedded Flash .....	10
1.2 IO Pads .....	10
1.3 System Control Register (SCONF) .....	10
2. Instruction Set .....	11
3. Memory Structure .....	15
3.1 Program Memory .....	15
3.2 Data Memory.....	16
3.3 Data memory - lower 128 byte (00h to 7Fh) .....	16
3.4 Data memory - higher 128 byte (80h to FFh).....	16
4. CPU Engine .....	17
4.1 Accumulator .....	17
4.2 B Register .....	17
4.3 Program Status Word.....	18
4.4 Stack Pointer .....	18
4.5 Data Pointer .....	18
5. GPIO .....	19
6. Timer 0 and Timer 1.....	20
6.1 Timer/counter mode control register (TMOD) .....	20
6.2 Timer/counter control register (TCON) .....	21
6.3 Mode 0 (13-bit Counter/Timer).....	21
6.4 Mode 1 (16-bit Counter/Timer).....	22
6.5 Mode 2 (8-bit auto-reload Counter/Timer) .....	22
6.6 Mode 3 (Timer 0 acts as two independent 8 bit Timers / Counters) .....	22
7. Timer 2.....	24
7.1 Capture mode .....	25
7.2 Auto-reload (Up or Down Counter) .....	26
7.3 Programmable clock out .....	27
8. Serial interface – UART .....	29
8.1 Serial interface .....	29
8.1.1 Mode 0.....	30
8.1.2 Mode 1.....	30
8.1.3 Mode 2.....	31
8.1.4 Mode 3.....	31
8.2 Multiprocessor Communication of Serial Interface .....	31
8.3 Baud Rate Generator .....	32
8.3.1 Serial interface Mode 0 .....	32
8.3.2 Serial interface Mode 2 .....	32
8.3.3 Serial interface Mode 1 and 3 .....	32
9. Interrupt.....	33
10. Watch Dog Timer .....	35
11. Power Management Unit .....	37
11.1 Idle mode .....	37
11.2 Power Down mode.....	37
12. In-System Programming (Internal ISP).....	38
12.1 ISP service program.....	38
12.2 Lock Bit (N) .....	38
12.3 Program the ISP Service Program.....	39

Specifications subject to change without notice contact your sales representatives for the most recent information.



---

12.4	Initiate ISP Service Program .....	39
12.5	ISP register – ISPFAH, ISPFAL, ISPC and ISPD .....	39
	Operating Conditions .....	42
	DC Characteristics .....	42

## Product List

SM5953W40PP,  
SM5953W44JP,  
SM5953W44QP,

## Description

The SM5953 series product is an 8 - bit single chip micro controller with 15KB flash & 256 bytes SRAM embedded. It has In-System Programming (ISP) function and is a derivative of the 8052 micro controller family.

SM5953 is a versatile and cost effective controller for those applications which demand up to 32 I/O pins, or applications which need up to 15K byte flash memory either for program or for data or mixed.

To program the on-chip flash memory, a commercial writer is available to do it in parallel programming method. The on-chip flash memory can be programmed in either parallel or serial interface with its ISP feature.

## Ordering Information

SM5953ihhkL YWW

i: process identifier { W = 2.4V ~ 5.5V }

hh: pin count

k: package type postfix {as table below }

L:PB Free identifier

{No text is Non-PB free, "P" is PB free}

Y: year

WW: week

Postfix	Package
P	PDIP
J	PLCC
Q	PQFP

## Features

- Main Flash ROM 15KB
- Working voltage 2.4V~5.5V runs up to 40MHz
- General 8052 family compatible with 12 clocks in one machine cycle
- 6 clocks in one machine cycle is also supported
- 256 bytes SRAM as standard 8052.
- 16-bit Data Pointers (DPTR).
- One serial peripheral interfaces in full duplex mode (UART).
  - Synchronous mode, fixed baud rate.
  - 8-bit UART mode, variable baud rate.
  - 9-bit UART mode, fixed baud rate.
  - 9-bit UART mode, variable baud rate.
- Three 16-bit Timer/Counters. (Timer 0, 1, 2).
- One watch dog timer (WDT).
- ISP/IAP functions.
- ISP service program space configurable in N (N=0 to 8).
- EEPROM function.
- Six interrupt sources with two priority levels.
- Four 8-bit I/O ports
- IO PAD ESD over 4KV
- Enhance user code protection.
- Power management unit for IDLE and power down modes.

## Pin Configuration

### 40 Pin PDIP

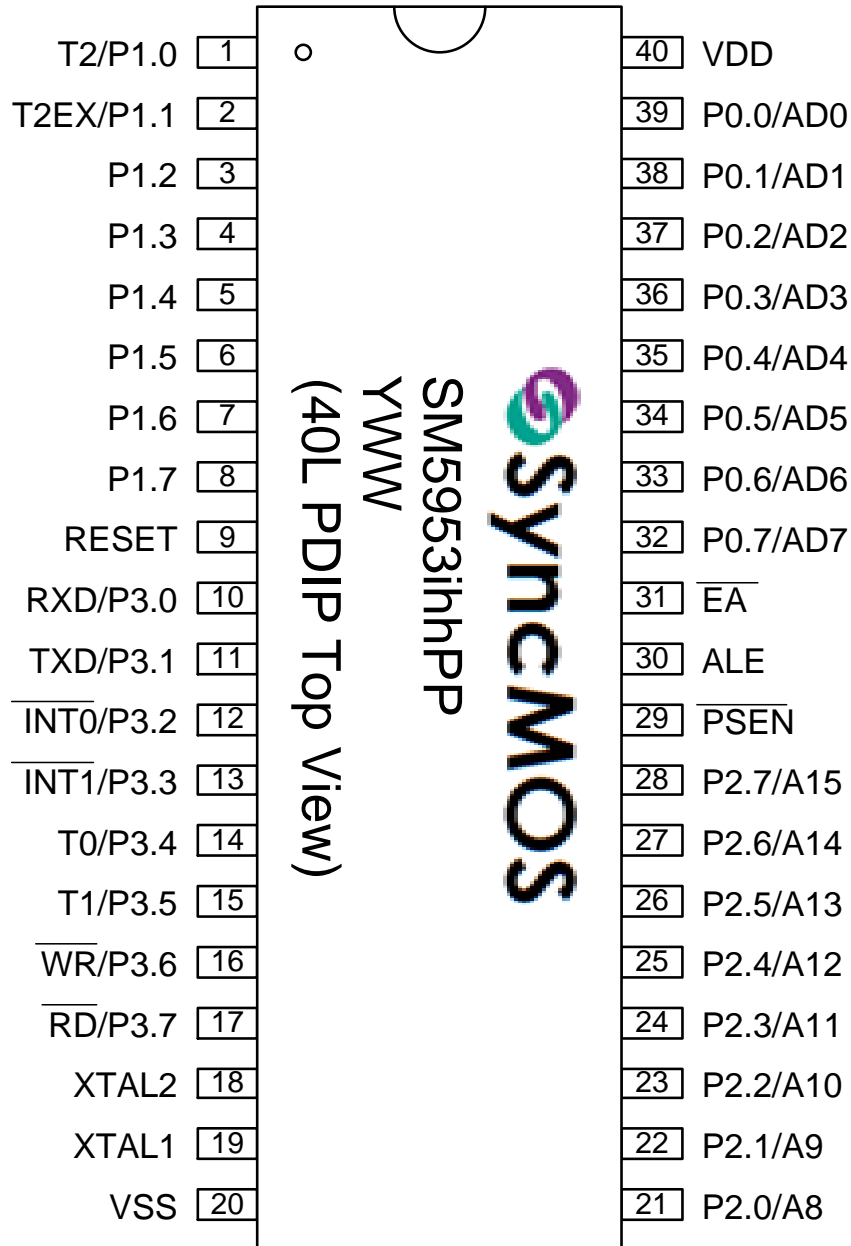



**44 Pin PLCC**

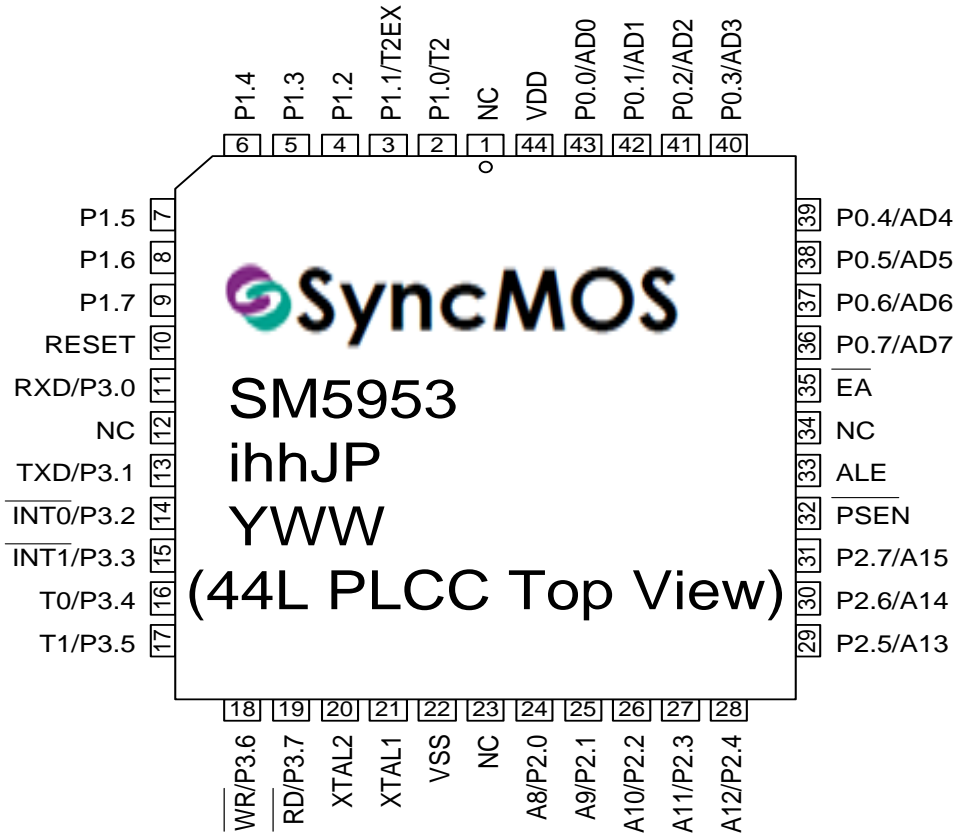



**44 Pin PQFP**

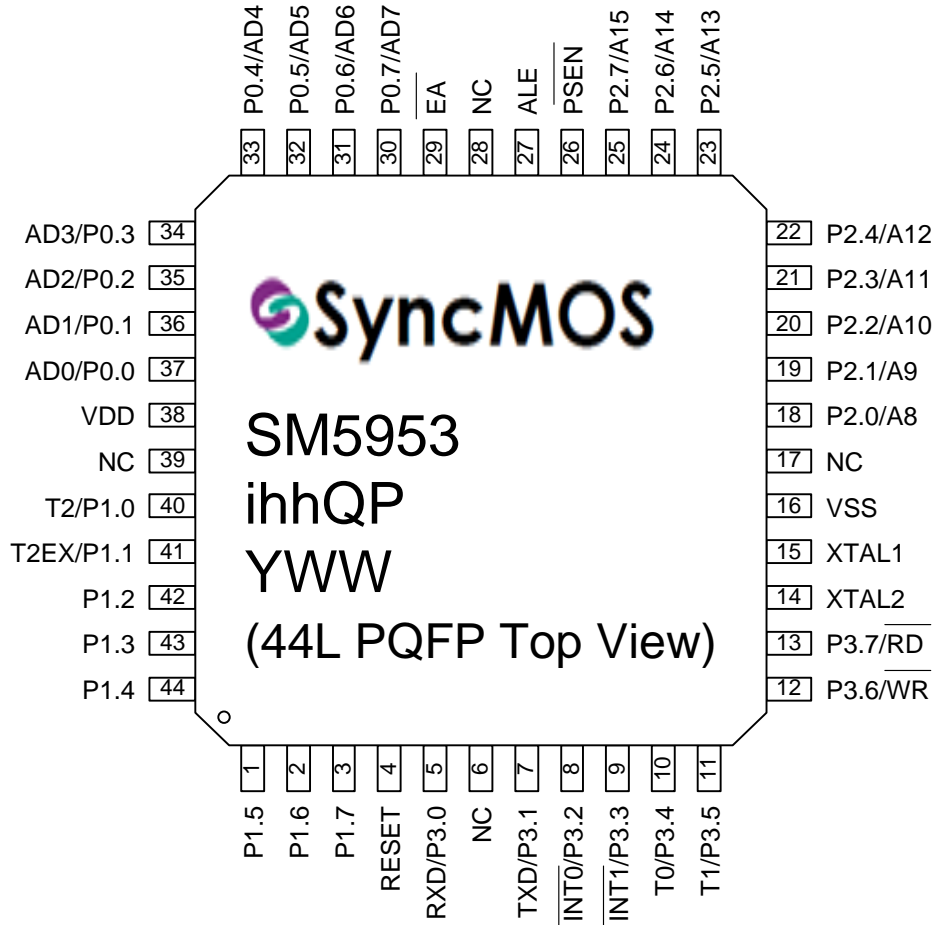

## Block Diagram

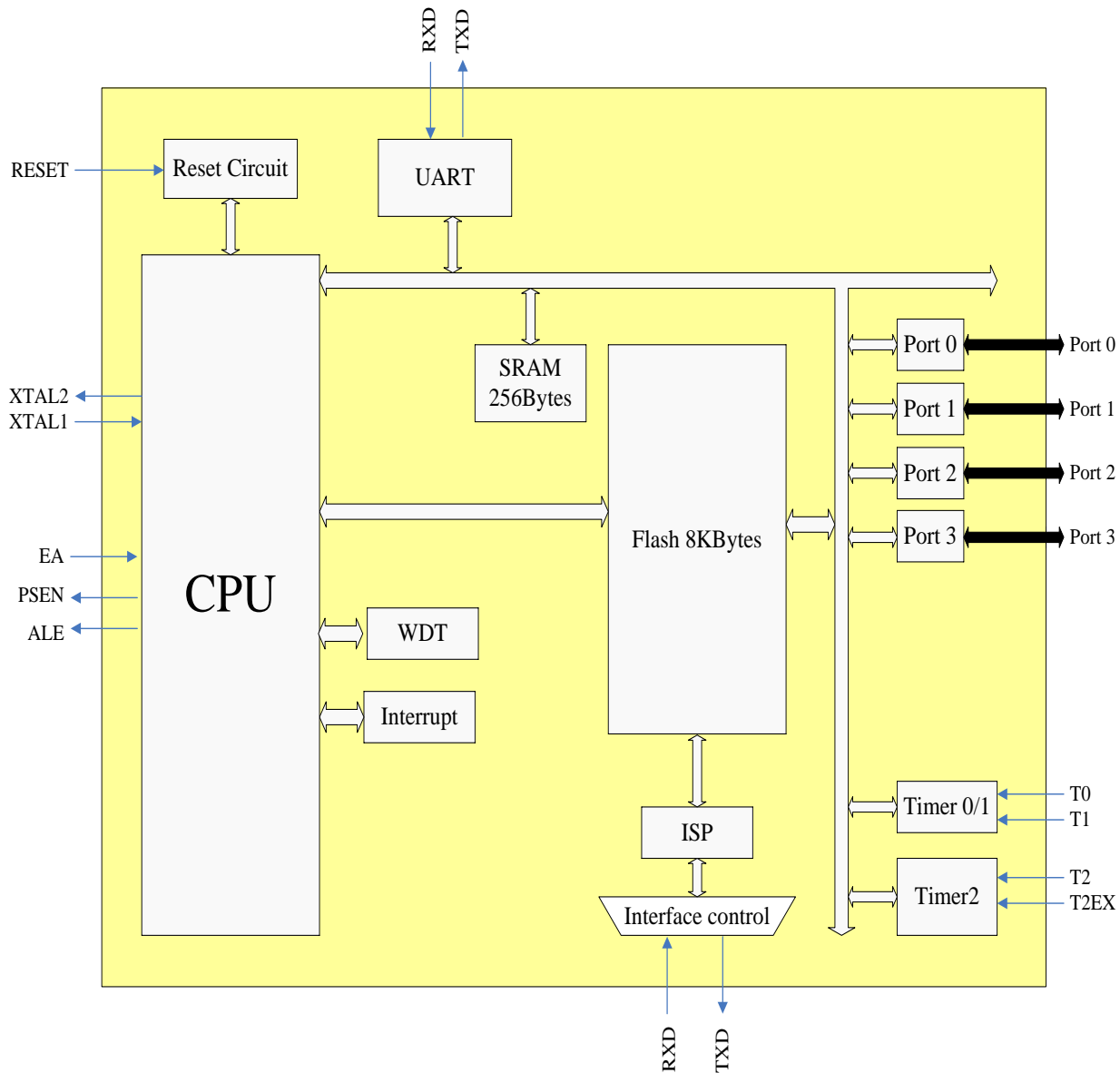

## Pin Description

40L PDIP	40L PLCC	40L PQFP	Symbol	I/O	Description
1	2	40	P1.0/T2	I/O	Bit 0 of port 1 & Timer 2 external input clock
2	3	41	P1.1/T2EX	I/O	Bit 1 of port 1 & Timer 2 capture trigger
3	4	42	P1.2	I/O	Bit 2 of port 1
4	5	43	P1.3	I/O	Bit 3 of port 1
5	6	44	P1.4	I/O	Bit 4 of port 1
6	7	1	P1.5	I/O	Bit 5 of port 1
7	8	2	P1.6	I/O	Bit 6 of port 1
8	9	3	P1.7	I/O	Bit 7 of port 1
9	10	4	RESET	I	Reset pin
10	11	5	P3.0/RXD	I/O	Bit 0 of port 3 & Serial interface channel receive data
11	13	7	P3.1/TXD	I/O	Bit 1 of port 3 & Serial interface channel Transmit data
12	14	8	P3.2/INT0	I/O	Bit 2 of port 3 & Interrupt 0
13	15	9	P3.3/INT1	I/O	Bit 3 of port 3 & Interrupt 1
14	16	10	P3.4/T0	I/O	Bit 4 of port 3 & Timer 0 external input
15	17	11	P3.5/T1	I/O	Bit 5 of port 3 & Timer 1 external input
16	18	12	P3.6/WR	I/O	Bit 6 of port 3 & external memory write
17	19	13	P3.7/RD	I/O	Bit 7 of port 3 & external memory read
18	20	14	XTAL2	I/O	Crystal output
19	21	15	XTAL1	I/O	Crystal input
20	22	16	VSS	I	Ground
21	24	18	P2.0/A8	I/O	Bit 0 of port 2 & bit 8 of external memory address
22	25	19	P2.1/A9	I/O	Bit 1 of port 2 & bit 9 of external memory address
23	26	20	P2.2/A10	I/O	Bit 2 of port 2 & bit 10 of external memory address
24	27	21	P2.3/A11	I/O	Bit 3 of port 2 & bit 11 of external memory address
25	28	22	P2.4/A12	I/O	Bit 4 of port 2 & bit 12 of external memory address
26	29	23	P2.5/A13	I/O	Bit 5 of port 2 & bit 13 of external memory address
27	30	24	P2.6/A14	I/O	Bit 6 of port 2 & bit 14 of external memory address
28	31	25	P2.7/A15	I/O	Bit 7 of port 2 & bit 15 of external memory address
29	32	26	PSEN	O	program storage enable
30	33	27	ALE	O	address latch enable
31	35	29	EA	I	external access
32	36	30	P0.7/AD7	I/O	Bit 7 of port 0 & data/address bit 7 of external memory
33	37	31	P0.6/AD6	I/O	Bit 6 of port 0 & data/address bit 6 of external memory
34	38	32	P0.5/AD5	I/O	Bit 5 of port 0 & data/address bit 5 of external memory
35	39	33	P0.4/AD4	I/O	Bit 4 of port 0 & data/address bit 4 of external memory
36	40	34	P0.3/AD3	I/O	Bit 3 of port 0 & data/address bit 3 of external memory
37	41	35	P0.2/AD2	I/O	Bit 2 of port 0 & data/address bit 2 of external memory
38	42	36	P0.1/AD1	I/O	Bit 1 of port 0 & data/address bit 1 of external memory
39	43	37	P0.0/AD0	I/O	Bit 0 of port 0 & data/address bit 0 of external memory
40	44	38	VDD	I	Power supply



## Special Function Register (SFR)

A map of the Special Function Registers is shown as below:

Hex\Bin	X000	X001	X010	X011	X100	X101	X110	X111	Bin/Hex
F8									FF
F0	B				ISPF AH	ISPF AL	ISPF D	ISPC	F7
E8									EF
E0	ACC								E7
D8									DF
D0	PSW								D7
C8	T2CON	T2MOD	RCAP2L	RCAP2H	TL2	TH2			CF
C0									C7
B8	IP							SCONF	BF
B0	P3								B7
A8	IE								AF
A0	P2								A7
98	SCON	SBUF						WDTC	9F
90	P1								97
88	TCON	TMOD	TL0	TL1	TH0	TH1			8F
80	P0	SP	DPL	DPH				PCON	87
Hex\Bin	X000	X001	X010	X011	X100	X101	X110	X111	Bin/Hex

**Note: Special Function Registers reset values and description for SM5953.**

	Register	Location	Reset value	Description
1	P0	80H	FFH	Port 0
2	SP	81H	07H	Stack Pointer
3	DPL	82H	00H	Data Pointer 0 low byte
4	DPH	83H	00H	Data Pointer 0 high byte
5	PCON	87H	00H	Power Control
6	TCON	88H	00H	Timer/Counter Control
7	TMOD	89H	00H	Timer Mode Control
8	TL0	8AH	00H	Timer 0, low byte
9	TL1	8BH	00H	Timer 1, low byte
10	TH0	8CH	00H	Timer 0, high byte
11	TH1	8DH	00H	Timer 1, high byte
12	P1	90H	FFH	Port 1
13	SCON	98H	00H	Serial Port 0, Control Register
14	SBUF	99H	00H	Serial Port 0, Data Buffer
16	P2	A0H	FFH	Port 2
17	IE	A8H	00H	Interrupt Enable
18	P3	B0H	FFH	Port 3
19	IP	B8H	00H	Interrupt Priority
20	SCONF	BFH	02H	System Control Register
21	T2CON	C8H	00H	Timer 2 Control
22	T2MOD	C9H	00H	Timer 2 Mode
23	RCAP2L	CAH	00H	Timer2 Capture Low
24	RCAP2H	CBH	00H	Timer2 Capture High
25	TL2	CCH	00H	Timer 2, low byte
26	TH2	CDH	00H	Timer 2, high byte
27	PSW	D0H	00H	Program Status Word
28	ACC	E0H	00H	Accumulator
29	B	F0H	00H	B Register
30	ISPFAH	F4H	00H	ISP Flash Address-High Register
31	ISPFAL	F5H	00H	ISP Flash Address-Low Register
32	ISPFD	F6H	00H	ISP Flash Data Register
33	ISPC	F7H	00H	ISP control Register

## Function Description

### 1. General Features

SM5953 is an 8-bit micro-controller. All of its functions and the detailed meanings of SFR will be given in the following sections.

#### 1.1 Embedded Flash

The program can be loaded into the embedded 15KB Flash memory via its writer or In-System Programming (ISP). The high-quality Flash suitable for re-programming and data recording as EEPROM.

#### 1.2 IO Pads

The SM5953 has Five I/O ports: Port 0, Port 1, Port 2, Port 3. Port 0~Port 3 are 8-bit ports. These are: quasi-bidirectional (standard 8051 port outputs) with Port 1~3, and open drain with Port 0.

All the pads are with slew rate to reduce EMI. The IO pads can withstand ESD in human body mode guaranteeing the SM5953's quality in high electro-static environments.

#### 1.3 System Control Register (SCONF)

Mnemonic: SCONF							Address: BFh	
7	6	5	4	3	2	1	0	Reset
WDR	-	-	-	-	ISPE	-	ALEI	00H

WDR Watch Dog Timer Reset.

When system reset by Watch Dog Timer overflow, WDR will be set to 1.

User should check WDR bit whenever un-predicted reset happened.

ISPE ISP function enable bit.

When Enable the ISP function, ISPE will be set to 1.

ALEI ALE output inhibit bit.

When default, It can inhibit the clock signal in (Fosc/6) Hz output to the ALE pin.

When set to 1, the ALE pin output will stop to reduce EMI.

## 2. Instruction Set

All SM5953 instructions are binary code compatible and perform the same functions as they do with the industry standard 8051. The following tables give a summary of the instruction set cycles of the SM5953 Microcontroller core. As given in Table

Table 2-1: Arithmetic operations

Mnemonic	Description	Code	Bytes	Cycles
ADD A,Rn	Add register to accumulator	28-2F	1	1
ADD A,direct	Add direct byte to accumulator	25	2	1
ADD A,@Ri	Add indirect RAM to accumulator	26-27	1	1
ADD A,#data	Add immediate data to accumulator	24	2	1
ADDC A,Rn	Add register to accumulator with carry flag	38-3F	1	1
ADDC A,direct	Add direct byte to A with carry flag	35	2	1
ADDC A,@Ri	Add indirect RAM to A with carry flag	36-37	1	1
ADDC A,#data	Add immediate data to A with carry flag	34	2	1
SUBB A,Rn	Subtract register from A with borrow	98-9F	1	1
SUBB A,direct	Subtract direct byte from A with borrow	95	2	1
SUBB A,@Ri	Subtract indirect RAM from A with borrow	96-97	1	1
SUBB A,#data	Subtract immediate data from A with borrow	94	2	1
INC A	Increment accumulator	04	1	1
INC Rn	Increment register	08-0F	1	1
INC direct	Increment direct byte	05	2	1
INC @Ri	Increment indirect RAM	06-07	1	1
INC DPTR	Increment data pointer	A3	1	2
DEC A	Decrement accumulator	14	1	1
DEC Rn	Decrement register	18-1F	1	1
DEC direct	Decrement direct byte	15	2	1
DEC @Ri	Decrement indirect RAM	16-17	1	1
MUL AB	Multiply A and B	A4	1	4
DIV	Divide A by B	84	1	4
DA A	Decimal adjust accumulator	D4	1	1



Table 2-2: Logic operations

<b>Mnemonic</b>	<b>Description</b>	<b>Code</b>	<b>Bytes</b>	<b>Cycles</b>
ANL A,Rn	AND register to accumulator	58-5F	1	1
ANL A,direct	AND direct byte to accumulator	55	2	1
ANL A,@Ri	AND indirect RAM to accumulator	56-57	1	1
ANL A,#data	AND immediate data to accumulator	54	2	1
ANL direct,A	AND accumulator to direct byte	52	2	1
ANL direct,#data	AND immediate data to direct byte	53	3	2
ORL A,Rn	OR register to accumulator	48-4F	1	1
ORL A,direct	OR direct byte to accumulator	45	2	1
ORL A,@Ri	OR indirect RAM to accumulator	46-47	1	1
ORL A,#data	OR immediate data to accumulator	44	2	1
ORL direct,A	OR accumulator to direct byte	42	2	1
ORL direct,#data	OR immediate data to direct byte	43	3	2
XRL A,Rn	Exclusive OR register to accumulator	68-6F	1	1
XRL A,direct	Exclusive OR direct byte to accumulator	65	2	1
XRL A,@Ri	Exclusive OR indirect RAM to accumulator	66-67	1	1
XRL A,#data	Exclusive OR immediate data to accumulator	64	2	1
XRL direct,A	Exclusive OR accumulator to direct byte	62	2	1
XRL direct,#data	Exclusive OR immediate data to direct byte	63	3	2
CLR A	Clear accumulator	E4	1	1
CPL A	Complement accumulator	F4	1	1
RL A	Rotate accumulator left	23	1	1
RLC A	Rotate accumulator left through carry	33	1	1
RR A	Rotate accumulator right	03	1	1
RRC A	Rotate accumulator right through carry	13	1	1
SWAP A	Swap nibbles within the accumulator	C4	1	1

Table 2-3: Data transfer

Mnemonic	Description	Code	Bytes	Cycles
MOV A,Rn	Move register to accumulator	E8-EF	1	1
MOV A,direct	Move direct byte to accumulator	E5	2	1
MOV A,@Ri	Move indirect RAM to accumulator	E6-E7	1	1
MOV A,#data	Move immediate data to accumulator	74	2	1
MOV Rn,A	Move accumulator to register	F8-FF	1	1
MOV Rn,direct	Move direct byte to register	A8-AF	2	2
MOV Rn,#data	Move immediate data to register	78-7F	2	1
MOV direct,A	Move accumulator to direct byte	F5	2	1
MOV direct,Rn	Move register to direct byte	88-8F	2	2
MOV direct1,direct2	Move direct byte to direct byte	85	3	2
MOV direct,@Ri	Move indirect RAM to direct byte	86-87	2	2
MOV direct,#data	Move immediate data to direct byte	75	3	2
MOV @Ri,A	Move accumulator to indirect RAM	F6-F7	1	1
MOV @Ri,direct	Move direct byte to indirect RAM	A6-A7	2	2
MOV @Ri,#data	Move immediate data to indirect RAM	76-77	2	1
MOV DPTR,#data16	Load data pointer with a 16-bit constant	90	3	2
MOVX A,@Ri	Move external RAM (8-bit addr.) to A	E2-E3	1	2
MOVX A,@DPTR	Move external RAM (16-bit addr.) to A	E0	1	2
MOVX @Ri,A	Move A to external RAM (8-bit addr.)	F2-F3	1	2
MOVX @DPTR,A	Move A to external RAM (16-bit addr.)	F0	1	2
MOVC A,@A+DPTR	Move code byte relative to DPTR to accumulator	93	1	2
MOVC A,@A+PC	Move code byte relative to PC to accumulator	83	1	2
PUSH direct	Push direct byte onto stack	C0	2	2
POP direct	Pop direct byte from stack	D0	2	2
XCH A,Rn	Exchange register with accumulator	C8-CF	1	1
XCH A,direct	Exchange direct byte with accumulator	C5	2	1
XCH A,@Ri	Exchange indirect RAM with accumulator	C6-C7	1	1
XCHD A,@Ri	Exchange low-order nibble indir. RAM with A	D6-D7	1	1

Table 2-4: Program branches

Mnemonic	Description	Code	Bytes	Cycles
ACALL addr11	Absolute subroutine call	xxx11	2	2
LCALL addr16	Long subroutine call	12	3	2
RET	from subroutine	22	1	2
RETI	from interrupt	32	1	2
AJMP addr11	Absolute jump	xxx01	2	2
LJMP addr16	Long jump	02	3	2
SJMP rel	Short jump (relative addr.)	80	2	2
JMP @A+DPTR	Jump indirect relative to the DPTR	73	1	2
JZ rel	Jump if accumulator is zero	60	2	2
JNZ rel	Jump if accumulator is not zero	70	2	2
JC rel	Jump if carry flag is set	40	2	2
JNC	Jump if carry flag is not set	50	2	2
JB bit,rel	Jump if direct bit is set	20	3	2
JNB bit,rel	Jump if direct bit is not set	30	3	2
JBC bit,direct rel	Jump if direct bit is set and clear bit	10	3	2
CJNE A,direct rel	Compare direct byte to A and jump if not equal	B5	3	2
CJNE A,#data rel	Compare immediate to A and jump if not equal	B4	3	2
CJNE Rn,#data rel	Compare immed. to reg. and jump if not equal	B8-BF	3	2
CJNE @Ri,#data rel	Compare immed. to ind. and jump if not equal	B6-B7	3	2
DJNZ Rn,rel	Decrement register and jump if not zero	D8-DF	2	2
DJNZ direct,rel	Decrement direct byte and jump if not zero	D5	3	2
NOP	No operation	00	1	1

Table 2-5: Boolean manipulation

Mnemonic	Description	Code	Bytes	Cycles
CLR C	Clear carry flag	C3	1	1
CLR bit	Clear direct bit	C2	2	1
SETB C	Set carry flag	D3	1	1
SETB bit	Set direct bit	D2	2	1
CPL C	Complement carry flag	B3	1	1
CPL bit	Complement direct bit	B2	2	1
ANL C,bit	AND direct bit to carry flag	82	2	2
ANL C,/bit	AND complement of direct bit to carry	B0	2	2
ORL C,bit	OR direct bit to carry flag	72	2	2
ORL C,/bit	OR complement of direct bit to carry	A0	2	2
MOV C,bit	Move direct bit to carry flag	A2	2	1
MOV bit,C	Move carry flag to direct bit	92	2	2

### 3. Memory Structure

The SM5953 memory structure follows general 8052 structure. It is 15KB program memory.

#### 3.1 Program Memory

The SM5953 has 15KB on-chip flash memory which can be used as general program memory or EEPROM, on which include up to 3.875K byte specific ISP service program memory space. The address range for the 15K byte is \$0000h to \$3BFFh. The address range for the ISP service program is \$3000h to \$3F7Fh. The ISP service program size can be partitioned as N blocks (N=0 to 8). When N = 1 means address \$3E00h to \$3F7Fh reserved for ISP service program. When N=2 means memory address \$3C00h to \$3F7Fh reserved for ISP service program...etc. Value N can be set and programmed into SM5953 configuration by writer. As shown in Fig. 3-1.

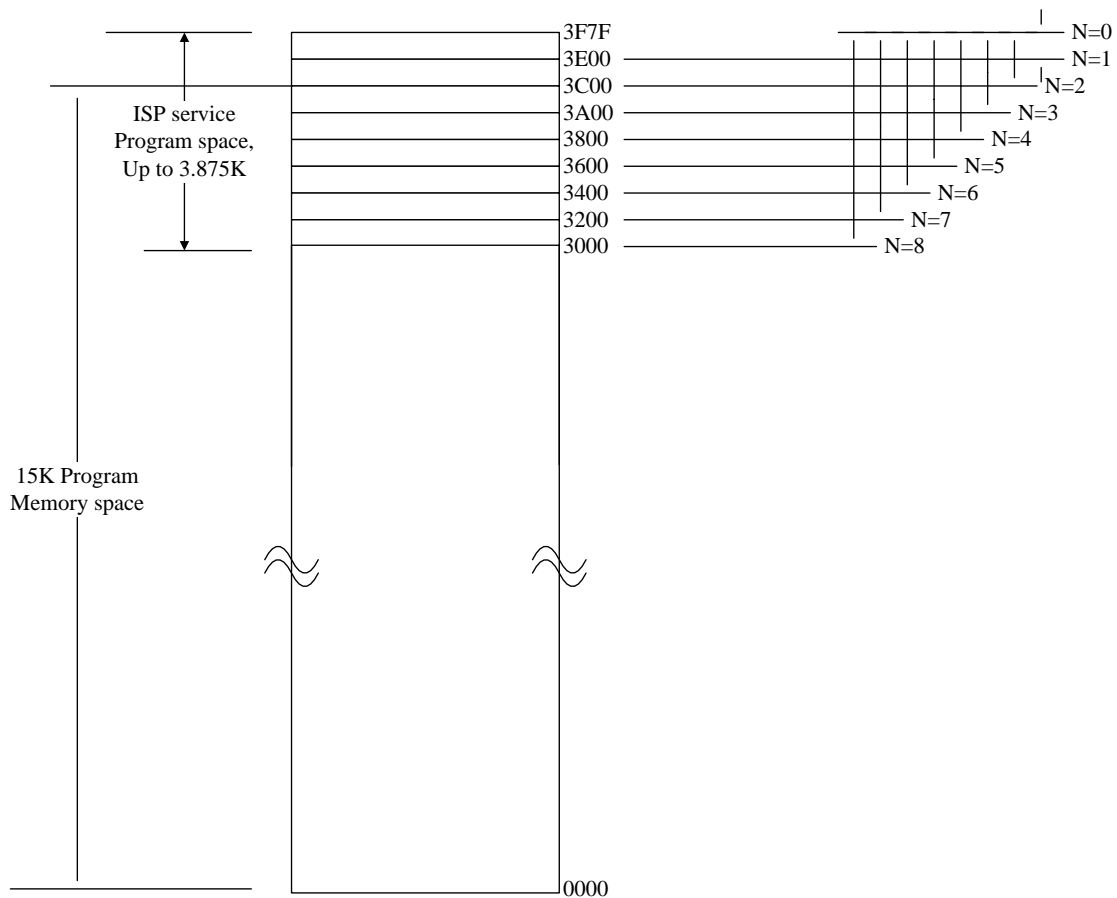

Fig. 3-1: SM5953 programmable Flash



### 3.2 Data Memory

The SM5953 has 256B on-chip SRAM. As shown in Fig. 3-2

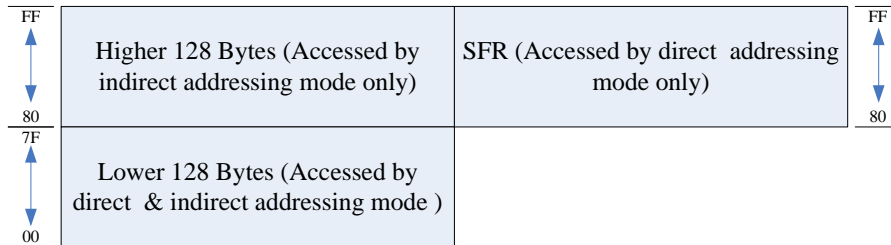

Fig. 3-2: RAM architecture

### 3.3 Data memory - lower 128 byte (00h to 7Fh)

Data memory 00h to FFh is the same as 8052.

The address 00h to 7Fh can be accessed by direct and indirect addressing modes.

Address 00h to 1Fh is register area.

Address 20h to 2Fh is memory bit area.

Address 30h to 7Fh is for general memory area.

### 3.4 Data memory - higher 128 byte (80h to FFh)

The address 80h to FFh can be accessed by indirect addressing mode.

Address 80h to FFh is data area.

## 4. CPU Engine

The SM5953 engine is composed of four components:

- (1) Control unit
- (2) Arithmetic – logic unit
- (3) Memory control unit
- (4) RAM and SFR control unit

The SM5953 engine allows to fetch instruction from program memory and to execute using RAM or SFR. The following chapter describes the main engine register.

Mnemonic	Description	Dir.	Bit 7	Bit 6	Bit 5	Bit 4	Bit 3	Bit 2	Bit 1	Bit 0	RST
8051 Core											
ACC	Accumulator	E0h	ACC.7	ACC.6	ACC.5	ACC.4	ACC.3	ACC.2	ACC.1	ACC.0	00H
B	B register	F0h	B.7	B.6	B.5	B.4	B.3	B.2	B.1	B.0	00H
PSW	Program status word	D0h	CY	AC	F0	RS[1:0]		OV	PSW.1	P	00H
SP	Stack Pointer	81h	SP[7:0]								07H
DPL	Data pointer low	82h	DPL[7:0]								00H
DPH	Data pointer high	83h	DPH[7:0]								00H

### 4.1 Accumulator

ACC is the Accumulator register. Most instructions use the accumulator to store the operand.

<b>Mnemonic: ACC</b>								<b>Address: E0h</b>	
7	6	5	4	3	2	1	0	Reset	
ACC.7	ACC.6	ACC.5	ACC.4	ACC.3	ACC.2	ACC.1	ACC.0	00h	

ACC[7:0]: The A (or ACC) register is the standard 8052 accumulator.

### 4.2 B Register

The B register is used during multiply and divide instructions. It can also be used as a scratch pad register to store temporary data.

<b>Mnemonic: B</b>								<b>Address: F0h</b>	
7	6	5	4	3	2	1	0	Reset	
B.7	B.6	B.5	B.4	B.3	B.2	B.1	B.0	00h	

B[7:0]: The B register is the standard 8052 register that serves as a second accumulator.

### 4.3 Program Status Word

Mnemonic: PSW							Address: D0h	
7	6	5	4	3	2	1	0	Reset
CY	AC	F0	RS [1:0]		OV	F1	P	00h

CY: Carry flag.

AC: Auxiliary Carry flag for BCD operations.

F0: General purpose Flag 0 available for user.

RS[1:0]: Register bank select, used to select working register bank.

RS[1:0]	Bank Selected	Location
00	Bank 0	00h – 07h
01	Bank 1	08h – 0Fh
10	Bank 2	10h – 17h
11	Bank 3	18h – 1Fh

OV: Overflow flag.

F1: General purpose Flag 1 available for user.

P: Parity flag, affected by hardware to indicate odd/even number of “one” bits in the Accumulator, i.e. even parity.

### 4.4 Stack Pointer

The stack pointer is a 1-byte register initialized to 07h after reset. This register is incremented before PUSH and CALL instructions, causing the stack to start from location 08h.

Mnemonic: SP							Address: 81h	
7	6	5	4	3	2	1	0	Reset
SP [7:0]								07h

SP[7:0]: The Stack Pointer stores the scratchpad RAM address where the stack begins. In other words, it always points to the top of the stack.

### 4.5 Data Pointer

The data pointer (DPTR) is 2-bytes wide. The lower part is DPL, and the highest is DPH. It can be loaded as a 2-byte register (e.g. MOV DPTR, #data16) or as two separate registers (e.g. MOV DPL, #data8). It is generally used to access the external code or data space (e.g. MOVC A, @A+DPTR or MOVX A, @DPTR respectively).

Mnemonic: DPL							Address: 82h	
7	6	5	4	3	2	1	0	Reset
DPL [7:0]								00h

DPL[7:0]: Data pointer Low

Mnemonic: DPH							Address: 83h	
7	6	5	4	3	2	1	0	Reset
DPH [7:0]								00h

DPH [7:0]: Data pointer High

## 5. GPIO

Port 0 ~ Port 3 are the general purpose IO of this controller. Most of the ports are multiplexed with the other outputs, e.g., Port 3[0] is also used as RXD in the UART application. Port0 is open-drain in the input and output high condition, so external pull-up resistors are required. As for the other ports, the pull-up resistors are built internally.

For general purpose applications, every pin can be assigned to either high or low independently because their SFRs are bit addressable as given below :

<b>Mnemonic: P0</b>								<b>Address: 80h</b>	
7	6	5	4	3	2	1	0	Reset	
P0.7	P0.6	P0.5	P0.4	P0.3	P0.2	P0.1	P0.0	FFh	

P0.7~ 0: Port0 [7] ~ Port0[0]

<b>Mnemonic: P1</b>								<b>Address: 90h</b>	
7	6	5	4	3	2	1	0	Reset	
P1.7	P1.6	P1.5	P1.4	P1.3	P1.2	P1.1	P1.0	FFh	

P1.7~ 0: Port1 [7] ~ Port1 [0]

<b>Mnemonic: P2</b>								<b>Address: A0h</b>	
7	6	5	4	3	2	1	0	Reset	
P2.7	P2.6	P2.5	P2.4	P2.3	P2.2	P2.1	P2.0	FFh	

P2.7~ 0: Port2 [7] ~ Port2 [0]

<b>Mnemonic: P3</b>								<b>Address: B0h</b>	
7	6	5	4	3	2	1	0	Reset	
P3.7	P3.6	P3.5	P3.4	P3.3	P3.2	P3.1	P3.0	FFh	

P3.7~ 0: Port3 [7] ~ Port3 [0]

## 6. Timer 0 and Timer 1

The SM5953 has three 16-bit timer/counter registers: Timer 0, Timer 1 and Timer 2. All can be configured for counter or timer operations.

In timer mode, the Timer 0 register or Timer 1 register is incremented every machine cycles, due to 12 oscillator periods in a machine cycle, the count rate is 1/12 of the oscillator frequency. If in 6T mode, the count rate is 1/6 of the oscillator frequency.

In counter mode, the register is incremented when the falling edge is observed at the corresponding input pin T0 or T1. Since it takes 2 machine cycles to recognize a 1-to-0 event, the maximum input count rate is 1/2 of the oscillator frequency. There are no restrictions on the duty cycle, however to ensure proper recognition of 0 or 1 state, an input should be stable for at least 1 machine cycle.

Four operating modes can be selected for Timer 0 and Timer 1. Two Special Function registers (TMOD and TCON) are used to select the appropriate mode.

Mnemonic	Description	Dir.	Bit 7	Bit 6	Bit 5	Bit 4	Bit 3	Bit 2	Bit 1	Bit 0	RST
Timer 0 and 1											
TL0	Timer 0 , low byte	8Ah					TL0[7:0]				00H
TH0	Timer 0 , high byte	8Ch					TH0[7:0]				00H
TL1	Timer 1 , low byte	8Bh					TL1[7:0]				00H
TH1	Timer 1 , high byte	8Dh					TH1[7:0]				00H
TMOD	Timer Mode Control	89h	GATE	C/T	M1	M0	GATE	C/T	M1	M0	00H
TCON	Timer/Counter Control	88h	TF1	TR1	TF0	TR0	IE1	IT1	IE0	IT0	00H

### 6.1 Timer/counter mode control register (TMOD)

Mnemonic: TMOD								Address: 89h	
7	6	5	4	3	2	1	0	Reset	
GATE	C/T	M1	M0	GATE	C/T	M1	M0	00h	
Timer 1				Timer 0					

**GATE:** If set, enables external gate control (pin INT0 or INT1 for Counter 0 or 1, respectively). When INT0 or INT1 is high, and TRx bit is set (see TCON register), a counter is incremented every falling edge on T0 or T1 input pin.

**C/T:** Selects Timer or Counter operation. When set to 1, a counter operation is performed, when cleared to 0, the corresponding register will function as a timer.

M1	M0	Mode	Function
0	0	Mode0	13-bit counter/timer, with 5 lower bits in TL0 or TL1 register and 8 bits in TH0 or TH1 register (for Timer 0 and Timer 1, respectively). The 3 high order bits of TL0 and TL1 are hold at zero.
0	1	Mode1	16-bit counter/timer.
1	0	Mode2	8-bit auto-reload counter/timer. The reload value is kept in TH0 or TH1, while TL0 or TL1 is incremented every machine cycle. When TLx overflows, a value from THx is copied to TLx.

Specifications subject to change without notice contact your sales representatives for the most recent information.

1	1	Mode3	If Timer 1 M1 and M0 bits are set to 1, Timer 1 stops. If Timer 0 M1 and M0 bits are set to 1, Timer 0 acts as two independent 8 bit timers / counters.
---	---	-------	---

## 6.2 Timer/counter control register (TCON)

Mnemonic: TCON							Address: 88h	
7	6	5	4	3	2	1	0	Reset
TF1	TR1	TF0	TR0	IE1	IT1	IE0	IT0	00h

TF1: Timer 1 overflow flag set by hardware when Timer 1 overflows. This flag can be cleared by software and is automatically cleared when interrupt is processed.

TR1: Timer 1 Run control bit. If cleared, Timer 1 stops.

TF0: Timer 0 overflow flag set by hardware when Timer 0 overflows. This flag can be cleared by software and is automatically cleared when interrupt is processed.

TR0: Timer 0 Run control bit. If cleared, Timer 0 stops.

IE1: Interrupt 1 edge flag. Set by hardware, when falling edge on external pin INT1 is observed. Cleared when interrupt is processed.

IT1: Interrupt 1 type control bit. Selects falling edge or low level on input pin to cause interrupt. IT1=1, interrupt 1 select falling edge trigger. IT1=0, interrupt1 select low level trigger.

IE0: Interrupt 0 edge flag. Set by hardware, when falling edge on external pin INT0 is observed. Cleared when interrupt is processed.

IT0: Interrupt 0 type control bit. Selects falling edge or low level on input pin to cause interrupt. IT0=1, interrupt 0 select falling edge trigger. IT0=0, interrupt 0 select low level trigger.

## 6.3 Mode 0 (13-bit Counter/Timer)

The timer register is configured as a 13-bit register. As the count rolls over from all 1s to all 0s, it sets the timer interrupt flag TF<sub>x</sub>. The counted input is enabled to the timer when TR<sub>x</sub> = 1 and either GATE=0 or INT<sub>x</sub> = 1. Mode 0 operation is the same for Timer0 and Timer1.

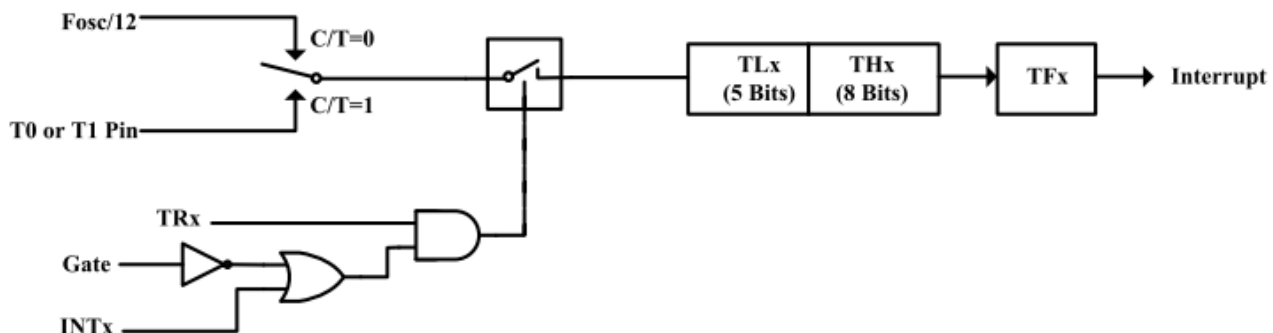

Fig. 6-1: Mode 0 -13 bit Timer / counter operation

Specifications subject to change without notice contact your sales representatives for the most recent information.

#### 6.4 Mode 1 (16-bit Counter/Timer)

Mode1 is the same as Mode0, except that the timer register is being run with all 16 bits.

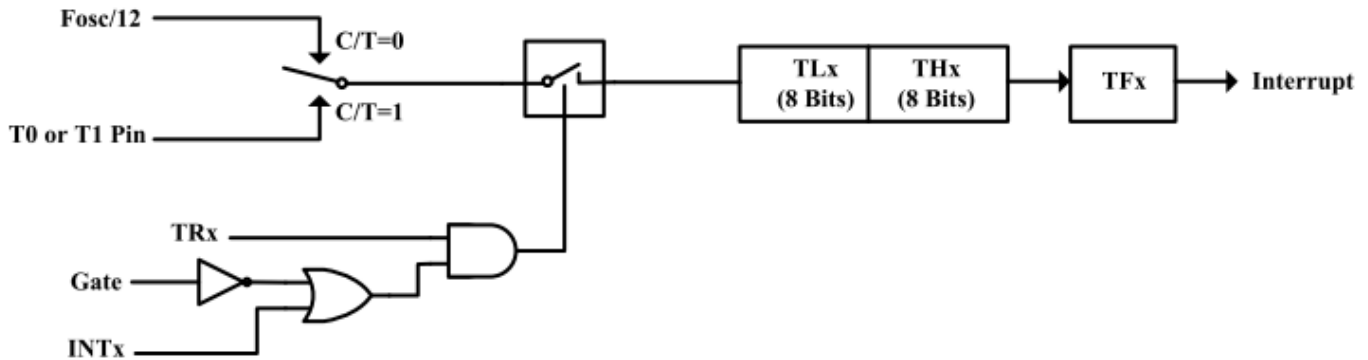

Fig. 6-2: Mode 1 16 bit Counter/Timer operation

#### 6.5 Mode 2 (8-bit auto-reload Counter/Timer)

Mode 2 configures the timer register as an 8-bit counter (TLx) with automatic reload. Overflow from TLx not only set TFX, but also reload TLx with the content of THx, which is determined by software. The reload leaves THx unchanged. Mode 2 operation is the same for Timer0 and Timer1.

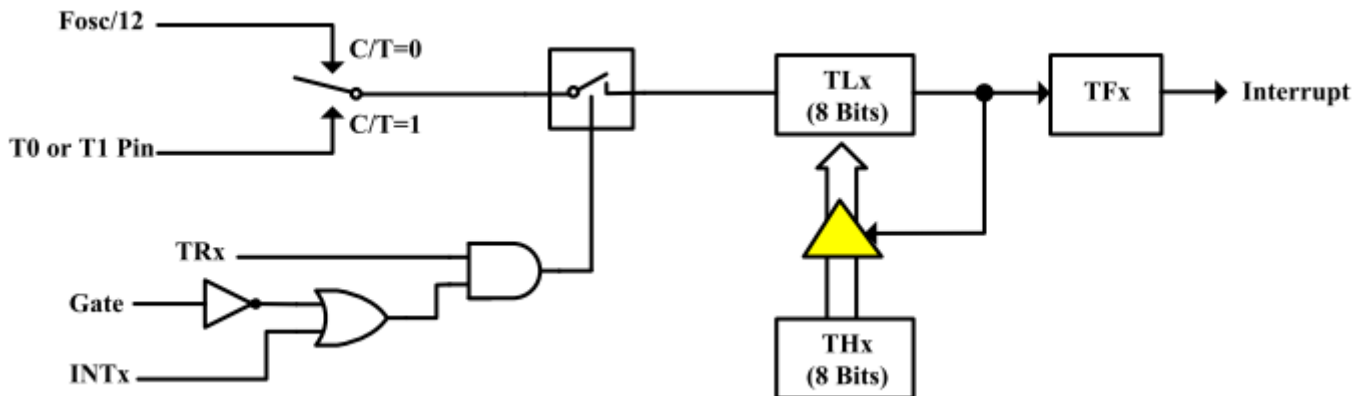

Fig. 6-3: Mode 2 8-bit auto-reload Counter/Timer operation.

#### 6.6 Mode 3 (Timer 0 acts as two independent 8 bit Timers / Counters)

Timer1 in Mode3 simply holds its count, the effect is the same as setting TR1 = 1. Timer0 in Mode 3 enables TL0 and TH0 as two separate 8-bit counters. TL0 uses the Timer0 control bits such like C/T, GATE, TR0, INT0 and TF0. TH0 is locked into a timer function (can not be external event counter) and take over the use of TR1, TF1 from Timer1. TH0 now controls the Timer1 interrupt.

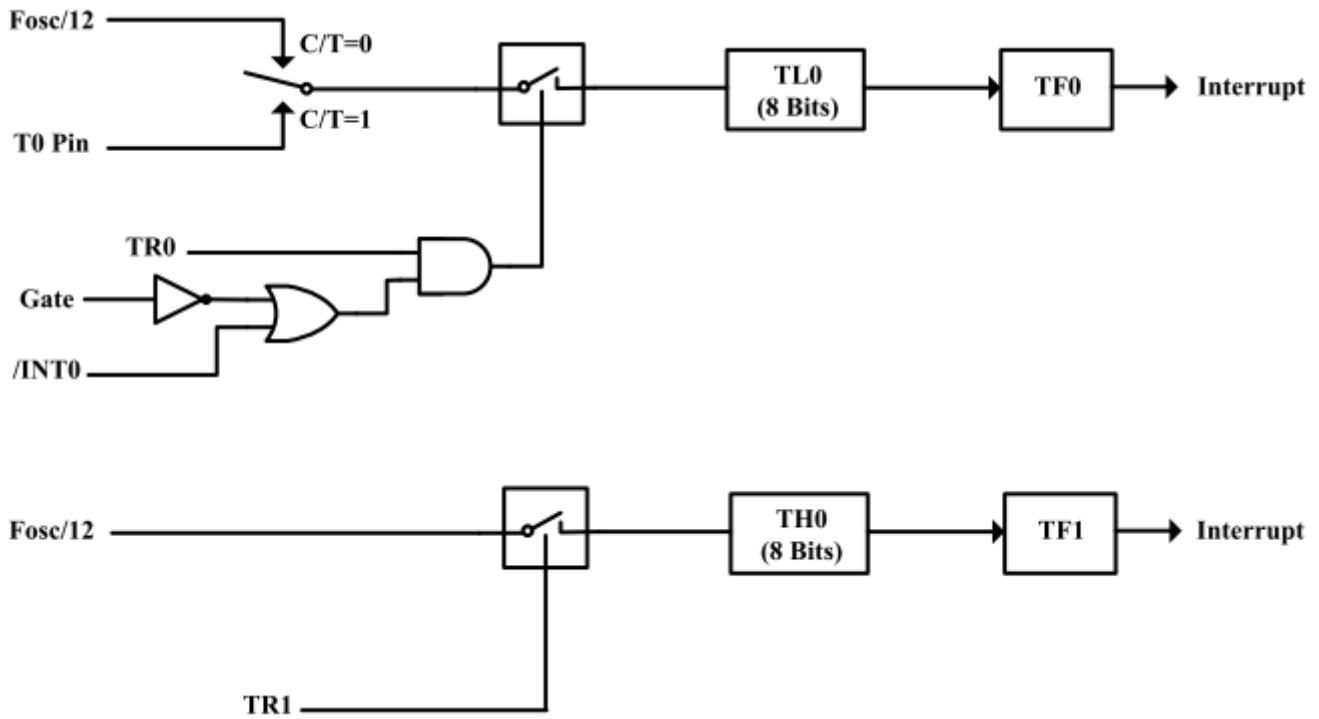

Fig. 6-4: Mode 3 Timer 0 acts as two independent 8 bit Timers / Counters operatin



## 7. Timer 2

Timer2 is a 16-bit timer/counter which can operate as either an event timer or an event counter as selected by C/T2 in the special function register T2CON.

Mnemonic	Description	Dir.	Bit 7	Bit 6	Bit 5	Bit 4	Bit 3	Bit 2	Bit 1	Bit 0	RST
Serial interface 0 and 1											
TL2	Timer 2, low byte	CCh	TL2[7:0]								00h
TH2	Timer 2, high byte	CDh	TH2[7:0]								00h
RCAP2L	Reload and capture data low byte	CAh	RCAP2L[7:0]								00h
RCAP2H	Reload and capture data high byte	CBh	RCAP2H[7:0]								00h
T2MOD	Timer 2 mode	C9h	-	-	-	-	-	-	T2OE	DCEN	x0h
T2CON	Timer 2 control register	C8h	TF2	EXF2	RCLK	TCLK	EXEN <sub>2</sub>	TR2	C/ $\overline{T2}$	CP/ $\overline{RL2}$	00h

**Mnemonic: T2MOD**

**Address: 98h**

7	6	5	4	3	2	1	0	Reset
-	-	-	-	-	-	T2OE	DCEN	00H

T2OE: Timer 2 Output Enable bit. It enables Timer2 overflow rate to toggle P1.0.

DCEN: Down Count Enable bit. When set, this allows Timer2 to be configured as an up/down Counter.

**Mnemonic: T2CON**

**Address: 98h**

7	6	5	4	3	2	1	0	Reset
TF2	EXF2	RCLK	TCLK	EXEN <sub>2</sub>	TR2	C/ $\overline{T2}$	CP/ $\overline{RL2}$	00H

TF2: Timer 2 overflow flag is set by a Timer 2 overflow and must be cleared by software. TF2 will not be set when either RCLK = 1 or TCLK = 1.

EXF2: Timer 2 external flag is set when either a capture or reload is caused by a negative transition on T2EX and EXEN<sub>2</sub> = 1. When Timer 2 interrupt is enabled, EXF2 = 1 will cause the CPU to vector to the Timer 2 interrupt routine. EXF2 must be cleared by software. EXF2 does not cause an interrupt in up/down counter mode (DCEN = 1).

RCLK: Receive clock enable. When set, causes the serial port to use Timer 2 overflow pulses for its receive clock in serial port Modes 1 and 3. RCLK = 0 causes Timer 1 overflows to be used for the receive clock.

TCLK: Transmit clock enable. When set, causes the serial port to use Timer 2 overflow pulses for its transmit clock in serial port Modes 1 and 3. TCLK = 0 causes Timer 1 overflows to be used for the transmit clock.

Specifications subject to change without notice contact your sales representatives for the most recent information.

**EXEN2:** Timer 2 external enable. When set, allows a capture or reload to occur as a result of a negative transition on T2EX if Timer 2 is not being used to clock the serial port. EXEN2 = 0 causes Timer 2 to ignore events at T2EX.

**TR2:** Start/Stop control for Timer 2. TR2 = 1 starts the timer.

**C/T2:** Timer or counter select for Timer 2.  $\overline{C/T2} = 0$  for timer function.  $\overline{C/T2} = 1$  for external event counter (falling edge triggered).

**CP/RL2:** Capture/Reload select.  $\overline{CP/RL2} = 1$  causes captures to occur on negative transitions at T2EX if EXEN2 = 1.  $\overline{CP/RL2} = 0$  causes automatic reloads to occur when Timer 2 overflows or negative transitions occur at T2EX when EXEN2 = 1. When either RCLK or TCLK = 1, this bit is ignored and the timer is forced to auto-reload on Timer 2 overflow.

Table 7-1 : Timer 2 Operating Modes

RCLK + TCLK	CP/RL2	TR2	DCEN	Mode
x	x	0	x	OFF
1	x	1	0	Baud-Rate Generation
0	1	1	0	Capture
0	0	1	0	Auto-Reload Up-only
0	0	1	1	Auto-Reload Up/Down

### 7.1 Capture mode

In the capture mode, there are two options selected by bit EXEN2 in T2CON. If EXEN2 = 0, Timer 2 is a 16-bit timer or counter which upon overflow sets bit TF2 in T2CON. This bit can then be used to generate an interrupt. If EXEN2 = 1, Timer 2 still does the above, but with the added feature that a 1-to-0 transition at external input T2EX causes the current value in TH2 and TL2 to be captured into RCAP2H and RCAP2L, respectively. In addition, the transition at T2EX causes bit EXF2 in T2CON to be set. The EXF2 bit, like TF2, can generate an interrupt.

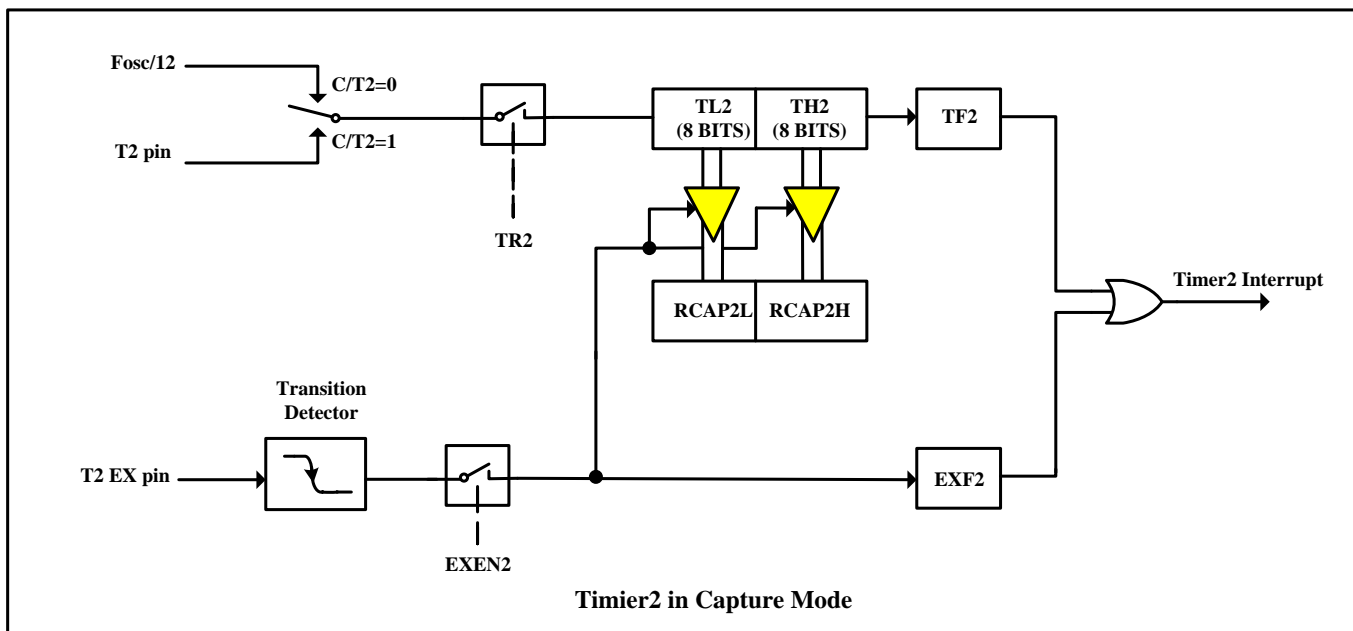

Fig. 7-1 : Timer 2 in capture mode

## 7.2 Auto-reload (Up or Down Counter)

Timer 2 can be programmed to count up or down when configured in its 16-bit auto-reload mode. This feature is invoked by a bit named DCEN (Down Counter Enable) located in the SFR T2MOD. Upon reset, the DCEN bit is set to 0 so that Timer 2 will default to count up. When DCEN is set, Timer 2 can count up or down depending on the value of the T2EX pin.

Fig. 7-2 shows Timer 2 automatically counting up when DCEN = 0. In this mode there are two options selected by bit EXEN2 in T2CON. If EXEN2 = 0, Timer 2 counts up to FFFFh and then sets the TF2 bit upon overflow. The overflow also causes the timer registers to be reloaded with the 16-bit value in RCAP2H and RCAP2L. The values in RCAP2H and RCAP2L are preset by software. If EXEN2 = 1, a 16-bit reload can be triggered either by an overflow or by a 1-to-0 transition at external input T2EX. This transition also sets the EXF2 bit. Both the TF2 and EXF2 bits can generate an interrupt if enabled.

Setting the DCEN bit enables Timer 2 to count up or down as shown in Fig. 7-3. In this mode the T2EX pin controls the direction of count. A logic 1 at T2EX makes Timer 2 count up. The timer will overflow at FFFFh and set the TF2 bit. This overflow also causes the 16-bit value in RCAP2H and RCAP2L to be reloaded into the timer registers, TH2 and TL2, respectively.

A logic 0 at T2EX makes Timer 2 count down. Now the timer underflows when TH2 and TL2 are equal to the values stored in RCAP2H and RCAP2L. The underflow sets the TF2 bit and causes FFFFh to be reloaded into the timer registers.

The EXF2 bit toggles whenever Timer 2 overflows or underflows. This bit can be used as a 17th bit of resolution if desired. In this operating mode, EXF2 does not flag an interrupt.

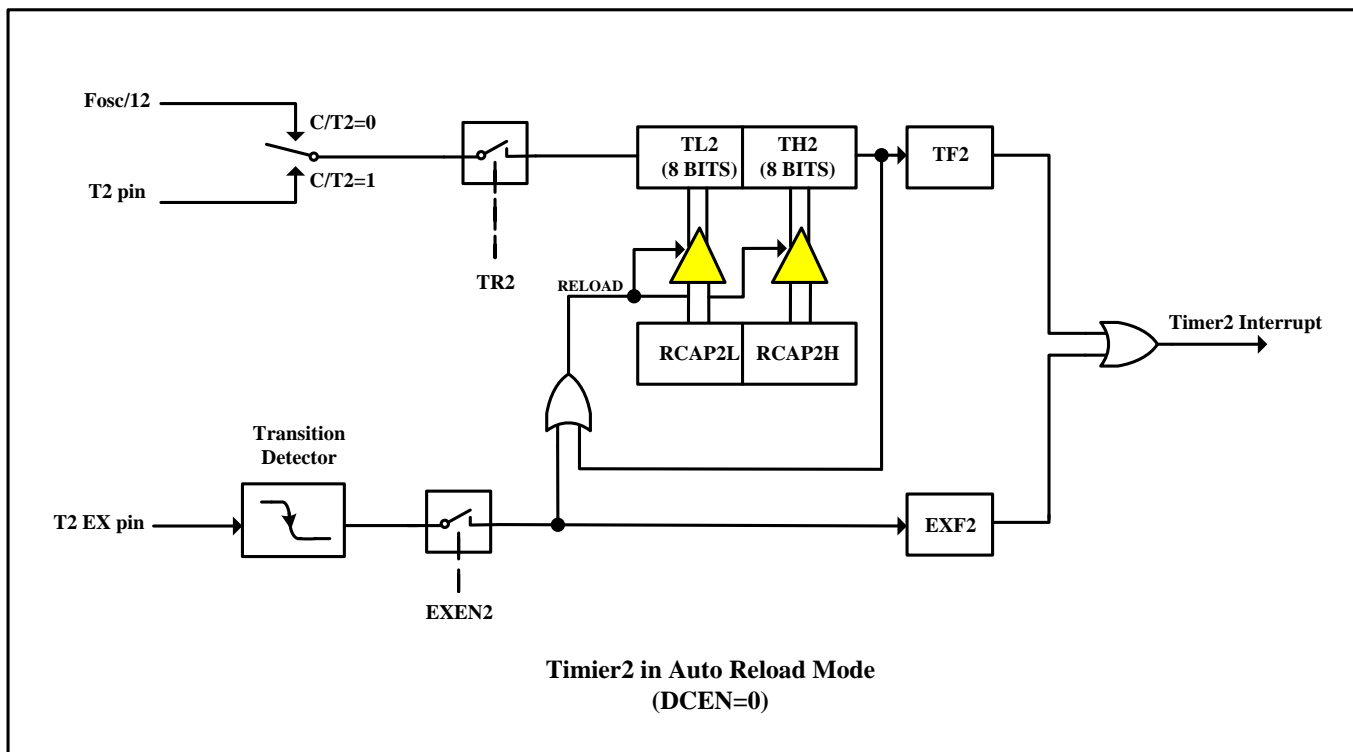

Fig. 7-2 : Timer 2 in auto reload mode (DCEN=0)

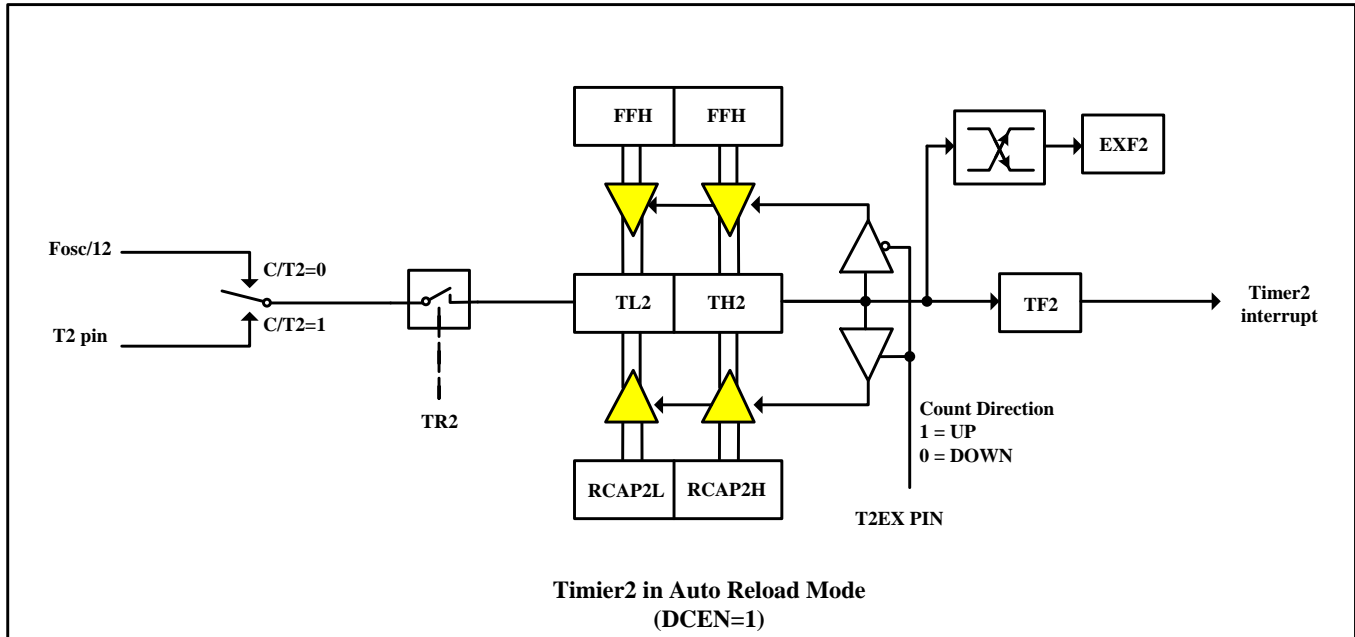

Fig. 7-3 : Timer 2 in auto reload mode (DCEN=1)

### 7.3 Programmable clock out

A 50% duty cycle clock can be programmed to come out on P1.0. This pin, besides being a regular I/O pin, has two alternate functions. It can be programmed (1) to input the external clock for Timer/Counter 2 or (2) to output a 50% duty cycle clock. An example is that the clock output ranges from 61Hz to 4MHz at a 16MHz oscillator frequency if in 12T mode.

To configure the Timer/Counter 2 as a clock generator, bit  $C/\overline{T2}$  (T2CON.1) must be cleared and bit T2OE (T2MOD.1) must be set. Bit TR2 (T2CON.2) starts and stops the timer.

The Clock-Out frequency depends on the oscillator frequency and the reload value of Timer 2 capture registers (RCAP2H, RCAP2L) as shown in this equation:

$$\text{Clock-Out Frequency} = \frac{\text{Oscillator Frequency}}{4 \times (65536 - RCAP2H, RCAP2L)}$$

In the clock-out mode, Timer 2 roll-overs will not generate an interrupt. This is similar to when Timer 2 is used as a baud-rate generator. It is possible to use Timer 2 as a baud-rate generator and a clock generator simultaneously. Note, however, that the baud-rate and clock-out frequencies can not be determined independently from one another since they both use RCAP2H and RCAP2L.

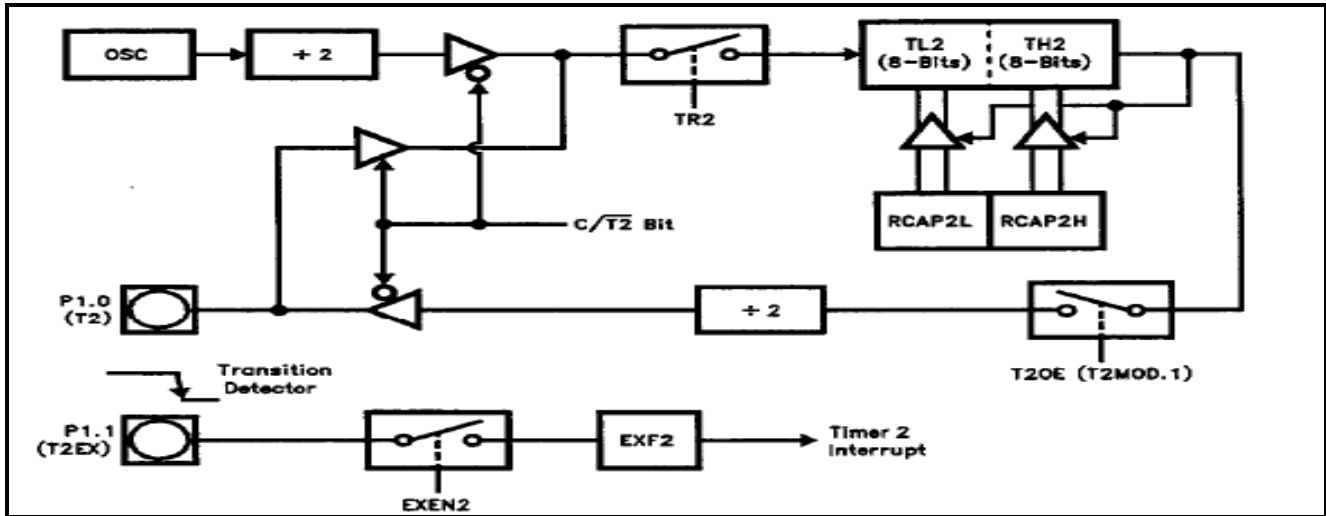

Fig. 7-4 : Timer 2 in clock-out mode

## 8. Serial interface – UART

The serial buffer consists of two separate registers, a Transmit buffer and a receive buffer.

Writing data to the Special Function Register SBUF sets this data in serial output buffer and starts the transmission. Reading from the SBUF reads data from the serial receive buffer. The serial port can simultaneously Transmit and receive data. It can also buffer 1 byte at receive, which prevents the receive data from being lost if the CPU reads the first byte before transmission of the second byte is completed.

Mnemonic	Description	Dir.	Bit 7	Bit 6	Bit 5	Bit 4	Bit 3	Bit 2	Bit 1	Bit 0	RST
Serial interface 0 and 1											
PCON	Power control	87H	SMOD	-	-	-	GF1	GF0	PD	IDLE	00H
SCON	Serial Port control register	98H	SM0	SM1	SM2	REN	TB8	RB8	TI	RI	00H
SBUF	Serial Port data buffer	99H	SBUF[7:0]								00H

<b>Mnemonic: SCON</b>								<b>Address: 98h</b>	
7	6	5	4	3	2	1	0	Reset	
SM0	SM1	SM2	REN	TB8	RB8	TI	RI	00H	

SM0, SM1: Serial Port 0 mode selection.

SM0	SM1	Mode
0	0	0
0	1	1
1	0	2
1	1	3

The 4 modes in UART, Mode 0 ~ 3, are explained later.

SM2: Enables multiprocessor communication feature

REN: If set, enables serial reception. Cleared by software to disable reception.

TB8: The 9th transmitted data bit in modes 2 and 3. Set or cleared by the CPU depending on the function it performs such as parity check, multiprocessor communication etc.

RB8: In modes 2 and 3, it is the 9th data bit received. In mode 1, if SM2 is 0, RB8 is the stop bit. In mode 0, this bit is not used. Must be cleared by software.

TI: Transmit interrupt flag, set by hardware after completion of a serial transfer. Must be cleared by software.

RI: Receive interrupt flag, set by hardware after completion of a serial reception. Must be cleared by software.

### 8.1 Serial interface

The Serial Interface can operate in the following 4 modes:

SM0	SM1	Mode	Description	Board Rate
0	0	0	Shift register	Fosc/12
0	1	1	8-bit UART	Variable
1	0	2	9-bit UART	Fosc/32 or Fosc/64
1	1	3	9-bit UART	Variable

Specifications subject to change without notice contact your sales representatives for the most recent information.

Here Fosc is the crystal or oscillator frequency.

The serial port of Maryland is full duplex, can transmit and receive simultaneously. The serial port receive and transmit share the same SFR – SBUF, but actually there is two SBUF in the chip, one is for transmit and the other is for receive. The serial port can be operated in 4 different modes.

### 8.1.1 Mode 0

Pin RXD serves as input and output. TXD outputs the shift clock. 8 bits are transmitted with LSB first. The baud rate is fixed at 1/12 of the crystal frequency. Reception is initialized in Mode 0 by setting the flags in SCON as follows: RI = 0 and REN = 1. In other modes, a start bit when REN = 1 starts receiving serial data. As shown in Fig. 8-1 and Fig. 8-2



Fig. 8-1: Transmit mode 0

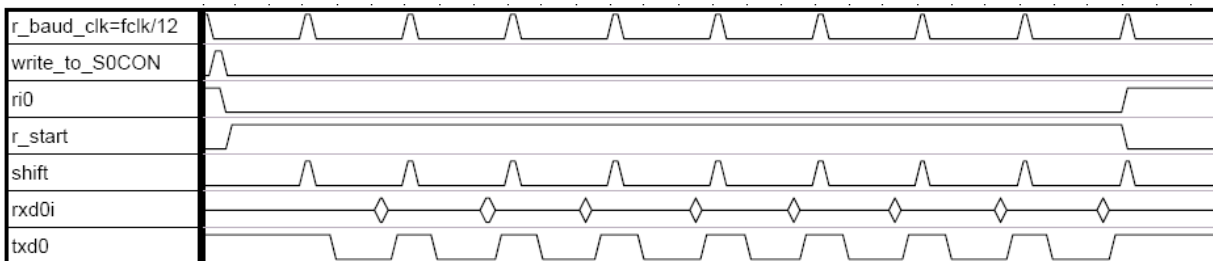

Fig. 8-2: Receive mode 0

### 8.1.2 Mode 1

Pin RXD serves as input, and TXD serves as serial output. No external shift clock is used, 10 bits are transmitted: a start bit (always 0), 8 data bits (LSB first), and a stop bit (always 1). On receive, a start bit synchronizes the transmission, 8 data bits are available by reading SBUF, and stop bit sets the flag RB8 in the Special Function Register SCON. In mode 1 either internal baud rate generator or timer 1 can be use to specify baud rate. As shown in Fig. 8-3 and Fig. 8-4



Fig. 8-3: Transmit mode 1

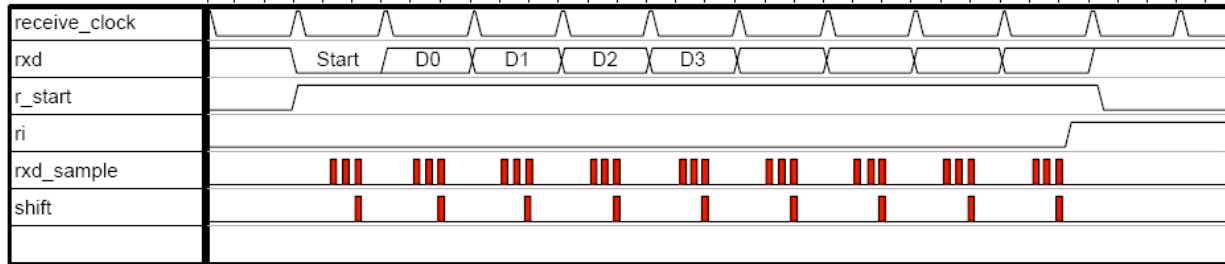

Fig. 8-4: Receive mode 1

### 8.1.3 Mode 2

This mode is similar to Mode 1, with two differences. The baud rate is fixed at 1/32 (SMOD=1) or 1/64 (SMOD=0) of oscillator frequency and 11 bits are transmitted or received: a start bit (0), 8 data bits (LSB first), a programmable 9th bit, and a stop bit (1). The 9th bit can be used to control the parity of the serial interface: at transmission, bit TB8 in SCON is output as the 9th bit, and at receive, the 9th bit affects RB8 in Special Function Register SCON.

### 8.1.4 Mode 3

The only difference between Mode 2 and Mode 3 is that in Mode 3 either internal baud rate generator or timer 1 can be used to specify baud rate. As shown in Fig. 8-5 and Fig. 8-6.



Fig. 8-5: Transmit modes 2 and 3

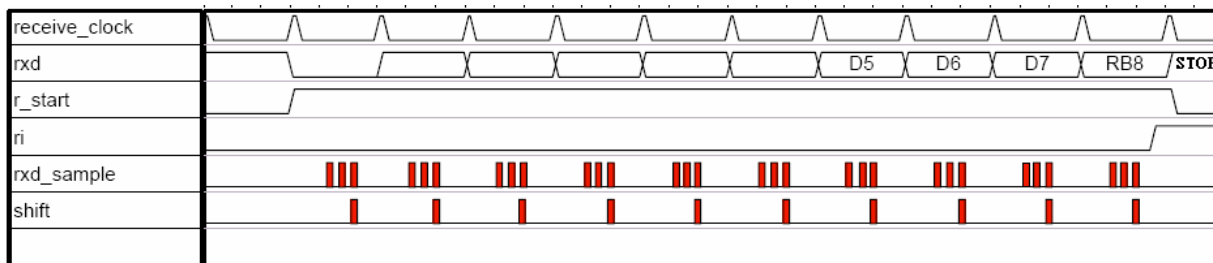

Fig. 8-6: Receive modes 2 and 3

## 8.2 Multiprocessor Communication of Serial Interface

The feature of receiving 9 bits in Modes 2 and 3 of Serial Interface can be used for multiprocessor communication. In this case, the slave processors have bit SM2 in SCON set to 1. When the master processor outputs slave's address, it sets the 9th bit to 1, causing a serial port receive interrupt in all the slaves. The slave processors compare the received byte with their network address. If there is a match, the addressed slave will clear SM2 and receive the rest of the message, while other slaves will leave SM2 bit unaffected and ignore this message. After addressing the slave, the host will output the rest of the message with the 9th bit set to 0, so no serial port receive interrupt will be generated in unselected slaves.





### 8.3 Baud Rate Generator

#### 8.3.1 Serial interface Mode 0

$$\text{Baud Rate} = \frac{F_{osc}}{12}$$

#### 8.3.2 Serial interface Mode 2

$$\text{Baud Rate} = \frac{2^{SMOD}}{64} \times (F_{osc})$$

#### 8.3.3 Serial interface Mode 1 and 3

##### 8.3.3.1 Using Timer 1 to Generate Baud Rates.

$$\text{Baud Rate} = \frac{2^{SMOD}}{32} \times (\text{Timer 1 overflow rate}) = \frac{2^{SMOD}}{32} \times \frac{F_{osc}}{12 \times [256 - TH1]}$$

##### 8.3.3.2 Using Timer 2 to Generate Baud Rates.

$$\text{Baud Rate} = \frac{\text{Timer 2 overflow rate}}{32} = \frac{F_{osc}}{32 \times [65536 - (\text{RCAP2H}, \text{RCAP2L})]}$$

## 9. Interrupt

The SM5953 provides 6 interrupt sources with two priority levels. Each source has its own request flag(s) located in a special function register. Each interrupt requested by the corresponding flag could individually be enabled or disabled by the enable bits in SFR's IE.

When the interrupt occurs, the engine will vector to the predetermined address as given in Table 9-1. Once interrupt service has begun, it can be interrupted only by a higher priority interrupt. The interrupt service is terminated by a return from instruction RETI. When an RETI is performed, the processor will return to the instruction that would have been next when interrupt occurred.

When the interrupt condition occurs, the processor will also indicate this by setting a flag bit. This bit is set regardless of whether the interrupt is enabled or disabled. Each interrupt flag is sampled once per machine cycle, and then samples are polled by hardware. If the sample indicates a pending interrupt when the interrupt is enabled, then interrupt request flag is set. On the next instruction cycle the interrupt will be acknowledged by hardware forcing an LCALL to appropriate vector address.

Interrupt response will require a varying amount of time depending on the state of microcontroller when the interrupt occurs. If microcontroller is performing an interrupt service with equal or greater priority, the new interrupt will not be invoked. In other cases, the response time depends on current instruction.

Table 9-1: Interrupt vectors

Priority level	Interrupt Request Flags	Interrupt Vector Address	Interrupt Number *(use Keil C Tool)
1 (highest)	IE0 – External interrupt 0	0003h	0
2	TF0 – Timer 0 interrupt	000Bh	1
3	IE1 – External interrupt 1	0013h	2
4	TF1 – Timer 1 interrupt	001Bh	3
5	RI0/TI 0– Serial channel 0 interrupt	0023h	4
6	TF2/EXF2 – Timer 2 interrupt	002Bh	5

\*See Keil C about C51 User's Guide about Interrupt Function description

Mnemonic	Description	Dir.	Bit 7	Bit 6	Bit 5	Bit 4	Bit 3	Bit 2	Bit 1	Bit 0	RST
Interrupt											
IE	Interrupt Enable register	A8H	EA	-	ET2	ES	ET1	EX1	ET0	EX0	00H
IP	Interrupt priority register	B8H	-	-	PT2	PS	PT1	PX1	PT0	PX0	00H

Mnemonic: IE						Address: A8h					
7	6	5	4	3	2	1	0	Reset			
EA	-	ET2	ES	ET1	EX1	ET0	EX0	00h			

EA: EA=0 – Disable all interrupt.

EA=1 – Enable all interrupt.

ET2: ET2=0 – Disable Timer 2 overflow or external reload interrupt.

ET2=1 – Enable Timer 2 overflow or external reload interrupt.

ES: ES=0 – Disable Serial channel interrupt.

ES=1 – Enable Serial channel interrupt.

Specifications subject to change without notice contact your sales representatives for the most recent information.



ET1: ET1=0 – Disable Timer 1 overflow interrupt.

ET1=1 – Enable Timer 1 overflow interrupt.

EX1: EX1=0 – Disable external interrupt 1.

EX1=1 – Enable external interrupt 1.

ET0: ET0=0 – Disable Timer 0 overflow interrupt.

ET0=1 – Enable Timer 0 overflow interrupt.

EX0: EX0=0 – Disable external interrupt 0.

EX0=1 – Enable external interrupt 0.

Mnemonic: IP							Address: B8h		
7	6	5	4	3	2	1	0	Reset	
-	-	PT2	PS	PT1	PX1	PT0	PX0	00H	

PT2: Timer2 interrupt priority bit.

PS: Serial port interrupt priority bit.

PT1: Timer1 interrupt priority bit.

PX1: External interrupt 1 priority bit.

PT0: Timer 0 interrupt priority bit.

PX0: External interrupt 0 priority bit.

Interrupt Priority Table

IP.x	Priority Level
1	1 (highest)
0	2

## 10. Watch Dog Timer

The Watch Dog Timer (WDT) is an 16-bit free-running counter that generate reset signal if the counter overflows. The WDT is useful for systems which are susceptible to noise, power glitches, or electronics discharge which causing software dead loop or runaway. The WDT function can help user software recover from abnormal software condition. The WDT is different from Timer0, Timer1 and Timer2 of general 8052. To prevent a WDT reset can be done by software periodically clearing the WDT counter. User should check WDR bit of SCONF register whenever un-predicted reset happened. After an external reset the watchdog timer is disabled and all registers are set to zeros.

The WDT has selectable divider input for the time base source clock. To select the divider input, the setting of bit2 ~ bit0 (PS[2:0]) of Watch Dog Timer Control Register (WDTC) should be set accordingly. As shown in Table 10-1.

To enable the WDT is done by setting 1 to the bit 7 (WDTE) of WDTC. After WDTE set to 1, the 16-bit counter starts to count with the selected time base source clock which set by PS2-PS0. It will generate a reset signal when overflows. The WDTE bit will be cleared to 0 automatically when SM5953 been reset, either hardware reset or WDT reset.

To reset the WDT is done by setting 1 to the bit 5 (CLEAR) of WDTC. This will clear the content of the 16-bit counter and let the counter re-start to count from the beginning.

Table 10-1: WDT time-out period

PS[2:0]	Divider (dividing of Fosc)	Time period @ 40MHz
000	8	13.1ms
001	16	26.21ms
010	32	52.42ms
011	64	104.8ms
100	128	209.71ms
101	256	419.43ms
110	512	838.86ms
111	1024	1677.72ms

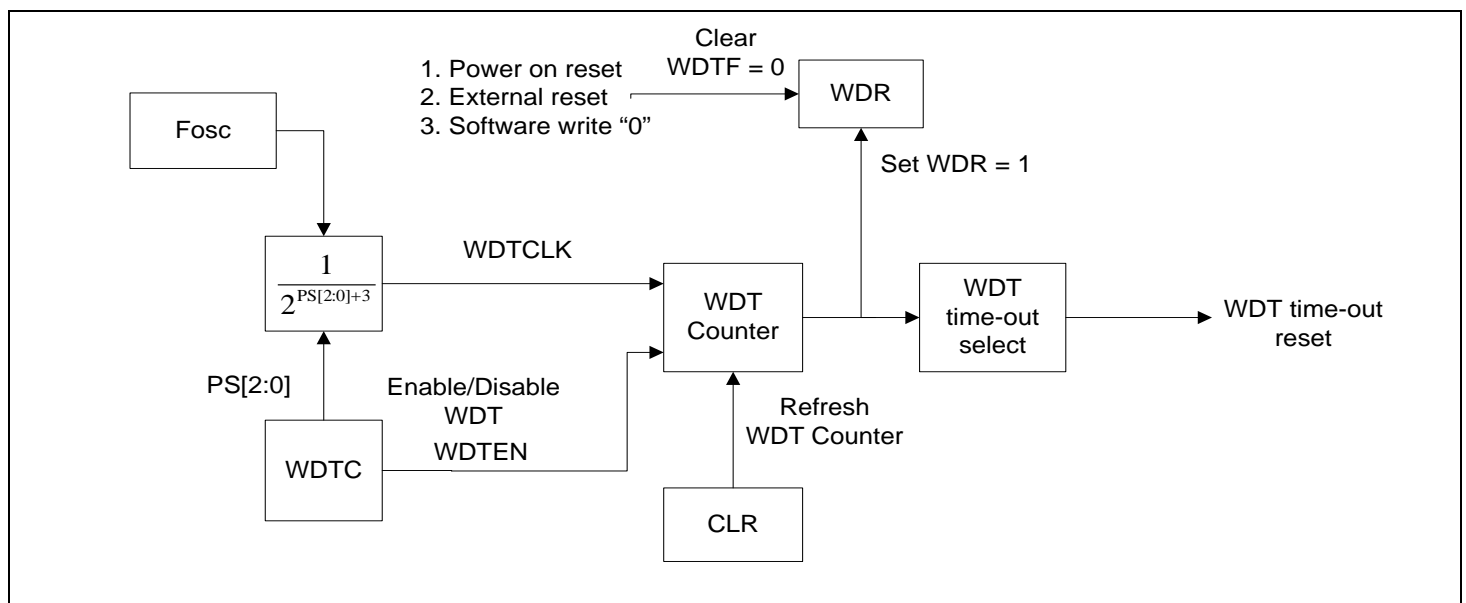

Fig. 10-1: Watchdog timer block diagram



Mnemonic	Description	Dir.	Bit 7	Bit 6	Bit 5	Bit 4	Bit 3	Bit 2	Bit 1	Bit 0	RST
Watchdog Timer											
WDTC	Watchdog timer control register	9FH	WDTE	-	CLEAR	-	-	PS [2:0]			00H
SCONF	System Control Register	BFH	WDR	-	-	-	-	ISPE	-	ALEI	00H

**Mnemonic: WDTC**

**Address: 9Fh**

7	6	5	4	3	2	1	0	Reset
WDTE	-	CLEAR	-	-	PS [2:0]			00H

WDTE: Watch Dog Timer enable bit.

CLEAR: Watch Dog Timer clear bit.

If CLEAR bit set to 1, setting this bit the Watchdog timer counter clear and re-start to count from the Beginning.

PS[2:0]: Watch Dog timer over flow period setting.

**Mnemonic: SCONF**

**Address: BFh**

7	6	5	4	3	2	1	0	Reset
WDR	-	-	-	-	ISPE	-	ALEI	00H

WDR Watch Dog Timer Reset.

When system reset by Watch Dog Timer overflow, WDR will be set to 1.

User should check WDR bit whenever un-predicted reset happened.

## 11. Power Management Unit

Power management unit serves two power management modes, Idle and Power Down, for the users to do power saving function.

Mnemonic: PCON							Address: 87h	
7	6	5	4	3	2	1	0	Reset
SMOD	-	-	-	GF1	GF0	PD	IDLE	00h

GF1: General-purpose flag bit.

GF0: General-purpose flag bit.

PD: Power Down mode control bit. Setting this bit turning on the PD Mode.

PD bit is always read as 0

IDLE: Idle mode control bit. Setting this bit turning on the Idle Mode.

Idle bit is always read as 0

### 11.1 Idle mode

An instruction that sets PCON.0 causes that to be the last instruction executed before going into the idle mode, the internal clock is gated off to the CPU but not to the interrupt, timer and serial port functions.

There are two ways to terminate the idle. Activation of any enabled interrupt will cause PCON.0 to be cleared by hardware, terminating the idle mode. The interrupt will be serviced, and following RETI, the next instruction to be executed will be the one following the instruction that put the device into idle. Another way to wake-up from idle is to pull RESET high to generate internal hardware reset.

### 11.2 Power Down mode

An instruction that sets PCON.1 cause that to be the last instruction executed before going into the Power-Down mode. In the power-down mode, the on-chip oscillator is stopped. The contents of on-chip RAM and SFRs are maintained. Be carefully to keep RESET pin active for at least 10ms in order for a stable clock.

The power-down mode can be woken-up by RESET pin. When it is woken-up by RESET, the program will execute from the address 0000H.

Pin Status in IDLE Mode and Power-Down Mode

Mode	Program Memory	ALE	PSEN	Port0	Port1	Port2	Port3
Idle	Internal	1	1	Data	Data	Data	Data
Idle	External	1	1	Float	Data	Address	Data
Power-Down	Internal	0	0	Data	Data	Data	Data
Power-Down	External	0	0	Float	Data	Data	Data

## 12. In-System Programming (Internal ISP)

The SM5953 can generate flash control signal by internal hardware circuit. Users utilize flash control register, flash address register and flash data register to perform the ISP function without removing the SM5953 from the system. The SM5953 provides internal flash control signals which can do flash program/chip erase/page erase/protect functions. User need to design and use any kind of interface which SM5953 can input data. User then utilize ISP service program to perform the flash program/chip erase/page erase/protect functions.

### 12.1 ISP service program

The ISP service program is a user developed firmware program which resides in the ISP service program space. After user developed the ISP service program, user then determine the size of the ISP service program. User need to program the ISP service program in the SM5953 for the ISP purpose.

The ISP service programs were developed by user so that it should includes any features which relates to the flash memory programming function as well as communication protocol between SM5953 and host device which output data to the SM5953. For example, if user utilize UART interface to receive/transmit data between SM5953 and host device, the ISP service program should include baud rate, checksum or parity check or any error-checking mechanism to avoid data transmission error.

### 12.2 Lock Bit (N)

The Lock Bit N has two functions: one is for service program size configuration and the other is to lock the ISP service program space from flash erase function.

The ISP service program space address range \$3000 to \$3F7F. It can be divided as blocks of N. (N=0 to 8). When N=0 means no ISP function. The maximum ISP service program allowed is 3.875K byte when N=8.

The lock bit N function is different from the flash protect function. The flash erase function can erase all of the flash memory except for the locked ISP service program space. If the flash not has been protected, the content of ISP service program still can be read. If the flash has been protected, the overall content of flash program memory space including ISP service program space can not be read. As given in Table 12-1.

Table 12-1 ISP code area

	<b>ISP service program address</b>
0	No ISP service program
1	384 bytes (\$3E00h ~ \$3F7Fh)
2	896K bytes (\$3C00h ~ \$3F7Fh)
3	1.375K bytes (\$3A00h ~ \$3F7Fh)
4	1.875K bytes (\$3800h ~ \$3F7Fh)
5	2.375K bytes (\$3600h ~ \$3F7Fh)
6	2.875K bytes (\$3400h ~ \$3F7Fh)
7	3.375K bytes (\$3200h ~ \$3F7Fh)
8	3.875K bytes (\$3000h ~ \$3F7Fh)

ISP service program configurable in N (N= 0 ~ 8)

### 12.3 Program the ISP Service Program

After Lock Bit N is set and ISP service program been programmed, the ISP service program memory will be protected (locked) automatically. The lock bit N has its own program/erase timing. It is different from the flash memory program/erase timing so the locked ISP service program can not be erased by flash erase function. If user needs to erase the locked ISP service program, he can do it by writer only. User can not change ISP service program when SM5953 was in system.

### 12.4 Initiate ISP Service Program

To initiate the ISP service program is to load the program counter (PC) with start address of ISP service program and execute it. There are four ways to do so:

- (1) Blank reset. Hardware reset with first flash address blank (\$0000=#FFH) will load the PC with start address of ISP service program.
- (2) Execute jump instruction can load the start address of the ISP service program to PC.
- (3) RESET is asserted with P2.6 and P2.7 both at low state. User can change enable or disable by writer.

During the strobe window, the hardware will detect the status of P2.6 and P2.7. If they meet one of above conditions, chip will switch to ISP mode automatically. After ISP service program executed, user need to reset the SM5953, either by hardware reset or by WDT, or jump to the address \$0000 to re-start the firmware program.

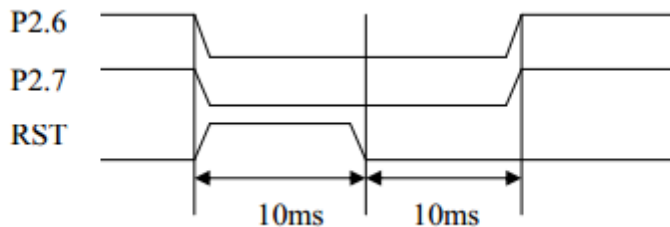

### 12.5 ISP register – ISPF AH, ISPFAL, ISPF D and ISPC

Mnemonic	Description	Dir.	Bit 7	Bit 6	Bit 5	Bit 4	Bit 3	Bit 2	Bit 1	Bit 0	RST	
ISP function												
ISPF AH	ISP Flash Address – High register	F4h	ISPF AH [7:0]									00H
ISPFAL	ISP Flash Address - Low register	F5h	ISPFAL [7:0]									00H
ISPF D	ISP Flash Data register	F6h	ISPF D [7:0]									00H
ISPC	ISP Control register	F7h	START	-	-	-	-	-	ISPF [1:0]		00H	

**Mnemonic: ISPF AH**

**Address: F4H**

7	6	5	4	3	2	1	0	Reset
ISPF AH7	ISPF AH6	ISPF AH5	ISPF AH4	ISPF AH3	ISPF AH2	ISPF AH1	ISPF AH0	00H

ISPF AH [7:0]: Flash address-high for ISP function



Mnemonic: ISPFAL							Address: F5H	
7	6	5	4	3	2	1	0	Reset
ISPFAL7	ISPFAL6	ISPFAL5	ISPFAL4	ISPFAL3	ISPFAL2	ISPFAL1	ISPFAL0	00H

ISPFAL [7:0]: Flash address-Low for ISP function

The ISPFAL & ISPFAL provide the 16-bit flash memory address for ISP function. The flash memory address should not include the ISP service program space address. If the flash memory address indicated by ISPFAL & ISPFAL registers overlay with the ISP service program space address, the flash program/page erase of ISP function executed thereafter will have no effect.

Mnemonic: ISPDF							Address: F6H	
7	6	5	4	3	2	1	0	Reset
ISPDF7	ISPDF6	ISPDF5	ISPDF4	ISPDF3	ISPDF2	ISPDF1	ISPDF0	00H

ISPDF [7:0]: Flash data for ISP function.

The ISPDF provide the 8-bit data register for ISP function.

Mnemonic: ISPC						Address: F7H		
7	6	5	4	3	2	1	0	Reset
START	-	-	-	-	-	ISPF[1:0]		00H

START: ISP function start bit

= 1: start ISP function which indicated by bit 1, bit 0 (ISPF[1:0])

= 0: no operation

ISPF [1:0]: ISP function select bit.

ISPF[1:0]	ISP function
00	Byte program
01	Chip protect
10	Page erase
11	Chip erase

One page of flash memory is 128byte

The choice ISP function will start to execute once the software write data to ISPC register.

To perform byte program/page erases ISP function, user need to specify flash address at first. When performing page erase function, SM5953 will erase entire page which flash address indicated by ISPFAL & ISPFAL registers located within the page.

e.g. flash address: \$ XY00

page erase function will erase from \$XY00 to \$XY7F

To perform the chip erase ISP function, SM5953 will erase all the flash program memory except the ISP service program space. To perform chip protect ISP function, the SM5953 flash memory content will be read #00H. The program will miss the interrupt if it happens during the ISP function.

e.g. ISP service program to do the byte program - to program #22H to the address \$1005H



```
CLR EA          ;disable interrupt
MOV ISPFDF, #55h
MOV ISPFDF, #0AAh
MOV ISPFDF, #55h ; enable ISPE write attribute
ORL SCONF, #04H ; enable ISP function
MOV ISPFAH, #10H ; set flash address-high, 10H
MOV ISPFAL, #05H ; set flash address-low, 05H
MOV ISPFDF, #22H ; set flash data to be programmed, data = 22H
MOV ISPC, #80H ; start to program #22H to the flash address $1005H
ANL SCONF, #0FBH ; disable ISP function
SETB EA        ; enable interrupt
```

## Operating Conditions

Symbol	Description	Min.	Typ.	Max.	Unit.	Remarks
TA	Operating temperature	-40	25	85	°C	Ambient temperature under bias
VDD	Supply voltage	2.4		5.5	V	

## DC Characteristics

TA = -40°C to 85°C, VCC = 5.0V

Symbol	Parameter	Valid	Min.	Max.	Unit	Test Conditions
VIL1	Input Low Voltage	port 0,1,2,3,#EA	-0.5	0.8	V	
VIL2	Input Low Voltage	RES, XTAL1	0	0.8	V	
VIH1	Input High Voltage	port 0,1,2,3,#EA	2.0	Vcc+0.5	V	
VIH2	Input High Voltage	RES, XTAL1	70%Vcc	Vcc+0.5	V	
VOL1	Output Low Voltage	port 0, ALE, #PSEN		0.45	V	IOL=3.2mA
VOL2	Output Low Voltage	port 1,2,3,		0.45	V	IOL=1.6mA
VOH1	Output High Voltage	port 0	2.4		V	IOH=-800uA
			90%Vcc		V	IOH=-80uA
VOH2	Output High Voltage	port 1,2,3,ALE,#PSEN	2.4		V	IOH=-60uA
			90%Vcc		V	IOH=-10uA
IIL	Logical 0 Input Current	port 1,2,3		-75	uA	Vin=0.45V
ITL	Logical Transition Current	port 1,2,3		-650	uA	Vin=2.0V
ILI	Input Leakage Current	port 0, #EA		±10	uA	0.45V<Vin<Vcc
R RES	Reset Pull-down Resistance	RES	50	300	Kohm	
C IO	Pin Capacitance			10	pF	Freq=1MHz, Ta=25 °C
I CC	Power Supply Current	Vdd		20	mA	Active mode, 16MHz
				6.5	mA	Idle mode, 16MHz
				15	uA	Power down mode