

Hex Schmitt inverter

Datasheet - production data

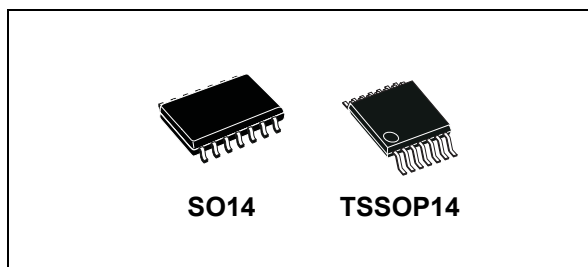

- Wide operating voltage range:
 $V_{CC} \text{ (opr)} = 2 \text{ to } 6 \text{ V}$
- Pin and function compatible with 74 series 14
- ESD performance
 - CDM: 1 kV
 - HBM: 2 kV
 - MM: 200 V

Features

- High speed:
 $t_{PD} = 12 \text{ ns (typ.) at } V_{CC} = 6 \text{ V}$
- Low power dissipation:
 $I_{CC} = 1 \mu\text{A (max.) at } T_A = 25 \text{ }^\circ\text{C}$
- High noise immunity:
 $V_H = 1.2 \text{ V (typ.) at } V_{CC} = 6 \text{ V}$
- Symmetrical output impedance:
 $|I_{OH}| = I_{OL} = 4 \text{ mA (min.)}$
- Balanced propagation delays:
 $t_{PLH} \cong t_{PHL}$

Description

The M74HC14 is a high speed CMOS hex Schmitt inverter fabricated with silicon gate C²MOS technology. Pin configuration and functions are the same as those of the M74HC04 but all inputs have a 20 % V_{CC} hysteresis level.

This, together with the Schmitt trigger function, allows the device to be used on line receivers with slow rise/fall input signals.

All inputs are equipped with protection circuits against static discharge and transient excess voltage.

Table 1. Device summary

Order code	Temperature range	Package	Packing	Marking
M74HC14RM13TR	-55 °C to +125 °C	SO14	Tape and reel	74HC14
M74HC14YRM13TR ⁽¹⁾	-40 °C to +125 °C	SO14 (automotive grade)		74HC14Y
M74HC14TTR	-55 °C to +125 °C	TSSOP14		HC14
M74HC14YTTR ⁽¹⁾	-40 °C to +125 °C	TSSOP14 (automotive grade)		HC14Y

1. Qualification and characterization according to AEC Q100 and Q003 or equivalent, advanced screening according to AEC Q001 and Q002.

Contents

1	Pin information	3
2	Functional description	4
3	Electrical characteristics	5
4	Package information	9
	4.1 SO14 package information	10
	4.2 TSSOP14 package information	12
5	Ordering information	14
6	Revision history	14

1 Pin information

Figure 1. Pin connections and IEC logic symbols

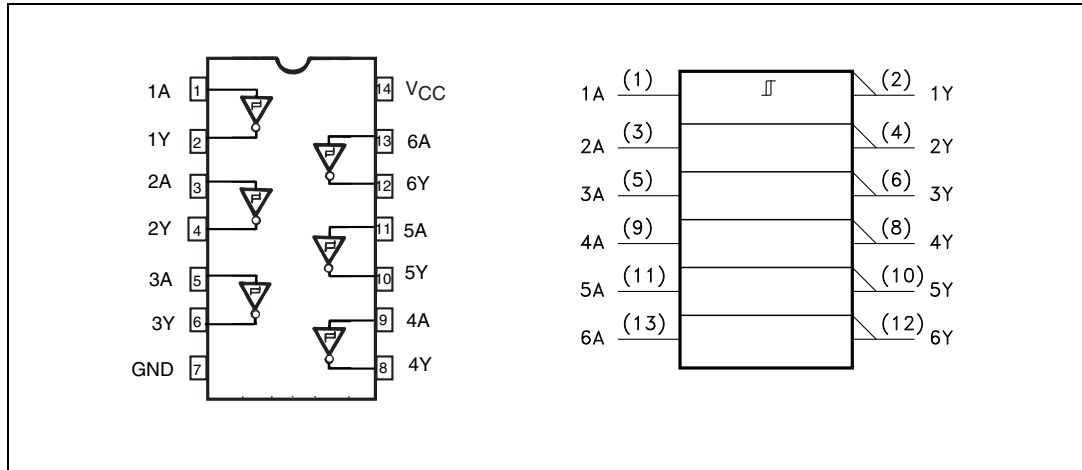

Table 2. Pin description

Pin number	Symbol	Name and function
1, 3, 5, 9, 11, 13	1A to 6A	Data inputs
2, 4, 6, 8, 10, 12	1Y to 6Y	Data outputs
7	GND	Ground (0 V)
14	V _{CC}	Positive supply voltage

2 Functional description

Table 3. Truth table

A	Y
L	H
H	L

Figure 2. Input and output equivalent circuit

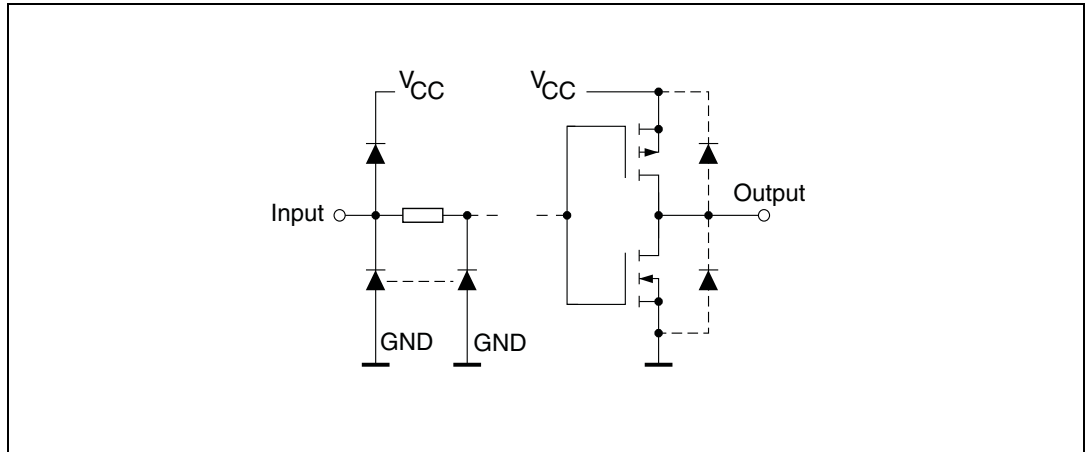

3 Electrical characteristics

Stressing the device above the ratings listed in the “Absolute maximum ratings” table may cause permanent damage to the device. These are stress ratings only, and operation of the device at these or any other conditions above those indicated in the operating sections of this specification are not implied. Exposure to absolute maximum rating conditions for extended periods may affect device reliability. Please refer to the STMicroelectronics SURE Program and other relevant quality documents.

Table 4. Absolute maximum ratings

Symbol	Parameter	Value	Unit
V_{CC}	Supply voltage	-0.5 to +7	V
V_I	DC input voltage	-0.5 to $V_{CC} + 0.5$	
V_O	DC output voltage		
I_{IK}	DC input diode current	± 20	mA
I_{OK}	DC output diode current		
I_O	DC output current	± 25	
I_{CC} or I_{GND}	DC V_{CC} or ground current	± 50	
P_D	Power dissipation	500 ⁽¹⁾	mW
T_{stg}	Storage temperature	-65 to +150	°C
T_L	Lead temperature (10 sec)	300	

1. 500 mW at 65 °C; derate to 300 mW by 10 mW/°C from 65 °C to 85 °C

Table 5. Recommended operating conditions

Symbol	Parameter	Value	Unit
V_{CC}	Supply voltage	2 to 6	V
V_I	Input voltage	0 to V_{CC}	
V_O	Output voltage		
T_{op}	Operating temperature	-55 to 125	°C

Table 6. DC specifications

Sym.	Parameter	Test condition		Value						Unit	
		V _{CC} (V)		T _A = 25 °C			-40 to 85 °C		-55 to 125 °C		
				Min	Typ	Max	Min	Max	Min		Max
V _{t+}	High level input voltage	2.0		1.0	1.28	1.5	1.0	1.5	1.0	1.5	V
		4.5		2.3	2.8	3.15	2.3	3.15	2.3	3.15	
		6.0		3.0	3.7	4.2	3.0	4.2	3.0	4.2	
V _{t-}	Low level input voltage	2.0		0.3	0.74	0.9	0.3	0.9	0.3	0.9	
		4.5		1.13	1.8	2.0	1.13	2.0	1.13	2.0	
		6.0		1.5	2.4	2.6	1.5	2.6	1.5	2.6	
V _H	Hysteresis voltage	2.0		0.3	0.54	1.0	0.3	1.0	0.3	1.0	
		4.5		0.6	1.0	1.4	0.6	1.4	0.6	1.4	
		6.0		0.8	1.3	1.4	0.8	1.7	0.8	1.7	
V _{OH}	High level output voltage	2.0	I _O = -20 μA	1.9	2.0		1.9		1.9		
		4.5		4.4	4.5		4.4		4.4		
		6.0		5.9	6.0		5.9		5.9		
		4.5	I _O = -4.0 mA	4.18	4.31		4.13		4.10		
		6.0	I _O = -5.2 mA	5.68	5.8		5.63		5.60		
V _{OL}	Low level output voltage	2.0	I _O = -20 μA		0.0	0.1		0.1		0.1	
		4.5			0.0	0.1		0.1		0.1	
		6.0			0.0	0.1		0.1		0.1	
		4.5	I _O = -4.0 mA		0.17	0.26		0.33		0.40	
		6.0	I _O = -5.2 mA		0.18	0.26		0.33		0.40	
I _I	Input leakage current	6.0	V _I = V _{CC} or GND			±0.1		±1		±1	μA
I _{CC}	Quiescent supply current					1		10		20	

Table 7. AC electrical characteristics
($C_L = 50 \text{ pF}$, Input $t_r = t_f = 6 \text{ ns}$)

Sym.	Parameter	Test condition		Value				Unit
		V_{CC} (V)		$T_A = 25 \text{ }^\circ\text{C}$		$-40 \text{ to } 85 \text{ }^\circ\text{C}$	$-55 \text{ to } 125 \text{ }^\circ\text{C}$	
				Typ	Max	Max	Max	
t_{TLH} t_{THL}	Output transition time	2.0		30	75	95	110	ns
		4.5		8	15	19	22	
		6.0		7	13	16	19	
t_{PLH} t_{PHL}	Propagation delay time	2.0		42	125	155	190	
		4.5		14	25	31	38	
		6.0		12	21	16	32	

Table 8. Capacitive characteristics

Sym	Parameter	Test condition		Value				Unit
		V_{CC} (V)		$T_A = 25 \text{ }^\circ\text{C}$		$-40 \text{ to } 85 \text{ }^\circ\text{C}$	$-55 \text{ to } 125 \text{ }^\circ\text{C}$	
				Typ	Max	Max	Max	
C_{IN}	Input capacitance	5.0		5	10	10	10	pF
C_{PD}	Power dissipation capacitance ⁽¹⁾		$f_{IN} = 10 \text{ MHz}$	28				

1. C_{PD} is defined as the value of the IC's internal equivalent capacitance which is calculated from the operating current consumption without load (refer to test circuit). Average operating current can be obtained by the following equation:
 $I_{CC(oper)} = C_{PD} \times V_{CC} \times f_{IN} + I_{CC}/6(\text{per gate})$.

Figure 3. Test circuit

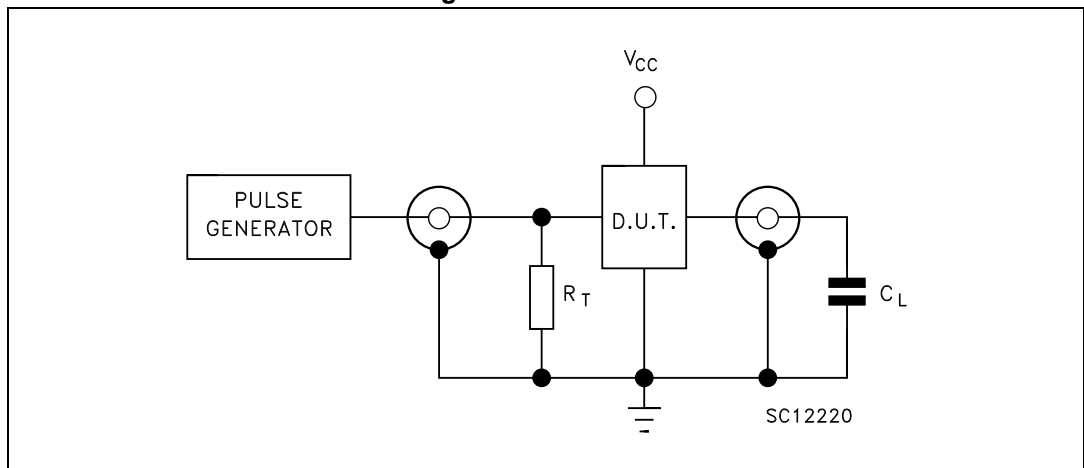
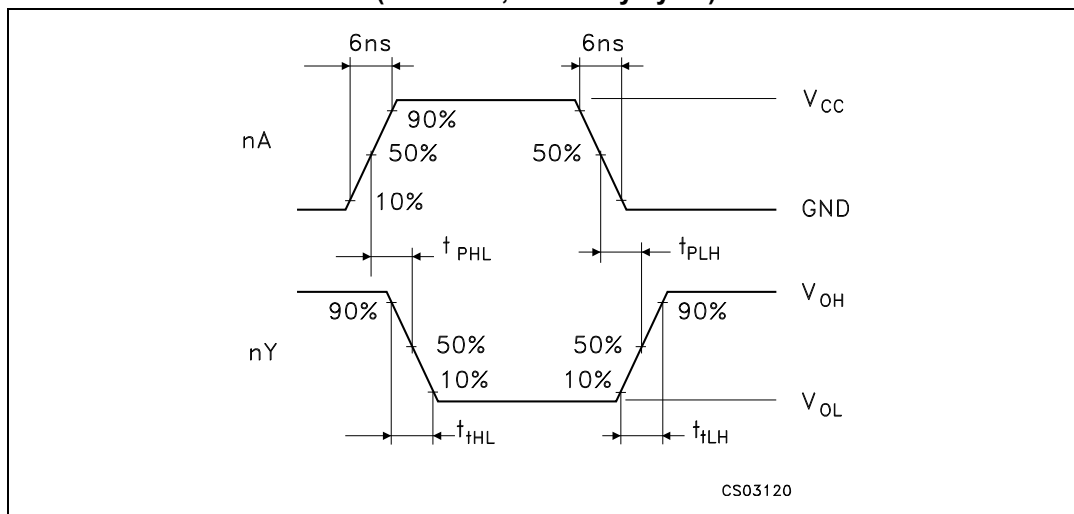

Figure 4. Waveform: propagation delay times
(f = 1 MHz; 50% duty cycle)



4 Package information

In order to meet environmental requirements, ST offers these devices in different grades of ECOPACK[®] packages, depending on their level of environmental compliance. ECOPACK[®] specifications, grade definitions and product status are available at: www.st.com. ECOPACK[®] is an ST trademark.

4.1 SO14 package information

Figure 5. SO14 package mechanical drawing

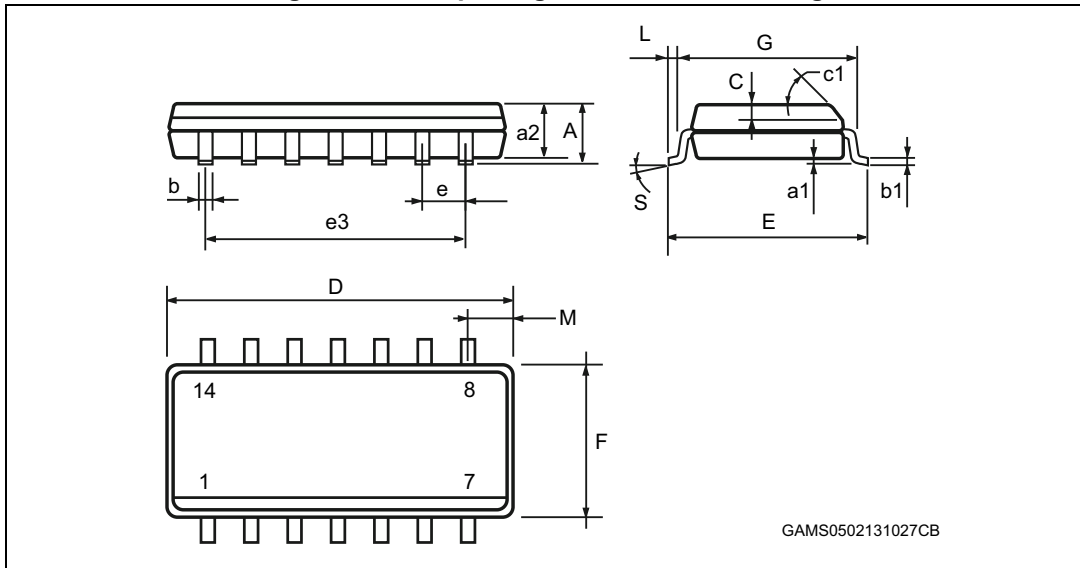
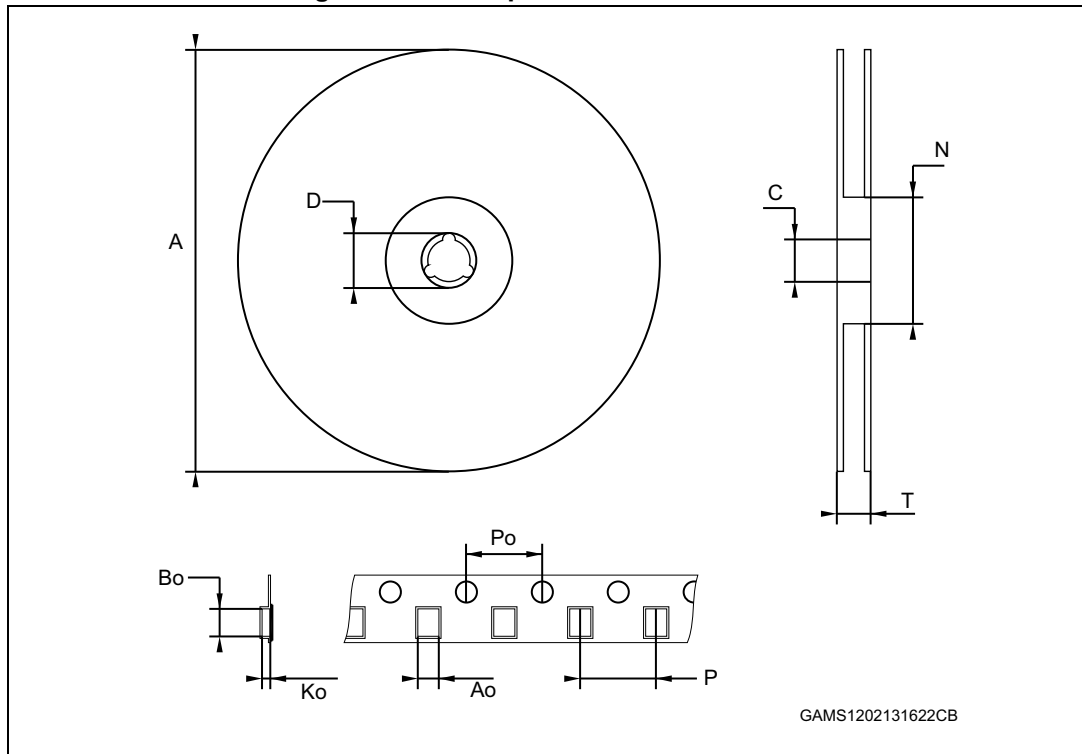

Table 9. SO14 package mechanical data

Ref	Dimensions					
	Millimeters			Inches		
	Min.	Typ.	Max.	Min.	Typ.	Max.
A			1.75			0.068
a1	0.1		0.2	0.003		0.007
a2			1.65			0.064
b	0.35		0.46	0.013		0.018
b1	0.19		0.25	0.007		0.010
C		0.5			0.019	
c1		45 °			45 °	
D	8.55		8.75	0.336		0.344
E	5.8		6.2	0.228		0.244
e		1.27			0.050	
e3		7.62			0.300	
F	3.8		4.0	0.149		0.157
G	4.6		5.3	0.181		0.208
L	0.5		1.27	0.019		0.050
M			0.68			0.026
S			8 °			8 °

Figure 6. SO14 tape and reel information



1. Drawing is not to scale

Table 10. SO14 tape and reel information

Ref	Dimensions			
	Millimeters		Inches	
	Min.	Max.	Min.	Max.
A		330		12.992
C	12.8	13.2	0.504	0.519
D	20.2		0.795	
N	60		2.362	
T		22.4		0.882
Ao	6.4	6.6	0.252	0.260
Bo	9	9.2	0.354	0.362
Ko	2.1	2.3	0.082	0.090
Po	3.9	4.1	0.153	0.161
P	7.9	8.1	0.311	0.319

4.2 TSSOP14 package information

Figure 7. TSSOP14 package mechanical drawing

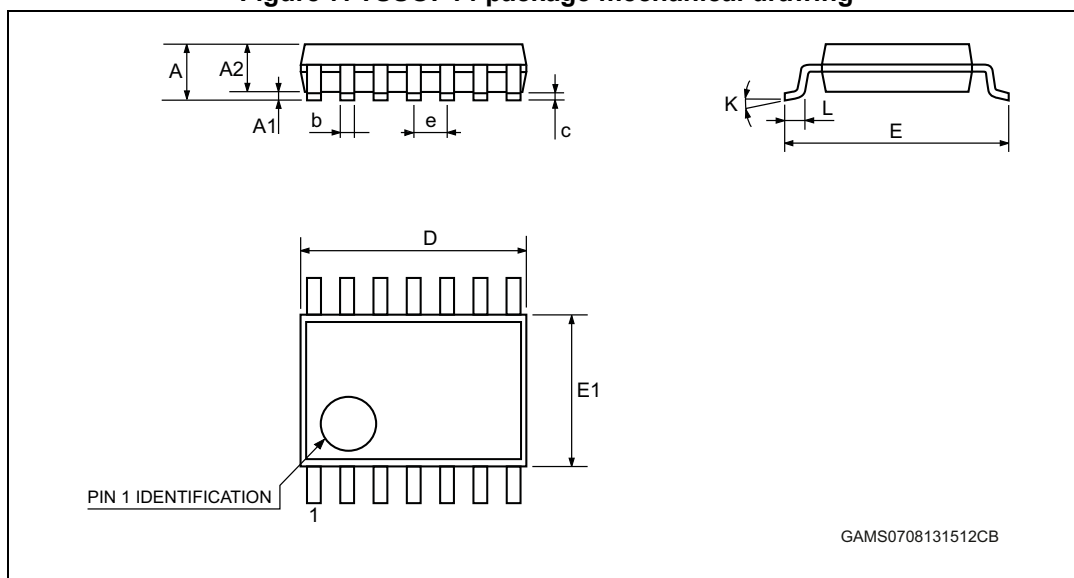
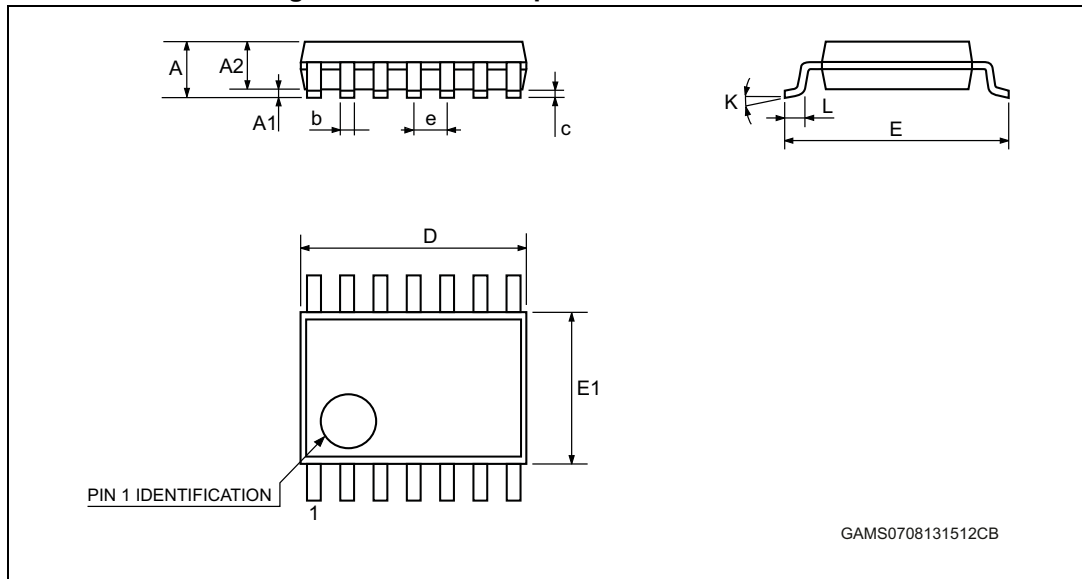

Table 11. TSSOP14 package mechanical data

Ref	Dimensions					
	Millimeters			Inches		
	Min.	Typ.	Max.	Min.	Typ.	Max.
A			1.2			0.047
A1	0.05		0.15	0.002	0.004	0.006
A2	0.8	1	1.05	0.031	0.039	0.041
b	0.19		0.30	0.007		0.012
c	0.09		0.20	0.004		0.0089
D	4.9	5	5.1	0.193	0.197	0.201
E	6.2	6.4	6.6	0.244	0.252	0.260
E1	4.3	4.4	4.48	0.169	0.173	0.176
e		0.65			0.0256	
K	0°		8°	0°		8°
L	0.45	0.60	0.75	0.018	0.024	0.030

Figure 8. TSSOP14 tape and reel information



1. Drawing is not to scale

Table 12. TSSOP14 tape and reel information

Ref	Dimensions			
	Millimeters		Inches	
	Min.	Max.	Min.	Max.
A		330		12.992
C	12.8	13.2	0.504	0.519
D	20.2		0.795	
N	60		2.362	
T		22.4		0.882
Ao	6.7	6.9	0.264	0.272
Bo	5.3	5.5	0.209	0.217
Ko	1.6	1.8	0.063	0.071
Po	3.9	4.1	0.153	0.161
P	7.9	8.1	0.311	0.319

5 Ordering information

Table 13. Order codes

Order code	Temperature range	Package	Packing	Marking
M74HC14RM13TR	-55 °C to +125 °C	S014	Tape and reel	74HC14
M74HC14YRM13TR ⁽¹⁾	-40 °C to +125 °C	SO14 (automotive grade)		74HC14Y
M74HC14TTR	-55 °C to +125 °C	TSSOP14		HC14
M74HC14YTTR ⁽¹⁾	-40 °C to +125 °C	TSSOP14 (automotive grade)		HC14Y

1. Qualification and characterization according to AEC Q100 and Q003 or equivalent, advanced screening according to AEC Q001 and Q002.

6 Revision history

Table 14. Document revision history

Date	Revision	Changes
01-Jul-2001	1	Initial release.
23-May-2008	2	Document converted and restructured to new template. Removed: M74HC14M1R order code. Added: tape and reel specifications for SO-14 and TSSOP14 packages.
09-Aug-2013	3	<i>Features</i> : added ESD information <i>Table 1: Device summary</i> : added automotive grade order codes. Added <i>Section 5: Ordering information</i> .
13-Jan-2014	4	Removed DIP14 package <i>Table 1: Device summary</i> and <i>Table 13: Order codes</i> : added "Temperature range" and "Marking"; updated 1.

Please Read Carefully:

Information in this document is provided solely in connection with ST products. STMicroelectronics NV and its subsidiaries ("ST") reserve the right to make changes, corrections, modifications or improvements, to this document, and the products and services described herein at any time, without notice.

All ST products are sold pursuant to ST's terms and conditions of sale.

Purchasers are solely responsible for the choice, selection and use of the ST products and services described herein, and ST assumes no liability whatsoever relating to the choice, selection or use of the ST products and services described herein.

No license, express or implied, by estoppel or otherwise, to any intellectual property rights is granted under this document. If any part of this document refers to any third party products or services it shall not be deemed a license grant by ST for the use of such third party products or services, or any intellectual property contained therein or considered as a warranty covering the use in any manner whatsoever of such third party products or services or any intellectual property contained therein.

UNLESS OTHERWISE SET FORTH IN ST'S TERMS AND CONDITIONS OF SALE ST DISCLAIMS ANY EXPRESS OR IMPLIED WARRANTY WITH RESPECT TO THE USE AND/OR SALE OF ST PRODUCTS INCLUDING WITHOUT LIMITATION IMPLIED WARRANTIES OF MERCHANTABILITY, FITNESS FOR A PARTICULAR PURPOSE (AND THEIR EQUIVALENTS UNDER THE LAWS OF ANY JURISDICTION), OR INFRINGEMENT OF ANY PATENT, COPYRIGHT OR OTHER INTELLECTUAL PROPERTY RIGHT.

ST PRODUCTS ARE NOT DESIGNED OR AUTHORIZED FOR USE IN: (A) SAFETY CRITICAL APPLICATIONS SUCH AS LIFE SUPPORTING, ACTIVE IMPLANTED DEVICES OR SYSTEMS WITH PRODUCT FUNCTIONAL SAFETY REQUIREMENTS; (B) AERONAUTIC APPLICATIONS; (C) AUTOMOTIVE APPLICATIONS OR ENVIRONMENTS, AND/OR (D) AEROSPACE APPLICATIONS OR ENVIRONMENTS. WHERE ST PRODUCTS ARE NOT DESIGNED FOR SUCH USE, THE PURCHASER SHALL USE PRODUCTS AT PURCHASER'S SOLE RISK, EVEN IF ST HAS BEEN INFORMED IN WRITING OF SUCH USAGE, UNLESS A PRODUCT IS EXPRESSLY DESIGNATED BY ST AS BEING INTENDED FOR "AUTOMOTIVE, AUTOMOTIVE SAFETY OR MEDICAL" INDUSTRY DOMAINS ACCORDING TO ST PRODUCT DESIGN SPECIFICATIONS. PRODUCTS FORMALLY ESCC, QML OR JAN QUALIFIED ARE DEEMED SUITABLE FOR USE IN AEROSPACE BY THE CORRESPONDING GOVERNMENTAL AGENCY.

Resale of ST products with provisions different from the statements and/or technical features set forth in this document shall immediately void any warranty granted by ST for the ST product or service described herein and shall not create or extend in any manner whatsoever, any liability of ST.

ST and the ST logo are trademarks or registered trademarks of ST in various countries.

Information in this document supersedes and replaces all information previously supplied.

The ST logo is a registered trademark of STMicroelectronics. All other names are the property of their respective owners.

© 2014 STMicroelectronics - All rights reserved

STMicroelectronics group of companies

Australia - Belgium - Brazil - Canada - China - Czech Republic - Finland - France - Germany - Hong Kong - India - Israel - Italy - Japan - Malaysia - Malta - Morocco - Philippines - Singapore - Spain - Sweden - Switzerland - United Kingdom - United States of America

www.st.com

