

FEATURES

- **complete linear system**
- **current mode class H output stage**
- **current drive power amp**
- **low distortion / low noise**
- **low amplifier current 190 μ A typical**
- **small size for CIC applications**

STANDARD PACKAGING

- Hybrid Typical Dimensions (0.180in x 0.075in x 0.055in)
(4.57mm x 1.91mm x 1.40mm)
- Hybrid View

DESCRIPTION

The GS3034 hybrid offers Gennum's new innovative class H output stage along with two low noise inverting preamplifiers, in a CIC size package.

This new breed of output stage adapts the bias current of the receiver to the user's listening environment. In relatively loud environments the receiver will be fully biased similar to a traditional class A amplifier. However, as the loudness of the environment decreases, the bias current of the receiver adjusts to a minimum level required to cleanly pass the signal. At the same time the system maintains adequate "headroom" should the amplitude of the signal suddenly increase. By adapting the bias of the output stage to the requirements of the signal being processed, significant current savings can be realized compared to traditional class A amplifiers.

The rate at which the bias adapts is associated with a capacitor connected from pad CC of the hybrid to ground. For optimum performance it is recommended that a 0.22 μ F capacitor be used.

The two low noise preamplifiers Stage A and Stage B, can be used as Volume Control and Gain Trim elements or Stage A as a filter shaping element and Stage B as the Volume Control. As the output stage is current drive, frequency shaping is relatively easy via the addition of a capacitor across the receiver.

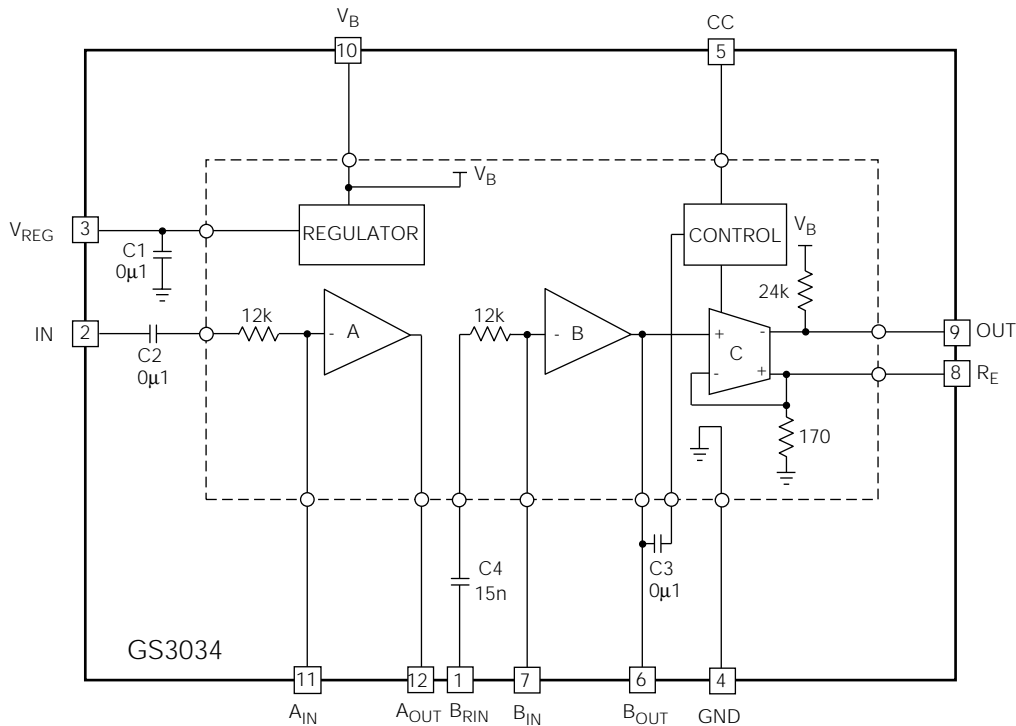

All resistors in ohms, all capacitors in farads unless otherwise stated.

FUNCTIONAL BLOCK DIAGRAM

ABSOLUTE MAXIMUM RATINGS

PARAMETER	VALUE / UNITS
Supply Voltage	5 VDC
Power Dissipation	25 mW
Operating Temperature Range	-10° C to 40° C
Storage Temperature Range	-20° C to 70° C

CAUTION
CLASS 1 ESD SENSITIVITY



PAD CONNECTION

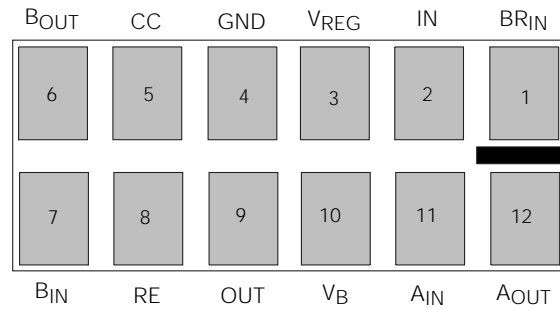

ELECTRICAL CHARACTERISTICS

Conditions: Frequency = 5 kHz, Temperature 25 °C, Voltage Supply = 1.3 VDC

PARAMETER	SYMBOL	CONDITIONS	MIN	TYP	MAX	UNITS
OVERALL						
Amplifier Current	I_{AMP}		80	190	300	μA
Minimum Operating Voltage	V_B		-	-	1.1	V
Overall Gain	A_V		44	47	50	dB
Distortion	THD	$V_{IN} = -40$ dBV $R_{GT} = R_{VC} = 10$ k Ω	-	0.2	1	%
Input Referred Noise	IRN	A Weighted Filter	-	-	2.5	μV_{RMS}
VOLTAGE REGULATOR						
Regulator Voltage	V_{REG}	$I_{LOAD} = 30$ μA	870	920	970	mVDC
Output Noise		A Weighted Filter	-	2.9	-	μV_{RMS}
STAGE A and STAGE B						
Input Bias Current	I_{BIAS}	$R_{VC} = R_{GT} = 1$ M Ω	-25	0	25	nA
DC Voltage Gain	Stage A	A_{OL-A}	38	52	-	dB
	Stage B	A_{OL-B}	30	40	-	dB
Current Source Capabilities	I_{SOURCE}		15	30	-	μA
Output Voltage Swing - Low	V_{SINK}		200	280	-	mV
STAGE C & CONTROL CIRCUIT						
Maximum Current Sinking	I_{SINK}	R_E grounded, $V_{OUT} = 1.3$ V	3	6	-	mA
Output Impedance	R_{OUT}		20	24	-	k Ω
Minimum Emitter Voltage	V_{RE-MIN}		2	5	9	mV
Maximum Emitter Voltage	V_{RE-MAX}		68	73	80	mV
Minimum Transducer Current	I_{T-MIN}		2	20	50	μA
Maximum Transducer Current	I_{T-MAX}		300	400	500	μA
Maximum/Minimum Transducer Current Ratio	I_{RANGE}		15	28	-	dB
Dynamic Headroom	Headroom	Note 1	14	17	22	dB
Time Constant	T_C	$C_{CC} = 0.22$ μF	-	130	-	mS

All parameters and switches remain as shown in the Test Circuit unless otherwise stated in CONDITIONS column.

Notes: 1. Headroom = $20 \text{ Log} (V_{RE-DC} / V_{RE-ACRMS})$ [$V_{IN} = -79$ dBV]

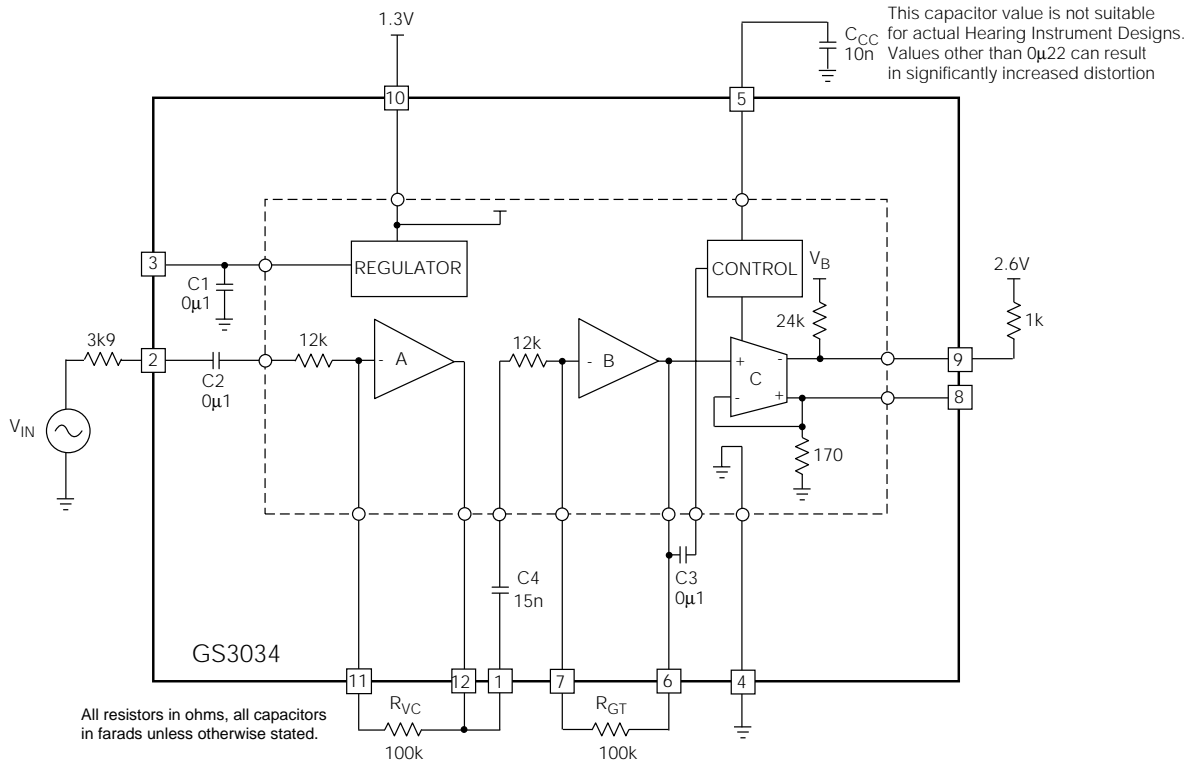

Fig. 1 Production Test Circuit

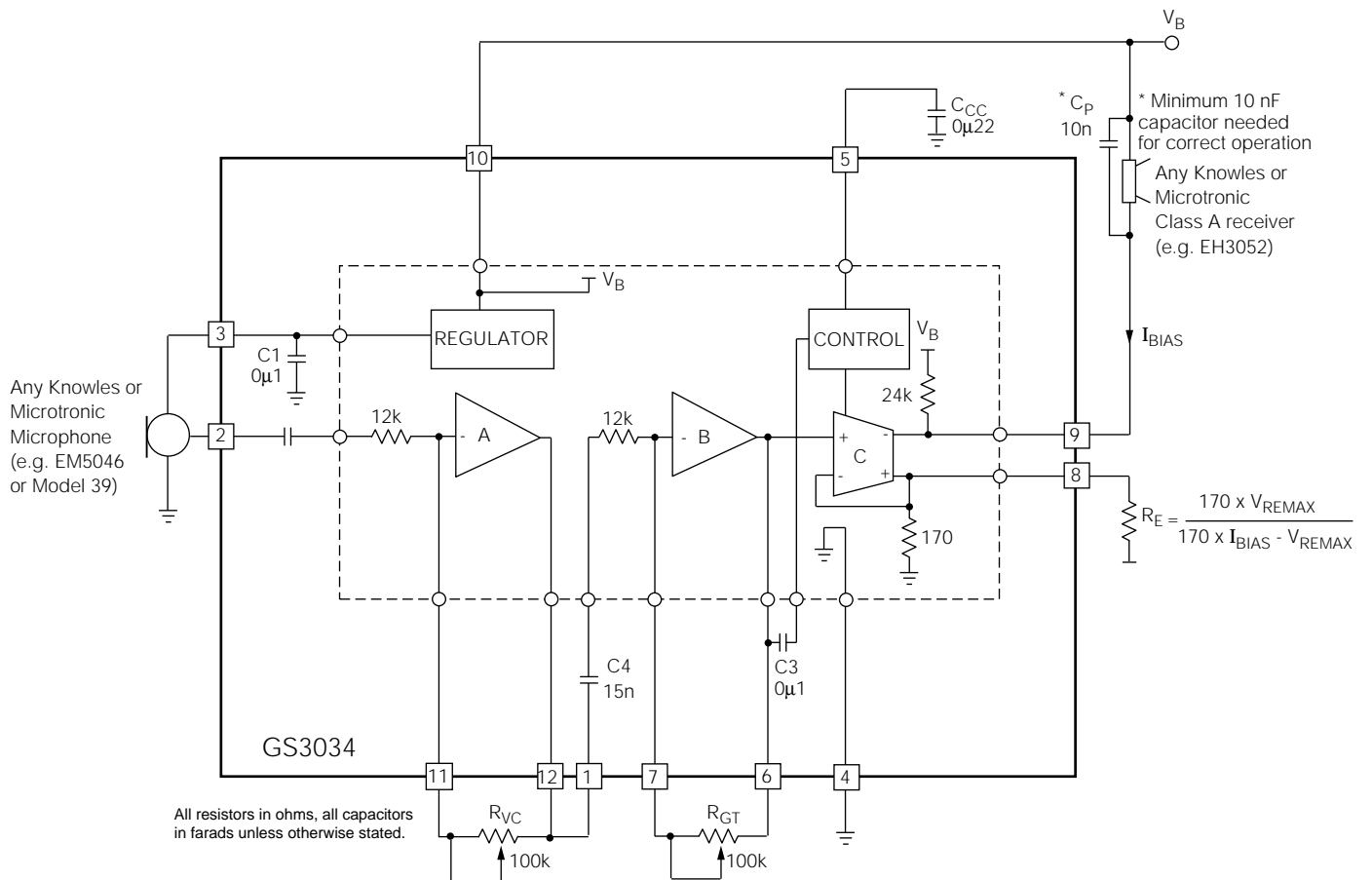

Fig. 2 Typical Hearing Instrument Application

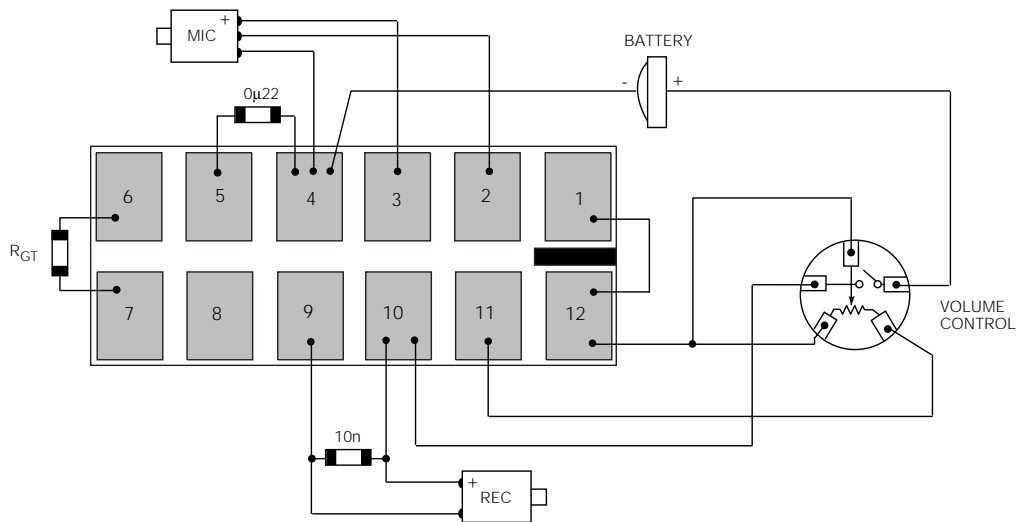

Fig. 3 Typical Assembly Diagram

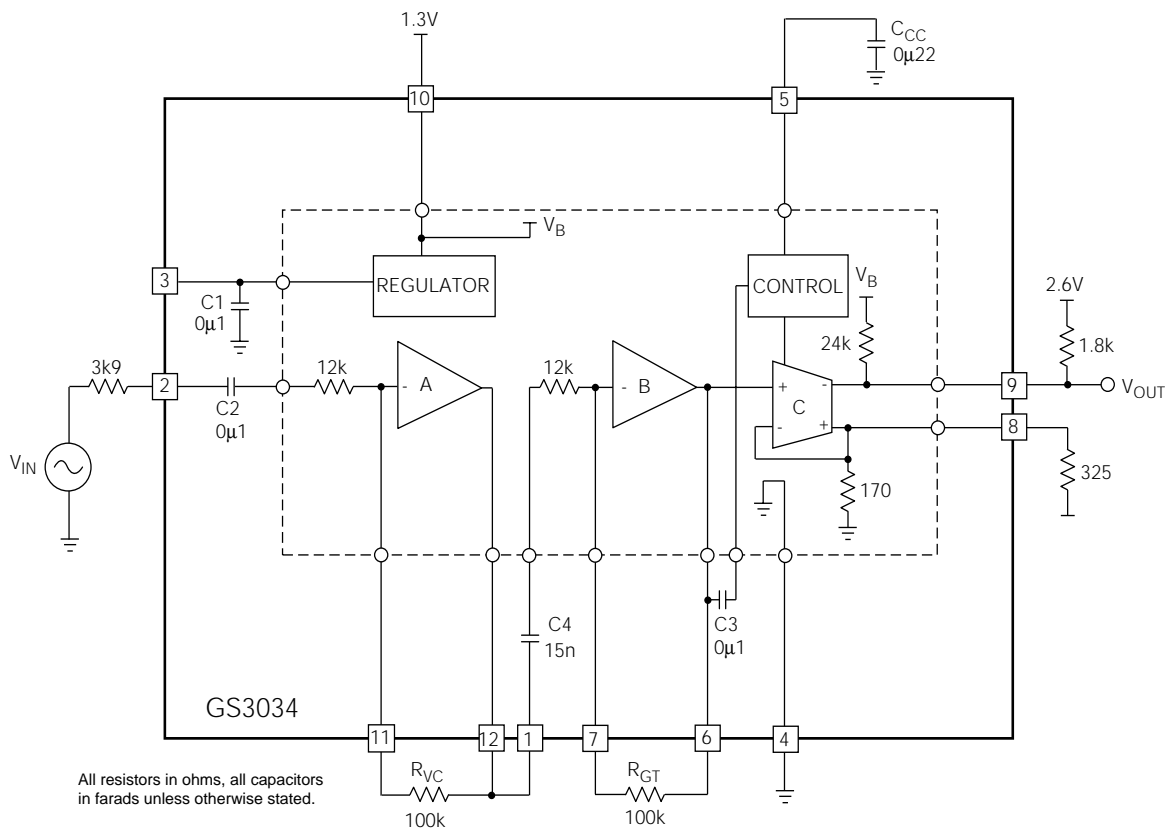

Fig. 4 Characterization Circuit

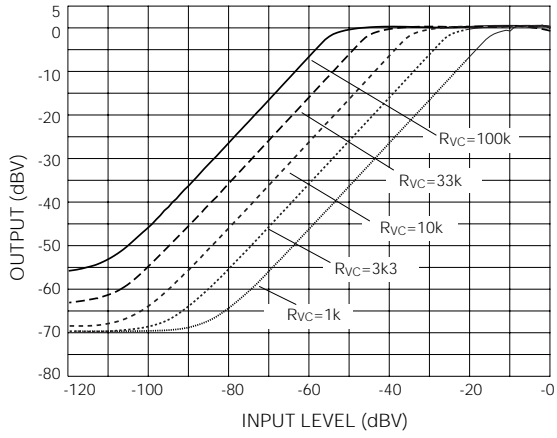

Fig. 5 Input vs Output

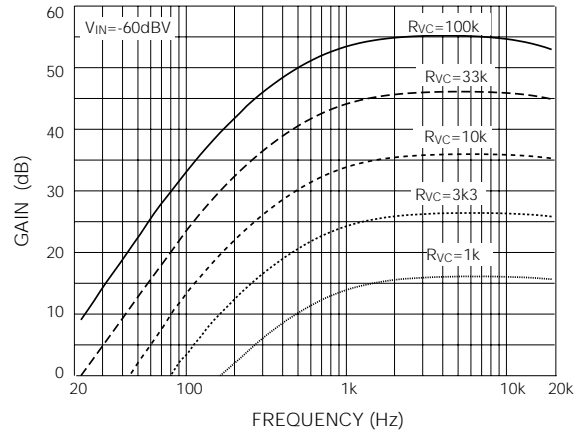

Fig. 6 Gain vs Frequency

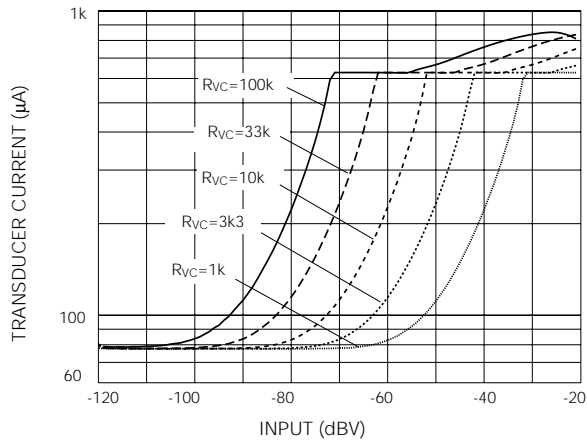

Fig. 7 Transducer Current vs Input

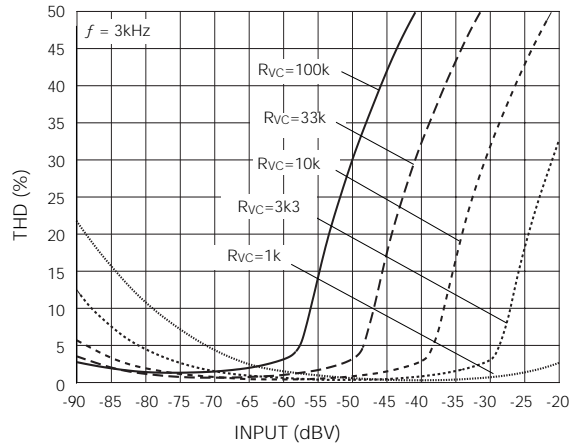

Fig. 8 Distortion vs Input

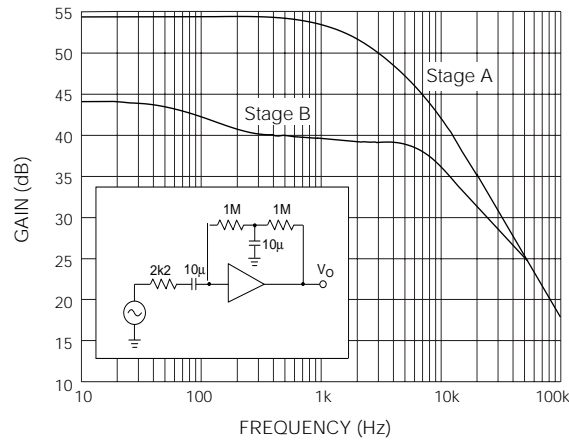
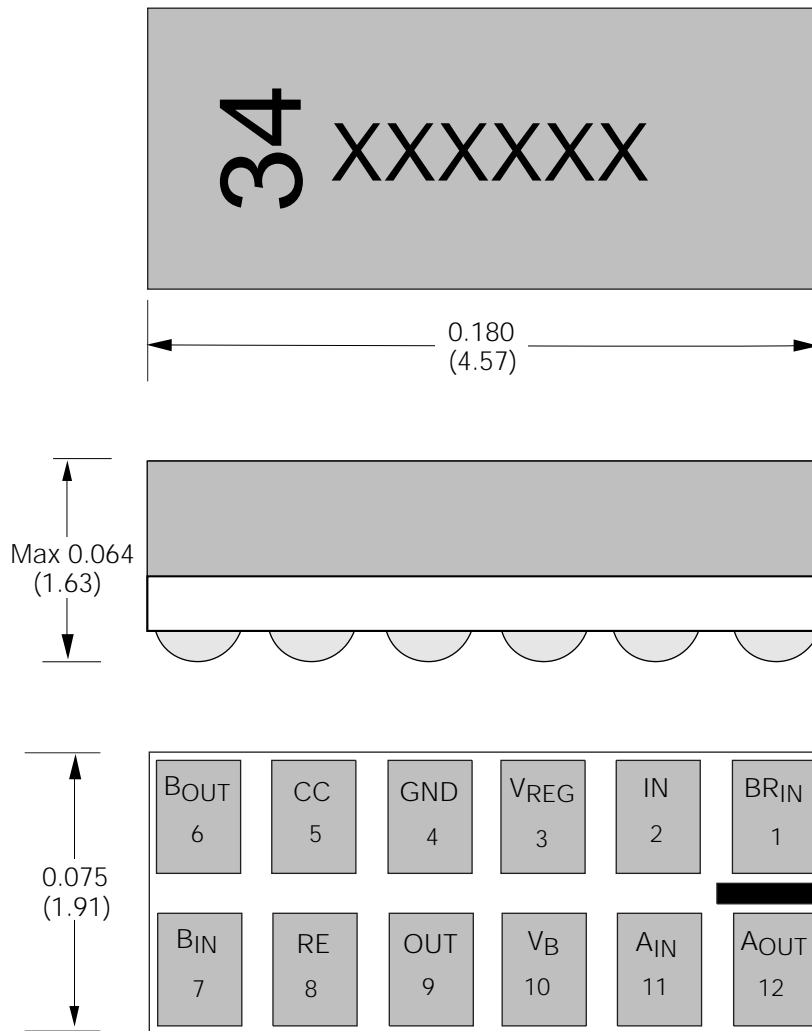

Fig. 9 Stage A and Stage B Open Loop Gain



Dimension units are in inches.
 Dimensions in parenthesis are in millimetres converted from inches and include minor rounding errors.
 1.0000 inches = 25.400 mm.
 Pad sizes 0.021 x 0.029 (0.53 x 0.74).
 Dimension tolerances: ± 0.003 (+0.08) unless otherwise stated.
 Pad numbers for illustration only.
 XXXXXX - work order number.
 This hybrid is designed to be reflowable for Gennum's reflow process profile.
 For more information contact Gennum Corporation.

Fig. 10 Hybrid Layout & Dimensions

GENNUM CORPORATION

MAILING ADDRESS:
 P.O. Box 489, Stn. A, Burlington, Ontario, Canada L7R 3Y3
 Tel. +1 (905) 632-2996 Fax +1 (905) 632-2814
 SHIPPING ADDRESS:
 970 Fraser Drive, Burlington, Ontario, Canada L7L 5P5

GENNUM JAPAN CORPORATION

C-101, Miyamae Village, 2-10-42 Miyamae, Suginami-ku, Tokyo 168-0081,
 Japan Tel. +81 (3) 3334-7700 Fax: +81 (3) 3247-8839

DOCUMENT IDENTIFICATION: DATA SHEET
 The product is in production. Gennum reserves the right to make changes at any time to improve reliability, function or design, in order to provide the best product possible.

REVISION NOTES:
 Correction to Typical Assembly Diagram.

Gennum Corporation assumes no responsibility for the use of any circuits described herein and makes no representations that they are free from patent infringement.

© Copyright January 1996 Gennum Corporation. All rights reserved. Printed in Canada.