



### FEATURES

- Biopotential signals in; digitized signals out
- 5 acquisition (ECG) channels and one driven lead
- Parallel ICs for up to 10+ electrode measurements
  - Master [ADAS1000](#) or [ADAS1000-1](#) used with Slave [ADAS1000-2](#)
- AC and DC lead-off detection
- Internal pace detection algorithm on 3 leads
  - Support for user's own pace
- Thoracic impedance measurement (internal/external path)
- Selectable reference lead
- Scalable noise vs. power control, power-down modes
- Low power operation from
  - 11 mW (1 lead), 15 mW (3 leads), 21 mW (all electrodes)
- Lead or electrode data available
- Supports AAMI EC11:1991/(R)2001/(R)2007, AAMI EC38 R2007, EC13:2002/(R)2007, IEC60601-1 ed. 3.0 b:2005, IEC60601-2-25 ed. 2.0 :2011, IEC60601-2-27 ed. 2.0 b:2005, IEC60601-2-51 ed. 1.0 b: 2005
- Fast overload recovery
- Low or high speed data output rates
- Serial interface SPI-/QSPI™-/DSP-compatible
- 56-lead LFCSP package (9 mm × 9 mm)
- 64-lead LQFP package (10 mm × 10 mm body size)

### APPLICATIONS

- ECG: monitor and diagnostic
  - Bedside patient monitoring, portable telemetry, Holter, AED, cardiac defibrillators, ambulatory monitors, pace maker programmer, patient transport, stress testing

### GENERAL DESCRIPTION

The [ADAS1000/ADAS1000-1/ADAS1000-2](#) measure electrocardiac (ECG) signals, thoracic impedance, pacing artifacts, and lead-on/off status and output this information in the form of a data frame supplying either lead/vector or electrode data at programmable data rates. Its low power and small size make it suitable for portable, battery-powered applications. The high performance also makes it suitable for higher end diagnostic machines.

The [ADAS1000](#) is a full-featured, 5-channel ECG including respiration and pace detection, while the [ADAS1000-1](#) offers only ECG channels with no respiration or pace features. Similarly, the [ADAS1000-2](#) is a subset of the main device and is configured for gang purposes with only the ECG channels enabled (no respiration, pace, or right leg drive).

The [ADAS1000/ADAS1000-1/ADAS1000-2](#) are designed to simplify the task of acquiring and ensuring quality ECG signals. They provide a low power, small data acquisition system for biopotential applications. Auxiliary features that aid in better quality ECG signal acquisition include: multichannel averaged driven lead, selectable reference drive, fast overload recovery, flexible respiration circuitry returning magnitude and phase information, internal pace detection algorithm operating on three leads, and the option of ac or dc lead-off detection. Several digital output options ensure flexibility when monitoring and analyzing signals. Value-added cardiac post processing is executed externally on a DSP, microprocessor, or FPGA.

Because ECG systems span different applications, the [ADAS1000/ADAS1000-1/ADAS1000-2](#) feature a power/noise scaling architecture where the noise can be reduced at the expense of increasing power consumption. Signal acquisition channels may be shut down to save power. Data rates can be reduced to save power.

To ease manufacturing tests and development as well as offer holistic power-up testing, the [ADAS1000/ADAS1000-1/ADAS1000-2](#) offer a suite of features, such as dc and ac test excitation via the calibration DAC and CRC redundancy testing in addition to readback of all relevant register address space.

The input structure is a differential amplifier input thereby allowing users a variety of configuration options to best suit their application.

The [ADAS1000/ADAS1000-1/ADAS1000-2](#) are available in two package options: either a 56-lead LFCSP or a 64-lead LQFP package; they are specified over -40°C to +85°C temperature range.

**TABLE OF CONTENTS**

Features .....	1	Extend Switch On Respiration Paths .....	39
Applications .....	1	Pacing Artifact Detection Function (ADAS1000 Only) .....	40
General Description .....	1	Biventricular Pacers .....	42
Revision History .....	2	Pace Detection Measurements .....	42
Functional Block Diagram .....	3	Evaluating Pace Detection Performance .....	43
Specifications .....	4	Pace Latency .....	43
Noise Performance .....	9	Pace Detection via Secondary Serial Interface (ADAS1000 and ADAS1000-1 Only) .....	43
Timing Characteristics .....	10	Filtering .....	43
Absolute Maximum Ratings .....	13	Voltage Reference .....	45
Thermal Resistance .....	13	Gang Mode Operation .....	45
ESD Caution .....	13	Interfacing in Gang Mode .....	47
Pin Configurations and Function Descriptions .....	14	Serial Interfaces .....	48
Typical Performance Characteristics .....	18	Standard Serial Interface .....	48
Applications Information .....	25	Secondary Serial Interface .....	52
Overview .....	25	RESET .....	52
ECG Inputs—Electrodes/Leads .....	28	PD Function .....	52
ECG Channel .....	29	SPI Output Frame Structure (ECG and Status Data) .....	53
Electrode/Lead Formation and Input Stage Configuration ..	30	SPI Register Definitions and Memory Map .....	54
Defibrillator Protection .....	33	Control Registers Details .....	55
ESIS Filtering .....	33	Examples of Interfacing to the ADAS1000 .....	72
ECG Path Input Multiplexing .....	33	Software Flowchart .....	75
Common-Mode Selection and Averaging .....	34	Power Supply, Grounding, and Decoupling Strategy .....	76
Wilson Central Terminal (WCT) .....	35	AVDD .....	76
Right Leg Drive/Reference Drive .....	35	ADCVDD and DVDD Supplies .....	76
Calibration DAC .....	36	Unused Pins/Paths .....	76
Gain Calibration .....	36	Layout Recommendations .....	76
Lead-Off Detection .....	36	Outline Dimensions .....	77
Shield Driver .....	36	Ordering Guide .....	78
Respiration (ADAS1000 Model Only) .....	37		
Evaluating Respiration Performance .....	39		

**REVISION HISTORY**

**1/13—Rev. 0 to Rev. A**

Changes to Features Section .....	1
Changes to Table 1 .....	3
Changes to Excitation Current, Test Conditions/Comments, Table 2 .....	5
Added Table 3; Renumbered Sequentially .....	9
Changes to Respiration (ADAS1000 Model Only) Section, Figure 66, and Internal Respiration Capacitors Section .....	37
Changes to Figure 67 .....	38

Changes to Figure 68 .....	39
Added Evaluating Pace Detection Performance Section .....	43
Added Table 15 .....	47
Changes to Clocks Section .....	51
Changes to RESPAMP Name, Function, Table 28 .....	57
Changes to Bits[14:9], Function, Table 30 .....	59
Changes to Ordering Guide .....	78

**8/12—Revision 0: Initial Version**

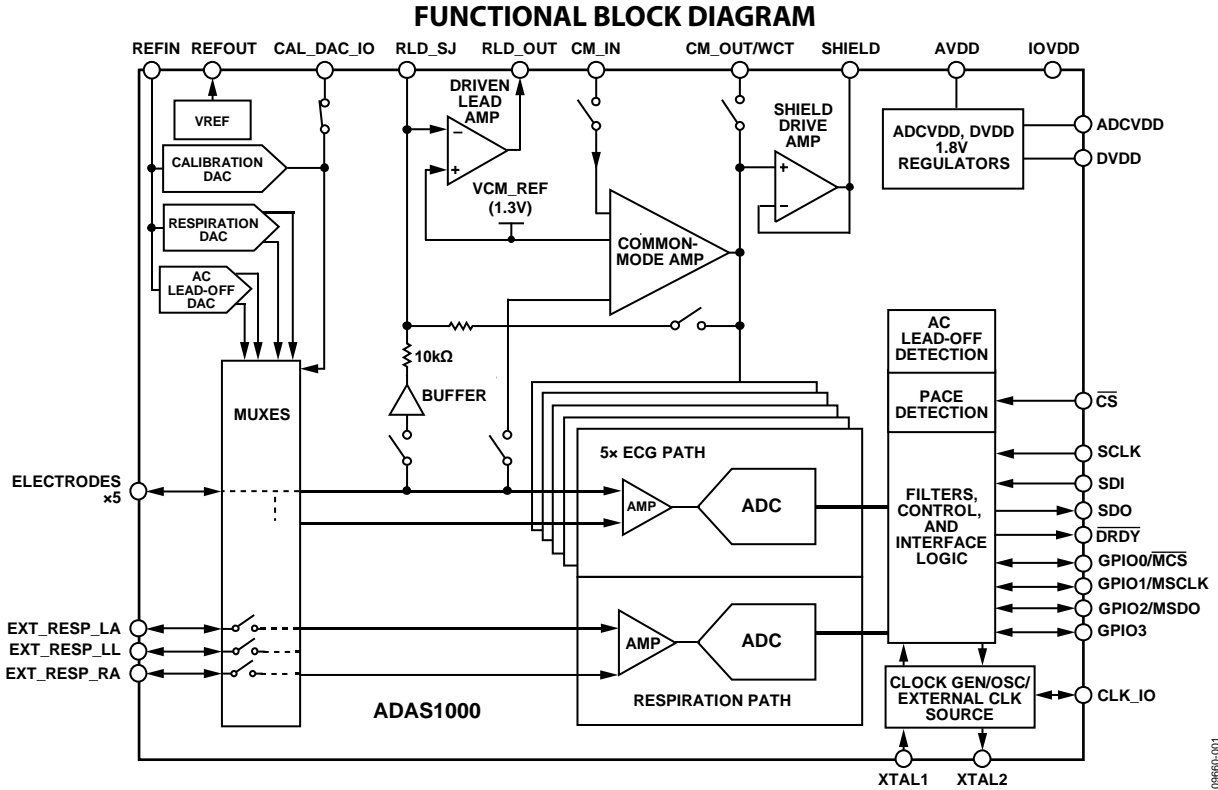

Figure 1. ADAS1000 Full Featured Model

Table 1. Overview of Features Available from ADAS1000 Generics

Generic	ECG	Operation	Right Leg Drive	Respiration	Pace Detection	Shield Driver	Master Interface <sup>1</sup>	Package Option
ADAS1000	5 ECG channels	Master/slave	Yes		Yes	Yes	Yes	LFCSP, LQFP
ADAS1000-1	5 ECG channels	Master/slave	Yes			Yes	Yes	LFCSP
ADAS1000-2 <sup>2</sup>	5 ECG channels	Slave						LFCSP, LQFP
ADAS1000-3	3 ECG channels	Master/slave	Yes			Yes	Yes	LFCSP, LQFP
ADAS1000-4	3 ECG channels	Master/slave	Yes	Yes	Yes	Yes	Yes	LFCSP, LQFP

<sup>1</sup> Master interface is provided for users wishing to utilize their own digital pace algorithm; see the Secondary Serial Interface section.

<sup>2</sup> This is a companion device for increased channel count purposes. It has a subset of features and is not intended for standalone use. It may be used in conjunction with any master device.

**SPECIFICATIONS**

AVDD = 3.3 V ± 5%, IOVDD = 1.65 V to 3.6 V, AGND = DGND = 0 V, REFIN tied to REFOUT, externally supplied crystal/clock = 8.192 MHz. Decoupling for reference and supplies as noted in the Power Supply, Grounding, and Decoupling Strategy section. T<sub>A</sub> = -40°C to +85°C, unless otherwise noted. Typical specifications are mean values at T<sub>A</sub> = 25°C.

For specified performance, internal ADCVDD and DVDD linear regulators have been used. They may be supplied from external regulators. ADCVDD = 1.8 V ± 5%, DVDD = 1.8 V ± 5%.

Front-end gain settings: GAIN 0 = ×1.4, GAIN 1 = ×2.1, GAIN 2 = ×2.8, GAIN 3 = ×4.2.

**Table 2.**

Parameter	Min	Typ	Max	Unit	Test Conditions/Comments
ECG CHANNEL					These specifications apply to the following pins: ECG1_LA, ECG2_LL, ECG3_RA, ECG4_V1, ECG5_V2, CM_IN (CE mode), EXT_RESP_xx pins when used in extend switch mode
Electrode Input Range	0.3	1.3	2.3	V	Independent of supply
	0.63	1.3	1.97	V	GAIN 0 (gain setting ×1.4)
	0.8	1.3	1.8	V	GAIN 1 (gain setting ×2.1)
	0.97	1.3	1.63	V	GAIN 2 (gain setting ×2.8)
Input Bias Current	-40	±1	+40	nA	Relates to each electrode input; over operating range; dc and ac lead-off are disabled
	-200		+200	nA	AGND to AVDD
Input Offset		-7		mV	Electrode/vector mode with VCM = VCM_REF
		-7		mV	GAIN 3
		-15		mV	GAIN 2
		-22		mV	GAIN 1
Input Offset Tempco <sup>1</sup>		±2		µV/°C	GAIN 0
Input Amplifier Input Impedance <sup>2</sup>		1  10		GΩ  pF	At 10 Hz
CMRR <sup>2</sup>	105	110		dB	51 kΩ imbalance, 60 Hz with ±300 mV differential dc offset; per AAMI/IEC standards; with driven leg loop closed
Crosstalk <sup>1</sup>		80		dB	Between channels
Resolution <sup>2</sup>		19		Bits	Electrode/vector mode, 2 kHz data rate, 24-bit data-word
		18		Bits	Electrode/vector mode, 16 kHz data rate, 24-bit data-word
		16		Bits	Electrode/analog lead mode, 128 kHz data rate, 16-bit data-word
Integral Nonlinearity Error		30		ppm	GAIN 0; all data rates
Differential Nonlinearity Error		5		ppm	GAIN 0
Gain <sup>2</sup>					Referred to input. (2 × VREF)/Gain/(2 <sup>N</sup> - 1). Applies after factory calibration. User calibration adjusts this number.
GAIN 0 (×1.4)		4.9		µV/LSB	At 19-bit level in 2 kHz data rate
		9.81		µV/LSB	At 18-bit level in 16 kHz data rate
GAIN 1 (×2.1)		39.24		µV/LSB	At 16-bit level in 128 kHz data rate
		3.27		µV/LSB	At 19-bit level in 2 kHz data rate
		6.54		µV/LSB	At 18-bit level in 16 kHz data rate
GAIN 2 (×2.8)		26.15		µV/LSB	At 16-bit level in 128 kHz data rate
		2.45		µV/LSB	At 19-bit level in 2 kHz data rate
		4.9		µV/LSB	At 18-bit level in 16 kHz data rate
GAIN 3 (×4.2)		19.62		µV/LSB	At 16-bit level in 128 kHz data rate
		1.63		µV/LSB	No factory calibration for this gain setting
		3.27		µV/LSB	At 19-bit level in 2 kHz data rate
		13.08		µV/LSB	At 18-bit level in 16 kHz data rate
				µV/LSB	At 16-bit level in 128 kHz data rate

Parameter	Min	Typ	Max	Unit	Test Conditions/Comments
Gain Error	-1	+0.01	+1	%	GAIN 0 to GAIN 2, factory calibrated. Programmable user or factory calibration option enables. Factory gain calibration applies only to standard ECG interface.
Gain Matching	-2	+0.1	+2	%	GAIN 3 setting, no factory calibration for this gain
Gain Tempco <sup>1</sup>		25		ppm/°C	GAIN 0 to GAIN 2
Input Referred Noise <sup>1</sup>					GAIN 3
Analog Lead Mode		6		μV p-p	GAIN 2, 2 kHz data rate, see Table 4
Electrode Mode		10		μV p-p	0.5 Hz to 40 Hz; high performance mode
Digital Lead Mode		12		μV p-p	0.05 Hz to 150 Hz; high performance mode
Power Supply Sensitivity <sup>2</sup>		11		μV p-p	0.05 Hz to 150 Hz; low power mode
Analog Channel Bandwidth <sup>1</sup>		12		μV p-p	0.05 Hz to 150 Hz; high performance mode
Dynamic Range <sup>1</sup>		14		μV p-p	0.05 Hz to 150 Hz; low power mode
Signal-to-Noise Ratio <sup>1</sup>		16		μV p-p	0.05 Hz to 150 Hz; high performance mode
Power Supply Sensitivity <sup>2</sup>		100		dB	0.05 Hz to 150 Hz; low power mode
Analog Channel Bandwidth <sup>1</sup>		65		kHz	At 120 Hz
Dynamic Range <sup>1</sup>		104		dB	GAIN 0, 2 kHz data rate, -0.5 dBFS input signal, 10 Hz
Signal-to-Noise Ratio <sup>1</sup>		100		dB	-0.5 dB FS input signal
COMMON-MODE INPUT					CM_IN pin
Input Voltage Range	0.3		2.3	V	
Input Impedance <sup>2</sup>		1  10		GΩ  pF	
Input Bias Current	-40	±1	+40	nA	Over operating range; dc and ac lead-off disabled
	-200		+200	nA	AGND to AVDD
COMMON-MODE OUTPUT					CM_OUT pin
VCM_REF	1.28	1.3	1.32	V	Internal voltage; independent of supply
Output Voltage, VCM	0.3	1.3	2.3	V	No dc load
Output Impedance <sup>1</sup>		0.75		kΩ	Not intended to drive current
Short Circuit Current <sup>1</sup>		4		mA	
Electrode Summation Weighting Error <sup>2</sup>		1		%	Resistor matching error
RESPIRATION FUNCTION (ADAS1000 ONLY)					These specifications apply to the following pins: EXT_RESP_LA, EXT_RESP_LL, EXT_RESP_RA and selected internal respiration paths (Lead I, Lead II, Lead III)
Input Voltage Range	0.3		2.3	V	AC-coupled, independent of supply
Input Voltage Range (Linear Operation)		1.8/gain		V p-p	Programmable gain (10 states)
Input Bias Current	-10	±1	+10	nA	Applies to EXT_RESP_xx pins over AGND to AVDD
Input Referred Noise <sup>1</sup>		0.85		μV rms	
Frequency <sup>2</sup>		46.5 to 64		kHz	Programmable frequency, see Table 28
Excitation Current		64		μA p-p	Respiration drive current corresponding to differential voltage programmed by RESPAMP bits in RESPCTL register. Internal respiration mode, cable 5 kΩ/200 pF, 1.2 kΩ chest impedance
Resolution <sup>2</sup>		32		μA p-p	Drive Range A
Measurement Resolution <sup>1</sup>		16		μA p-p	Drive Range B <sup>2</sup>
		8		μA p-p	Drive Range C <sup>2</sup>
		24		μA p-p	Drive Range D <sup>2</sup>
		0.2		bits	Update rate 125 Hz
		0.02		Ω	Cable <5 kΩ/200 pF per electrode, body resistance modeled as 1.2 kΩ
In-Amp Gain <sup>1</sup>		1 to 10		Ω	No cable impedance, body resistance modeled as 1.2 kΩ
Gain Error			1	%	Digitally programmable in steps of 1
Gain Tempco <sup>1</sup>		25		ppm/C	LSB weight for GAIN 0 setting

Parameter	Min	Typ	Max	Unit	Test Conditions/Comments
<b>RIGHT LEG DRIVE/DRIVEN LEAD (ADAS1000/ADAS1000-1 ONLY)</b>					
Output Voltage Range	0.2		AVDD – 0.2	V	External protection resistor required to meet regulatory patient current limits; output shorted to AVDD/AGND
RLD_OUT Short Circuit Current	–5	±2	+5	mA	
Closed-Loop Gain Range <sup>2</sup>	25			V/V	
Slew Rate <sup>2</sup>		200		mV/ms	
Input Referred Noise <sup>1</sup>		8		µV p-p	
Amplifier GBP <sup>2</sup>		1.5		MHz	
<b>DC LEAD-OFF</b>					
Lead-Off Current Accuracy		±10		%	Internal current source, pulls up open ECG pins; programmable in 10 nA steps: 10 nA to 70 nA Of programmed value Inputs are compared to threshold levels; if inputs exceed levels, lead-off flag is raised
High Threshold Level <sup>1</sup>		2.4		V	
Low Threshold Level <sup>1</sup>		0.2		V	
Threshold Accuracy		25		mV	
<b>AC LEAD-OFF</b>					
Frequency Range		2.031		kHz	Programmable in 4 steps: 12.5 nA rms, 25 nA rms, 50 nA rms, 100 nA rms Fixed frequency Of programmed value, measured into low impedance
Lead-Off Current Accuracy		±10		%	
<b>REFIN</b>					
Input Range <sup>2</sup>	1.76	1.8	1.84	V	Channel gain scales directly with REFIN Per active ADC 5 ECG channels and respiration enabled
Input Current	450	675	950	µA	
<b>REFOUT</b>					
Output Voltage, VREF	1.785	1.8	1.815	V	On-chip reference voltage for ADC; not intended to drive other components reference inputs directly, must be buffered externally  Short circuit to ground 0.05 Hz to 150 Hz (ECG band) 0.05 Hz to 5 Hz (respiration)
Reference Tempco <sup>1</sup>		±10		ppm/°C	
Output Impedance <sup>2</sup>		0.1		Ω	
Short Circuit Current <sup>1</sup>		4.5		mA	
Voltage Noise <sup>1</sup>		33		µV p-p	
		17		µV p-p	
<b>CALIBRATION DAC</b>					
DAC Resolution		10		Bits	Available on CAL_DAC_IO (output for master, input for slave) No load, nominal FS output is 1.5 × REFOUT No load
Full-Scale Output Voltage	2.64	2.7	2.76	V	
Zero-Scale Output Voltage	0.24	0.3	0.36	V	Not intended to drive low impedance load, used for slave CAL_DAC_IO configured as an input When used as input
DNL	–1		+1	LSB	
Output Series Resistance <sup>2</sup>		10		kΩ	
Input Current		±5		nA	
<b>CALIBRATION DAC TEST TONE</b>					
Output Voltage	0.9	1	1.1	mV p-p	Rides on common-mode voltage, VCM_REF = 1.3 V
Square Wave		1		Hz	
Low Frequency Sine Wave		10		Hz	
High Frequency Sine Wave		150		Hz	
<b>SHIELD DRIVER (ADAS1000/ ADAS1000-1 ONLY)</b>					
Output Voltage Range	0.3		2.3	V	Rides on common-mode voltage, VCM  Output current limited by internal series resistance
Gain		1		V/V	
Offset Voltage	–20		+20	mV	
Short Circuit Current		15	25	µA	
Stable Capacitive Load <sup>2</sup>			10	nF	
<b>CRYSTAL OSCILLATOR</b>					
Frequency <sup>2</sup>		8.192		MHz	Applied to XTAL1 and XTAL2
Start-Up Time <sup>2</sup>		15		ms	Internal startup

Parameter	Min	Typ	Max	Unit	Test Conditions/Comments
CLOCK_IO					External clock source supplied to CLK_IO; this pin is configured as an input when the device is programmed as a slave
Operating Frequency <sup>2</sup>		8.192		MHz	
Input Duty Cycle <sup>2</sup>	20		80	%	
Output Duty Cycle <sup>2</sup>		50		%	
DIGITAL INPUTS					Applies to all digital inputs
Input Low Voltage, V <sub>IL</sub>			0.3 × IOVDD	V	
Input High Voltage, V <sub>IH</sub>	0.7 × IOVDD			V	
Input Current, I <sub>IH</sub> , I <sub>IL</sub>	-1		+1	μA	
	-20		+20	μA	RESET has an internal pull-up
Pin Capacitance <sup>2</sup>		3		pF	
DIGITAL OUTPUTS					
Output Low Voltage, V <sub>OL</sub>			0.4	V	I <sub>SINK</sub> = 1 mA
Output High Voltage, V <sub>OH</sub>	IOVDD - 0.4			V	I <sub>SOURCE</sub> = -1 mA
Output Rise/Fall Time		4		ns	Capacitive load = 15 pF, 20% to 80%
DVDD REGULATOR					Internal 1.8 V regulator for DVDD
Output Voltage	1.75	1.8	1.85	V	
Available Current <sup>1</sup>		1		mA	Droop < 10 mV; for external device loading purposes
Short Circuit Current limit		40		mA	
ADCVDD REGULATOR					Internal 1.8 V regulator for ADCVDD; not recommended as a supply for other circuitry
Output Voltage	1.75	1.8	1.85	V	
Short Circuit Current Limit		40		mA	
POWER SUPPLY RANGES <sup>2</sup>					
AVDD	3.15	3.3	5.5	V	
IOVDD	1.65		3.6	V	
ADCVDD	1.71	1.8	1.89	V	If applied by external 1.8 V regulator
DVDD	1.71	1.8	1.89	V	If applied by external 1.8 V regulator
POWER SUPPLY CURRENTS					
AVDD Standby Current		785	975	μA	
IOVDD Standby Current		1	60	μA	
EXTERNALLY SUPPLIED ADCVDD AND DVDD					All 5 channels enabled, RLD enabled, pace enabled
AVDD Current		3.4	6.25	mA	High performance mode
		3.1	5.3	mA	Low performance mode
		4.25	6.3	mA	High performance mode, respiration enabled
ADCVDD Current		6.2	9	mA	High performance mode
		4.7	6.5	mA	Low performance mode
		7	9	mA	High performance mode, respiration enabled
DVDD Current		2.7	5	mA	High performance mode
		1.4	3.5	mA	Low performance mode
		3.4	5.5	mA	High performance mode, respiration enabled
INTERNALLY SUPPLIED ADCVDD AND DVDD					All 5 channels enabled, RLD enabled, pace enabled
AVDD Current		12.5	15.3	mA	High performance mode
		9.4	12.4	mA	Low performance mode
		14.8	17.3	mA	High performance mode, respiration enabled
POWER DISSIPATION					All 5 channels enabled, RLD enabled, pace enabled
Externally Supplied ADCVDD and DVDD <sup>3</sup>					
All 5 Input Channels and RLD		27		mW	High performance (low noise)
		21		mW	Low power mode
Internally Supplied ADCVDD and DVDD					All 5 channels enabled, RLD enabled, pace enabled
All 5 Input Channels and RLD		41		mW	High performance (low noise)
		31		mW	Low power mode

Parameter	Min	Typ	Max	Unit	Test Conditions/Comments
OTHER FUNCTIONS <sup>4</sup>					
Power Dissipation					
Respiration		7.6		mW	
Shield Driver		150		μW	

<sup>1</sup> Guaranteed by characterization, not production tested.

<sup>2</sup> Guaranteed by design, not production tested.

<sup>3</sup> ADCVDD and DVDD can be powered from an internal LDO or, alternatively, can be powered from external 1.8 V rail, which may result in a lower power solution.

<sup>4</sup> Pace is a digital function and incurs no power penalty.



## NOISE PERFORMANCE

Table 3. Typical Input Referred Noise over 0.5 Second Window ( $\mu\text{V p-p}$ )<sup>1</sup>

Mode	Data Rate <sup>2</sup>	GAIN 0 ( $\times 1.4$ ) $\pm 1$ VCM	GAIN 1 ( $\times 2.1$ ) $\pm 0.67$ VCM	GAIN 2 ( $\times 2.8$ ) $\pm 0.5$ VCM	GAIN 3 ( $\times 4.2$ ) $\pm 0.3$ VCM
Analog Lead Mode <sup>3</sup> High Performance Mode	2 kHz (0.5 Hz to 40 Hz)	8	6	5	4
	2 kHz (0.05 Hz to 150 Hz)	14	11	9	7.5

<sup>1</sup> Typical values measured at 25°C, not subject to production test.

<sup>2</sup> Data gathered using the 2 kHz packet/frame rate is measured over 0.5 seconds. The ADAS1000 internal programmable low-pass filter is configured for either 40 Hz or 150 Hz bandwidth. The data is gathered and post processed using a digital filter of either 0.05 Hz or 0.5 Hz to provide data over noted frequency bands.

<sup>3</sup> Analog lead mode as shown in Figure 58 and Figure 57.

Table 4. Typical Input Referred Noise ( $\mu\text{V p-p}$ )<sup>1</sup>

Mode	Data Rate <sup>2</sup>	GAIN 0 ( $\times 1.4$ ) $\pm 1$ VCM	GAIN 1 ( $\times 2.1$ ) $\pm 0.67$ VCM	GAIN 2 ( $\times 2.8$ ) $\pm 0.5$ VCM	GAIN 3 ( $\times 4.2$ ) $\pm 0.3$ VCM	
Analog Lead Mode <sup>3</sup> High Performance Mode	2 kHz (0.5 Hz to 40 Hz)	12	8.5	6	5	
	2 kHz (0.05 Hz to 150 Hz)	20	14.5	10	8.5	
	16 kHz	95	65	50	39	
	128 kHz	180	130	105	80	
	Low Power Mode	2 kHz (0.5 Hz to 40 Hz)	13	9.5	7.5	5.5
		2 kHz (0.05 Hz to 150 Hz)	22	15.5	12	9
		16 kHz	110	75	59	45
		128 kHz	215	145	116	85
Electrode Mode <sup>4</sup> High Performance Mode	2 kHz (0.5 Hz to 40 Hz)	13	9.5	8	5.5	
	2 kHz (0.05 Hz to 150 Hz)	21	15	11	9	
	16 kHz	100	70	57	41	
	128 kHz	190	139	110	85	
	Low Power Mode	2 kHz (0.5 Hz to 40 Hz)	14	9.5	7.5	5.5
		2 kHz (0.05 Hz to 150 Hz)	22	15.5	12	9.5
		16 kHz	110	75	60	45
		128 kHz	218	145	120	88
Digital Lead Mode <sup>5, 6</sup> High Performance Mode	2 kHz (0.5 Hz to 40 Hz)	16	11	9	6.5	
	2 kHz (0.05 Hz to 150 Hz)	25	19	15	10	
	16 kHz	130	90	70	50	
	Low Power Mode	2 kHz (0.5 Hz to 40 Hz)	18	12.5	10	7
		2 kHz (0.05 Hz to 150 Hz)	30	21	16	11
		16 kHz	145	100	80	58

<sup>1</sup> Typical values measured at 25°C, not subject to production test.

<sup>2</sup> Data gathered using the 2 kHz packet/frame rate is measured over 20 seconds. The ADAS1000 internal programmable low-pass filter is configured for either 40 Hz or 150 Hz bandwidth. The data is gathered and post processed using a digital filter of either 0.05 Hz or 0.5 Hz to provide data over noted frequency bands.

<sup>3</sup> Analog lead mode as shown in Figure 58 and Figure 57.

<sup>4</sup> Single-ended input electrode mode as shown in Figure 59 and Figure 57.

<sup>5</sup> Digital lead mode as shown in Figure 59 and Figure 57.

<sup>6</sup> Digital lead mode is available in 2 kHz and 16 kHz data rates.

**TIMING CHARACTERISTICS**

**Standard Serial Interface**

AVDD = 3.3 V ± 5%, IOVDD = 1.65 V to 3.6 V, AGND = DGND = 0 V, REFIN tied to REFOUT, externally supplied crystal/clock = 8.192 MHz. T<sub>A</sub> = -40°C to +85°C, unless otherwise noted. Typical specifications are mean values at T<sub>A</sub> = 25°C.

Table 5.

Parameter <sup>1</sup>	IOVDD			Unit	Description
	3.3 V	2.5 V	1.8 V		
Output Rate <sup>2</sup>	2		128	kHz	Across specified IOVDD supply range; three programmable output data rates available as configured in FRMCTL register (see Table 35) 2 kHz, 16 kHz, 128 kHz; use skip mode for slower rates
SCLK Cycle Time	25	40	50	ns min	See Table 19 for details on SCLK vs. packet data rates
t <sub>CSSA</sub>	8.5	9.5	12	ns min	$\overline{CS}$ valid setup time to rising SCLK
t <sub>CSHA</sub>	3	3	3	ns min	$\overline{CS}$ valid hold time to rising SCLK
t <sub>CH</sub>	8	8	8	ns min	SCLK high time
t <sub>CL</sub>	8	8	8	ns min	SCLK low time
t <sub>DO</sub>	8.5	11.5	20	ns typ	SCLK falling edge to SDO valid delay; SDO capacitance of 15 pF
	11	19	24	ns max	
t <sub>DS</sub>	2	2	2	ns min	SDI valid setup time from SCLK rising edge
t <sub>DH</sub>	2	2	2	ns min	SDI valid hold time from SCLK rising edge
t <sub>CSSD</sub>	2	2	2	ns min	$\overline{CS}$ valid setup time from SCLK rising edge
t <sub>CSHD</sub>	2	2	2	ns min	$\overline{CS}$ valid hold time from SCLK rising edge
t <sub>CSW</sub>	25	40	50	ns min	$\overline{CS}$ high time between writes (if used). Note that $\overline{CS}$ is an optional input, it may be tied permanently low. See a full description in the Serial Interfaces section.
t <sub>DRDY_CS</sub> <sup>2</sup>	0	0	0	ns min	DRDY to $\overline{CS}$ setup time
t <sub>CSO</sub>	6	7	9	ns typ	Delay from $\overline{CS}$ assert to SDO active
$\overline{RESET}$ Low Time <sup>2</sup>	20	20	20	ns min	Minimum pulse width; $\overline{RESET}$ is edge triggered

<sup>1</sup> Guaranteed by characterization, not production tested.

<sup>2</sup> Guaranteed by design, not production tested.

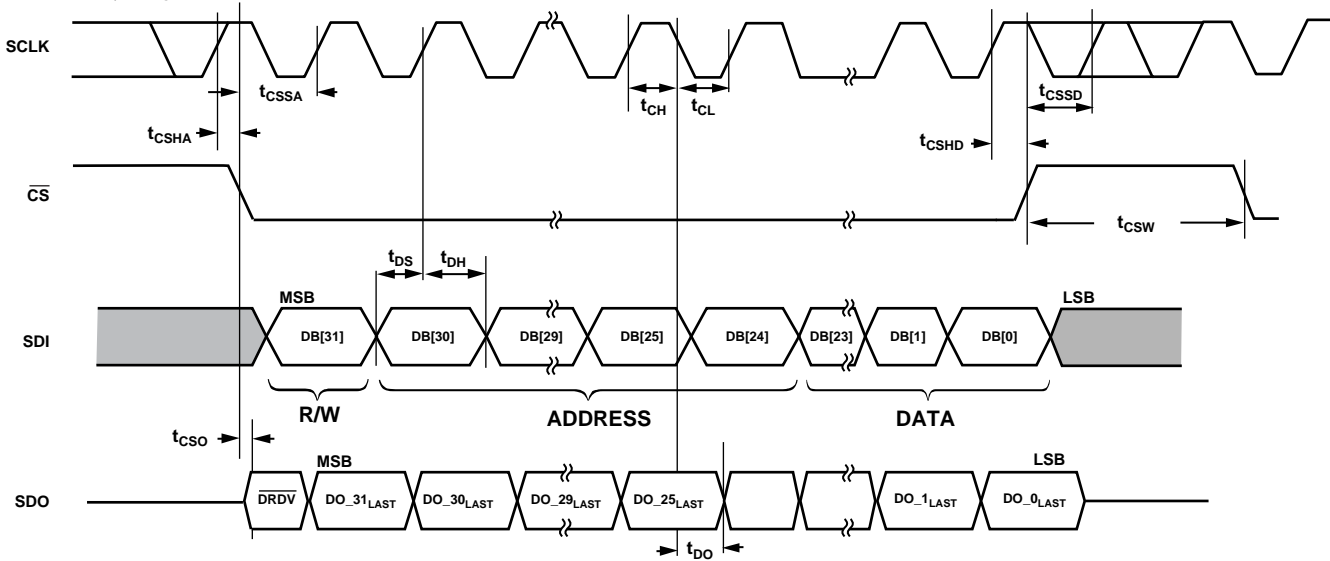

Figure 2. Data Read and Write Timing Diagram (CPHA = 1, CPOL = 1)

09860-002

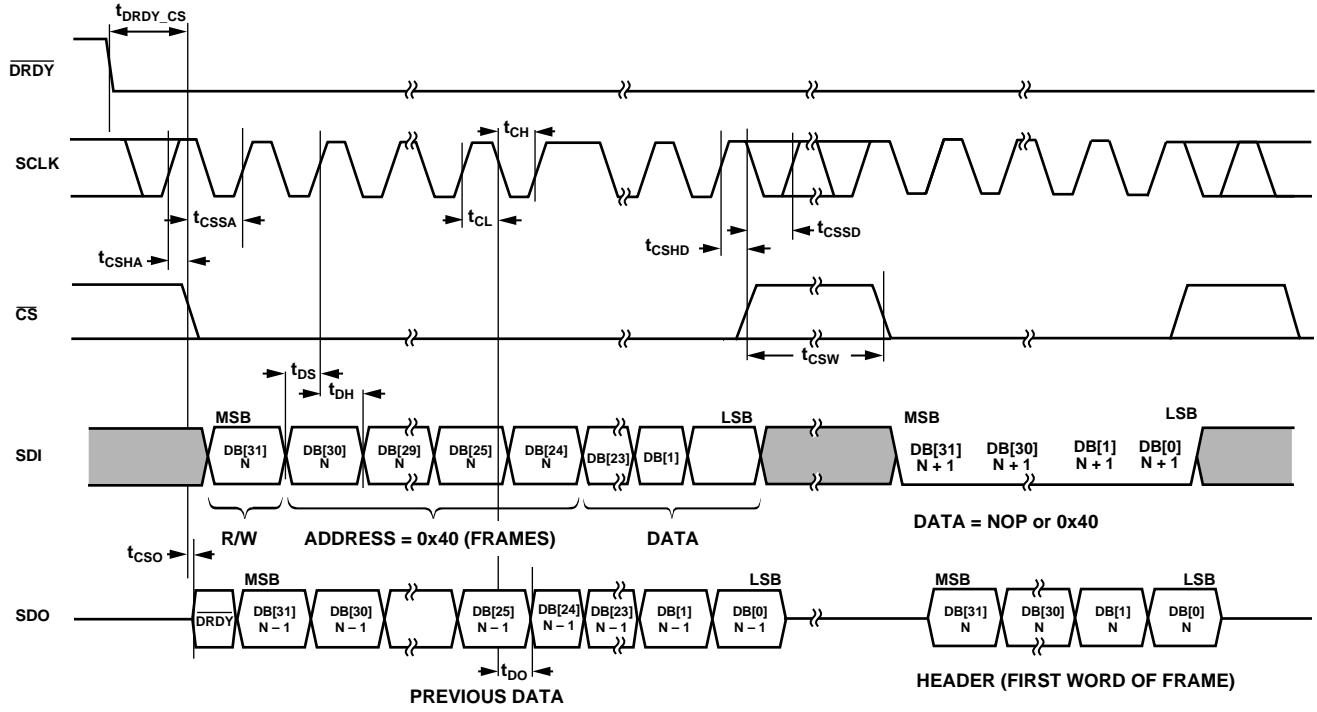

Figure 3. Starting Read Frame Data (CPHA = 1, CPOL = 1)

09B60-003

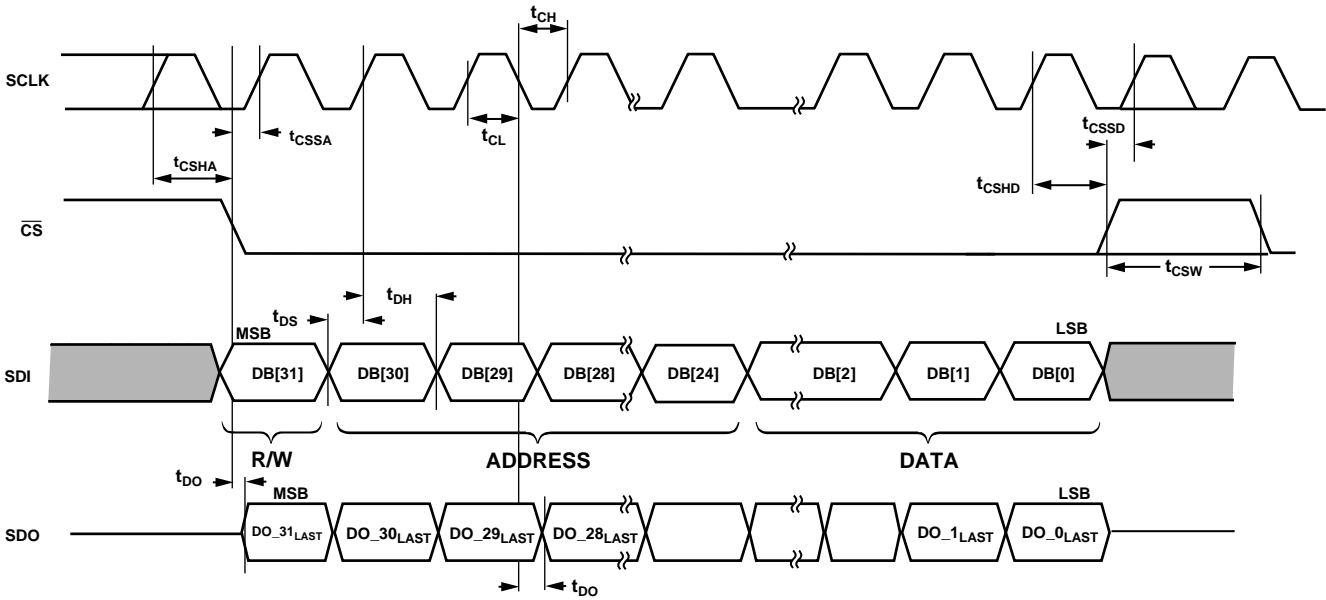

Figure 4. Data Read and Write Timing Diagram (CPHA = 0, CPOL = 0)

09B60-004

## Secondary Serial Interface (Master Interface for Customer-Based Digital Pace Algorithm) ADAS1000/ADAS1000-1 Only

AVDD = 3.3 V ± 5%, IOVDD = 1.65 V to 3.6 V, AGND = DGND = 0 V, REFIN tied to REFOUT, externally supplied crystal/clock = 8.192 MHz. T<sub>A</sub> = -40°C to +85°C, unless otherwise noted. Typical specifications are mean values at T<sub>A</sub> = 25°C. The following timing specifications apply for the master interface when ECGCTL register is configured for high performance mode (ECGCTL[3] = 1), see Table 26.

Table 6.

Parameter <sup>1</sup>	Min	Typ	Max	Unit	Description
Output Frame Rate <sup>2</sup>		128		kHz	All five 16-bit ECG data-words are available at frame rate of 128 kHz only
f <sub>SCLK</sub> <sup>2</sup>		2.5 × crystal frequency		MHz	Crystal frequency = 8.192 MHz
t <sub>MCSSA</sub>		24.4		ns	$\overline{\text{MCS}}$ valid setup time
t <sub>MDO</sub>		0		ns	MSCLK rising edge to MSDO valid delay
t <sub>MCSHD</sub>		48.8		ns	$\overline{\text{MCS}}$ valid hold time from MSCLK falling edge
t <sub>MCSW</sub>		2173		ns	$\overline{\text{MCS}}$ high time, SPIFW = 0, $\overline{\text{MCS}}$ asserted for entire frame as shown in Figure 5, and configured in Table 31
		2026		ns	$\overline{\text{MCS}}$ high time, SPIFW = 1, $\overline{\text{MCS}}$ asserted for each word in frame as shown in Figure 6 and configured in Table 31

<sup>1</sup> Guaranteed by characterization, not production tested.

<sup>2</sup> Guaranteed by design, not production tested.

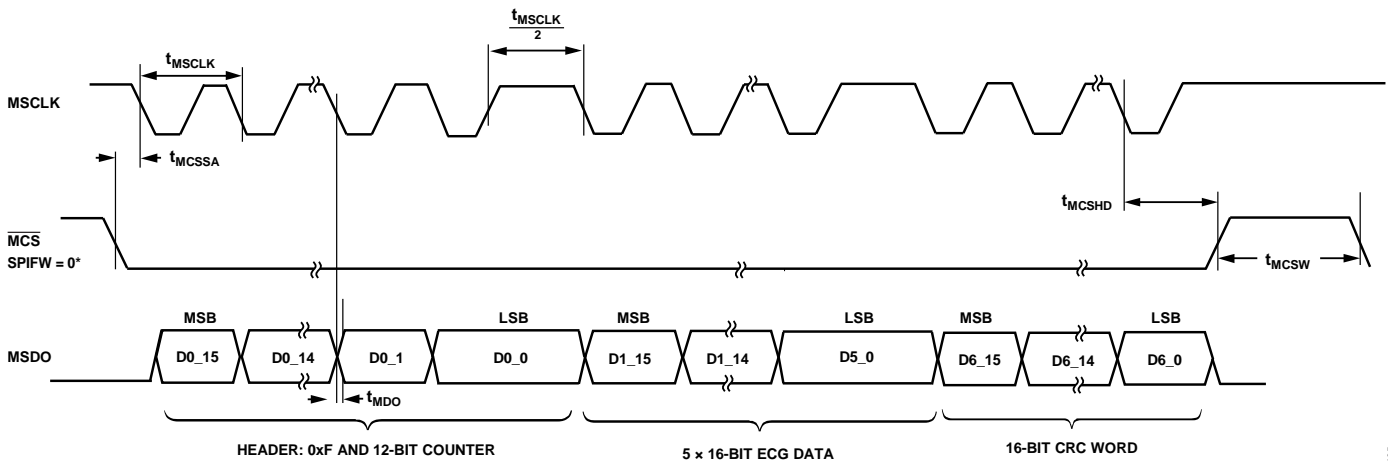

\*SPIFW = 0 PROVIDES  $\overline{\text{MCS}}$  FOR EACH FRAME, SCLK STAYS HIGH FOR 1/2 MSCLK CYCLE BETWEEN EACH WORD.

Figure 5. Data Read and Write Timing Diagram for SPIFW = 0, Showing Entire Packet Of Data (Header, 5 ECG Words, and CRC Word)

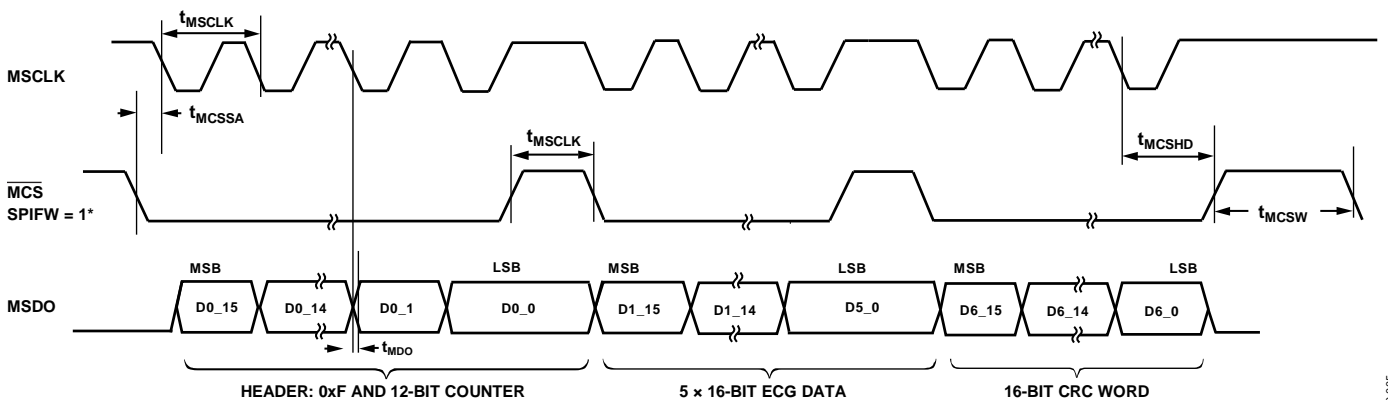

\*SPIFW = 1 PROVIDES  $\overline{\text{MCS}}$  FOR EACH FRAME, SCLK STAYS HIGH FOR 1 MSCLK CYCLE BETWEEN EACH WORD.

Figure 6. Data Read and Write Timing Diagram for SPIFW = 1, Showing Entire Packet Of Data (Header, 5 ECG Words, and CRC Word)

## ABSOLUTE MAXIMUM RATINGS

Table 7.

Parameter	Rating
AVDD to AGND	−0.3 V to +6 V
IOVDD to DGND	−0.3 V to +6 V
ADCVDD to AGND	−0.3 V to +2.5 V
DVDD to DGND	−0.3 V to +2.5 V
REFIN/REFOUT to REFGND	−0.3 V to +2.1 V
ECG and Analog Inputs to AGND	−0.3 V to AVDD + 0.3 V
Digital Inputs to DGND	−0.3 V to IOVDD + 0.3 V
REFIN to ADCVDD	ADCVDD + 0.3 V
AGND to DGND	−0.3 V to +0.3 V
REFGND to AGND	−0.3 V to +0.3 V
ECG Input Continuous Current	±10 mA
Storage Temperature Range	−65°C to +125°C
Operating Junction Temperature Range	−40°C to +85°C
Reflow Profile	J-STD 20 (JEDEC)
Junction Temperature	150°C max
ESD	
HBM	2500 V
FICDM	1000 V

Stresses above those listed under Absolute Maximum Ratings may cause permanent damage to the device. This is a stress rating only; functional operation of the device at these or any other conditions above those indicated in the operational section of this specification is not implied. Exposure to absolute maximum rating conditions for extended periods may affect device reliability.

## THERMAL RESISTANCE

$\theta_{JA}$  is specified for the worst-case conditions, that is, a device soldered in a circuit board for surface-mount packages.

Table 8. Thermal Resistance<sup>1</sup>

Package Type	$\theta_{JA}$	Unit
56-Lead LFCSP	35	°C/W
64-Lead LQFP	42.5	°C/W

<sup>1</sup> Based on JEDEC standard 4-layer (252P) high effective thermal conductivity test board (JESD51-7) and natural convection.

## ESD CAUTION



**ESD (electrostatic discharge) sensitive device.** Charged devices and circuit boards can discharge without detection. Although this product features patented or proprietary protection circuitry, damage may occur on devices subjected to high energy ESD. Therefore, proper ESD precautions should be taken to avoid performance degradation or loss of functionality.

PIN CONFIGURATIONS AND FUNCTION DESCRIPTIONS

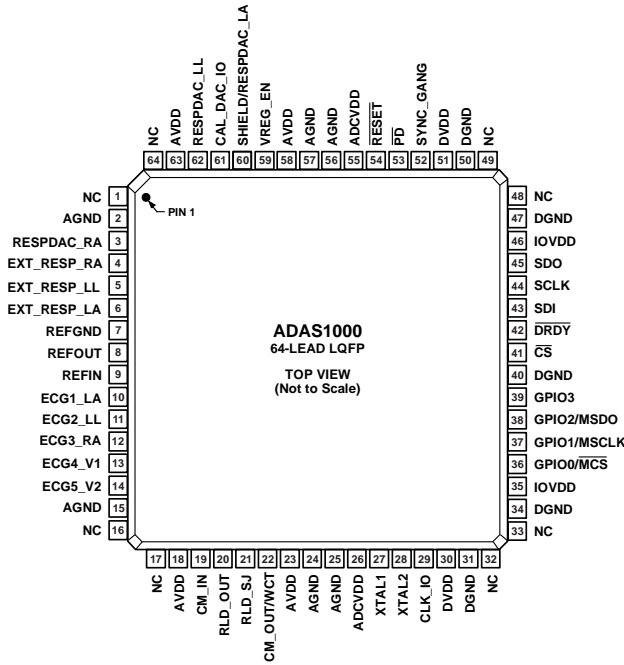

NOTES  
1. NC = NO CONNECT. DO NOT CONNECT TO THIS PIN.

Figure 7. ADAS1000 64-Lead LQFP Pin Configuration

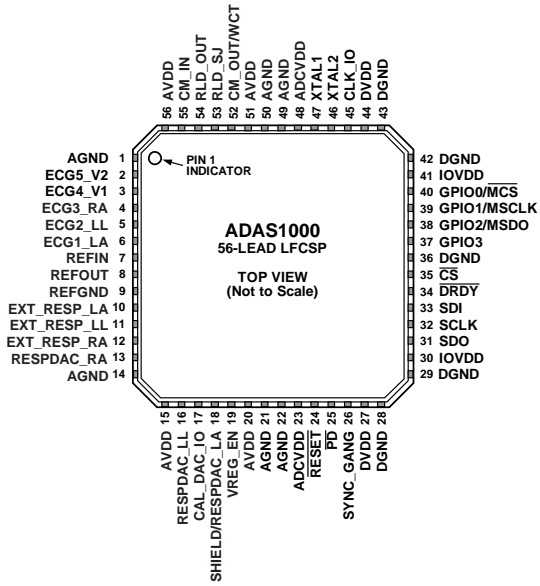

NOTES  
1. THE EXPOSED PADDLE IS ON THE TOP OF THE PACKAGE; IT IS CONNECTED TO THE MOST NEGATIVE POTENTIAL, AGND.

Figure 8. ADAS1000 56-Lead LFCSP Pin Configuration

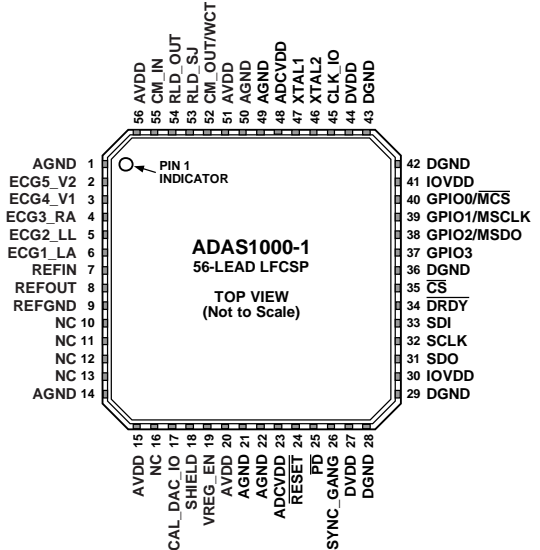

NOTES  
1. THE EXPOSED PADDLE IS ON THE TOP OF THE PACKAGE; IT IS CONNECTED TO THE MOST NEGATIVE POTENTIAL, AGND.

Figure 9. ADAS1000-1 56-Lead LFCSP Pin Configuration

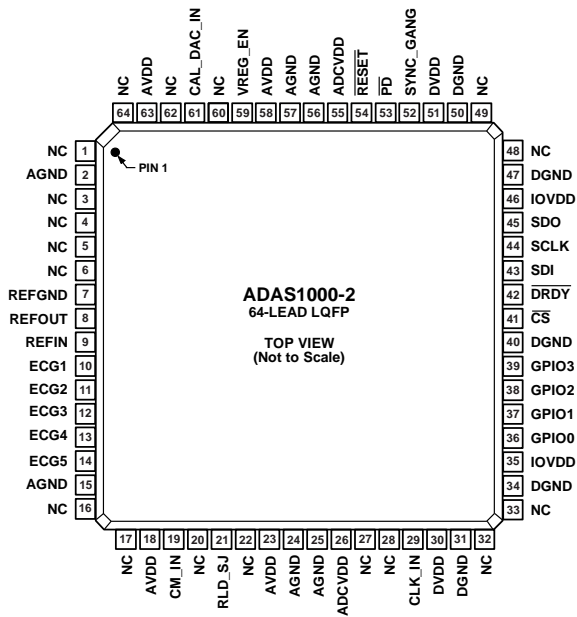

NOTES  
1. NC = NO CONNECT. DO NOT CONNECT TO THIS PIN.

Figure 10. ADAS1000-2 Companion 64-Lead LQFP Pin Configuration

09866-010

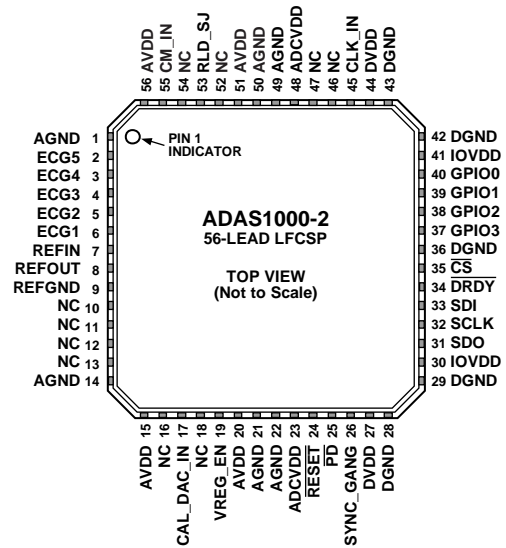

NOTES  
1. THE EXPOSED PADDLE IS ON THE TOP OF THE PACKAGE; IT IS CONNECTED TO THE MOST NEGATIVE POTENTIAL, AGND.  
2. NC = NO CONNECT. DO NOT CONNECT TO THIS PIN.

Figure 11. ADAS1000-2 Companion 56-Lead LFCSP Pin Configuration

09866-010

Table 9. Pin Function Descriptions

ADAS1000		ADAS1000-1	ADAS1000-2		Mnemonic	Description
LQFP	LFCSP	LFCSP	LQFP	LFCSP		
18, 23, 58, 63	15, 20, 51, 56	15, 20, 51, 56	18, 23, 58, 63	15, 20, 51, 56	AVDD	Analog Supply. See recommendations for bypass capacitors in the Power Supply, Grounding, and Decoupling Strategy section.
35, 46	30, 41	30, 41	35, 46	30, 41	IOVDD	Digital Supply for Digital Input/Output Voltage Levels. See recommendations for bypass capacitors in the Power Supply, Grounding, and Decoupling Strategy section.
26, 55	23, 48	23, 48	26, 55	23, 48	ADCVDD	Analog Supply for ADC. There is an on-chip linear regulator providing the supply voltage for the ADCs. This pin is primarily provided for decoupling purposes; however, the pin may also be supplied by an external 1.8 V supply should the user wish to use a more efficient supply to minimize power dissipation. In this case, use the VREG_EN pin tied to ground to disable the ADCVDD and DVDD regulators. The ADCVDD pin should not be used to supply other functions. See recommendations for bypass capacitors in the Power Supply, Grounding, and Decoupling Strategy section.
30, 51	27, 44	27, 44	30, 51	27, 44	DVDD	Digital Supply. There is an on-chip linear regulator providing the supply voltage for the digital core. This pin is primarily provided for decoupling purposes; however, the pin may also be overdriven supplied by an external 1.8 V supply should the user wish to use a more efficient supply to minimize power dissipation. In this case, use the VREG_EN pin tied to ground to disable the ADCVDD and DVDD regulators. See recommendations for bypass capacitors in the Power Supply, Grounding, and Decoupling Strategy section.
2, 15, 24, 25, 56, 57	1, 14, 21, 22, 49, 50	1, 14, 21, 22, 49, 50	2, 15, 24, 25, 56, 57	1, 14, 21, 22, 49, 50	AGND	Analog Ground.
31, 34, 40, 47, 50	28, 29, 36, 42, 43	28, 29, 36, 42, 43	31, 34, 40, 47, 50	28, 29, 36, 42, 43	DGND	Digital Ground.
59	19	19	59	19	VREG_EN	Enables or disables the internal voltage regulators used for ADCVDD and DVDD. Tie this pin to AVDD to enable or tie this pin to ground to disable the internal voltage regulators.
10	6	6			ECG1_LA	Analog Input, Left Arm (LA).
11	5	5			ECG2_LL	Analog Input, Left Leg (LL).
12	4	4			ECG3_RA	Analog Input, Right Arm (RA).
13	3	3			ECG4_V1	Analog Input, Chest Electrode 1 or Auxiliary Biopotential Input (V1).

ADAS1000		ADAS1000-1	ADAS1000-2		Mnemonic	Description
LQFP	LFCSP	LFCSP	LQFP	LFCSP		
14	2	2			ECG5_V2	Analog Input, Chest Electrode 2 or Auxiliary Biopotential Input (V2).
			10	6	ECG1	Analog Input 1.
			11	5	ECG2	Analog Input 2.
			12	4	ECG3	Analog Input 3.
			13	3	ECG4	Analog Input 4.
			14	2	ECG5	Analog Input 5.
4	12				EXT_RESP_RA	Optional External Respiration Input.
5	11				EXT_RESP_LL	Optional External Respiration Input.
6	10				EXT_RESP_LA	Optional External Respiration Input.
62	16				RESPDAC_LL	Optional path for higher performance respiration resolution, respiration DAC drive, Negative Side 0.
60	18				SHIELD/ RESPDAC_LA	Shared Pin (User-Configured). Output of Shield Driver (SHIELD). Optional Path for Higher Performance Respiration Resolution, Respiration DAC Drive, Negative Side 1 (RESPDAC_LA).
3	13				RESPDAC_RA	Optional Path for Higher Performance Respiration Resolution, Respiration DAC Drive, Positive Side.
22	52	52			CM_OUT/WCT	Common-Mode Output Voltage (Average of Selected Electrodes). Not intended to drive current.
19	55	55	19	55	CM_IN	Common-Mode Input.
21	53	53	21	53	RLD_SJ	Summing Junction for Right Leg Drive Amplifier.
20	54	54			RLD_OUT	Output and Feedback Junction for Right Leg Drive Amplifier.
61	17	17			CAL_DAC_IO	Calibration DAC Input/Output. Output for a master device, input for a slave. Not intended to drive current.
9	7	7	9	7	REFIN	Reference Input. For standalone mode, use REFOUT connected to REFIN. External 10 $\mu$ F with ESR < 0.2 $\Omega$ in parallel with 0.1 $\mu$ F bypass capacitors to GND are required and should be placed as close to the pin as possible. An external reference can be connected to REFIN.
8	8	8	8	8	REFOUT	Reference Output.
7	9	9	7	9	REFGND	Reference Ground. Connect to a clean ground.
27, 28	47, 46	47, 46			XTAL1, XTAL2	External crystal connects between these two pins; external clock drive should be applied to CLK_IO. Each XTAL pin requires 15 pF to ground.
29	45	45			CLK_IO	Buffered Clock Input/Output. Output for a master device; input for a slave. Powers up in high impedance.
41	35	35	41	35	$\overline{CS}$	Chip Select and Frame Sync, Active Low. $\overline{CS}$ can be used to frame each word or to frame the entire suite of data in framing mode.
44	32	32	44	32	SCLK	Clock Input. Data is clocked into the shift register on a rising edge and clocked out on a falling edge.
43	33	33	43	33	SDI	Serial Data Input.
53	25	25	53	25	$\overline{PD}$	Power-Down, Active Low.
45	31	31	45	31	SDO	Serial Data Output. This pin is used for reading back register configuration data and for the data frames.
42	34	34	42	34	$\overline{DRDY}$	Digital Output. This pin indicates that conversion data is ready to be read back when low, busy when high. When reading packet data, the entire packet must be read to allow $\overline{DRDY}$ to return high.
54	24	24	54	24	$\overline{RESET}$	Digital Input. This pin has an internal pull-up. This pin resets all internal nodes to their power-on reset values.
52	26	26	52	26	SYNC_GANG	Digital Input/Output (Output on Master, Input on Slave). Used for synchronization control where multiple devices are connected together. Powers up in high impedance.
36	40	40			GPIO0/ $\overline{MCS}$	General-Purpose I/O or Master 128 kHz SPI $\overline{CS}$ .
37	39	39			GPIO1/ $\overline{MSCLK}$	General-Purpose I/O or Master 128 kHz SPI SCLK.
38	38	38			GPIO2/ $\overline{MSDO}$	General-Purpose I/O or Master 128 kHz SPI SDO.
39	37	37			GPIO3	General-Purpose I/O.



ADAS1000		ADAS1000-1	ADAS1000-2		Mnemonic	Description
LQFP	LFCSP	LFCSP	LQFP	LFCSP		
1, 16, 17, 32, 33, 48, 49, 64		10, 11, 12, 13, 16	1, 3, 4, 5, 6, 16, 17, 20, 22, 27, 28, 32, 33, 48, 49, 60, 62, 64	10, 11, 12, 13, 16, 18, 46, 47, 52, 54	NC	No connect. Do not connect to these pins. (see Figure 7, Figure 9, Figure 10, Figure 11).
			36	40	GPIO0	General-Purpose I/O.
			37	39	GPIO1	General-Purpose I/O.
			38	38	GPIO2	General-Purpose I/O.
			39	37	GPIO3	General-Purpose I/O.
		18			SHIELD	Output of Shield Driver.
			61	17	CAL_DAC_IN	Calibration DAC Input. Input for companion device. Calibration signal should come from the master.
			29	45	CLK_IN	Buffered Clock Input. This pin should be driven from the master CLK_IO pin.
	57	57		57	EPAD	Exposed Pad. The exposed paddle is on the top of the package; it is connected to the most negative potential, AGND.

TYPICAL PERFORMANCE CHARACTERISTICS

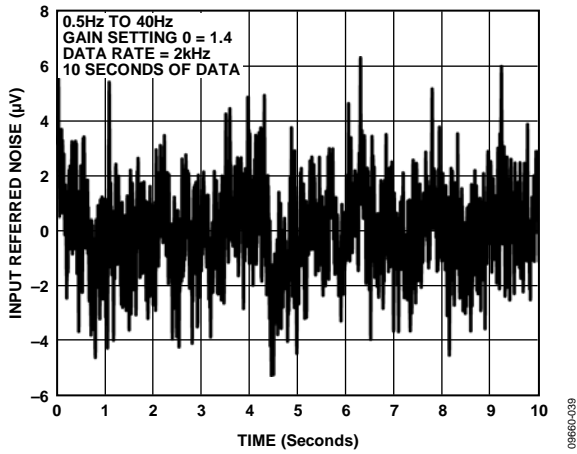

Figure 12. Input Referred Noise for 0.5 Hz to 40 Hz Bandwidth, 2 kHz Data Rate, GAIN 0 (1.4)

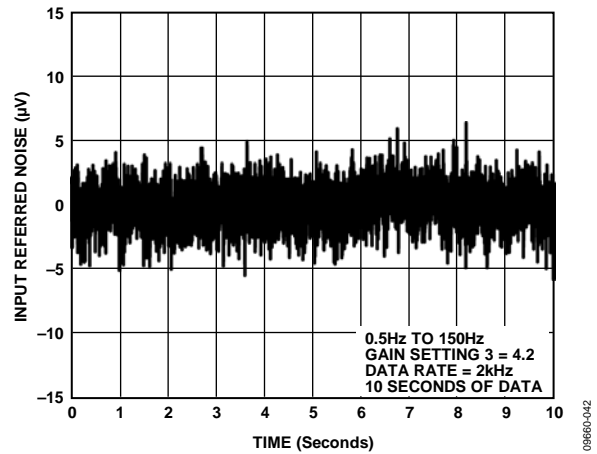

Figure 15. Input Referred Noise for 0.5 Hz to 150 Hz Bandwidth, 2 kHz Data Rate, GAIN 3 (4.2)

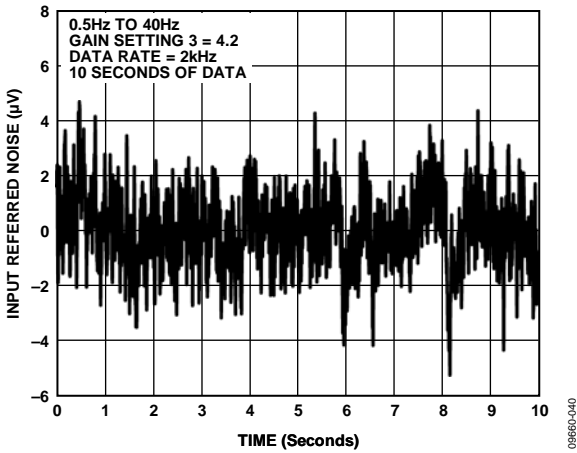

Figure 13. Input Referred noise for 0.5 Hz to 40 Hz Bandwidth, 2 kHz Data Rate, GAIN 3 (4.2)

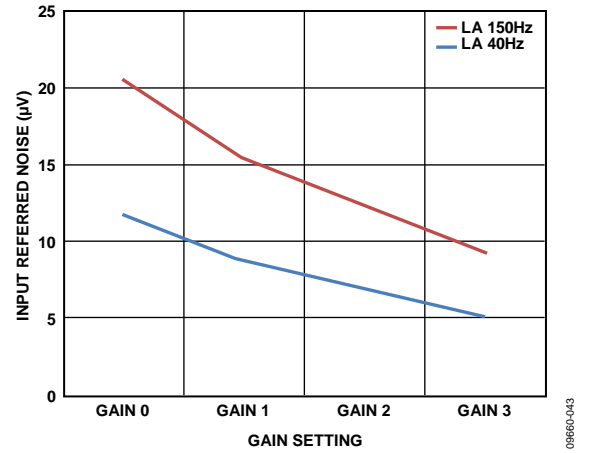

Figure 16. ECG Channel Noise Performance over a 0.5 Hz to 40 Hz or 0.5 Hz to 150 Hz Bandwidth vs. Gain Setting

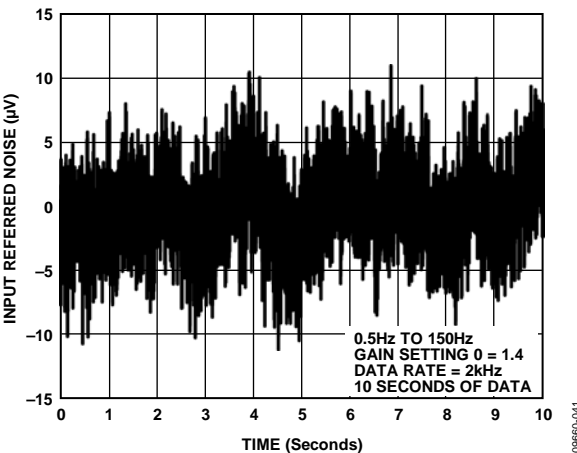

Figure 14. Input Referred Noise for 0.5 Hz to 150 Hz Bandwidth, 2 kHz Data Rate, GAIN 0 (1.4)

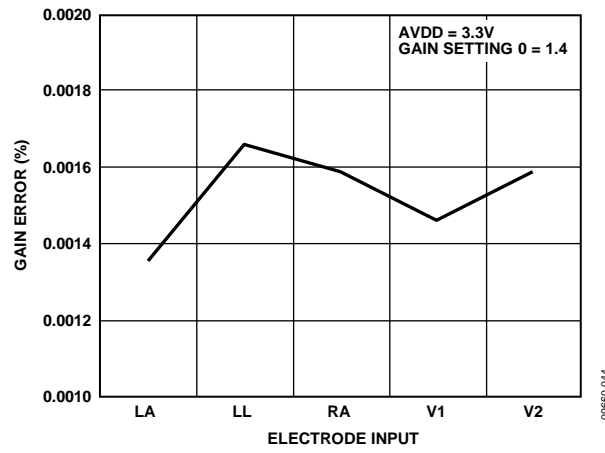

Figure 17. Typical Gain Error Across Channels

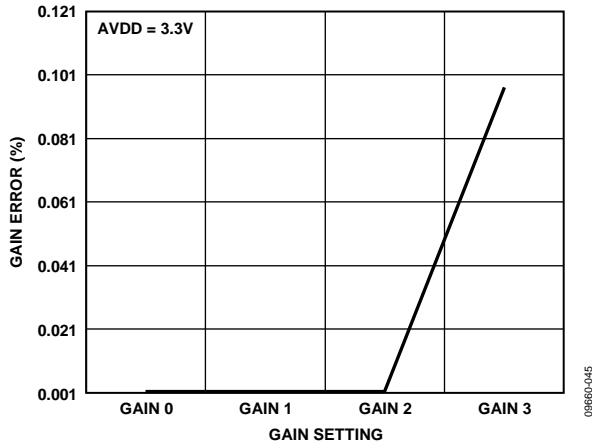

Figure 18. Typical Gain Error vs. Gain

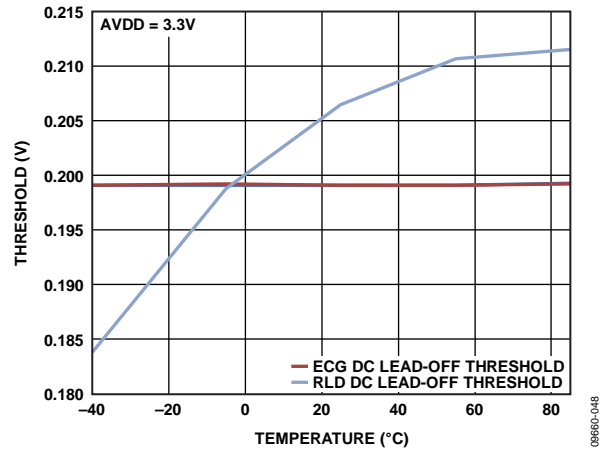

Figure 21. DC Lead-Off Comparator Low Threshold vs. Temperature

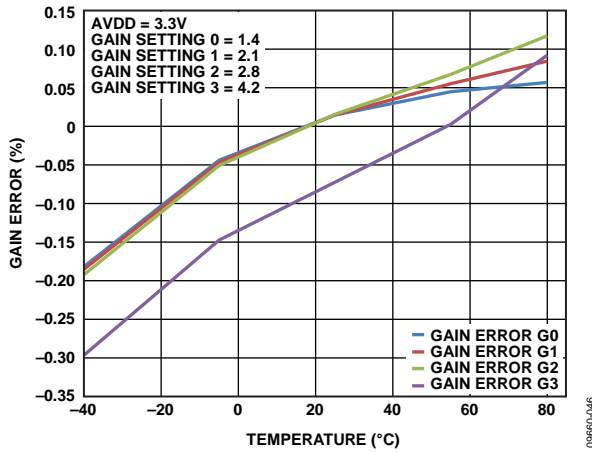

Figure 19. Typical Gain Error for All Gain Settings Across Temperature

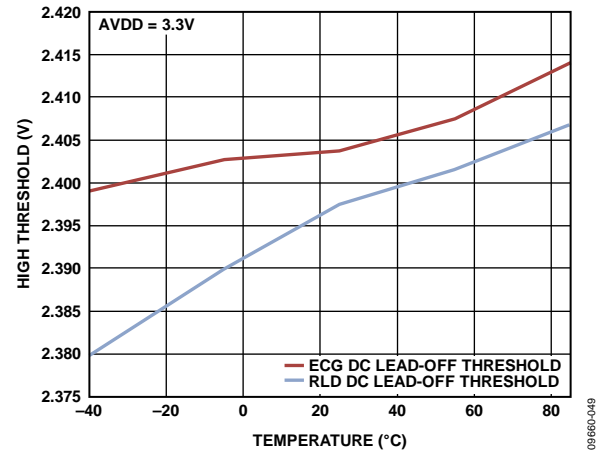

Figure 22. DC Lead-Off Comparator High Threshold vs. Temperature

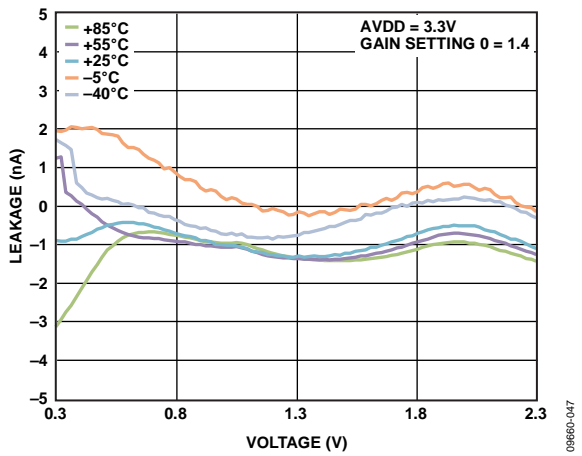

Figure 20. Typical ECG Channel Leakage Current over Input Voltage Range vs. Temperature

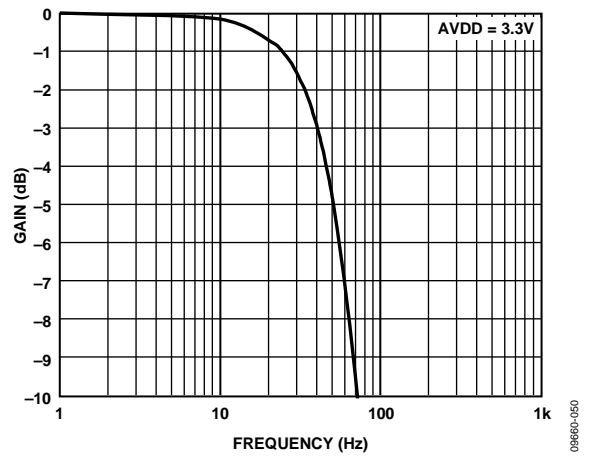

Figure 23. Filter Response with 40 Hz Filter Enabled, 2 kHz Data Rate; See Figure 72 for Digital Filter Overview

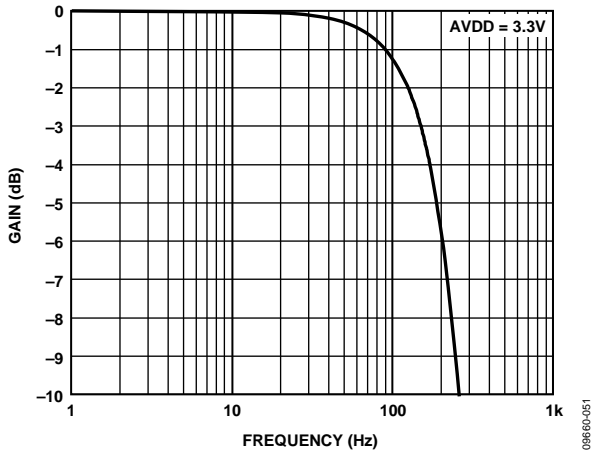

Figure 24. Filter Response with 150 Hz Filter Enabled, 2 kHz Data Rate; See Figure 72 for Digital Filter Overview

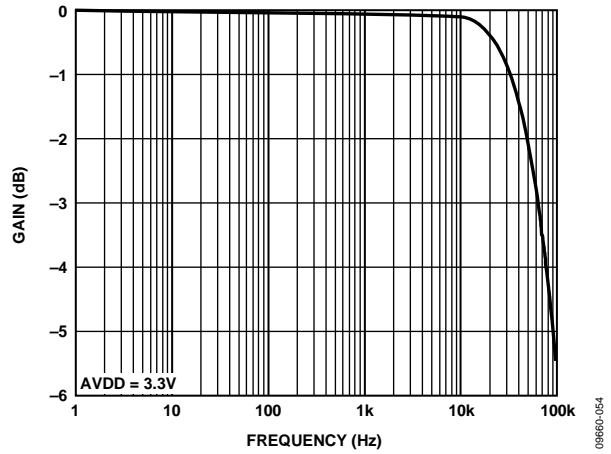

Figure 27. Analog Channel Bandwidth

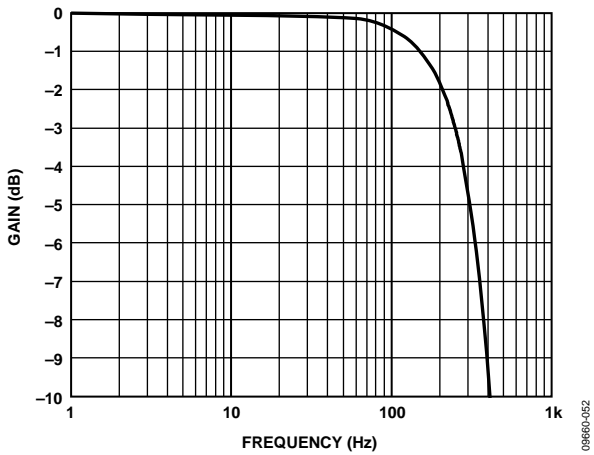

Figure 25. Filter Response with 250 Hz Filter Enabled, 2 kHz Data Rate; See Figure 72 for Digital Filter Overview

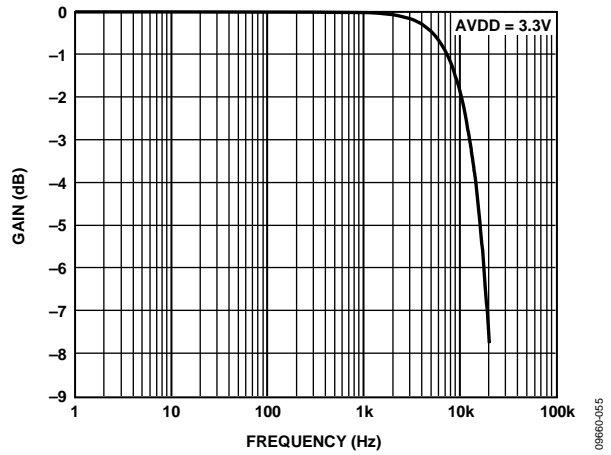

Figure 28. Filter Response Running at 128 kHz Data Rate; See Figure 72 for Digital Filter Overview

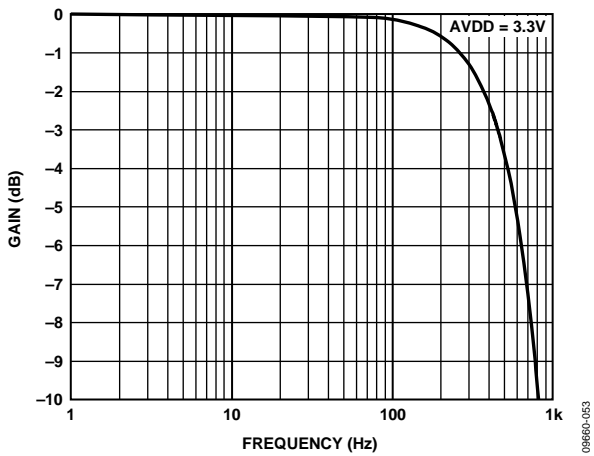

Figure 26. Filter Response with 450 Hz Filter Enabled, 2 kHz Data Rate; See Figure 72 for Digital Filter Overview

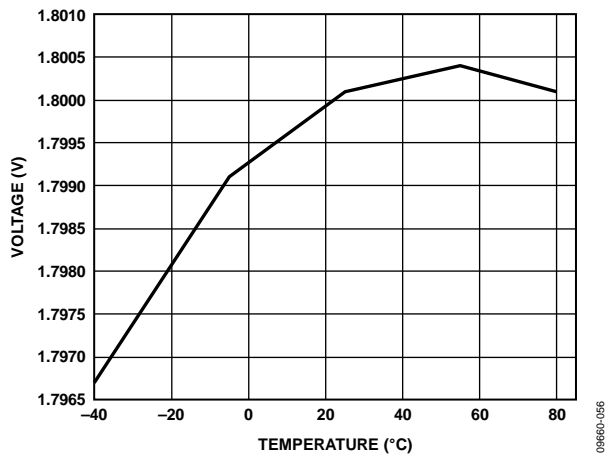

Figure 29. Typical Internal VREF vs. Temperature

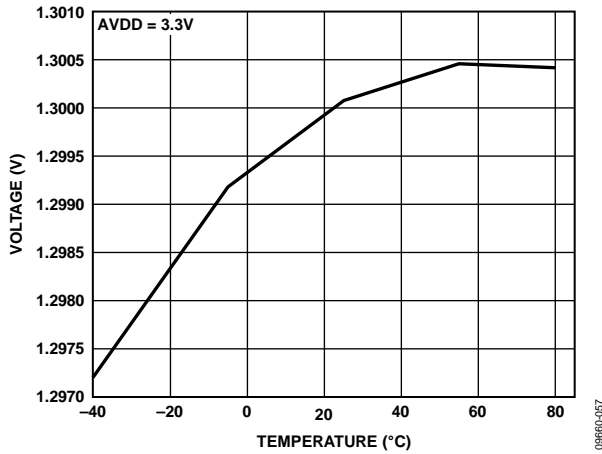

Figure 30. VCM\_REF vs. Temperature

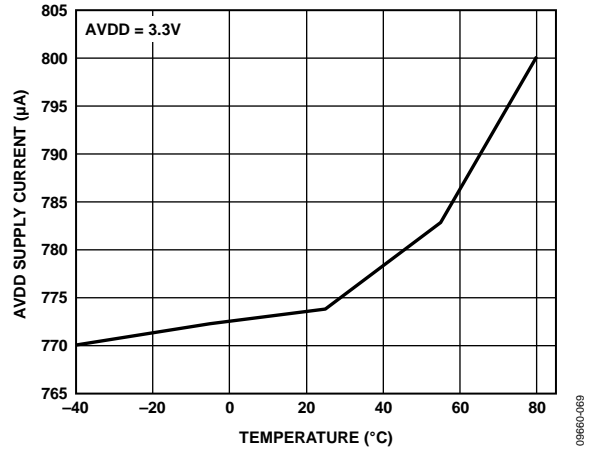

Figure 33. Typical AVDD Supply Current vs. Temperature in Standby Mode

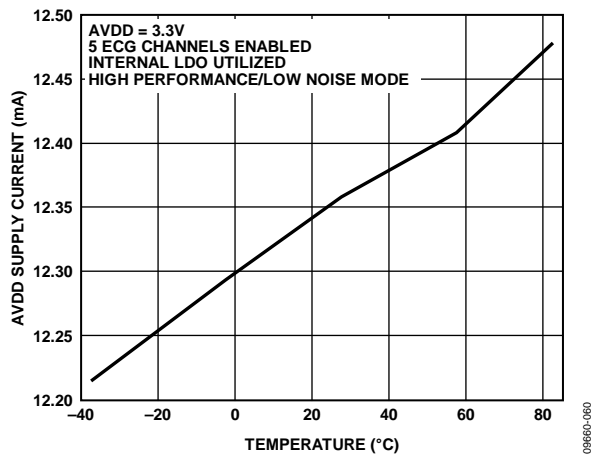

Figure 31. Typical AVDD Supply Current vs. Temperature, Using Internal ADVCD/DVDD Supplies

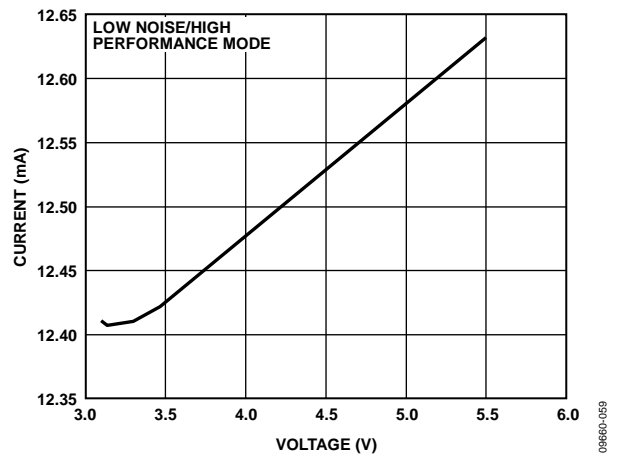

Figure 34. Typical AVDD Supply Current vs. AVDD Supply Voltage

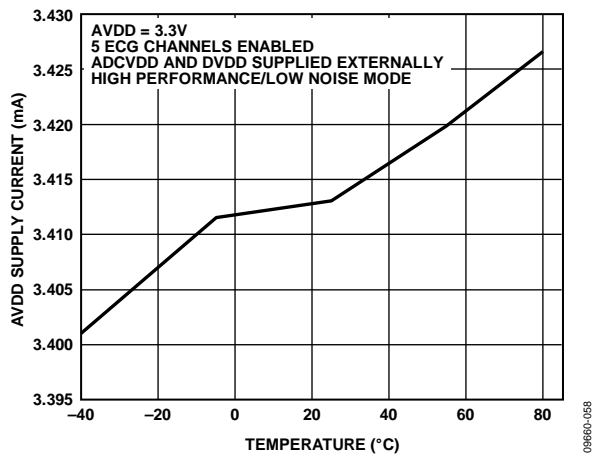

Figure 32. Typical AVDD Supply Current vs. Temperature, Using Externally Supplied ADVCD/DVDD

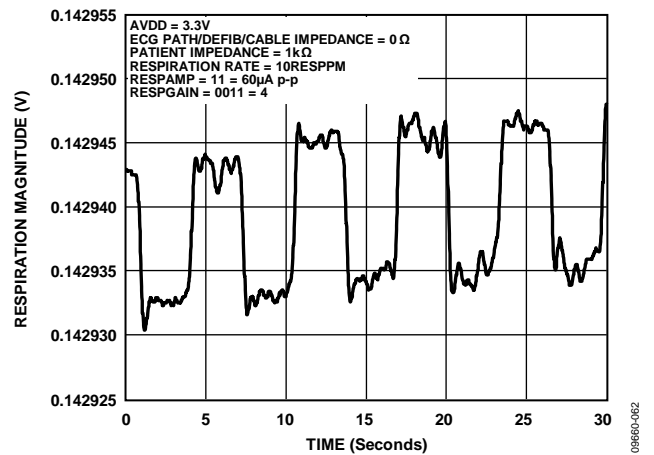

Figure 35. Respiration with 200 mΩ Impedance Variation, Using Internal Respiration Paths and Measured with a 0 Ω Patient Cable

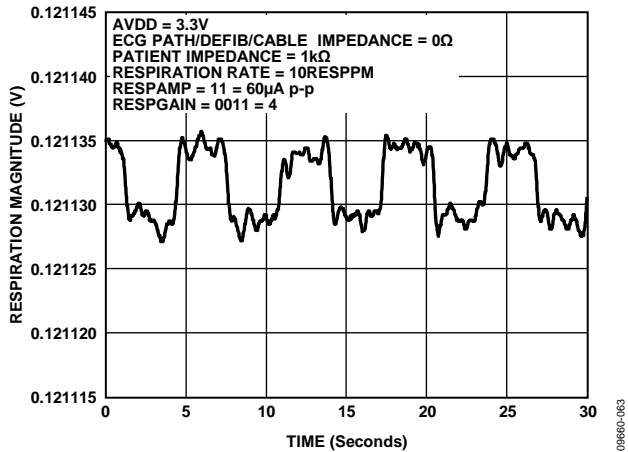

Figure 36. Respiration with 100 mΩ Impedance Variation, Using Internal Respiration Paths and Measured with a 0Ω Patient Cable

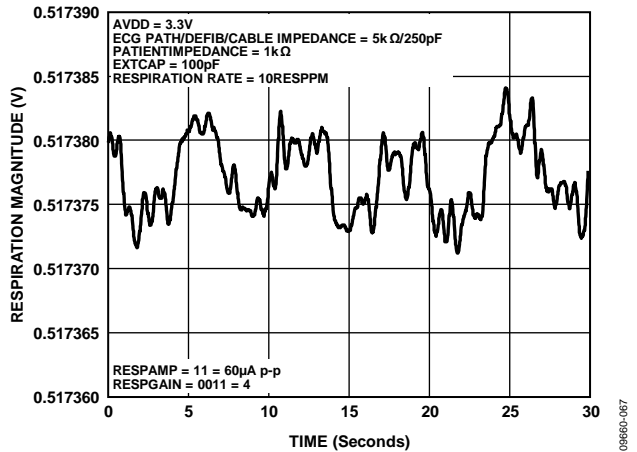

Figure 39. Respiration with 200 mΩ Impedance Variation, Using External Respiration DAC Driving 100 pF External Capacitor and Measured with a 5 kΩ Patient Cable

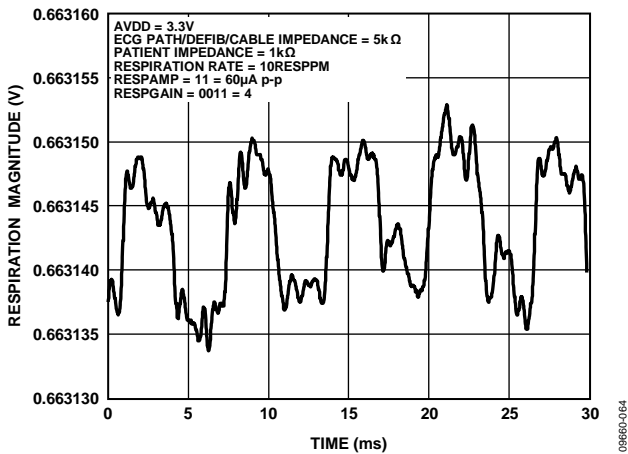

Figure 37. Respiration with 200 mΩ Impedance Variation, Using Internal Respiration Paths and Measured with a 5 kΩ Patient Cable

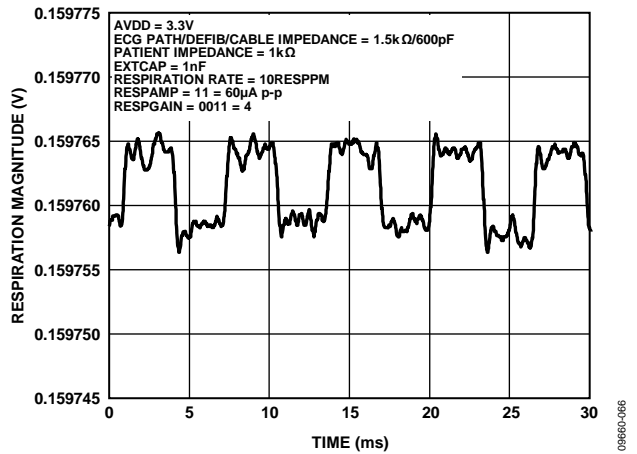

Figure 40. Respiration with 200 mΩ Impedance Variation, Using External Respiration DAC Driving 1 nF External Capacitor and Measured with a 1.5 kΩ Patient Cable

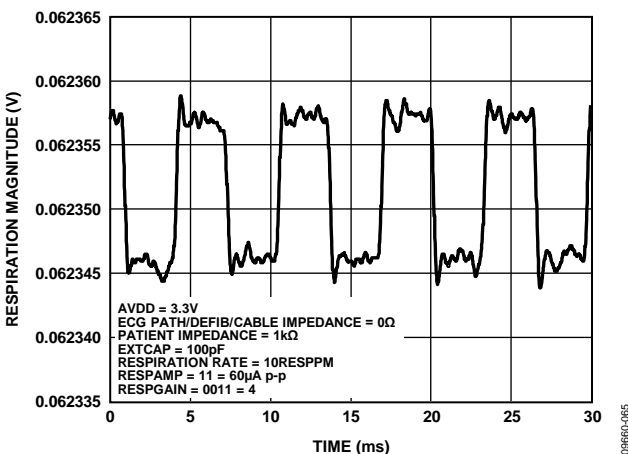

Figure 38. Respiration with 200 mΩ Impedance Variation, Using External Respiration DAC Driving 100 pF External Capacitor and Measured with a 0Ω Patient Cable

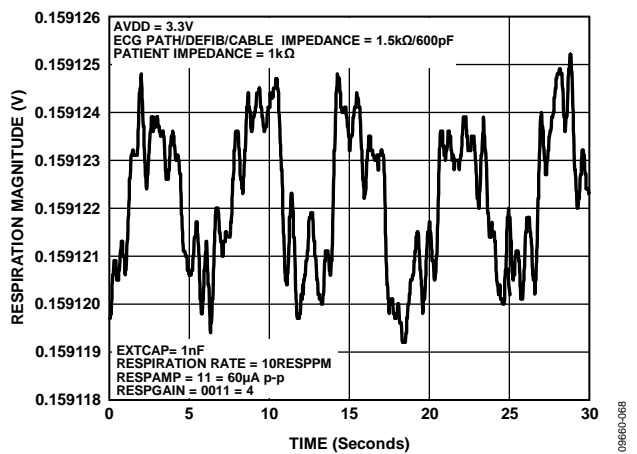

Figure 41. Respiration with 100 mΩ Impedance Variation, Using External Respiration DAC Driving 1 nF External Capacitor and Measured with a 1.5 kΩ Patient Cable

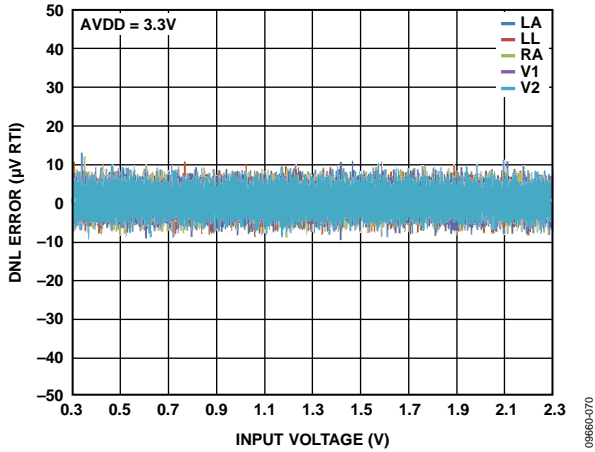

Figure 42. DNL vs. Input Voltage Range Across Electrodes at 25°C

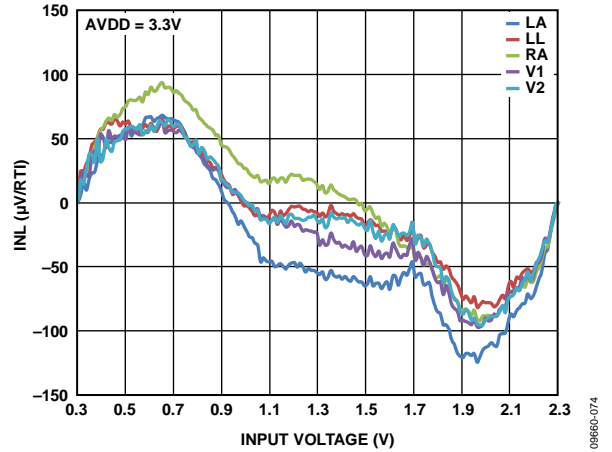

Figure 45. INL vs. Input Voltage Across Electrode Channel for 2 kHz Data Rate

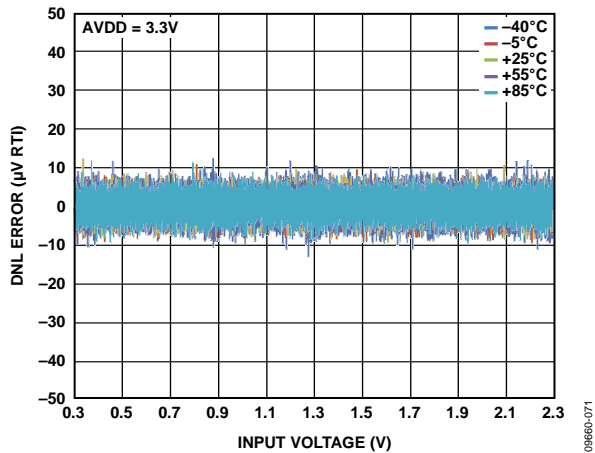

Figure 43. DNL vs. Input Voltage Range Across Temperature

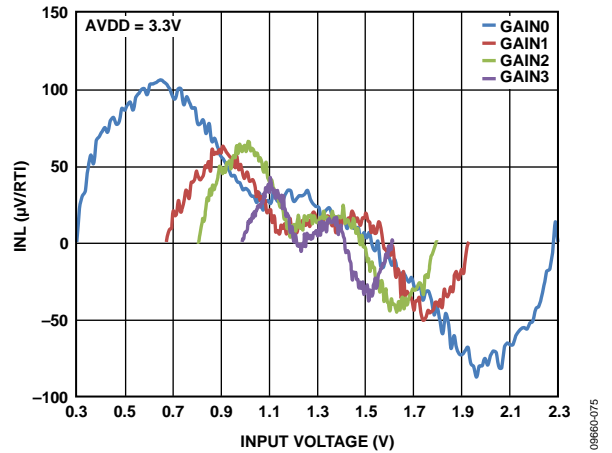

Figure 46. INL vs. Input Voltage Across Gain Setting for 16 kHz Data Rate

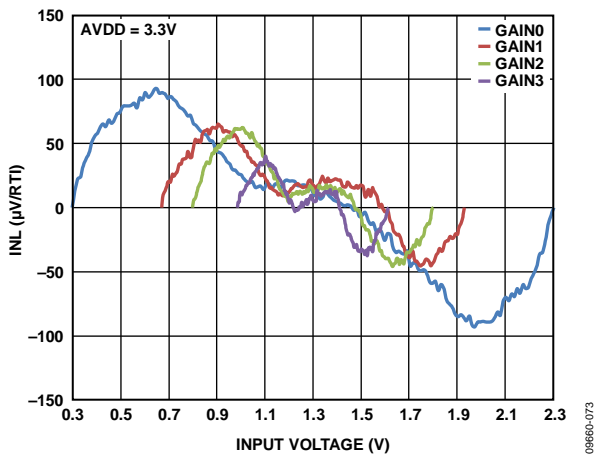

Figure 44. INL vs. Input Voltage Across Gain Setting for 2 kHz Data Rate

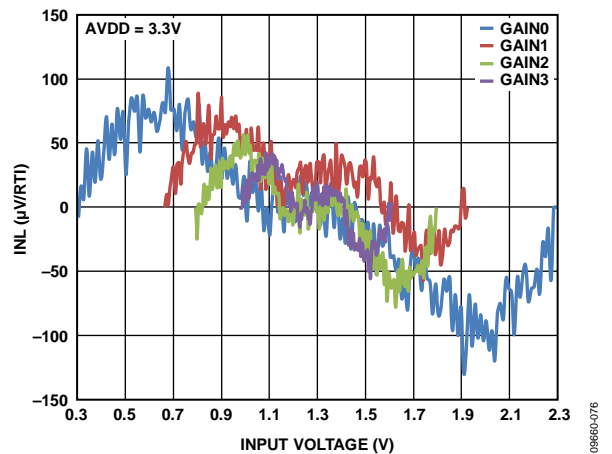

Figure 47. INL vs. Input Voltage Across Gain Setting for 128 kHz Data Rate

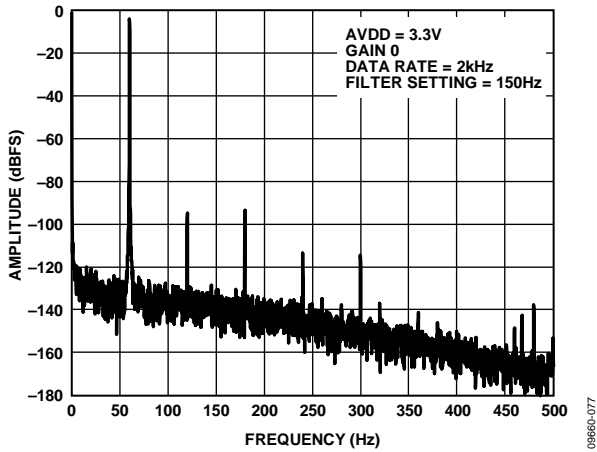

Figure 48. FFT with 60 Hz Input Signal

09860-077

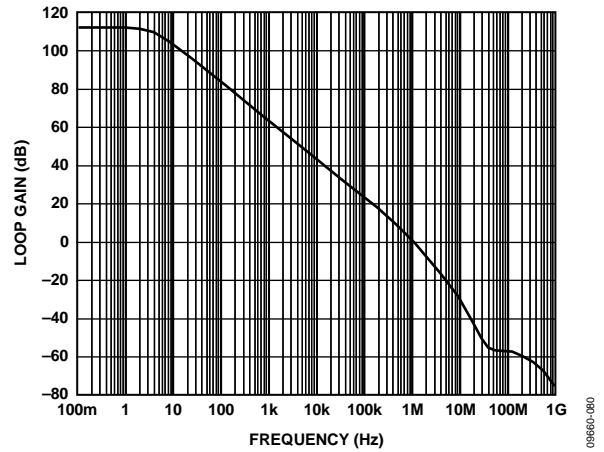

Figure 51. Open-Loop Gain Response of ADAS1000 Right Leg Drive Amplifier Without Loading

09860-080

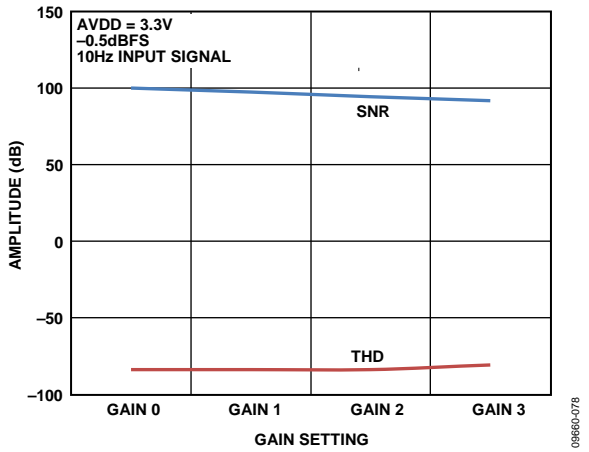

Figure 49. SNR and THD Across Gain Settings

09860-078

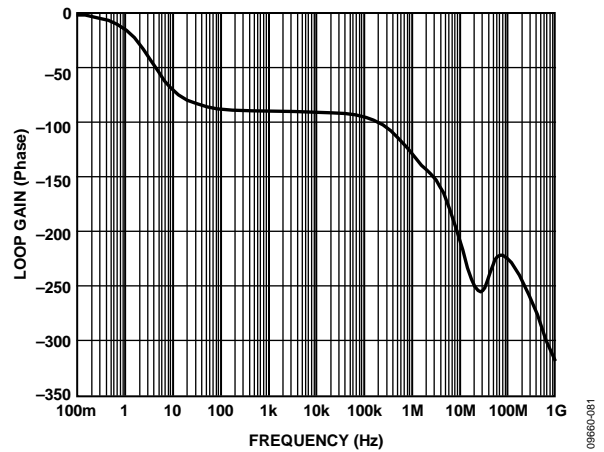

Figure 52. Open-Loop Phase Response of ADAS1000 Right Leg Drive Amplifier Without Loading

09860-081

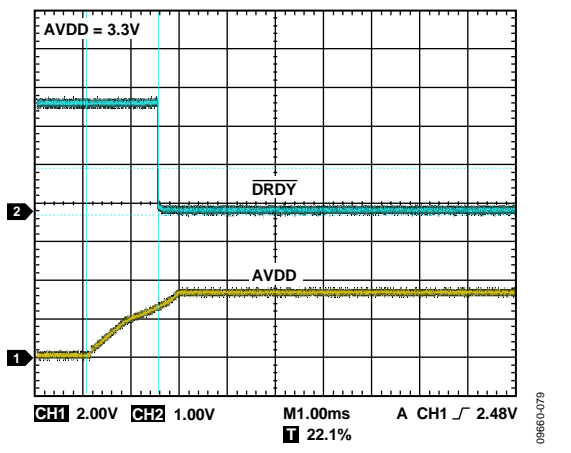

Figure 50. Power Up AVDD Line to DRDY Going Low (Ready)

09860-079



# APPLICATIONS INFORMATION

## OVERVIEW

The ADAS1000/ADAS1000-1/ADAS1000-2 are electro cardiac (ECG) front-end solutions targeted at a variety of medical applications. In addition to ECG measurements, the ADAS1000 version also measures thoracic impedance (respiration) and detects pacing artifacts, providing all the measured information to the host controller in the form of a data frame supplying either lead/vector or electrode data at programmable data rates. The ADAS1000/ADAS1000-1/ADAS1000-2 are designed to simplify the task of acquiring ECG signals for use in both

monitor and diagnostic applications. Value-added cardiac post processing may be executed externally on a DSP, microprocessor, or FPGA. The ADAS1000/ADAS1000-1/ADAS1000-2 are designed for operation in both low power, portable telemetry applications and line powered systems; therefore, the parts offer power/noise scaling to ensure suitability to these varying requirements.

The devices also offer a suite of dc and ac test excitation via a calibration DAC feature and CRC redundancy checks in addition to read-back of all relevant register address space.

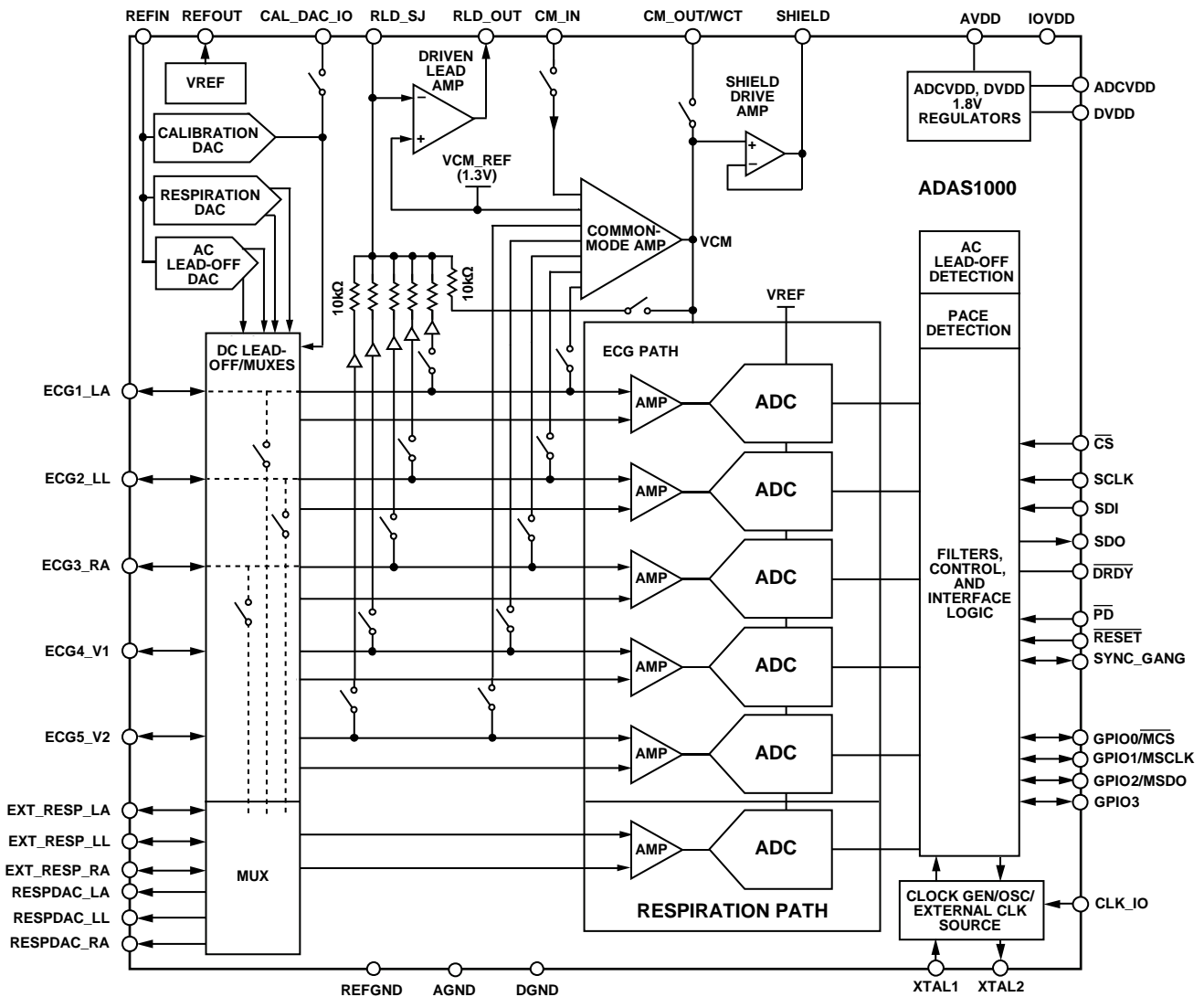

Figure 53. ADAS1000 Simplified Block Diagram

098660-011

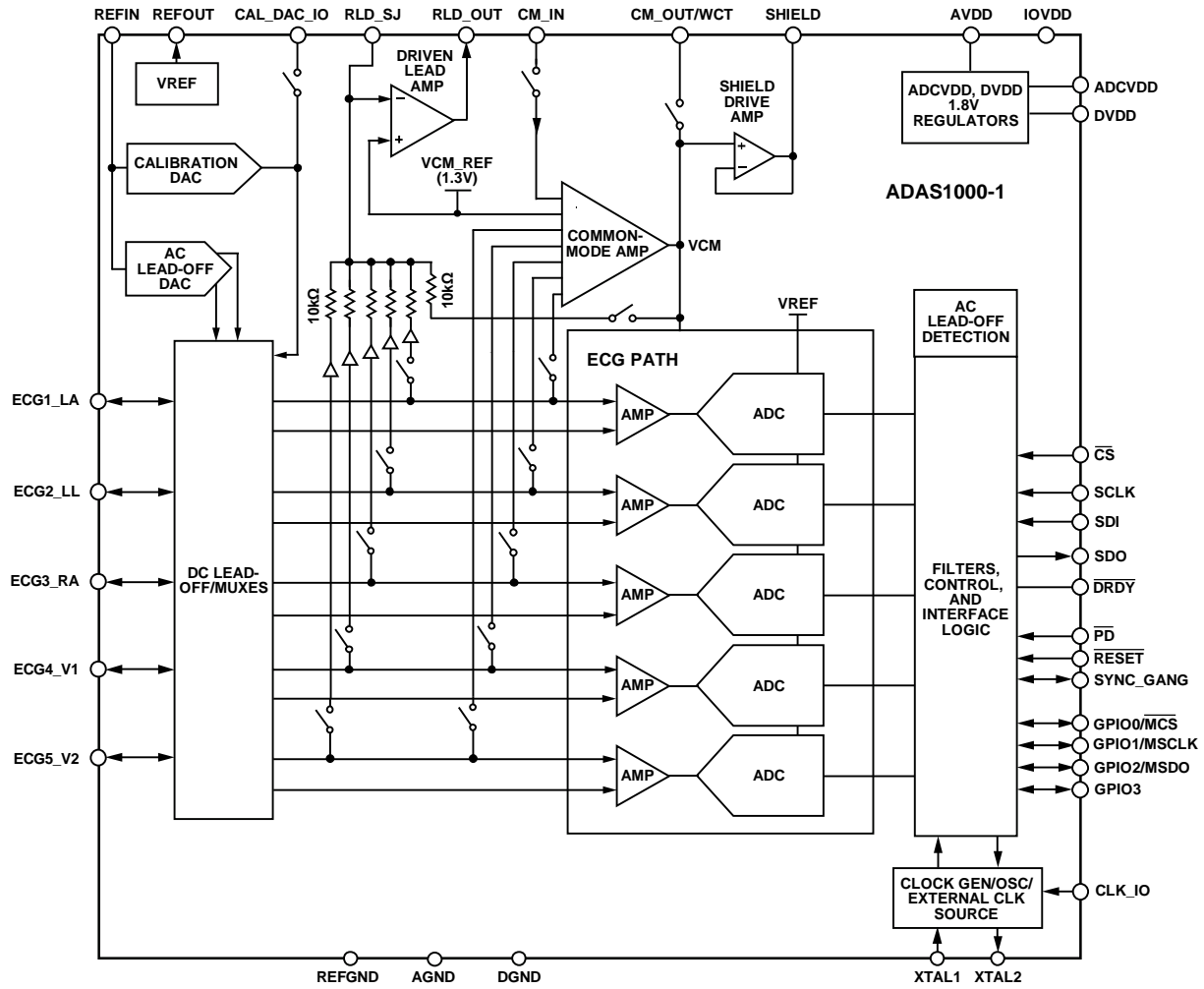

Figure 54. ADAS1000-1 Simplified Block Diagram

03860-012

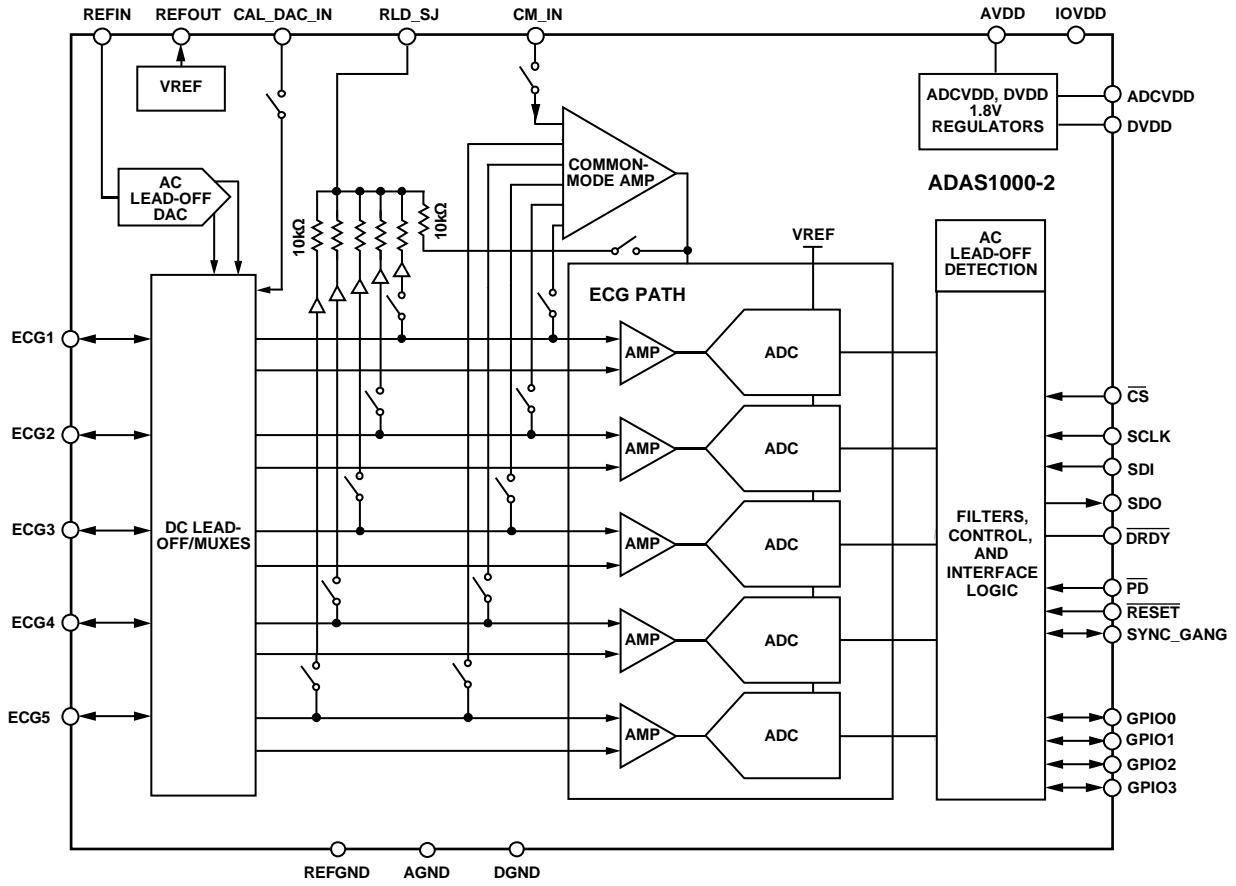

Figure 55. ADAS1000-2 Slave Device Simplified Block Diagram

09980-013

## ECG INPUTS—ELECTRODES/LEADS

The [ADAS1000/ADAS1000-1/ADAS1000-2](#) ECG product consists of 5 ECG inputs and a reference drive, RLD (right leg drive). In a typical 5-lead/vector application, four of the ECG inputs (ECG3\_RA, ECG1\_LA, ECG2\_LL, ECG4\_V1) would be used in addition to the RLD path. This leaves one spare ECG path (which could be used for other purposes, such as calibration or temperature measurement). Both V1 and V2 input channels can be used for alternative measurements if desired. When used in this way, the negative terminal of the input stage can be switched to the fixed internal VCM\_REF = 1.3 V; see details in Table 48.

In a 5-lead system, the [ADAS1000/ADAS1000-1/ADAS1000-2](#) can provide Lead I, Lead II, and Lead III data or electrode data directly via the serial interface at all frame rates. The other ECG leads can be calculated by the user's software from either the lead data or the electrode data provided by the [ADAS1000/](#)

[ADAS1000-1/ADAS1000-2](#). Note that in 128 kHz data rate, lead data is only available when configured in analog lead mode as shown in Figure 57. Digital lead mode is not available for this data rate.

A 12-lead (10-electrode) system can be achieved using one [ADAS1000](#) or [ADAS1000-1](#) device ganged together with one [ADAS1000-2](#) slave device as described in the Gang Mode Operation section. Here, 9 ECG electrodes and one RLD electrode achieve the 10 electrode system, again leaving one spare ECG channel that could be used for alternate purposes as suggested previously. In such a system, having nine dedicated electrodes benefits the user by delivering lead information based on electrode measurements and calculations rather than deriving leads from other lead measurements.

Table 10 outlines the calculation of the leads (vector) from the individual electrode measurements.

**Table 10. Lead Composition<sup>1</sup>**

	Lead Name	Composition	Equivalent
<a href="#">ADAS1000</a> or <a href="#">ADAS1000-1</a>	I	LA – RA	
	II	LL – RA	
	III	LL – LA	
	aVR <sup>2</sup>	RA – 0.5 × (LA + LL)	–0.5 × (I + II)
	aVL <sup>2</sup>	LA – 0.5 × (LL + RA)	0.5 × (I – III)
	aVF <sup>2</sup>	LL – 0.5 × (LA + RA)	0.5 × (II + III)
	V1'	V1 – 0.333 × (LA + RA + LL)	
	V2'	V2 – 0.333 × (LA + RA + LL)	
12 Leads Achieved by Adding <a href="#">ADAS1000-2</a> Slave	V3'	V3 – 0.333 × (LA + RA + LL)	
	V4'	V4 – 0.333 × (LA + RA + LL)	
	V5'	V5 – 0.333 × (LA + RA + LL)	
	V6'	V6 – 0.333 × (LA + RA + LL)	

<sup>1</sup> These lead compositions apply when the master [ADAS1000](#) device is configured into lead mode (analog lead mode or digital lead mode) with VCM = WCT = (RA + LA + LL)/3. When configured for 12-lead operation with a master and slave device, the VCM signal derived on the master device (CM\_OUT) is applied to the CM\_IN of the slave device. For correct operation of the slave device, the device must be configured in electrode mode (see the FRMCTL register in Table 35).

<sup>2</sup> These augmented leads are not calculated within the [ADAS1000](#), but can be derived in the host DSP/microcontroller/FPGA.

## ECG CHANNEL

The ECG channel consists of a programmable gain, low noise, differential preamplifier; a fixed gain anti-aliasing filter; buffers; and an ADC (see Figure 56). Each electrode input is routed to its PGA noninverting input. Internal switches allow the PGAs inverting inputs to be connected to other electrodes and/or the Wilson central terminal to provide differential analog processing (analog lead mode), to a computed average of some or all electrodes, or the internal 1.3 V common-mode reference (VCM\_REF). The latter two modes support digital lead mode (leads computed on-chip) and electrode mode (leads calculated off-chip). In all cases, the internal reference level is removed from the final lead data.

The ADAS1000/ADAS1000-1/ADAS1000-2 implementation uses a dc-coupled approach, which requires that the front end be biased to operate within the limited dynamic range imposed by the relatively low supply voltage. The right leg drive loop performs this function by forcing the electrical average of all selected electrodes to the internal 1.3 V level, VCM\_REF, maximizing each channel's available signal range.

All ECG channel amplifiers use chopping to minimize  $1/f$  noise contributions in the ECG band. The chopping frequency of  $\sim 250$  kHz is well above the bandwidth of any signals of interest. The 2-pole anti-aliasing filter has  $\sim 65$  kHz bandwidth to support digital pace detection while still providing greater than 80 dB of attenuation at the ADC's sample rate. The ADC itself is a 14-bit, 2 MHz SAR converter;  $1024 \times$  oversampling helps achieve the required system performance. The ADC's full-scale input range is  $2 \times V_{REF}$ , or 3.6 V, although the analog portion of the ECG channel limits the useful signal swing to about 2.8 V.

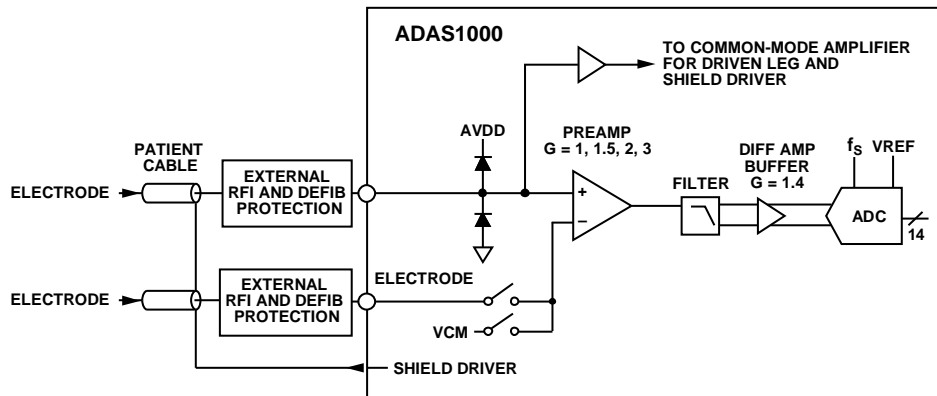

Figure 56. Simplified Schematic of a Single ECG Channel

**ELECTRODE/LEAD FORMATION AND INPUT STAGE CONFIGURATION**

The input stage of the ADAS1000/ADAS1000-1/ADAS1000-2 can be arranged in several different manners. The input amplifiers are differential amplifiers and can be configured to generate the leads in the analog domain, before the ADCs. In addition to this, the digital data can be configured to provide either electrode or lead format under user control as described in Table 35. This allows maximum flexibility of the input stage for a variety of applications.

**Analog Lead Configuration and Calculation**

Leads are configured in the analog input stage when CHCONFIG = 1, as shown in Figure 58. This uses a traditional in-amp structure where lead formation is performed prior to digitization, with WCT created using the common-mode amplifier. While this results in the inversion of Lead II in the analog domain, this is digitally corrected so output data have the proper polarity.

**Digital Lead Configuration and Calculation**

When the ADAS1000/ADAS1000-1/ADAS1000-2 are configured for digital lead mode (see the FRMCTL register, 0x0A[4], Table 35), the digital core will calculate each lead from the electrode signals. This is straightforward for Lead I/Lead II/Lead III. Calculating V1' and V2' requires WCT, which is also computed internally for this purpose. This mode ignores the common-mode configuration specified in the CMREFCTL register (0x05). Digital lead calculation is only available in 2 kHz and 16k Hz data rates.

**Single-Ended Input Electrode**

In this mode, the electrode data are digitized relative to the common-mode signal, VCM, which can be arranged to be any combination of the contributing ECG electrodes. Common-mode generation is controlled by the CMREFCTL register as described in Table 30.

**Common Electrode Configuration**

In this mode, all electrodes are digitized relative to a common electrode, for example, RA. Standard leads must be calculated by post processing the output data of the ADAS1000/ADAS1000-1/ADAS1000-2. See Figure 60.

0x0A [4] <sup>1</sup>	0x01 [10] <sup>2</sup>	0x05 [8] <sup>3</sup>	MODE	WORD1	WORD2	WORD3	WORD4	WORD5
0	0	0	SINGLE-ENDED INPUT, DIGITALLY CALCULATED LEADS	LEAD I (LA - RA)	LEAD II (LL - RA)	LEAD III (LL - LA)	V1' (V1 - WCT <sup>4</sup> )	V2' (V2 - WCT <sup>4</sup> )
0	0	1	COMMON ELECTRODE (CE) LEADS (HERE RA ELECTRODE IS CONNECTED TO THE CE ELECTRODE (CM_IN) AND V3 IS ON ECG3 INPUT) <sup>5</sup>	LEAD I (LA - RA)	LEAD II (LL - RA)	V3' $(V3 - RA) - (LA - RA) - (LL - RA)$ 3	V1' $(V1 - RA) - (LA - RA) + (LL - RA)$ 3	V2' $(V2 - RA) - (LA - RA) + (LL - RA)$ 3
0	1	0	ANALOG LEADS <sup>6</sup>	LEAD I (LA - RA)	LEAD II (LL - RA)	LEAD III (LL - LA)	V1' (V1 - VCM)	V2' (V2 - VCM)
1	0	0	SINGLE-ENDED INPUT ELECTRODE RELATIVE TO VCM <sup>7</sup>	LA - VCM	LL - VCM	RA - VCM	V1 - VCM	V2 - VCM
1	0	1	LEADS FORMED RELATIVE TO A COMMON ELECTRODE (CE) <sup>5</sup>	LA - CE	LL - CE	V1 - CE	V2 - CE	V3 - CE

<sup>1</sup> REGISTER FRMCTL, BIT DATAFMT: 0 = LEAD/VECTOR MODE; 1 = ELECTRODE MODE.  
<sup>2</sup> REGISTER ECGCTL, BIT CHCONFIG: 0 = SINGLE ENDED INPUT (DIGITAL LEAD MODE OR ELECTRODE MODE); 1 = DIFFERENTIAL INPUT (ANALOG LEAD MODE).  
<sup>3</sup> REGISTER CMREFCTL, BIT CEREFEN: 0 = CE DISABLED; 1 = CE ENABLED.  
<sup>4</sup> WILSON CENTRAL TERMINAL (WCT) = (RA + LA + LL)/3, THIS IS A DIGITALLY CALCULATED WCT BASED ON THE RA, LA, LL MEASUREMENTS.  
<sup>5</sup> COMMON ELECTRODE MODE AS SHOWN IN FIGURE 60.  
<sup>6</sup> ANALOG LEAD MODE AS SHOWN IN FIGURE 58.  
<sup>7</sup> SINGLE-ENDED INPUT ELECTRODE MODE AS SHOWN IN FIGURE 59.

Figure 57. Electrode and Lead Configurations

008660-061

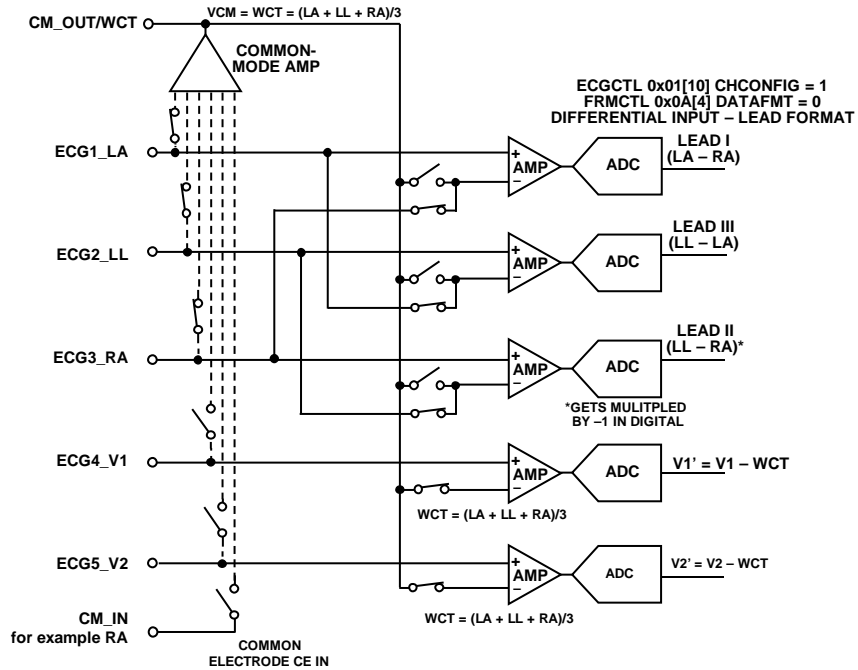

Figure 58. Flexible Front-End Configuration—Showing Analog Lead Mode Configuration Relative to Wilson Central Terminal (WCT)

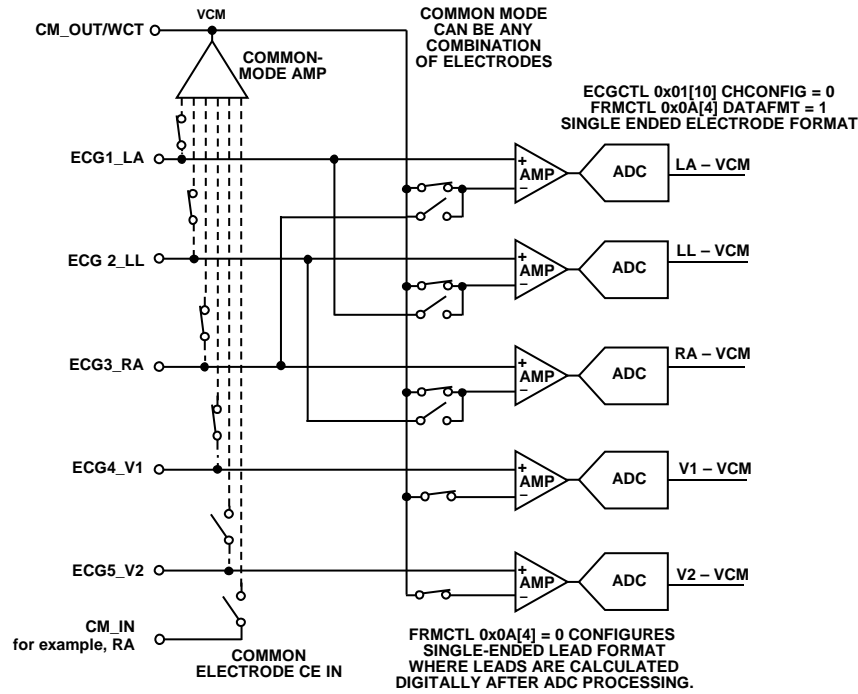
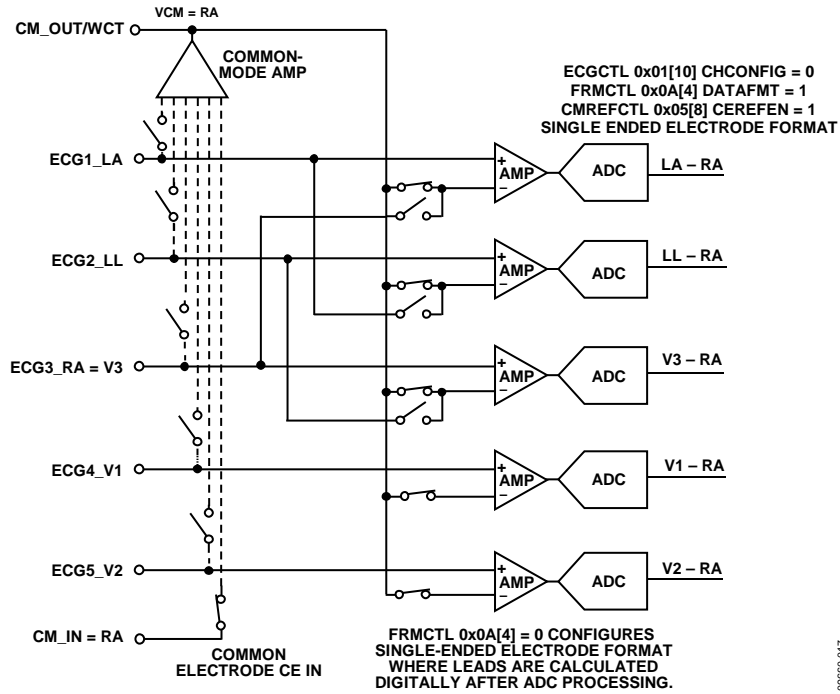

Figure 59. Flexible Front-End Configuration—Showing Single-Ended Electrode Configuration



09680-017

Figure 60. Flexible Front-End Configuration—Showing Common Electrode Configuration



**DEFIBRILLATOR PROTECTION**

The ADAS1000/ADAS1000-1/ADAS1000-2 do not include defibrillation protection on chip. Any defibrillation protection required by the application requires external components. Figure 61 and Figure 62 show examples of external defibrillation protection, which is required on each ECG channel, in the RLD path and in the CM\_IN path if using the CE input mode. Note that, in both cases, the total ECG path resistance is assumed to be 5 kΩ. The 22 MΩ resistors shown connected to RLD are optional and used to provide a safe termination voltage for an open ECG electrode; they may be larger in value. Note that, if using these resistors, the dc lead-off feature works best with the highest current setting.

**ESIS FILTERING**

The ADAS1000/ADAS1000-1/ADAS1000-2 do not include electro-surgical interference suppression (ESIS) protection on chip. Any ESIS protection required by the application requires external components.

**ECG PATH INPUT MULTIPLEXING**

As shown in Figure 63, signal paths for numerous functions are provided on each ECG channel (except respiration, which only connect to the ECG1\_LA, ECG2\_LL, and ECG3\_RA pins). Note that the channel enable switch occurs after the RLD amplifier connection, thus allowing the RLD to be connected (re-directed into any one of the ECG paths). The CM\_IN path is treated the same as the ECG signals.

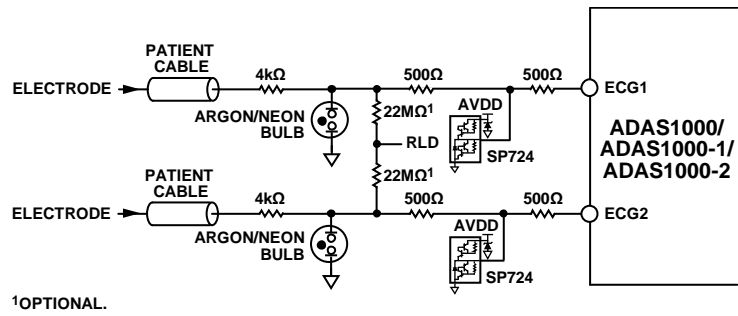

<sup>1</sup>OPTIONAL.

Figure 61. Possible Defibrillation Protection on ECG Paths Using Neon Bulbs

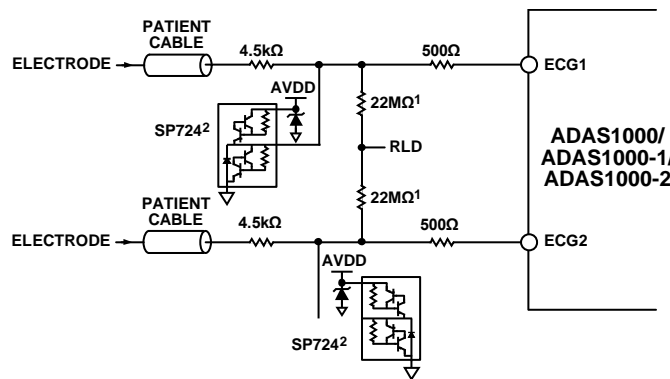

<sup>1</sup>OPTIONAL.

<sup>2</sup>TWO SP724 CHANNELS PER ELECTRODE MAY PROVIDE BEST PROTECTION.

Figure 62. Possible Defibrillation Protection on ECG Paths Using Diode Protection

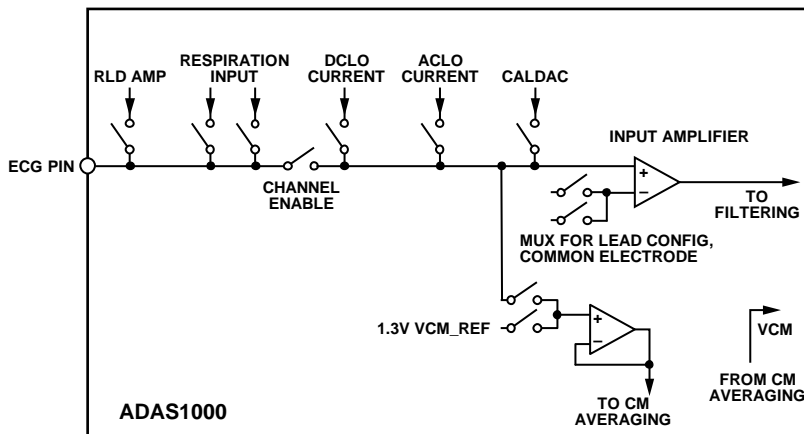

Figure 63. Typical ECG Channel Input Multiplexing

**COMMON-MODE SELECTION AND AVERAGING**

The common-mode signal can be derived from any combination of one or more electrode channel inputs, the fixed internal common-mode voltage reference, VCM\_REF, or an external source connected to the CM\_IN pin. One use of the latter arrangement is in gang mode where the master device creates the Wilson central terminal for the slave device(s). The fixed reference option is useful when measuring the calibration DAC test tone signals or while attaching electrodes to the patient, where it allows a usable signal to be obtained from just two electrodes.

The flexible common-mode generation allows complete user control over the contributing channels. It is similar to, but independent of, circuitry that creates the right leg drive (RLD) signal. Figure 64 shows a simplified version of the

common-mode block. If the physical connection to each electrode is buffered, these buffers are omitted for clarity.

There are several restrictions on the use of the switches:

- If SW1 is closed, SW7 must be open.
- If SW1 is open, at least one electrode switch (SW2 to SW7) must be closed.
- SW7 can be closed only when SW2 to SW6 are open, so that the 1.3 V VCM\_REF gets summed in only when all ECG channels are disconnected.

The CM\_OUT output is not intended to supply current or drive resistive loads, and its accuracy is degraded if it is used to drive anything other than the slave ADAS1000-2 devices. An external buffer is required if there is any loading on the CM\_OUT pin.

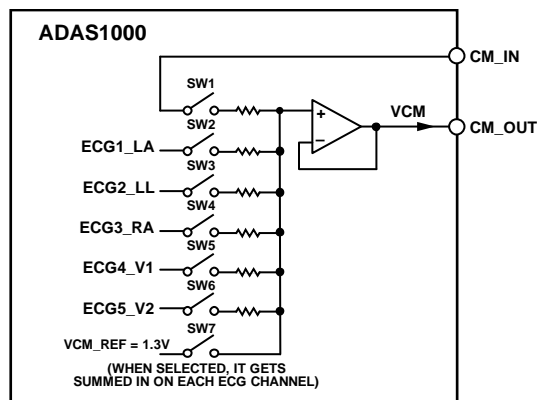

Figure 64. Common-Mode Generation Block

Table 11. Truth Table for Common-Mode Selection

ECGCTL Address 0x01 <sup>1</sup>	CMREFCTL Address 0x05 <sup>2</sup>							On Switch	Description
	PWREN	DRVCM	EXTCM	LACM	LLCM	RACM	V1CM		
0	X	X	X	X	X	X	X	X	Powered down, paths disconnected
1	X	0	0	0	0	0	0	0	Internal VCM_REF = 1.3 V is selected
1	0	0	1	0	0	0	0	0	Internal CM selection: LA contributes to VCM
1	0	0	1	1	0	0	0	0	Internal CM selection: LA and LL contribute to VCM
1	0	0	1	1	1	0	0	0	Internal CM selection: LA, LL, and RA contribute to VCM (WCT)
.	.	.	.	.	.	.	.	.	.
1	X	1	X	X	X	X	X	X	External VCM selected

<sup>1</sup> See Table 26.

<sup>2</sup> See Table 30.

**WILSON CENTRAL TERMINAL (WCT)**

The flexibility of the common-mode selection averaging allows the user to achieve a Wilson central terminal voltage from the ECG1\_LA, ECG2\_LL, ECG3\_RA electrodes.

**RIGHT LEG DRIVE/REFERENCE DRIVE**

The right leg drive amplifier or reference amplifier is used as part of a feedback loop to force the patient's common-mode voltage close to the internal 1.3 V reference level (VCM\_REF) of the ADAS1000/ADAS1000-1/ADAS1000-2. This centers all the electrode inputs relative to the input span, providing maximum input dynamic range. It also helps to reject noise and interference from external sources such as fluorescent lights or other patient-connected instruments, and absorbs the dc or ac lead-off currents injected on the ECG electrodes.

The RLD amplifier can be used in a variety of ways as shown in Figure 65. Its input can be taken from the CM\_OUT signal using an external resistor. Alternatively, some or all of the electrode signals can be combined using the internal switches.

The DC gain of the RLD amplifier is set by the ratio of the external feedback resistor (RFB) to the effective input resistor, which can be set by an external resistor, or alternatively, a function of the number of selected electrodes as configured in the CMREFCTL register (see Table 30). In a typical case, using the internal resistors for R<sub>IN</sub>, all active electrodes would be used to derive the right leg drive, resulting in a 2 kΩ effective input resistor. Achieving a typical dc gain of 40 dB would thus require a 200 kΩ feedback resistor.

The dynamics and stability of the RLD loop depend on the chosen dc gain and the resistance and capacitance of the patient cabling. In general, loop compensation using external components is required, and must be determined experimentally for any given instrument design and cable set.

In some cases, adding lead compensation will prove necessary, while in others lag compensation may be more appropriate. The RLD amplifier's summing junction is brought out to a package pin (RLD\_SJ) to facilitate compensation.

The RLD amplifier's short circuit current capability exceeds regulatory limits. A patient protection resistor is required to achieve compliance.

Within the RLD block, there is lead-off comparator circuitry that monitors the RLD amplifier output to determine whether the patient feedback loop is closed. An open-loop condition, typically the result of the right leg electrode (RLD\_OUT) becoming detached, tends to drive the amplifier's output low. This type of fault is flagged in the header word (see Table 52), allowing the system software to take action by notifying the user, redirecting the reference drive to another electrode via the internal switches of the ADAS1000/ADAS1000-1/ADAS1000-2, or both. The detection circuitry is local to the RLD amplifier and remains functional with a redirected reference drive. Table 30 provides details on reference drive redirection.

While reference drive redirection may be useful in the event that the right leg electrode cannot be reattached, some precautions must be observed. Most important is the need for a patient protection resistor. Because this is an external resistor, it does not follow the redirected reference drive; some provision for continued patient protection is needed external to the ADAS1000/ADAS1000-1/ADAS1000-2. Any additional resistance in the ECG paths will certainly interfere with respiration measurement and may also result in an increase in noise and decrease in CMRR.

The RLD amplifier is designed to stably drive a maximum capacitance of 5 nF based on the gain configuration (see Figure 65) and assuming a 330 kΩ patient protection resistor.

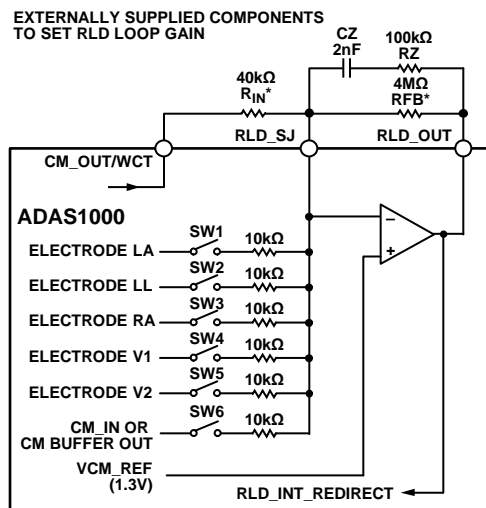

\*EXTERNAL RESISTOR R<sub>IN</sub> IS OPTIONAL. IF DRIVING RLD FROM THE ELECTRODE PATHS, THEN THE SERIES RESISTANCE WILL CONTRIBUTE TO THE R<sub>IN</sub> IMPEDANCE. WHERE SW1 TO SW5 ARE CLOSED, R<sub>IN</sub> = 2kΩ. RFB SHOULD BE CHOSEN ACCORDINGLY FOR DESIRED RLD LOOP GAIN.

Figure 65. Right Leg Drive—Possible External Component Configuration

## CALIBRATION DAC

Within the [ADAS1000/ADAS1000-1](#), there are a number of calibration features.

The 10-bit calibration DAC can be used to correct channel gain errors (to ensure channel matching) or to provide several test tones. The options are as follows:

- DC voltage output (range: 0.3 V to 2.7 V). The DAC transfer function for dc voltage output is

$$0.3 \text{ V} + \left( 2.4 \text{ V} \times \frac{\text{code}}{(2^{10} - 1)} \right)$$

- 1 mV p-p sine wave of 10 Hz or 150 Hz
- 1 mV 1 Hz square wave

Internal switching allows the calibration DAC signals to be routed to the input of each ECG channel (see Figure 63). Alternatively, it can be driven out from the CAL\_DAC\_IO pin, enabling measurement and correction for external error sources in the entire ECG signal chain and/or for use as an input to the [ADAS1000-2](#) companion chip calibration input.

To ensure a successful update of the calibration DAC (see Table 34), the host controller must issue four additional SCLK cycles after writing the new calibration DAC register word.

## GAIN CALIBRATION

The gain for each ECG channel can be adjusted to correct for gain mismatches between channels. Factory trimmed gain correction coefficients are stored in nonvolatile memory on-chip for GAIN 0, GAIN 1, and GAIN 2; there is no factory calibration for GAIN 3. The default gain values can be overwritten by user gain correction coefficients, which are stored in volatile memory and available by addressing the appropriate gain control registers (see Table 49). The gain calibration applies to the ECG data available on the standard interface and applies to all data rates.

## LEAD-OFF DETECTION

An ECG system must be able to detect if an electrode is no longer connected to the patient. The [ADAS1000/ADAS1000-1/ADAS1000-2](#) support two methods of lead-off detection: either ac or dc lead-off detection. The two systems are independent and can be used singly or together under the control of the serial interface (see Table 27).

For both ac and dc lead-off detection, the upper and lower threshold voltages are programmable via Table 37 and Table 38. Note that these programmed thresholds voltage vary with the ECG channel gain. The threshold voltages are not affected by the current level that is programmed.

DC lead-off detection uses fixed gain-independent upper and lower threshold voltages. AC lead-off detection offers user-programmable thresholds; because the detection is performed digitally, it may be necessary to adjust the thresholds, depending on the selected ECG channel gain. In

either case, all active channels use the same detection thresholds.

A lead-off event sets a flag in the frame header word (see Table 52). Identification of which electrode is off is available as part of the data frame or as a register read from the lead-off status register (Register LOFF, see Table 45). In the case of ac lead-off, information about the amplitude of the lead-off signal(s) can be read back through the serial interface (see Table 50).

### DC Lead-Off Detection

This method injects a small programmable dc current into each input electrode. When an electrode is properly connected, the current flows into the right leg (RLD\_OUT) and produces a minimal voltage shift. If an electrode is off, the current charges that pin's capacitance, causing the voltage at the pin to float positive and create a large voltage change that is detected by the comparators in each channel.

The dc lead-off detection current can be programmed via the serial interface. Typical currents range from 10 nA to 70 nA in 10 nA steps.

The propagation delay for detecting a dc lead-off event depends on the cable capacitance and the programmed current. It is approximately

$$\text{Delay} = \text{Voltage} \times \text{Cable Capacitance} / \text{Programmed Current}$$

For example:

$$\text{Delay} = 1.2 \text{ V} \times (200 \text{ pF} / 70 \text{ nA}) = 3.43 \text{ ms}$$

### AC Lead-Off Detection

The alternative method of sensing if the electrodes are connected to the patient is based on injecting ac currents into each channel and measuring the amplitudes of the resulting voltages. The system uses a fixed carrier frequency slightly above 2 kHz, high enough to be removed by the [ADAS1000/ADAS1000-1/ADAS1000-2](#) on-chip digital filters without introducing phase or amplitude artifacts into the ECG signal.

The polarity of the ac lead-off signal can be configured on a per-electrode basis. All electrodes can be driven in phase, or some can be driven with reversed polarity to minimize the total injected ac current. Drive amplitude is also programmable. The propagation delay for detecting an ac lead-off event is <10 ms.

Note that the ac lead-off function is disabled when the calibration DAC is enabled.

## SHIELD DRIVER

The shield drive amplifier is a unity gain amplifier. Its purpose is to drive the shield of the ECG cables. For power consumption purposes, it can be disabled if not in use. Note that, the SHIELD pin is shared with the respiration pin function, where it can be muxed to be one of the pins for external capacitor connection. If the pin is being used for the respiration feature, the shield function is not available. In this case, if the application requires

a shield drive, an external amplifier connected to the CM\_OUT pin can be used.

**RESPIRATION (ADAS1000 MODEL ONLY)**

The respiration measurement is performed by driving a high frequency (programmable from 46.5 kHz to 64 kHz) differential current into two electrodes; the resulting impedance variation caused by breathing causes the differential voltage to vary at the respiration rate. The signal is ac-coupled onto the patient. The acquired signal is AM, with a carrier at the driving frequency and a shallow modulation envelope at the respiration frequency. The modulation depth is greatly reduced by the resistance of the customer-supplied RFI and ESIS protection filters, in addition to the impedance of the cable and the electrode to skin interface (see Table 12). The goal is to measure small ohm variation to sub ohm resolution in the presence of large series resistance. The circuit itself consists of a respiration DAC that drives the ac-coupled current at a programmable frequency onto the chosen pair of electrodes. The resulting variation in voltage is amplified, filtered, and synchronously demodulated in the digital domain; what results is a digital signal that represents the total thoracic or respiration impedance, including cable and electrode contributions. While it is heavily low-pass filtered on-chip, the user is required to further process it to extract the envelope and perform the peak detection needed to establish breathing (or lack thereof).

Respiration measurement is available on one of the leads (Lead I, Lead II, or Lead III) or on an external path via a pair of dedicated pins (EXT\_RESP\_LA, EXT\_RESP\_RA, or EXT\_RESP\_LL).

Only one lead measurement can be made at one time. The respiration measurement path is not suited for use as additional ECG measurements because the internal configuration and demodulation do not align with an ECG measurement; however, the EXT\_RESP\_LA, EXT\_RESP\_RA, or EXT\_RESP\_LL paths can be multiplexed into one of the ECG ADC paths, if required, as discussed in the Extend Switch On Respiration Paths section.

**Internal Respiration Capacitors**

The internal respiration function uses an internal RC network (5 kΩ/100 pF), and this circuit is capable of 200 mΩ resolution (with up to 5 kΩ total path and cable impedance). The current is ac-coupled onto the same pins that the measurement is sensed back on. Figure 66 shows the measurement on Lead I, but, similarly, the measurement can be configured to measure on either Lead II or Lead III. The internal capacitor mode requires no external capacitors and produces currents of ~64 μA p-p amplitude when configured for maximum amplitude setting (±1V) through the RESPCTRL register (see Table 28).

**Table 12. Maximum Allowable Cable and Thoracic Loading**

Cable Resistance	Cable Capacitance
$R < 1 \text{ k}\Omega$	$C < 1200 \text{ pF}$
$1 \text{ k}\Omega < R < 2.5 \text{ k}\Omega$	$C < 400 \text{ pF}$
$2.5 \text{ k}\Omega < R < 5 \text{ k}\Omega$	$C < 200 \text{ pF}$
$R_{\text{thoracic}} < 2 \text{ k}\Omega$	

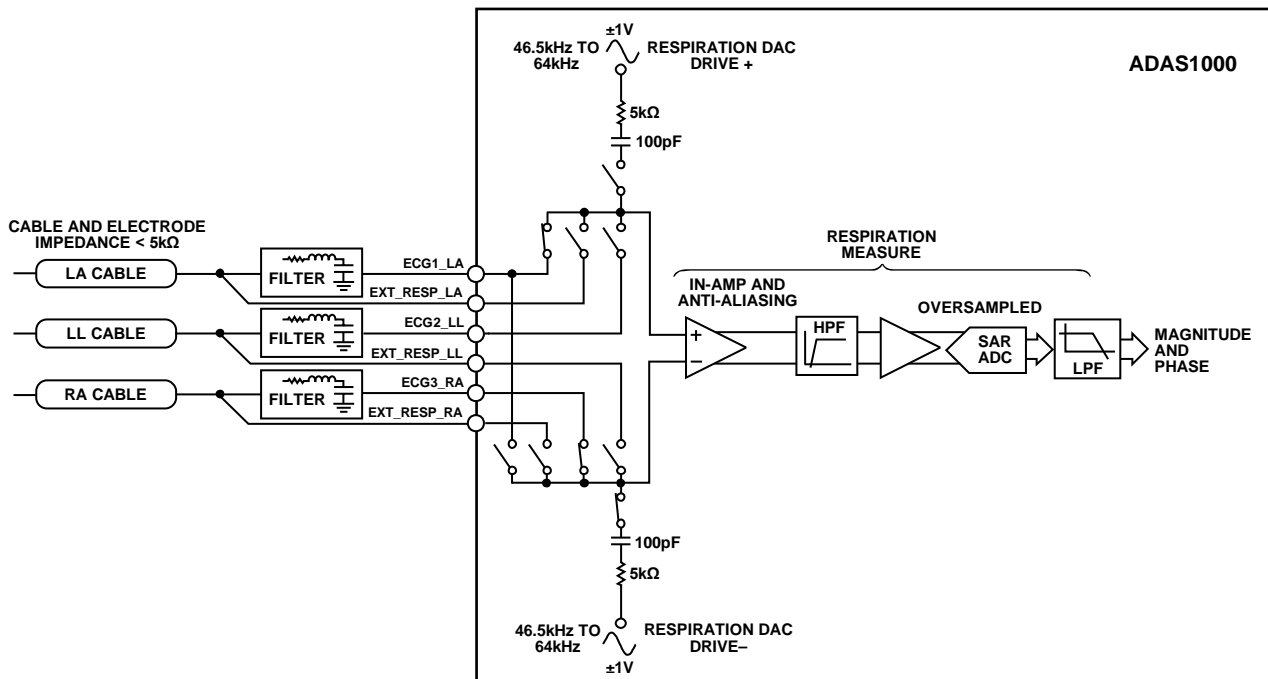

Figure 66. Simplified Respiration Block Diagram

**External Respiration Path**

The EXT\_RESP\_xx pins are provided for use either with the ECG electrode cables or, alternatively, with a dedicated external sensor independent of the ECG electrode path. Additionally, the EXT\_RESP\_xx pins are provided such that the user can measure the respiration signal at the patient side of the RFI/ESIS protection filters. In this case, the user must take precautions to protect the EXT\_RESP\_xx pins from any signals applied that are in excess of the operating voltage range.

**External Respiration Capacitors**

If necessary, the ADAS1000 allows the user to connect external capacitors into the respiration circuit to achieve higher resolution ( $<200\text{ m}\Omega$ ). This level of resolution requires that the cable impedance be  $\leq 1\text{ k}\Omega$ . The diagram in Figure 67 shows the connections at RESPDAC\_xx paths for the extended respiration configuration. Again, the EXT\_RESP\_xx paths can be connected at the patient side of any filtering circuit; however, the user must provide protection for these pins. While this external capacitor mode requires external components, it can deliver a larger signal-to-noise ratio. Note again that respiration can be measured on only one lead (at one time); therefore, only one pair of external respiration paths (and external capacitors) may be required.

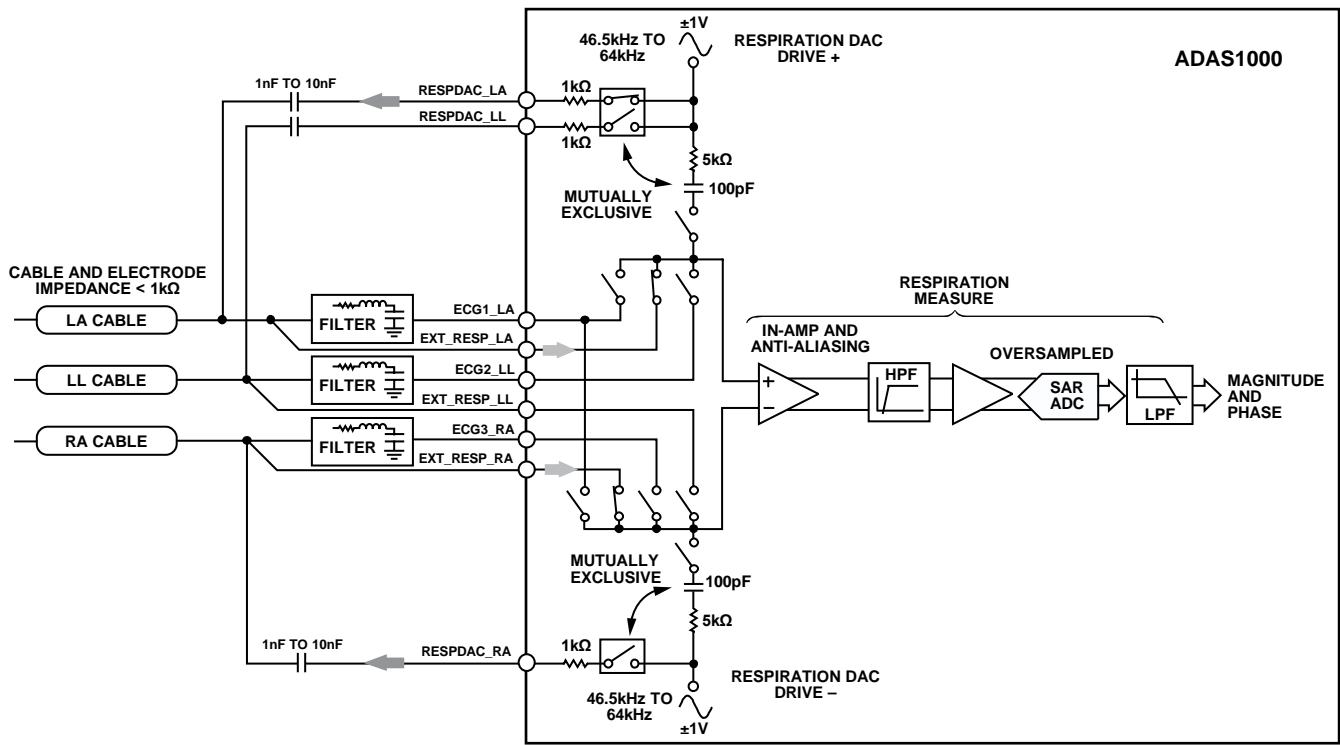

Figure 67. Respiration Measurement Using External Capacitor

08860-024

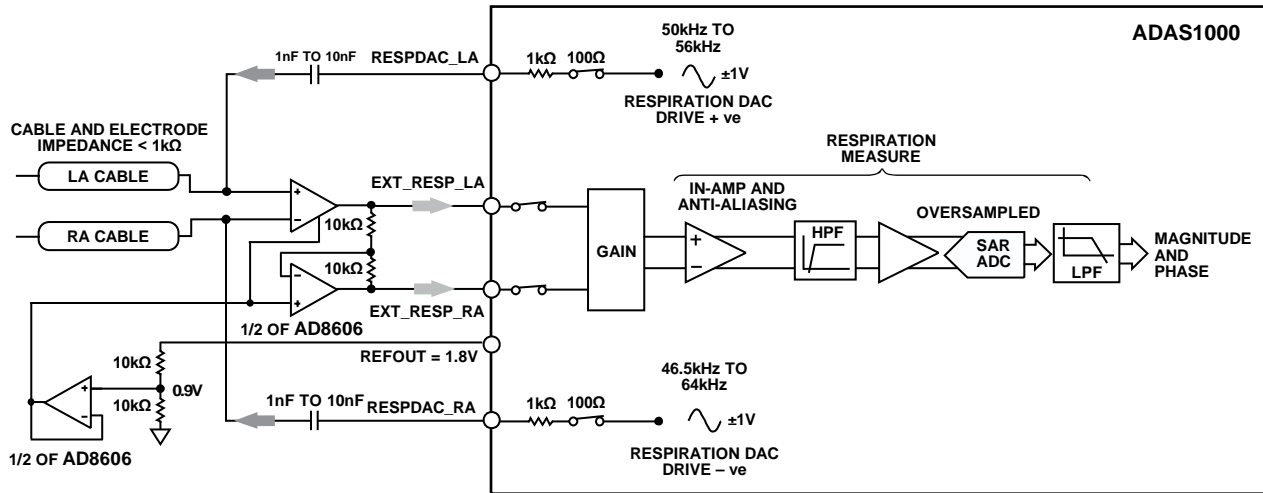

Figure 68. Respiration Using External Capacitor and External Amplifiers

08860-025

If required, further improvements in respiration performance may be possible with the use of an instrumentation amplifier and op amp external to the ADAS1000. The instrumentation amplifier must have sufficiently low noise performance to meet the target performance levels. This mode uses the external capacitor mode configuration and is shown in Figure 68. Bit 14 of the RESPCTL register (Table 28) allows the user to bypass the on-chip amplifier when using an external instrumentation amplifier.

**Respiration Carrier**

In applications where an external signal generator is used to develop a respiration carrier signal, that external signal source can be synchronized to the internal carrier using the signal available on GPIO3 when Bit 7, RESPEXTSEL, is enabled in the respiration control register (see Table 28).

**EVALUATING RESPIRATION PERFORMANCE**

ECG simulators offer a convenient means of studying the ADAS1000’s performance. While many simulators offer a variable-resistance respiration capability, care must be taken when using this feature.

Some simulators use electrically programmable resistors, often referred to as digiPOTs, to create the time-varying resistance to be measured by the respiration function. The capacitances at the digitPOT’s terminals are often unequal and code-dependent, and these unbalanced capacitances can give rise to unexpectedly large or small results on different leads for the same programmed resistance variation. Best results are obtained with a purpose-built fixture that carefully balances the capacitance presented to each ECG electrode.

**EXTEND SWITCH ON RESPIRATION PATHS**

There is additional multiplexing on the external respiration inputs to allow them to serve as additional electrode inputs to the existing five ECG ADC channels. This approach allows a user to configure eight electrode inputs; however, it is not intended as a true 8-channel/12-lead solution. Time overheads will be required to reconfigure the multiplexer arrangement using the serial interface in addition to filter the latency as described in Table 14.

The user has full control over the SW1/SW2/SW3 configuration as outlined in Table 48.

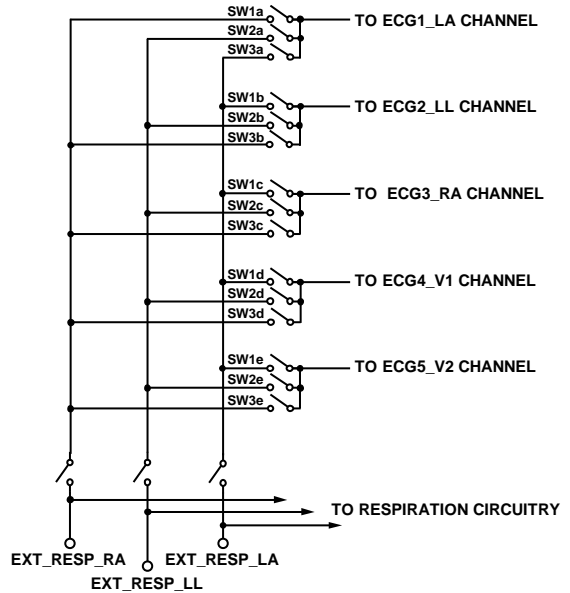

Figure 69. Alternative Use of the Respiration Paths

08860-032



**PACING ARTIFACT DETECTION FUNCTION  
(ADAS1000 ONLY)**

The pacing artifact validation function qualifies potential pacing artifacts and measures the width and amplitude of valid pulses. These parameters are stored in and available from any of the pace data registers (Address 0x1A, Address 0x3A to Address 0x3C). This function runs in parallel with the ECG channels. Digital detection is performed using a state machine operating on the 128 kHz 16-bit data from the ECG decimation chain. The main ECG signals are further decimated before appearing in the 2 kHz output stream so that detected pace signals are not perfectly time-aligned with fully-filtered ECG data. This time difference is deterministic and may be compensated for.

The pacing artifact validation function can detect and measure pacing artifacts with widths from 100 μs to 2 ms and with amplitudes of <400 μV to >1000 mV. Its filters are designed to reject heartbeat, noise, and minute ventilation pulses. The flowchart for the pace detection algorithm is shown in Figure 70.

The ADAS1000 pace algorithm can operate with the ac lead-off and respiration impedance measurement circuitry enabled.

Once a valid pace has been detected in the assigned leads, the pace-detected flags appear in the header word (see Table 52) at the start of the packet of ECG words. These bits indicate that a pace was qualified. Further information on height and width of pace is available by reading the contents of Address 0x1A (Register PACEDATA, see Table 42). This word can be included in the ECG data packet/frame as dictated by the frame control register (see Table 35). The data available in the PACEDATA register is limited to seven bits total for width and height information; therefore, if more resolution is required on the pace height and width, this is available by issuing read commands of the PACExDATA registers (Address 0x3A to Address 0x3C) as shown in Table 51.

Some users may not wish to use three pace leads for detection. In this case, Lead II would be the vector of choice because this lead is likely to display the best pacing artifact. The other two pace instances can be disabled if not in use.

The on-chip filtering contributes some delay to the pace signal (see the Pace Latency section).

**Choice of Leads**

Three identical state machines are available and can be configured to run on up to three of four possible leads (Lead I, Lead II, Lead III, and aVF) for pacing artifact detection. All necessary lead calculations are performed internally and are independent of ECG channel settings for output data rate, low-pass filter cutoff, and mode (electrode, analog lead, common electrode). These calculations take into account the available front-end configurations as detailed in Table 13.

The pace detection algorithm searches for pulses by analyzing samples in the 128 kHz ECG data stream. The algorithm searches for an edge, a peak, and a falling edge as defined by values in the PACEEDGETH, PACEAMPTH, and PACELVLTH registers, along with fixed width qualifiers. The post-reset default register values can be overwritten via the SPI bus, and different values can be used for each of the three pace detection state machines.

The first step in pace detection is to search the data stream for a valid leading edge. Once a candidate edge has been detected, the algorithm begins searching for a second, opposite-polarity edge that meets with pulse width criteria and passes the (optional) noise filters. Only those pulses meeting all the criteria are flagged as valid pace pulses. Detection of a valid pace pulse sets the flag(s) in the frame header register and stores amplitude and width information in the PACEDATA register (Address 0x1A; see Table 42). The pace algorithm looks for a negative or positive pulse.

**Table 13. Pace Lead Calculation**

0x01 [10] <sup>1</sup>	0x05 [8] <sup>2</sup>	Configuration	0x04 [8:3] <sup>3</sup>			
			00 Lead I (LA – RA)	01 Lead II (LL – RA)	10 Lead III (LL – LA)	11 aVF (Lead II + Lead III)/2
0	0	Digital leads	LA – RA CH1 – CH3	LL – RA CH2 – CH3	LL – LA CH2 – CH1	LL – (LA + RA)/2 CH2 – (CH1 + CH3)/2
0	1	Common electrode leads	Lead I CH1	Lead II CH2	Lead II – Lead I CH2 – CH1	lead II – 0.5 × Lead I CH2 – 0.5 × CH1
1	X	Analog leads	Lead I CH1	Lead II –CH3	Lead III CH2	Lead II – 0.5 × Lead I – CH3 – 0.5 × CH1

<sup>1</sup> Register ECGCTL, Bit CHCONFIG, see Table 26.  
<sup>2</sup> Register CMREFCTL, Bit CEREFEN, see Table 30.  
<sup>3</sup> Register PACECTL, Bit PACExSEL [1:0], see Table 29.



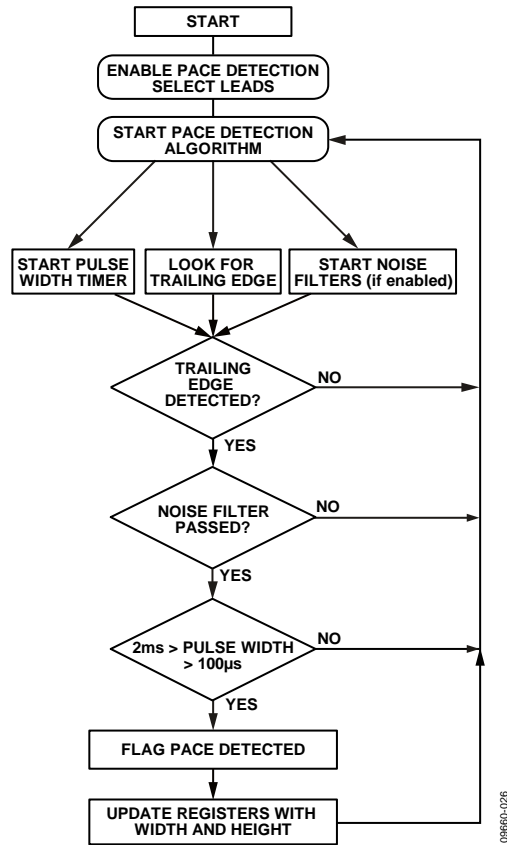

Figure 70. Overview of Pace Algorithm

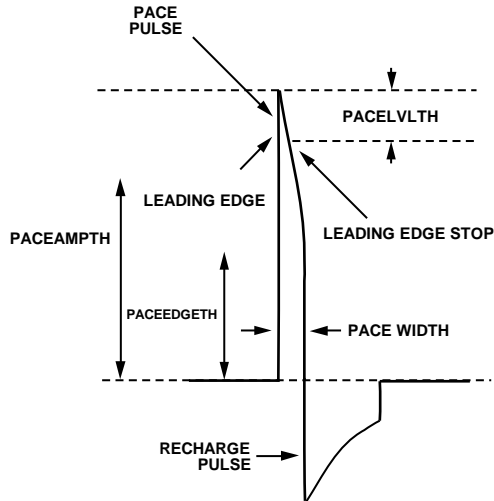

Figure 71. Typical Pace Signal

**Pace Amplitude Threshold**

This register (Address 0x07, see Table 32) can be used to set the minimum valid pace pulse amplitude:

$$PACEAMPTH \text{ setting} = \frac{N \times VREF}{GAIN \times 2^{16}}, \text{ (corresponds to a range of } 20 \mu\text{V to } 5 \text{ mV in the } \times 1.4 \text{ gain setting (GAIN } 0))$$

where:

$N = 0$  to 255 (8 bits), register default  $N = 0x24$ , (PACEAMPTH = 706  $\mu\text{V}$  in the  $\times 1.4$  gain setting)

$GAIN = 1.4, 2.1, 2.8, \text{ or } 4.2$  (programmable).

$VREF = 1.8 \text{ V}$ .

This level would typically be set to be the minimum expected pace amplitude.

For best results under most operating conditions for both biventricular and unipolar pacing, it is suggested to set the pace amplitude threshold to a value of approximately 700  $\mu\text{V}$  to 1 mV. It is not recommended to set the threshold below 250  $\mu\text{V}$  to avoid ambient noise from the patient. The amplitude may need to be adjusted much higher than 1 mV when other medical devices are connected to the patient.

**Pace Edge Threshold**

This programmable level (Address 0x0E, see Table 39) is used to find a leading edge, signifying the start of a pace pulse:

$$PACEEDGE setting = \frac{N \times VREF}{GAIN \times 2^{16}} \text{ (corresponds to a range of } 20 \mu\text{V to } 5 \text{ mV in the } \times 1.4 \text{ gain setting)}$$

where:

If  $N = 0$ , PACEEDGE = PACEAMPTH/2, then  $N = 0$  to 255 (8 bits).

$GAIN = 1.4, 2.1, 2.8 \text{ or } 4.2$  (programmable).

$VREF = 1.8 \text{ V}$ .

**Pace Level Threshold**

This programmable level (Address 0x0F, see Table 40) is used to find the leading edge peak:

$$PACELVLTH \text{ setting} = \frac{N \times VREF}{GAIN \times 2^{16}}, \text{ signed (FF} = -1, 01 = +1), \text{ default} = 0$$

where:

$N = 0$  to 255 (8 bits).

$GAIN = 1.4, 2.1, 2.8 \text{ or } 4.2$  (programmable).

$VREF = 1.8 \text{ V}$ .

**Pace Validation Filter 1**

This filter is used to reject sub threshold pulses such as minute ventilation (MV) pulses and inductive coupled implantable telemetry systems. It is typically enabled and is controlled via the PACECTL register, Bit 9 (see Table 29) register. Filter 1 applies to all leads enabled for pace detection.

**Pace Validation Filter 2**

This filter is also used to reject sub threshold pulses such as MV pulses and inductive implantable telemetry systems. It is normally enabled and is controlled via the PACECTL register, Bit 10 (see Table 29). Filter 2 applies to all leads enabled for pace detection.

**Pace Width Filter**

When enabled, this filter searches for an edge of opposite polarity to the leading edge with a magnitude of at least half the original trigger. The second edge must be between 100  $\mu\text{s}$  to 2 ms from the original edge. When a valid pace width is detected, the width is stored. When disabled only the minimum pulse width of 100  $\mu\text{s}$  is disabled. This filter is controlled by the PACECTL register, Bit 11 (see Table 29).

**BIVENTRICULAR PACERS**

As described previously, the pace algorithm expects the pace pulse to be less than 2 ms wide. In a pacer where both ventricles are paced, they can be paced simultaneously. Where they fall within the width and height limits programmed into the algorithm, a valid pace will be flagged, but only one pace pulse may be visible.

With the pace width filter enabled, the pace algorithm seeks pace pulse widths within a 100  $\mu\text{s}$  to 2 ms window. Assuming that this filter is enabled and in a scenario where two ventricle pacer pulses fire at slightly different times, resulting in the pulse showing in the lead as one large, wider pulse, a valid pace is flagged so long as the total width does not exceed 2 ms.

**PACE DETECTION MEASUREMENTS**

Design verification of the ADAS1000 digital pace algorithm includes detection of a range of simulated pace signals in addition to using the ADAS1000 and evaluation board with one pacemaker device connected to various simulated loads (approximately 200  $\Omega$  to over 2 k $\Omega$ ) and covering the following 4 waveform corners.

- Minimum pulse width (100  $\mu\text{s}$ ), minimum height (to <300  $\mu\text{V}$ )
- Minimum pulse width (100  $\mu\text{s}$ ), maximum height (up to 1.0 V)
- Maximum pulse width (2 ms), minimum height (to <300  $\mu\text{V}$ )
- Maximum pulse width (2 ms), maximum height (up to 1.0 V)

These scenarios passed with acceptable results. The use of the ac lead-off function had no obvious impact on the recorded pace height, width, or the ability of the pace detection algorithm to identify a pace pulse. The pace algorithm was also evaluated with the respiration carrier enabled; again, no differences in the threshold or pacer detect were noted from the carrier.

While these experiments validate the pace algorithm over a confined set of circumstances and conditions, they do not replace end system verification of the pacer algorithm. This can be performed in only the end system, using the system manufacturer’s specified cables and validation data set.

**EVALUATING PACE DETECTION PERFORMANCE**

ECG simulators offer a convenient means of studying the performance and ability of the ADAS1000 to capture pace signals over the range of widths and heights defined by the various regulatory standards. While the pace detection algorithm of the ADAS1000 is designed to conform to medical instrument standards, some simulators put out signals wider (or narrower) than called for in the standards, and these will be rejected as invalid by the algorithm of the ADAS1000.

The pace width acceptance window of the ADAS1000 is the tightest at the 2 ms limit. If this proves problematic, margin can be obtained by reducing the master clock frequency. As an example, using an 8.000 MHz crystal in place of the recommended 8.192 MHz crystal increases the high limit of the pace acceptance window from 2.000 ms to 2.048 ms. The low limit also increases; however, this does not impair the ability of the algorithm to detect 100 µs pace pulses.

Changing the clock frequency affects all of the other ADAS1000 frequency-related functions. Continuing with the 8.000 MHz example, the -3 dB frequencies for ECG scales by a factor of 8000/8192, with 40 Hz becoming 39.06 Hz and 150 Hz becoming 146.5 Hz, which are both still well within regulatory requirements. The respiration and ac leads-off frequencies, as well as the output data rates, also scale by the same 8000/8192 fraction.

**PACE LATENCY**

The pace algorithm always examines 128 kHz, 16-bit ECG data, regardless of the selected frame rate and ECG filter setting. A pace pulse is qualified when a valid trailing edge is detected and is flagged in the next available frame header. Pace and ECG data is always correctly time-aligned at the 128 kHz frame rate, but the additional filtering inherent in the slower frame rates delays the frame’s ECG data relative to the pace pulse flag. These

delays are summarized in Table 14 and must be taken into account to enable correct positioning of the pace event relative to the ECG data.

There is an inherent one-frame-period uncertainty in the exact location of the pace trailing edge.

**PACE DETECTION VIA SECONDARY SERIAL INTERFACE (ADAS1000 AND ADAS1000-1 ONLY)**

The ADAS1000/ADAS1000-1 provide a second serial interface for users who wish to implement their own pace detection schemes. This interface is configured as a master interface. It provides ECG data at the 128 kHz data rate only. The purpose of this interface is to allow the user to access the ECG data at a rate sufficient to allow them to run their own pace algorithm, while maintaining all the filtering and decimation of the ECG data that the ADAS1000/ADAS1000-1 offer on the standard serial interface (2 kHz and 16 kHz data rates). This dedicated pace interface uses three of the four GPIO pins, leaving one GPIO pin available even when the secondary serial interface is enabled. Note that the on-chip digital calibration to ensure channel gain matching does not apply to data that is available on this interface. This interface is discussed in more detail in the Secondary Serial Interface section.

**FILTERING**

Figure 72 shows the ECG digital signal processing. The ADC sample rate is programmable. In high performance mode, it is 2.048 MHz; in low power mode, the sampling rate is reduced to 1.024 MHz. The user can tap off framing data at one of three data rates, 128 kHz, 16 kHz, or 2 kHz. Note that although the data-word width is 24 bits for the 2 kHz and 16 kHz data rate, the usable bits are 19 and 18, respectively.

The amount of decimation depends on the selected data rate, with more decimation for the lower data rates.

Four selectable low-pass filter corners are available at the 2 kHz data rate.

Filters are cleared by a reset. Table 14 shows the filter latencies at the different data rates.

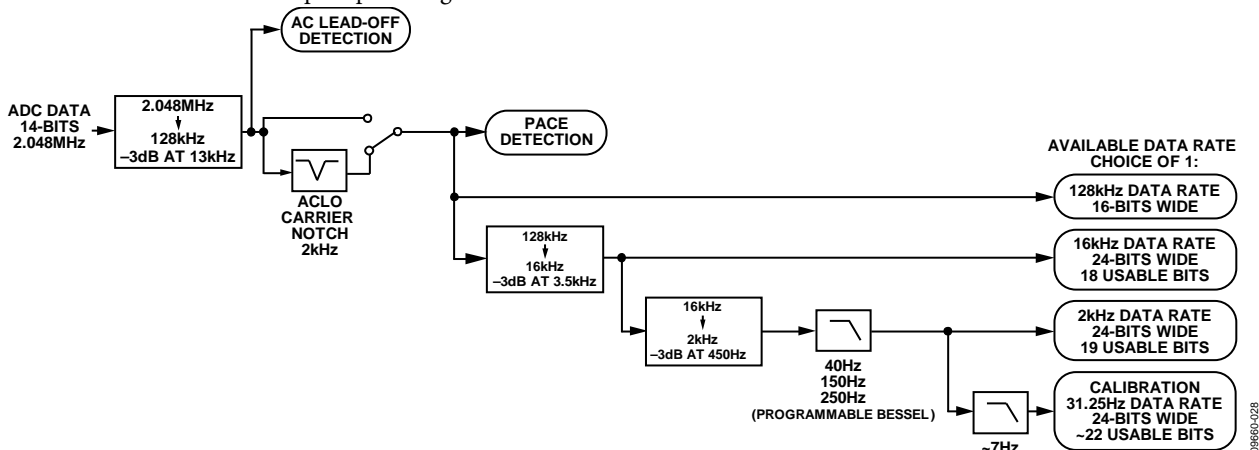

Figure 72. ECG Channel Filter Signal Flow

**Table 14. Relationship of ECG Waveform to Pace Indication<sup>1, 2, 3</sup>**

<b>Data Rate</b>	<b>Conditions</b>	<b>Apparent Delay of ECG Data Relative to Pace Event<sup>4</sup></b>
2 kHz	450 Hz ECG bandwidth	0.984 ms
	250 Hz ECG bandwidth	1.915 ms
	150 Hz ECG bandwidth	2.695 ms
	40 Hz ECG bandwidth	7.641 ms
16 kHz		109 μs
128 kHz		0

<sup>1</sup> ECG waveform delay is the time required to reach 50% of final value following a step input.

<sup>2</sup> Guaranteed by design, not subject to production test.

<sup>3</sup> There is an unavoidable residual uncertainty of 8 μs in determining the pace pulse trailing edge.

<sup>4</sup> Add 38 μs to obtain the absolute delay for any setting.

## VOLTAGE REFERENCE

The ADAS1000/ADAS1000-1/ADAS1000-2 have a high performance, low noise, on-chip 1.8 V reference for use in the ADC and DAC circuits. The REFOUT of one device is intended to drive the REFIN of the same device. The internal reference is not intended to drive significant external current; for optimum performance in gang operation with multiple devices, each device should use its own internal reference.

An external 1.8 V reference can be used to provide the required VREF. In such cases, there is an internal buffer provided for use with external reference. The REFIN pin is a dynamic load with an average input current of approximately 100  $\mu$ A per enabled channel, including respiration. When the internal reference is used, the REFOUT pin requires decoupling with a 10  $\mu$ F capacitor with low ESR (0.2  $\Omega$  maximum) in parallel with 0.01  $\mu$ F capacitor to REFGND, these capacitors should be placed as close to the device pins as possible and on the same side of the PCB as the device.

## GANG MODE OPERATION

While a single ADAS1000 or ADAS1000-1 provides the ECG channels to support a five-electrode and one-RLD electrode (or up to 8-lead) system, the device has also been designed so that it can easily extend to larger systems by paralleling up multiple devices. In this mode of operation, an ADAS1000 or ADAS1000-1 master device can easily be operated with one or more ADAS1000-2 slave devices. In such a configuration, one of the devices (ADAS1000 or ADAS1000-1) is designated as master, and any others are designated as slaves. It is important that the multiple devices operate well together; with this in mind, the pertinent inputs/outputs to interface between master and slave devices have been made available.

Note that when using multiple devices, the user must collect the ECG data directly from each device. If using a traditional 12-lead arrangement where the  $V_x$  leads are measured relative to WCT, the user should configure the ADAS1000 or ADAS1000-1 master device in lead mode with the slave ADAS1000-2 device configured for electrode mode. The LSB size for electrode and lead data differs (see Table 41 for details).

In gang mode, all devices must be operated in the same power mode (either high performance or low power) and the same data rate.

### Master/Slave

The ADAS1000 or ADAS1000-1 can be configured as a master or slave, while the ADAS1000-2 can only be configured as a slave. A device is selected as a master or slave using Bit 5, master, in the ECGCTL register (see Table 26). Gang mode is enabled by setting Bit 4, gang, in the same register. When a device is configured as a master, the SYNC\_GANG pin is automatically set as an output.

When a device is configured as a slave (ADAS1000-2), the SYNC\_GANG and CLK\_IO pins are set as inputs.

### Synchronizing Devices

The ganged devices need to share a common clock to ensure that conversions are synchronized. One approach is to drive the slave CLK\_IO pins from the master CLK\_IO pin. Alternatively, an external 8.192 MHz clock can be used to drive the CLK\_IO pins of all devices. The CLK\_IO powers up high impedance until configured in gang mode.

In addition, the SYNC\_GANG pin is used to synchronize the start of the ADC conversion across multiple devices. The SYNC\_GANG pin is automatically driven by the master and is an input to all the slaves. SYNC\_GANG is in high impedance until enabled via gang mode.

When connecting devices in gang mode, the SYNC\_GANG output is triggered once when the master device starts to convert. Therefore, to ensure that the slave device(s) receive this synchronization signal, configure the slave device first for operation and enable conversions, followed by issuing the conversion signal to the ECGCTL register in the master device.

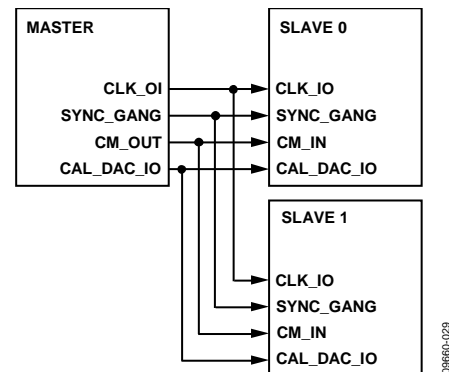

Figure 73. Master/Slave Connections in Gang Mode, Using Multiple ADAS1000/ADAS1000-1/ADAS1000-2 Devices

### Calibration

The calibration DAC signal from one device (master) can be output on the CAL\_DAC\_IO pin and used as the calibration input for other devices (slaves) when used in the gang mode of operation. This ensures that they are all being calibrated using the same signal which results in better matching across channels. This does not happen automatically in gang mode but, rather, must be configured via Table 34.

**Common Mode**

The ADAS1000/ADAS1000-1 have a dedicated CM\_OUT pin serving as an output and a CM\_IN pin as an input. In gang mode, the master device determines the common-mode voltage based on the selected input electrodes. This common-mode signal (on CM\_OUT) can then be used by subsequent slave devices (applied to CM\_IN) as the common-mode reference. All electrodes within the slave device are then measured with respect to the CM\_IN signal from the master device. See the CMREFCTL register in Table 30 for more details on the control via the serial interface. Figure 74 shows the connections between a master and slave device using multiple ADAS1000/ADAS1000-2 devices.

**Right Leg Drive**

The right leg drive comes from the master device. If the internal RLD resistors of the slave device are to contribute to the RLD loop, tie the RLD\_SJ pins of master and slave together.

**Sequencing Devices into Gang Mode**

When entering gang mode with multiple devices, both devices can be configured for operation, but the conversion enable bit (ECGCTL register, Bit 2, Table 26) of the master device should be set after the conversion enable bit of the slave device. When the master device conversion signal is set, the master device generates one edge on its SYNC\_GANG pin. This applies to any slave SYNC\_GANG inputs, allowing the devices to synchronize ADC conversions.

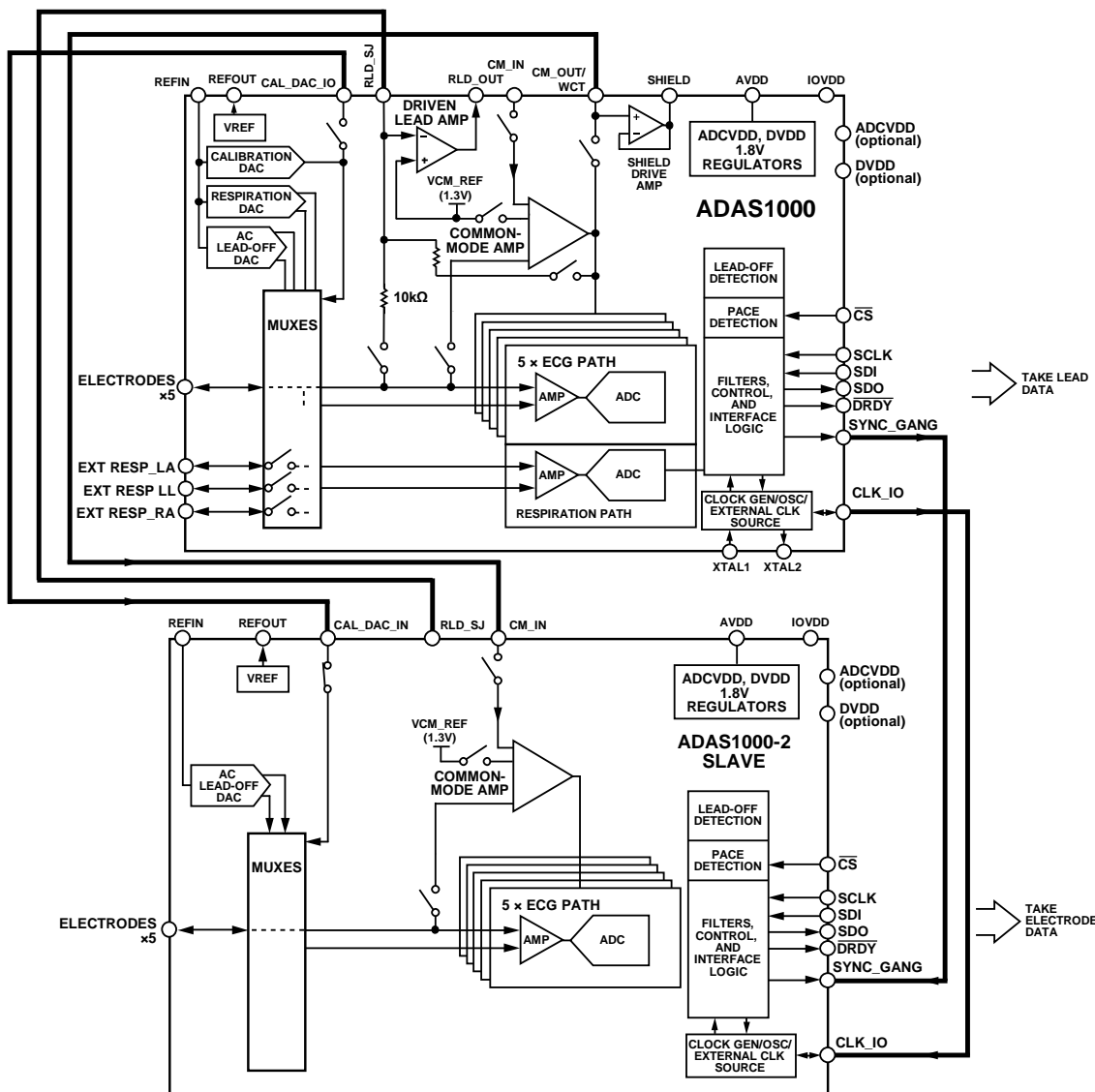

Figure 74. Configuring Multiple Devices to Extend Number of Electrodes/Leads  
(This Example Uses ADAS1000 as Master and ADAS1000-2 as Slave. Similarly the ADAS1000-1 Could be Use as Master.)

0918610-030

Table 15. Some Possible Arrangements for Gang Operation

Master	Slave 1	Slave 2	Features	Number of Electrodes	Number of Leads
ADAS1000	ADAS1000-2		ECG, respiration, pace	10 ECG, CM_IN, RLD	12-lead + spare ADC channel
ADAS1000	ADAS1000-2	ADAS1000-2	ECG, respiration, pace	15 ECG, CM_IN, RLD	15-lead + 3 spare ADC channels
ADAS1000	ADAS1000-3		ECG, respiration, pace	8 ECG, CM_IN, RLD	12-lead (derived leads)
ADAS1000-1	ADAS1000-2		ECG	10 ECG, CM_IN, RLD	12-lead + spare ADC channel
ADAS1000-3	ADAS1000-2		ECG	8 ECG, CM_IN, RLD	12-lead (derived leads)
ADAS1000-4	ADAS1000-2		ECG, respiration, pace	8 ECG, CM_IN, RLD	12-lead (derived leads)

**INTERFACING IN GANG MODE**

As shown in Figure 74, when using multiple devices, the user must collect the ECG data directly from each device.

The example shown in Figure 75 illustrates one possibility of how to approach interfacing to a master and slave device.

Note that SCLK, SDO, and SDI are shared here with individual CS lines. This requires the user to read the data on both devices twice as fast to ensure that they can capture all the data to maintain the chosen data rate and ensure they

have the relevant synchronized data. Alternative methods might use individual controllers for each device or separate SDO paths.

For some applications, digital isolation is required between the host and the ADAS1000. The example shown illustrates a means to ensure that the number of lines requiring isolation is minimized.

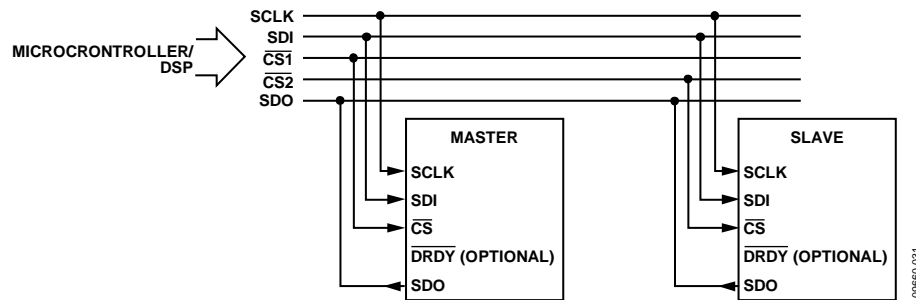

Figure 75. One Method of Interfacing to Multiple Devices



## SERIAL INTERFACES

The ADAS1000/ADAS1000-1/ADAS1000-2 are controlled via a standard serial interface allowing configuration of registers and readback of ECG data. This is an SPI-compatible interface that can operate at SCLK frequencies up to 40 MHz.

The ADAS1000/ADAS1000-1 also provide an optional secondary serial interface that is capable of providing ECG data at the 128 kHz data rate for users wishing to apply their own digital pace detection algorithm. This is a master interface that operates with an SCLK of 20.48 MHz.

### STANDARD SERIAL INTERFACE

The standard serial interface is LVTTTL-compatible when operating from a 2.3 V to 3.6 V IOVDD supply. This is the primary interface for controlling the ADAS1000/ADAS1000-1/ADAS1000-2, reading and writing registers, and reading frame data containing all the ECG data-words and other status functions within the device.

The SPI is controlled by the following five pins:

- $\overline{CS}$  (frame synchronization input). Asserting  $\overline{CS}$  low selects the device. When  $\overline{CS}$  is high, data on the SDI pin is ignored. If  $\overline{CS}$  is inactive, the SDO output driver is disabled, so that multiple SPI devices can share a common SDO pin. The  $\overline{CS}$  pin can be tied low to reduce the number of isolated paths required. When  $\overline{CS}$  is tied low, there is no frame around the data-words; therefore, the user must be aware of where they are within the frame. All data-words with 2 kHz and 16 kHz data rates contain register addresses at the start of each word within the frame. Users can resynchronize the interface by holding SDI high for 64 SCLK cycles, followed by a read of any register so that SDI is brought low for the first bit of the following word.
- SDI (serial data input pin): Data on SDI is clocked into the device on the rising edges of SCLK.
- SCLK (clocks data in and out of the device). SCLK should idle high when  $\overline{CS}$  is high.
- SDO (serial data output pin for data readback). Data is shifted out on SDO on the falling edges of SCLK. The SDO output driver is high-Z when  $\overline{CS}$  is high.
- $\overline{DRDY}$  (data ready, optional). Data ready when low, busy when high. Indicates the internal status of the ADAS1000/ADAS1000-1/ADAS1000-2 digital logic. It is driven high/busy during reset. If data frames are enabled and the frame buffer is empty, this pin is driven busy/high. If the frame buffer is full, this pin is driven low/ready. If data frames are not enabled, this pin is driven low to indicate that the device is ready to accept register read/write commands. When reading packet data, the entire packet must be read to allow the  $\overline{DRDY}$  return back high.

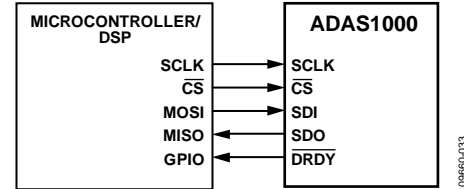

Figure 76. Serial Interface

### Write Mode

The serial word for a write is 32 bits long, MSB first. The serial interface works with both a continuous and a burst (gated) serial clock. The falling edge of  $\overline{CS}$  starts the write cycle. Serial data applied to SDI is clocked into the ADAS1000/ADAS1000-1/ADAS1000-2 on rising SCLK edges. At least 32 rising clock edges must be applied to SCLK to clock in 32 bits of data before  $\overline{CS}$  is taken high again. The addressed input register is updated on the rising edge of  $\overline{CS}$ . For another serial transfer to take place,  $\overline{CS}$  must be taken low again. Register writes are used to configure the device. Once the device is configured and enabled for conversions, frame data can be initiated to start clocking out ECG data on SDO at the programmed data rate. Normal operation for the device is to send out frames of ECG data. Typically, register reads and writes should be needed only during start-up configuration. However, it is possible to write new configuration data to the device while in framing mode. A new write command is accepted within the frame and, depending on the nature of the command, there may be a need to flush out the internal filters (wait periods) before seeing usable framing data again.

### Write/Read Data Format

Address, data, and the read/write bits are all in the same word. Data is updated on the rising edge of  $\overline{CS}$  or the first cycle of the following word. For all write commands to the ADAS1000/ADAS1000-1/ADAS1000-2, the data-word is 32 bits, as shown in Table 16. Similarly, when using data rates of 2 kHz and 16 kHz, each word is 32 bits (address bits and data bits).

Table 16. Serial Bit Assignment (Applies to All Register Writes, 2 kHz and 16 kHz Reads)

B31	[B30:B24]	[B23:B0]
R/W	Address bits[6:0]	Data bits [23:0] (MSB first)

For register reads, data is shifted out during the next word, as shown in Table 17.

Table 17. Read/Write Data Stream

Digital Pin	Command 1	Command 2	Command 2
SDI	Read Address 1	Read Address 2	Write Address 3
SDO		Address 1 Read Data 1	Address 2 Read Data 2



In the 128 kHz data rate, all write words are still 32-bit writes but the read words in the data packet are now 16 bits (upper 16 bits of register). There are no address bits, only data bits. Register space that is larger than 16 bits spans across  $2 \times 16$ -bit words (for example, pace and respiration).

### Data Frames/Packets

The general data packet structure is shown in Table 18. Data can be received in two different frame formats. For the 2 kHz and 16 kHz data rates, a 32-bit data format is used (where the register address is encapsulated in the upper byte, identifying the word within the frame) (see Table 20). For the 128 kHz data rate, words are provided in 16-bit data format (see Table 21).

When the configuration is complete, the user can begin reading frames by issuing a read command to the frame header register (see Table 52). The ADAS1000/ADAS1000-1/ADAS1000-2 continue to make frames available until another register address is written (read or write command). To continue reading frame data, continue to write all zeros on SDI, which is a write of the NOP register (Address 0x00). A frame is interrupted only when another read or write command is issued.

Each frame can be a large amount of data plus status words.  $\overline{CS}$  can toggle between each word of data within a frame, or it can be held constantly low during the entire frame.

By default, a frame contains  $11 \times 32$  bit words when reading at 2 kHz or 16 kHz data rates; similarly, a frame contains  $13 \times 16$ -bit words when reading at 128 kHz. The default frame configuration does not include the optional respiration phase word; however, this word can be included as needed.

Additionally any words not required can be excluded from the frame. To arrange the frame with the words of interest, configure the appropriate bits in the frame control register (see Table 35). The complete set of words per frame are  $12 \times 32$ -bit words for the 2 kHz or 16 kHz data rates, or  $15 \times 16$ -bit words at 128 kHz.

Any data not available within the frame can be read between frames. Reading a register interrupts the frame and requires the user to issue a new read command of Address 0x40 (see Table 52) to start framing again.

**Table 20. Default 2 kHz and 16 kHz Data Rate: 32-Bit Frame Word Format**

Register	Header	Lead I/LA	Lead II/LL	Lead III/RA	V1'/V1	V2'/V2	PACE	RESPM	RESPPH	LOFF	GPIO	CRC
Address	0x40	0x11	0x12	0x13	0x14	0x15	0x1A	0x1B	0x1C	0x1D	0x06	0x41

**Table 21. Default 128 kHz Data Rate: 16-Bit Frame Word Format<sup>1</sup>**

Register	Header	Lead I/LA	Lead II/LL	Lead III/RA	V1'/V1	V2'/V2	PACE1	PACE2	RESPM1	RESPM2	LOFF	GPIO	CRC
Address	0x40	0x11	0x12	0x13	0x14	0x15	0x1A		0x1B		0x1D	0x06	0x41

<sup>1</sup> Respiration phase words (2x 16-bit words) are not shown in this frame, but could be included.

### Read Mode

Although the primary reading function within the ADAS1000/ADAS1000-1/ADAS1000-2 is the output of the ECG frame data, the devices also allow reading of all configuration registers. To read a register, the user must first address the device with a read command containing the particular register address. If the device is already in data framing mode, the read register command can be interleaved between the frames by issuing a read register command during the last word of frame data. Data shifted out during the next word is the register read data. To return to framing mode, the user must re-enable framing by issuing a read of the frame header register (Address 0x40) (see Table 52). This register write can be used to flush out the register contents from the previous read command.

**Table 18. Example of Reading Registers and Frames**

SDI	....	NOP	Read Address N	Read frames	NOP	NOP	....
SDO	....	Frame data	Frame CRC	Register Data N	Frame header	Frame data	....

Regular register reads are always 32 bits long and MSB first.

### Serial Clock Rate

The SCLK can be up to 40 MHz, depending on the IOVDD voltage level as shown in Table 5. The minimum SCLK frequency is set by the requirement that all frame data be clocked out before the next frame becomes available.

$$SCLK(\text{min}) = \text{frame\_rate} \times \text{words\_per\_frame} \times \text{bits\_per\_word}$$

The minimum SCLK for the various frame rates is shown in Table 19.

**Table 19. SCLK Clock Frequency vs. Packet Data/Frame Rates**

Frame Rate	Word Size	Maximum Words/Frame <sup>1</sup>	Minimum SCLK
128 kHz	16 bits	15 words	30.72 MHz
16 kHz	32 bits	12 words	6.14 MHz
2 kHz	32 bits	12 words	768 kHz

<sup>1</sup> This is the full set of words that a frame contains. It is programmable and can be configured to provide only the words of interest. See Table 35.

Internal operations are synchronized to the internal master clock at either 2.048 MHz or 1.024 MHz (ECGCTL[3]: HP = 1 and HP = 0, respectively, see Table 26). Because there is no guaranteed relationship between the internal clock and the SPI's SCLK signal, an internal handshaking scheme is used to ensure safe data transfer between the two clock domains. A full handshake requires three internal clock cycles and imposes an upper speed limit on the SCLK frequency when reading frames with small word counts. This is true for all data frame rates.

$SCLK_{max} = (1.024 \text{ MHz} \times (1 + HP) \times \text{words\_per\_frame} \times \text{bits\_per\_word})/3$ ; or 40 MHz, whichever is lower.

Exceeding the maximum SCLK frequency for a particular operating mode causes erratic behavior in the  $\overline{DRDY}$  signal and results in the loss of data.

### Data Rate and Skip Mode

Although the standard frame rates available are 2 kHz, 16 kHz, and 128 kHz, there is also a provision to skip frames to further reduce the data rate. This can be configured in the frame control register (see Table 35).

### Data Ready ( $\overline{DRDY}$ )

The  $\overline{DRDY}$  pin is used to indicate that a frame composed of decimated data at the selected data rate is available to read. It is high when busy and low when ready. Send commands only when the status of  $\overline{DRDY}$  is low or ready. During power-on, the status of  $\overline{DRDY}$  is high (busy) while the device initializes itself. When initialization is complete,  $\overline{DRDY}$  goes low and the user can start configuring the device for operation. When the device is configured and enabled for conversions by writing to the conversion bit (CNVEN) in the ECGCTL register, the ADCs start to convert and the digital interface starts to make data available, loading them into the buffer when ready. If conversions are enabled and the buffer is empty, the device is not ready and  $\overline{DRDY}$  goes high. Once the buffer is full,  $\overline{DRDY}$  goes low to indicate that data is ready to be read out of the device. If the device is not enabled for conversions, the  $\overline{DRDY}$  ignores the state of the buffer full status.

When reading packets of data, the entire data packet must be read; otherwise,  $\overline{DRDY}$  stays low.

There are three methods of detecting  $\overline{DRDY}$  status.

- $\overline{DRDY}$  pin. This is an output pin from the ADAS1000/ADAS1000-1/ADAS1000-2 that indicates the device read or busy status. No data is valid while this pin is high. The  $\overline{DRDY}$  signals that data is ready to be read by driving low and remaining low until the entire frame has been read. It is cleared when the last bit of the last word in the frame is clocked onto SDO. The use of this pin is optional.
- SDO pin. The user can monitor the voltage level of the SDO pin by bringing  $\overline{CS}$  low. If SDO is low, data is ready; if high, busy. This does not require clocking the SCLK input. (CPHA = CPOL = 1 only).
- One of the first bits of valid data in the header word available on SDO is a data ready status bit (see Table 41). Within the configuration of the ADAS1000/ADAS1000-1/ADAS1000-2, the user can set the header to repeat until the data is ready. See Bit 6 (RDYRPT) in the frame control register in Table 35.

### Detecting Missed Conversion Data

To ensure that the current data is valid, the entire frame must be read at the selected data rate. If a read of the entire frame takes longer than the selected data rate allows, the internal buffer is not loaded with the latest conversion data. The frame header register (see Table 52) provides four settings to indicate an overflow of frame data. The settings of Bits[29:28] report how many frames have been missed since the last valid frame read. A missed frame may occur as a result of the last read taking too long. The data in the current frame is valid data, but it is not the current data. It is the calculation made directly after the last valid read.

To clear such an overflow, the user must read the entire frame.

**CRC Word**

Framed data integrity is provided by CRCs. For the 128 kHz frame rates, the 16-bit CRC-CCITT polynomial is used. For the 2 kHz and 16 kHz frame rates, the 24-bit CRC polynomial used.

In both cases, the CRC residue is preset to all 1s and inverted before being transmitted. The CRC parameters are summarized in Table 22. To verify that data was correctly received, software should compute a CRC on both the data and the received checksum. If data and checksum are received correctly, the resulting CRC residue should equal the check constant shown in Table 22. Note that data is shifted through the generator polynomial MSB first, the same order that it is shifted out serially. The bit and byte order of the CRC that is appended to the frame is such that the MSB of the CRC is shifted through the generator polynomial first in the same order as the data so that the CRC residue XOR'd with the inverted CRC at the end of the frame is all 1s (which is why the check constant is identical for all messages). The CRC is based only on the data that is sent out.

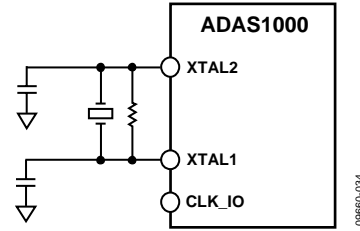

Figure 77. Input Clock

**Clocks**

The ADAS1000/ADAS1000-1/ADAS1000-2 run from an external crystal or clock input frequency of 8.192 MHz. The external clock input is provided for use in gang mode so conversions between the two devices are synchronized. In this mode, the CLK\_IO pin is an output from the master and an input from the slave. To reduce power, the CLK\_IO is disabled when not in gang mode. All features within the ADAS1000 are a function of the frequency of the externally applied clock. Using a frequency other than the 8.192 MHz previously noted causes scaling of the data rates, filter corners, ac lead off frequency, respiration frequency, and pace algorithm corners accordingly.

Table 22. CRC Polynomials

Frame Rate	CRC Size	Polynomial	Polynomial in Hex	Check Constant
2 kHz, 16 kHz	24 bits	$x^{24} + x^{22} + x^{20} + x^{19} + x^{18} + x^{16} + x^{14} + x^{13} + x^{11} + x^{10} + x^8 + x^7 + x^6 + x^3 + x^1 + x^0$	0x15D6DCB	0x15A0BA
128 kHz	16 bits	$x^{16} + x^{12} + x^5 + x^0$	0x11021	0x1D0F

## SECONDARY SERIAL INTERFACE

This second serial interface is an optional interface that can be used for the user's own pace detection purposes. This interface contains ECG data at 128 kHz data rate only. If using this interface, the ECG data is still available on the standard interface discussed previously at lower rates with all the decimation and filtering applied. If this interface is inactive, it draws no power.

Data is available in 16-bit words, MSB first.

This interface is a master interface, with the ADAS1000/ADAS1000-1 providing the SCLK, CS, SDO. Is it shared across some of the existing GPIO pins as follows:

- GPIO1/MSCLK
- GPIO0/MCS
- GPIO2/MSDO

This interface can be enabled via the GPIO register (see Table 31).

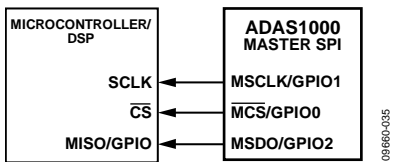

Figure 78. Master SPI Interface for External Pace Detection Purposes

The data format of the frame starts with a header word and five ECG data-words, and completes with the same CRC word as documented in Table 22 for the 128 kHz rate. All words are 16 bits. MSCLK runs at approximately 20 MHz and MCS is asserted for the entire frame with the data available on MSDO

on the falling edge of MSCLK. MSCLK idles high when MCS is deasserted.

Table 23. Master SPI Frame Format; All Words are 16 Bits

Header	Lead I/LA	Lead II/LL	Lead III/RA	V1'/V1	V2'/V2	CRC
--------	-----------	------------	-------------	--------	--------	-----

The header word consists of four bits of all 1s followed by a 12-bit sequence counter. This sequence counter increments after every frame is sent, thereby allowing the user to tell if any frames have been missed and how many.

## RESET

There are two methods of resetting the ADAS1000/ADAS1000-1/ADAS1000-2 to power-on default. Bringing the RESET line low or setting the SWRST bit in the ECGCTL register (Table 26) resets the contents of all internal registers to their power-on reset state. The falling edge of the RESET pin initiates the reset process; DRDY goes high for the duration, returning low when the RESET process is complete. This sequence takes 1.5 ms maximum. Do not write to the serial interface while DRDY is high handling a RESET command. When DRDY returns low, normal operation resumes and the status of the RESET pin is ignored until it goes low again. Software reset using the SWRST bit (see Table 26) requires that a NOP (no operation) command be issued to complete the reset cycle.

## PD FUNCTION

The PD pin powers down all functions in low power mode. The digital registers maintain their contents. The power-down function is also available via the serial interface (ECG control register, see Table 26).

### SPI OUTPUT FRAME STRUCTURE (ECG AND STATUS DATA)

Three data rates are offered for reading ECG data: low speed 2 kHz/16 kHz rates for electrode/lead data (32-bit words) and a high speed 128 kHz for electrode/lead data (16-bit words).

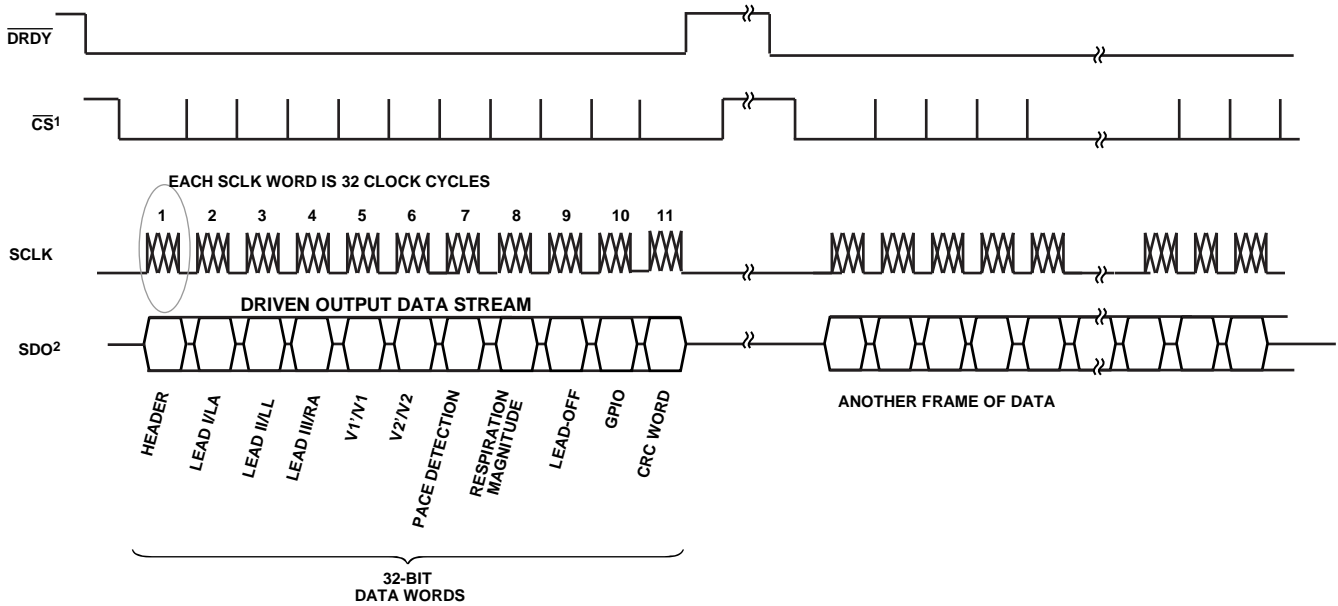

<sup>1</sup> CS MAY BE USED IN ONE OF THE FOLLOWING WAYS:

- A) HELD LOW ALL THE TIME.
- B) USED TO FRAME THE ENTIRE PACKET OF DATA.
- C) USED TO FRAME EACH INDIVIDUAL 32-BIT WORD.

<sup>2</sup> SUPER SET OF FRAME DATA, WORDS MAY BE EXCLUDED.

Figure 79. Output Frame Structure for 2 kHz and 16 kHz Data Rates with SDO Data Configured for Electrode or Lead Data

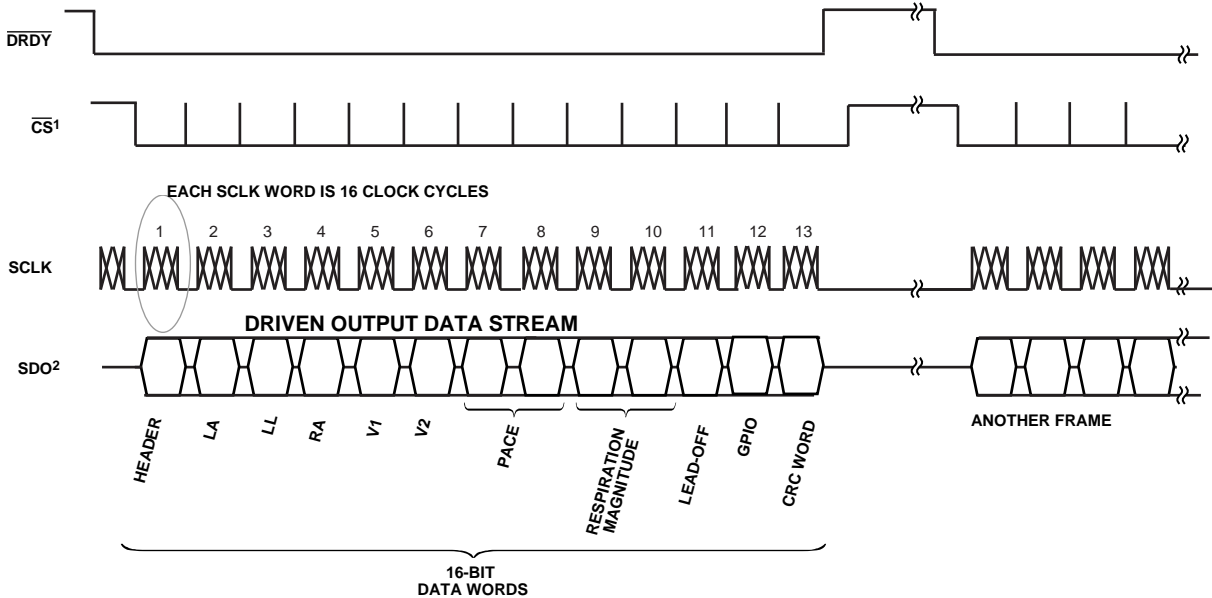

<sup>1</sup> CS MAY BE USED IN ONE OF THE FOLLOWING WAYS:

- A) HELD LOW ALL THE TIME.
- B) USED TO FRAME THE ENTIRE PACKET OF DATA.
- C) USED TO FRAME EACH INDIVIDUAL 16-BIT WORD.

<sup>2</sup> SUPER SET OF FRAME DATA, WORDS MAY BE EXCLUDED.

Figure 80. Output Frame Structure for 128 kHz Data Rate with SDO Data Configured for Electrode Data

(The 128 kHz Data Rate Can Provide Single-Ended Electrode Data or Analog Lead Mode Data Only. Digital Lead Mode Is Not Available at 128 kHz Data Rate.)

## SPI REGISTER DEFINITIONS AND MEMORY MAP

In 2 kHz and 16 kHz data rates, data takes the form of 32-bit words. Bit A6 to Bit A0 serve as word identifiers. Each 32-bit word has 24 bits of data. A third high speed data rate is also offered: 128 kHz with data in the form of 16-bit words (all 16 bits as data).

Table 24. SPI Register Memory Map

R/W <sup>1</sup>	A[6:0]	D[23:0]	Register Name	Table	Register Description	Reset Value
R	0x00	XXXXXX	NOP		NOP (no operation)	0x000000
R/W	0x01	dddddd	ECGCTL	Table 26	ECG control	0x000000
R/W	0x02	dddddd	LOFFCTL	Table 27	Lead-off control	0x000000
R/W	0x03	dddddd	RESPCTL	Table 28	Respiration control <sup>2</sup>	0x000000
R/W	0x04	dddddd	PACECTL	Table 29	Pace detection control	0x000F88
R/W	0x05	dddddd	CMREFCTL	Table 30	Common-mode, reference, and shield drive control	0xE00000
R/W	0x06	dddddd	GPIOCTL	Table 31	GPIO control	0x000000
R/W	0x07	dddddd	PACEAMPTH	Table 32	Pace amplitude threshold <sup>2</sup>	0x242424
R/W	0x08	dddddd	TESTTONE	Table 33	Test tone	0x000000
R/W	0x09	dddddd	CALDAC	Table 34	Calibration DAC	0x002000
R/W	0x0A	dddddd	FRMCTL	Table 35	Frame control	0x079000
R/W	0x0B	dddddd	FILTCTL	Table 36	Filter control	0x000000
R/W	0x0C	dddddd	LOFFUTH	Table 37	AC lead-off upper threshold	0x00FFFF
R/W	0x0D	dddddd	LOFFLTH	Table 38	AC lead-off lower threshold	0x000000
R/W	0x0E	dddddd	PACEEDGE	Table 39	Pace edge threshold <sup>2</sup>	0x000000
R/W	0x0F	dddddd	PACELVLTH	Table 40	Pace level threshold <sup>2</sup>	0x000000
R	0x11	XXXXXX	LADATA	Table 41	LA or Lead I data	0x000000
R	0x12	XXXXXX	LLDATA	Table 41	LL or Lead II data	0x000000
R	0x13	XXXXXX	RADATA	Table 41	RA or Lead III data	0x000000
R	0x14	XXXXXX	V1DATA	Table 41	V1 or V1' data	0x000000
R	0x15	XXXXXX	V2DATA	Table 41	V2 or V2' data	0x000000
R	0x1A	XXXXXX	PACEDATA	Table 42	Read pace detection data/status <sup>2</sup>	0x000000
R	0x1B	XXXXXX	RESPMAG	Table 43	Read respiration data—magnitude <sup>2</sup>	0x000000
R	0x1C	XXXXXX	RESPPH	Table 44	Read respiration data—phase <sup>2</sup>	0x000000
R	0x1D	XXXXXX	LOFF	Table 45	Lead-off status	0x000000
R	0x1E	XXXXXX	DCLEAD-OFF	Table 46	DC lead-off	0x000000
R	0x1F	XXXXXX	OPSTAT	Table 47	Operating state	0x000000
R/W	0x20	dddddd	EXTENDSW	Table 48	Extended switch for respiration inputs	0x000000
R/W	0x21	dddddd	CALLA	Table 49	User gain calibration LA	0x000000
R/W	0x22	dddddd	CALLL	Table 49	User gain calibration LL	0x000000
R/W	0x23	dddddd	CALRA	Table 49	User gain calibration RA	0x000000
R/W	0x24	dddddd	CALV1	Table 49	User gain calibration V1	0x000000
R/W	0x25	dddddd	CALV2	Table 49	User gain calibration V2	0x000000
R	0x31	dddddd	LOAMLA	Table 50	Lead-off amplitude for LA	0x000000
R	0x32	dddddd	LOAMLL	Table 50	Lead-off amplitude for LL	0x000000
R	0x33	dddddd	LOAMRA	Table 50	Lead-off amplitude for RA	0x000000
R	0x34	dddddd	LOAMV1	Table 50	Lead-off amplitude for V1	0x000000
R	0x35	dddddd	LOAMV2	Table 50	Lead-off amplitude for V2	0x000000
R	0x3A	dddddd	PACE1DATA	Table 51	Pace1 width and amplitude <sup>2</sup>	0x000000
R	0x3B	dddddd	PACE2DATA	Table 51	Pace2 width and amplitude <sup>2</sup>	0x000000
R	0x3C	dddddd	PACE3DATA	Table 51	Pace3 width and amplitude <sup>2</sup>	0x000000
R	0x40	dddddd	FRAMES	Table 52	Frame header	0x800000
R	0x41	XXXXXX	CRC	Table 53	Frame CRC	0xFFFFFFFF
x	Other	XXXXXX	Reserved <sup>3</sup>		Reserved	XXXXXX

<sup>1</sup> R/W = register both readable and writable; R = read only.

<sup>2</sup> ADAS1000 model only, ADAS1000-1/ADAS1000-2 models do not contain these features.

<sup>3</sup> Reserved bits in any register are undefined. In some cases a physical (but unused) memory bit may be present—in other cases not. Do not issue commands to reserved registers/space. Read operations of unassigned bits are undefined.

## CONTROL REGISTERS DETAILS

For each register address, the default setting is noted in a default column in addition to being noted in the function column by “(default)”; this format applies throughout the register map.

**Table 25. Serial Bit Assignment**

<b>B31</b>	<b>[B30:B24]</b>	<b>[B23:B0]</b>
R/W	Address bits	Data bits (MSB first)

**Table 26. ECG Control Register (ECGCTL) Address 0x01, Reset Value = 0x000000**

<b>R/W</b>	<b>Default</b>	<b>Bit</b>	<b>Name</b>	<b>Function</b>
R/W	0	23	LAEN	ECG channel enable; shuts down power to the channel; the input becomes high-Z.
R/W	0	22	LLEN	0 (default) = disables ECG channel. When disabled, the entire ECG channel is shut down and dissipating minimal power.
R/W	0	21	RAEN	1 = enables ECG channel.
R/W	0	20	V1EN	
R/W	0	19	V2EN	
R	0	[18:11]	Reserved	Reserved, set to 0.
R/W	0	10	CHCONFIG	Setting this bit selects the differential analog front end (AFE) input. See Figure 57. 0 (default) = single-ended input (digital lead mode or electrode mode). 1 = differential input (analog lead mode).
R/W	00	[9:8]	GAIN [1:0]	Preamplifier and anti-aliasing filter overall gain. 00 (default) = GAIN 0 = $\times 1.4$ . 01 = GAIN 1 = $\times 2.1$ . 10 = GAIN 2 = $\times 2.8$ . 11 = GAIN 3 = $\times 4.2$ (user gain calibration is required for this gain setting).
R/W	0	7	VREFBUF	VREF buffer enable. 0 (default) = disabled. 1 = enabled (when using the internal VREF, VREFBUF must be enabled).
R/W	0	6	CLKEXT	Use external clock instead of crystal oscillator. The crystal oscillator is automatically disabled if configured as a slave in gang mode and the slave device should receive the clock from the master device. 0 (default) = XTAL is clock source. 1 = CLK_IO is clock source.
R/W	0	5	Master	In gang mode, this bit selects the master (SYNC_GANG pin is configured as an output). When in single channel mode (gang = 0), this bit is ignored. ADAS1000-2 cannot be configured as a master device. 0 (default) = slave. 1 = master.
R/W	0	4	Gang	Enable gang mode. Setting this bit causes CLK_IO and SYNC_GANG to be activated. 0 (default) = single channel mode. 1 = gang mode.
R/W	0	3	HP	Selects the noise/power performance. This bit controls the ADC sampling frequency. See the Specifications section for further details. 0 (default) = 1 MSPS, low power. 1 = 2 MSPS, high performance/low noise.
R/W	0	2	CNVEN	Conversion enable. Setting this bit enables the ADC conversion and filters. 0 (default) = idle. 1 = conversion enable.
R/W	0	1	PWREN	Power enable. Clearing this bit powers down the device. All analog blocks are powered down and the external crystal is disabled. The register contents are retained during power down as long as DVDD is not removed. 0 (default) = power down. 1 = power enable.
R/W	0	0	SWRST	Software reset. Setting this bit clears all registers to their reset value. This bit automatically clears itself. The software reset requires a NOP command to complete the reset. 0 (default) = NOP. 1 = reset.

Table 27. Lead-Off Control Register (LOFFCTL) Address 0x02, Reset Value = 0x000000

R/W	Default	Bit	Name	Function
R/W	0	23	LAPH	AC lead-off phase.
R/W	0	22	LLPH	0 (default) = in phase.
R/W	0	21	RAPH	1 = 180° out of phase.
R/W	0	20	V1PH	
R/W	0	19	V2PH	
R/W	0	18	CEPH	
R/W	0	17	LAACLOEN	Individual electrode ac lead-off enable. AC lead-off enables are the OR of ACSEL and the individual ac lead-off channel enables. 0 (default) = ac lead-off disabled. 1 = ac lead-off enabled.
R/W	0	16	LLACLOEN	
R/W	0	15	RAACLOEN	
R/W	0	14	V1ACLOEN	
R/W	0	13	V2ACLOEN	
R/W	0	12	CEACLOEN	
R	0	[11:9]	Reserved	Reserved, set to 0.
R/W	00	[8:7]	ACCURRENT	Set current level for ac lead-off. 00 (default) = 12.5 nA rms. 01 = 25 nA rms. 10 = 50 nA rms. 11 = 100 nA rms.
	00	[6:5]	Reserved	Reserved, set to 0.
R/W	000	[4:2]	DCCURRENT	Set current level for dc lead-off (active only for ACSEL = 0). 000 (default) = 0 nA. 001 = 10 nA. 010 = 20 nA. 011 = 30 nA. 100 = 40 nA. 101 = 50 nA. 110 = 60 nA. 111 = 70 nA.
R/W	0	1	ACSEL	DC or AC (out-of-band) lead-off detection. ACSEL acts as a global ac lead-off enable for RA, LL, LA, V1, V2 electrodes (CE ac lead-off is not enabled using ACSEL). AC lead-off enables are the OR of ACSEL and the individual ac lead-off channel enables. If LOFFEN = 0, this bit is don't care. If LOFFEN = 1, 0 (default) = dc lead-off detection enabled. (Individual ac lead-off can be enabled through Bits[17:12].) 1 = dc lead-off detection disabled. AC lead-off detection enabled (all electrodes except CE electrode). When the calibration DAC is enabled, ac lead-off is disabled.
R/W	0	0	LOFFEN	Enable lead-off detection. 0 (default) = lead-off disabled. 1 = lead-off enabled.



Table 28. Respiration Control Register (RESPCTL) Address 0x03, Reset Value = 0x000000<sup>1</sup>

R/W	Default	Bit	Name	Function															
		[23:17]	Reserved	Reserved, set to 0.															
R/W	0	16	RESPALTFREQ	Setting this bit to 1 makes the respiration waveform on the GPIO3 pin periodic every cycle. Use in conjunction with RESFREQ to select drive frequency. 0 (default) = periodic every N cycles (default). 1 = periodic every cycle.															
R/W	0	15	RESPEXTSYNC	Set this bit to 1 to drive the MSB of the respiration DAC out onto the GPIO3 pin. This signal can be used to synchronize an external generator to the respiration carrier. It is a constant period only when RESPALTFREQ = 1. 0 (default) = normal GPIO3 function. 1 = MSB of RESPDAC driven onto GPIO3 pin.															
R/W	0	14	RESPEXTAMP	For use with an external instrumentation amplifier with respiration circuit. Bypasses the on-chip amplifier stage and input directly to the ADC. See Figure 68. 0 (default) = disabled 1 = enabled															
R/W	0	13	RESPOUT	Selects external respiration drive output. RESPDAC_RA is automatically selected when RESPCAP = 1 0 (default) = RESPDAC_LL and RESPDAC_RA. 1 = RESPDAC_LA and RESPDAC_RA.															
R/W	0	12	RESPCAP	Selects source of respiration capacitors. 0 (default) = use internal capacitors. 1 = use external capacitors.															
R/W	0000	[11:8]	RESPGAIN [3:0]	Respiration in amp gain (saturates at 10). 0000 (default) = ×1 gain. 0001 = ×2 gain. 0010 = ×3 gain. ... 1000 = ×9 gain. 1001 = ×10 gain. 11xx = ×10 gain.															
R/W	0	7	RESPEXTSEL	Selects between EXT_RESP_LA or EXT_RESP_LL paths. Applies only if the external respiration is selected in RESPSEL. EXT_RESP_RA is automatically enabled. 0 (default) = EXT_RESP_LL. 1 = EXT_RESP_LA.															
R/W	00	[6:5]	RESPSEL [1:0]	Set leads for respiration measurement. 00 (default) = Lead I. 01 = Lead II. 10 = Lead III. 11 = external respiration path.															
R/W	00	[4:3]	RESPAMP	Set the test tone amplitude for respiration drive signal. 00 (default) = amplitude/8. 01 = amplitude/4. 10 = amplitude/2. 11 = amplitude.															
R/W	00	[2:1]	RESPFREQ	Set frequency for respiration. <table border="1"> <thead> <tr> <th>RESPFREQ</th> <th>RESPALTFREQ = 0</th> <th>RESPALTFREQ = 1 (periodic)</th> </tr> </thead> <tbody> <tr> <td>00 (default)</td> <td>56 kHz</td> <td>64 kHz</td> </tr> <tr> <td>01</td> <td>54 kHz</td> <td>56.9 kHz</td> </tr> <tr> <td>10</td> <td>52 kHz</td> <td>51.2 kHz</td> </tr> <tr> <td>11</td> <td>50 kHz</td> <td>46.5 kHz</td> </tr> </tbody> </table>	RESPFREQ	RESPALTFREQ = 0	RESPALTFREQ = 1 (periodic)	00 (default)	56 kHz	64 kHz	01	54 kHz	56.9 kHz	10	52 kHz	51.2 kHz	11	50 kHz	46.5 kHz
RESPFREQ	RESPALTFREQ = 0	RESPALTFREQ = 1 (periodic)																	
00 (default)	56 kHz	64 kHz																	
01	54 kHz	56.9 kHz																	
10	52 kHz	51.2 kHz																	
11	50 kHz	46.5 kHz																	
R/W	0	0	RESPEN	Enable respiration. 0 (default) = respiration disabled. 1 = respiration enabled.															

<sup>1</sup> ADAS1000 model only, ADAS1000-1/ADAS1000-2 models do not contain these features.

Table 29. Pace Detection Control Register (PACECTL) Address 0x04, Reset Value = 0x000F88<sup>1</sup>

R/W	Default	Bit	Name	Function
		[23:12]	Reserved	Reserved, set to 0
R/W	1	11	PACEFILTW	Pace width filter 0 = filter disabled 1 (default) = filter enabled
R/W	1	10	PACETFILT2	Pace Validation Filter 2 0 = filter disabled 1 (default) = filter enabled
R/W	1	9	PACETFILT1	Pace Validation Filter 1 0 = filter disabled 1 (default) = filter enabled
R/W	11	[8:7]	PACE3SEL [1:0]	Set lead for pace detection measurement
R/W	00	[6:5]	PACE2SEL [1:0]	00 = Lead I
R/W	01	[4:3]	PACE1SEL [1:0]	01 = Lead II 10 = Lead III 11 = Lead aVF
R/W	0	2	PACE3EN	Enable pace detection algorithm
R/W	0	1	PACE2EN	0 (default) = pace detection disabled
R/W	0	0	PACE1EN	1 = pace detection enabled

<sup>1</sup> ADAS1000 model only, ADAS1000-1/ADAS1000-2 models do not contain these features.

Table 30. Common-Mode, Reference, and Shield Drive Control Register (CMREFCTL) Address 0x05, Reset Value = 0xE00000

R/W	Default	Bit	Name	Function
R/W	1	23	LACM	Common-mode electrode select.
R/W	1	22	LLCM	Any combination of the five input electrodes can be used to create the common-mode signal, VCM. Bits[23:19] are ignored when Bit 2 is selected. Common mode is the average of the selected electrodes. When a single electrode is selected, common mode is the signal level of that electrode alone. The common-mode signal can be driven from the internal VCM_REF (1.3 V) when Bits [23:19] = 0. 0 = does not contribute to the common mode. 1 = contributes to the common mode.
R/W	1	21	RACM	
R/W	0	20	V1CM	
R/W	0	19	V2CM	
	0	[18:15]	Reserved	
R/W	0	14	LARLD	RLD summing junction. Note that if the RLD amplifier is disabled (using RLDSEL), these switches are not automatically forced open, and the user must disable them using Bits[9:14]. 0 (default) = does not contribute to RLD input. 1 = contributes to RLD input.
R/W	0	13	LLRLD	
R/W	0	12	RARLD	
R/W	0	11	V1RLD	
R/W	0	10	V2RLD	
R/W	0	9	CERLD	
R/W	0	8	CEREFEN	Common electrode (CE) reference, see Figure 57. 0 (default) = common electrode disabled. 1 = common electrode enabled.
R/W	0000	[7:4]	RLDSEL [3:0] <sup>1</sup>	Select electrode for reference drive. 0000 (default) = RLD_OUT. 0001 = LA. 0010 = LL. 0011 = RA. 0100 = V1. 0101 = V2. 0110 to 1111 = reserved.
R/W	0	3	DRVCM	Common-mode output. When set, the internally derived common-mode signal is driven out of the common-mode pin. This bit has no effect if an external common mode is selected. 0 (default) = common mode is not driven out. 1 = common mode is driven out of the external common-mode pin.
R/W	0	2	EXTCM	Select the source of common mode (use when operating multiple devices together). 0 (default) = internal common mode selected. 1 = external common mode selected (all the internal common-mode switches are off).
R/W	0	1	RLDSEL <sup>1</sup>	Enable right leg drive reference electrode. 0 (default) = disabled. 1 = enabled.
R/W	0	0	SHLDEN <sup>1</sup>	Enable shield drive. 0 (default) = shield drive disabled. 1 = shield drive enabled.

<sup>1</sup> ADAS1000 and ADAS1000-1 models only, ADAS1000-2 models does not contain these features.

**Table 31. GPIO Control Register (GPIOCTL) Address 0x06, Reset Value = 0x000000**

R/W	Default	Bit	Name	Function
	0	[23:19]	Reserved	Reserved, set to 0
R/W	0	18	SPIFW	Frame secondary SPI words with chip select 0 (default) = $\overline{\text{MCS}}$ asserted for entire frame 1 = $\overline{\text{MCS}}$ asserted for individual word
R/W	0	17	Reserved	Reserved, set to 0
R/W	0	16	SPIEN	Secondary SPI enable (ADAS1000 and ADAS1000-1 only); SPI interface providing ECG data at 128 kHz data rate for external digital pace algorithm detection, uses GPIO0, GPIO1, GPIO2 pins 0 (default) = disabled 1 = enabled; the individual control bits for GPIO0, GPIO1, GPIO2 are ignored; GPIO3 is not affected by SPIEN
R/W	00	[15:14]	G3CTL [1:0]	State of GPIO3 pin 00 (default) = high impedance 01 = input 10 = output 11 = open drain
R/W	0	13	G3OUT	Output value to be written to GPIO3 when the pin is configured as an output or open drain 0 (default) = low value 1 = high value
R	0	12	G3IN	Read only; input value read from GPIO3 when the pin is configured as an input 0 (default) = low value 1 = high value
R/W	00	[11:10]	G2CTL [1:0]	State of GPIO2 pin 00 (default) = high impedance 01 = input 10 = output 11 = open drain
R/W	0	9	G2OUT	Output value to be written to GPIO2 when the pin is configured as an output or open drain 0 (default) = low value 1 = high value
R	0	8	G2IN	Read only Input value read from GPIO2 when the pin is configured as an input 0 (default) = low value 1 = high value
R/W	00	[7:6]	G1CTL [1:0]	State of GPIO1 pin 00 (default) = high impedance 01 = input 10 = output 11 = open drain
R/W	0	5	G1OUT	Output value to be written to GPIO1 when the pin is configured as an output or open drain 0 (default) = low value 1 = high value
R	0	4	G1IN	Read only; input value read from GPIO1 when the pin is configured as an input 0 (default) = low value 1 = high value
R/W	00	[3:2]	G0CTL [1:0]	State of the GPIO0 pin 00 (default) = high impedance 01 = input 10 = output 11 = open drain
R/W	0	1	G0OUT	Output value to be written to GPIO0 when pin is configured as an output or open drain 0 (default) = low value 1 = high value
R	0	0	G0IN	(Read only) input value read from GPIO0 when pin is configured as an input 0 (default) = low value 1 = high value

Table 32. Pace Amplitude Threshold Register (PACEAMPTH) Address 0x07, Reset Value = 0x242424<sup>1</sup>

R/W	Default	Bit	Name	Function
R/W	0010 0100	[23:16]	PACE3AMPTH	Pace amplitude threshold
R/W	0010 0100	[15:8]	PACE2AMPTH	Threshold = $N \times 2 \times VREF/GAIN/2^{16}$
R/W	0010 0100	[7:0]	PACE1AMPTH	

<sup>1</sup> ADAS1000 model only, ADAS1000-1/ADAS1000-2 models do not contain these features.

Table 33. Test Tone Register (TESTTONE) Address 0x08, Reset Value = 0x000000

R/W	Default	Bit	Name	Function
R/W	0	23	TONLA	Tone select
R/W	0	22	TONLL	0 (default) = 1.3 V VCM_REF
R/W	0	21	TONRA	1 = 1 mV sine wave or square wave for TONINT = 1, no connect for TONINT=0
R/W	0	20	TONV1	
R/W	0	19	TONV2	
R/W	0	[18:5]	Reserved	Reserved, set to 0
R/W	00	[4:3]	TONTYPE	00 (default) = 10 Hz sine wave 01 = 150 Hz sine wave 1x = 1 Hz, 1 mV square wave
R/W	0	2	TONINT	Test tone internal or external 0 (default) = external test tone; test tone to be sent out through CAL_DAC_IO and applied externally to enabled channels 1 = internal test tone; disconnects external switches for all ECG channels and connects the calibration DAC test tone internally to all ECG channels; in gang mode, the CAL_DAC_IO is connected, and the slave disables the calibration DAC
R/W	0	1	TONOUT	Test tone out enable 0 (default) = disconnects test tone from CAL_DAC_IO during internal mode only 1 = connects CAL_DAC_IO to test tone during internal mode
R/W	0	0	TONEN	Enables an internal test tone to drive entire signal chain, from preamplifier to SPI interface; this tone comes from the calibration DAC and goes to the preamplifier through the internal mux; when TONEN (calibration DAC) is enabled, ac lead-off is disabled 0 (default) = disable the test tone 1 = enable the 1 mV sine wave test tone (calibration mode has priority)

Table 34. Calibration DAC Register (CALDAC) Address 0x09, Reset Value = 0x002000<sup>1</sup>

R/W	Default	Bit	Name	Function
	0	[23:14]	Reserved	Reserved, set to 0.
R/W	1	13	CALCHPEN	Calibration chop clock enable. The calibration DAC output (CAL_DAC_IO) can be chopped to lower 1/f noise. Chopping is performed at 256 kHz. 0 = disabled. 1 (default) = enabled.
R/W	0	12	CALMODEEN	Calibration mode enable. 0 (default) = disable calibration mode. 1 = enable calibration mode; connect CAL_DAC_IO, begin data acquisition on ECG channels.
R/W	0	11	CALINT	Calibration internal or external. 0 (default) = external calibration to be performed externally by looping CAL_DAC_IO around into ECG channels. 1 = internal calibration; disconnects external switches for all ECG channels and connects calibration DAC signal internally to all ECG channels.
R/W	0	10	CALDACEN	Enable 10-bit calibration DAC for calibration mode or external use. 0 (default) = disable calibration DAC. 1 = enable calibration DAC. If a master device and not in calibration mode, also connects the calibration DAC signal out to the CAL_DAC_IO pin for external use. If in slave mode, the calibration DAC is disabled to allow master to drive the slave CAL_DAC_IO pin. When the calibration DAC is enabled, ac lead-off is disabled.
R/W	000000000	[9:0]	CALDATA[9:0]	Set the calibration DAC value.

<sup>1</sup> To ensure successful update of the calibration DAC, the serial interface must issue four additional SCLK cycles after writing the new calibration DAC register word.

Table 35. Frame Control Register (FRMCTL) Address 0x0A, Reset Value = 0x079000

R/W	Default	Bit	Name	Function
R/W	0	23	LEAD I/LADIS	Include/exclude word from ECG data frame. If the electrode/lead is included in the data-word and the electrode falls off, the data-word is undefined.
R/W	0	22	LEADII/LLDIS	0 (default) = included in frame.
R/W	0	21	LEADIII/RADIS	1 = exclude from frame.
R/W	0	20	V1DIS	
R/W	0	19	V2DIS	
R/W	1111	[18:15]	Reserved	Reserved, set to 1111.
R/W	0	14	PACEDIS <sup>1</sup>	Pace detection. 0 (default) = included in frame. 1 = exclude from frame.
R/W	0	13	RESPMDIS <sup>1</sup>	Respiration magnitude. 0 (default) = included in frame. 1 = exclude from frame.
R/W	1	12	RESPPHDIS <sup>1</sup>	Respiration phase. 0 = included in frame. 1 (default) = exclude from frame.
R/W	0	11	LOFFDIS	Lead-off status. 0 (default) = included in frame. 1 = exclude from frame.
R/W	0	10	GPIODIS	GPIO word disable. 0 (default) = included in frame. 1 = exclude from frame.
R/W	0	9	CRCDIS	CRC word disable. 0 (default) = included in frame. 1 = exclude from frame.
R/W	0	8	RESERVED	Reserved, set to 0.
R/W	0	7	ADIS	Automatically excludes PACEDIS[14], RESPMDIS[13], LOFFDIS[11] words if their flags are not set in the header. 0 (default) = fixed frame format. 1 = autodisable words (words per frame changes).
R/W	0	6	RDYRPT	Ready repeat. If this bit is set and the frame header indicates data is not ready, the frame header is continuously sent until data is ready. 0 (default) = always send entire frame. 1 = repeat frame header until ready.
R/W	0	5	Reserved	Reserved, set to 0.
R/W	0	4	DATAFMT	Sets the output data format, see Figure 57. 0 (default) = digital lead/vector format (available only in 2 kHz and 16 kHz data rates). 1 = electrode format.
R/W	00	[3:2]	SKIP[1:0]	Skip interval. This field provides a way to decimate the data. 00 (default) = output every frame. 01 = output every other frame 1x = output every 4 <sup>th</sup> frame.
R/W	00	[1:0]	FRMRATE[1:0]	Sets the output data rate. 00 (default) = 2 kHz output data rate. 01 = 16 kHz output data rate. 10 = 128 kHz output data rate (DATAFMT must be set to 1). 11 = 31.25 Hz.

<sup>1</sup> ADAS1000 model only, ADAS1000-1/ADAS1000-2 models do not contain these features.

**Table 36. Filter Control Register (FILTCTL) Address 0x0B, Reset Value = 0x000000**

R/W	Default	Bit	Name	Function
R/W	0	[23:6]	Reserved	Reserved, set to 0
R/W	0	5	MN2K	2 kHz notch bypass for SPI master 0 (default) = notch filter bypassed 1 = notch filter present
R/W	0	4	N2KBP	2 kHz notch bypass 0 (default) = notch filter present 1 = notch filter bypassed
R/W	00	[3:2]	LPF[1:0]	00 (default) = 40 Hz 01 = 150 Hz 10 = 250 Hz 11 = 450 Hz
R/W	00	[1:0]	Reserved	Reserved, set to 0

**Table 37. AC Lead-Off Upper Threshold Register (LOFFUTH) Address 0x0C, Reset Value = 0x00FFFF**

R/W	Default	Bit	Name	Function
	0	[23:20]	Reserved	Reserved, set to 0
R/W	0	[19:16]	ADCOVER[3:0]	ADC overrange threshold An ADC out-of-range error is flagged if the ADC output is greater than the overrange threshold; the overrange threshold is offset from the maximum value $Threshold = max\_value - ADCOVER \times 2^6$ 0000 = maximum value (disabled) 0001 = max_value – 64 0010 = max_value – 128 ... 1111 = max_value – 960
R/W	0xFFFF	[15:0]	LOFFUTH[15:0]	Applies to ac lead-off upper threshold only; lead-off is detected if the output is $\geq N \times 2 \times VREF/GAIN/2^{16}$ 0 = 0V

**Table 38. AC Lead-Off Lower Threshold Register (LOFFLTH) Address 0x0D, Reset Value = 0x000000**

R/W	Default	Bit	Name	Function
	0	[23:20]	Reserved	Reserved, set to 0
R/W	0	[19:16]	ADCUNDR[3:0]	ADC underrange threshold An ADC out-of-range error is flagged if the ADC output is less than the underrange threshold $Threshold = min\_value + ADCUNDR \times 2^6$ 0000 = minimum value (disabled) 0001 = min_value + 64 0010 = min_value + 128 ... 1111 = min_value + 960
R/W	0	[15:0]	LOFFLTH[15:0]	Applies to ac lead-off lower threshold only; lead-off is detected if the output is $\leq N \times 2 \times VREF/GAIN/2^{16}$ 0 = 0V



Table 39. Pace Edge Threshold Register (PACEEDGETH) Address 0x0E, Reset Value = 0x000000<sup>1</sup>

R/W	Default	Bit	Name	Function
R/W	0	[23:16]	PACE3EDGTH	Pace edge trigger threshold 0 = PACEAMPTH/2 1 = VREF/GAIN/2 <sup>16</sup> N = N × VREF/GAIN/2 <sup>16</sup>
R/W	0	[15:8]	PACE2EDGTH	
R/W	0	[7:0]	PACE1EDGTH	

<sup>1</sup> ADAS1000 model only, ADAS1000-1/ADAS1000-2 models do not contain these features.

Table 40. Pace Level Threshold Register (PACELVLTH) Address 0x0F, Reset Value = 0x000000<sup>1</sup>

R/W	Default	Bit	Name	Function
R/W	0	[23:16]	PACE3LVLTH[7:0]	Pace level threshold; This is a signed value -1 = 0xFF = -VREF/GAIN/2 <sup>16</sup> 0 = 0x00 = 0 V +1 = 0x01 = +VREF/GAIN/2 <sup>16</sup> N = N × VREF/GAIN/2 <sup>16</sup>
R/W	0	[15:8]	PACE2LVLTH[7:0]	
R/W	0	[7:0]	PACE1LVLTH[7:0]	

<sup>1</sup> ADAS1000 model only, ADAS1000-1/ADAS1000-2 models do not contain these features.

Table 41. Read Electrode/Lead Data Registers (Electrode/Lead) Address 0x11 to 0x15, Reset Value = 0x000000<sup>1</sup>

R/W	Default	Bit	Name	Function
		[31:24]	Address [7:0]	0x11: LA or Lead I. 0x12: LL or Lead II. 0x13: RA or Lead III. 0x14: V1 or V1'. 0x15: V2 or V2'.
R	0	[23:0]	ECG data	Channel data value. Data left justified (MSB) irrespective of data rate. In electrode format, the value is an unsigned integer. In vector format, the value is a signed two's complement integer format. Lead/Vector format has a 2× range compared to electrode format because it can swing from +VREF to -VREF; therefore, the LSB size is doubled.  Electrode format and Analog Lead Format: Minimum value (000...) = 0 V Maximum value (1111....) = VREF/GAIN $LSB = (2 \times VREF/GAIN)/(2^N - 1)$  Digital Lead format: Minimum value (1000...) = -(VREF/GAIN) Maximum value (0111....) = +VREF/GAIN $LSB = 4 \times (VREF/GAIN)/(2^N - 1)$  where N = number of data bits: 16 for 128 kHz data rate or 24 for 2 kHz/16 kHz data rate.

<sup>1</sup> If using 128 kHz data rate in frame mode, only the upper 16 bits are sent. If using the 128 kHz data rate in regular read/write mode, all 32 bits are sent.

**Table 42. Read Pace Detection Data/Status Register (PACEDATA) Address 0x1A, Reset Value = 0x000000<sup>1, 2, 3</sup>**

R/W	Default	Bit	Name	Function
R	0	23	Pace 3 detected	Pace 3 detected. This bit is set once a pace pulse is detected. This bit is set on the trailing edge of the pace pulse. 0 = pace pulse not detected in current frame. 1 = pace pulse detected in this frame.
R	000	[22:20]	Pace Channel 3 width	This bit is $\log_2$ (width) – 1 of the pace pulse. Width = $2^{N+1}/128$ kHz.
R	0000	[19:16]	Pace Channel 3 height	This bit is the $\log_2$ (height) of the pace pulse. Height = $2^N \times VREF/GAIN/2^{16}$ .
R	0	15	Pace 2 detected	Pace 2 detected. This bit is set once a pace pulse is detected. This bit is set on the trailing edge of the pace pulse. 0 = pace pulse not detected in current frame. 1 = pace pulse detected in this frame.
R	000	[14:12]	Pace Channel 2 width	This bit is $\log_2$ (width) – 1 of the pace pulse. Width = $2^{N+1}/128$ kHz.
R	0000	[11:8]	Pace Channel 2 height	This bit is the $\log_2$ (height) of the pace pulse. Height = $2^N \times VREF/GAIN/2^{16}$ .
R	0	7	Pace 1 detected	Pace 1 detected. This bit is set once a pace pulse is detected. This bit is set on the trailing edge of the pace pulse. 0 = pace pulse not detected in current frame. 1 = pace pulse detected in this frame.
R	000	[6:4]	Pace Channel 1 width	This bit is $\log_2$ (width) – 1 of the pace pulse. Width = $2^{N+1}/128$ kHz.
R	0000	[3:0]	Pace Channel 1 height	This bit is the $\log_2$ (height) of the pace pulse. Height = $2^N \times VREF/GAIN/2^{16}$ .

<sup>1</sup> If using 128 kHz data rate in frame mode, this word is stretched over two 16-bit words. If using the 128 kHz data rate in regular read/write mode, all 32 bits are sent.  
<sup>2</sup> Log data for width and height is provided here to ensure that it fits in one full 32-bit data-word. As a result there may be some amount of error in the resulting value.  
 For more accurate reading, read the 0x3A, 0x3B, 0x3C registers (see Table 51).  
<sup>3</sup> ADAS1000 model only, ADAS1000-1/ADAS1000-2 models do not contain these features.

**Table 43. Read Respiration Data—Magnitude Register (RESPMAG) Address 0x1B, Reset Value = 0x000000<sup>1, 2</sup>**

R/W	Default	Bit	Name	Function
R	0	[23:0]	Respiration magnitude[23:0]	Magnitude of respiration signal. This is an unsigned value. $2 \times VREF \times (2^{24} - 1)/(1.6468 \times \text{respiration gain})$ .

<sup>1</sup> If using 128 kHz data rate in frame mode, this word is stretched over two 16-bit words. If using the 128 kHz data rate in regular read/write mode, all 32 bits are sent.  
<sup>2</sup> ADAS1000 model only, ADAS1000-1/ADAS1000-2 models do not contain these features.

**Table 44. Read Respiration Data—Phase Register (RESPPH) Address 0x1C, Reset Value = 0x000000<sup>1, 2</sup>**

R/W	Default	Bit	Name	Function
R	0	[23:0]	Respiration phase[23:0]	Phase of respiration signal. Can be interpreted as either signed or unsigned value. If unsigned, the range is from 0 to $2\pi$ . If signed, the range is from $-\pi$ to $+\pi$ . $0x000000 = 0$ . $0x000001 = 2\pi/2^{24}$ . $0x400000 = \pi/2$ . $0x800000 = +\pi = -\pi$ . $0xC00000 = +3\pi/2 = -\pi/2$ . $0xFFFFF = +2\pi(1 - 2^{-24}) = -2\pi/2^{24}$ .

<sup>1</sup> This register is not part of framing data, but may be read by issuing a register read command of this address.  
<sup>2</sup> ADAS1000 model only, ADAS1000-1/ADAS1000-2 models do not contain these features.

Table 45. Lead-Off Status Register (LOFF) Address 0x1D, Reset Value = 0x000000

R/W	Default	Bit	Name	Function
R	0	23	RLD lead-off Status	Electrode connection status.
		22	LA lead-off status	If either dc or ac lead-off is enabled, these bits are the corresponding lead-off status. If both dc and ac lead-off are enabled, these bits reflect only the ac lead-off status. DC lead-off is available in the DCLEAD-OFF register (see Table 46).
		21	LL lead-off status	The common electrodes have only dc lead-off detection.
		20	RA lead-off status	An ac lead-off signal can be injected into the common electrode, but there is no ADC input to measure its amplitude. If the common electrode is off, it affects the ac lead-off amplitude of the other electrodes.
		19	V1 lead-off status	
		18	V2 lead-off status	
		13	CELO	These bits accumulate in the frame buffer and are cleared when the frame buffer is loaded into the SPI buffer. 0 = electrode is connected. 1 = electrode is disconnected.
R	0	[17:14]	Reserved	Reserved.
R	0	12	LAADCOR	ADC out of range error.
		11	LLADCOR	These status bits indicate the resulting ADC code is out of range.
		10	RAADCOR	These bits accumulate in the frame buffer and are cleared when the frame buffer is loaded into the SPI buffer.
		9	V1ADCOR	
		8	V2ADCOR	
R	0	[7:0]	Reserved	Reserved.

Table 46. DC Lead-Off Register (DCLEAD-OFF) Address 0x1E, Reset Value = 0x000000<sup>1</sup>

R/W	Default	Bit	Name	Function
R	0	23	RLD input overrange	The dc lead-off detection is comparator based and compares to a fixed level. Individual electrode bits flag indicate if the dc lead-off comparator threshold level has been exceeded.
		22	LA input overrange	0 = electrode < overrange threshold, 2.4 V.
		21	LL input overrange	1 = electrode > overrange threshold, 2.4 V.
		20	RA input overrange	
		13	CE input overrange	
R	0	[19:14] [8:3]	Reserved	Reserved.
R	0	12	RLD input underrange	The dc lead-off detection is comparator based and compares to a fixed level. Individual electrode bits indicate if the dc lead-off comparator threshold level has been exceeded.
		11	LA input underrange	0 = electrode > underrange threshold, 0.2 V.
		10	LL input underrange	1 = electrode < underrange threshold, 0.2 V.
		9	RA input underrange	
		2	CE input underrange	
R	0	[1:0]	Reserved	

<sup>1</sup> This register is not part of framing data, but can be read by issuing a register read command of this address.

**Table 47. Operating State Register (OPSTAT) Address 0x1F, Reset Value = 0x000000<sup>1</sup>**

R/W	Default	Bit	Name	Function
R	0	[23:4]	Reserved	Reserved.
R	0	3	Internal error	Internal digital failure. This is set if an error is detected in the digital core.
R	0	2	Configuration status	This bit is set after a reset indicating that the configuration has not been read yet. Once the configuration is set, this bit is ready. 0 = ready. 1 = busy.
R	0	1	PLL lock	PLL lock lost. This bit is set if the internal PLL loses lock after it is enabled and locked. This bit is cleared once this register is read or the PWREN bit (Address 0x01[1]) is cleared. 0 = PLL locked. 1 = PLL lost lock.
R	0	0	PLL locked status	This bit indicates the current state of the PLL locked status. 0 = PLL not locked. 1 = PLL locked.

<sup>1</sup> This register is not part of framing data, but can be read by issuing a register read command of this address. This register assists support efforts giving insight into potential areas of malfunction within a failing device.

**Table 48. Extended Switch for Respiration Inputs Register (EXTENDSW) Address 0x20, Reset Value = 0x000000**

R/W	Default	Bit	Name	Switch	Function
R/W	0	23 22 21 20 19 18 17 16 15 14 13 12 11 10 9	EXT_RESP_RA to ECG1_LA EXT_RESP_RA to ECG2_LL EXT_RESP_RA to ECG3_RA EXT_RESP_RA to ECG4_V1 EXT_RESP_RA to ECG5_V2 EXT_RESP_LL to ECG1_LA EXT_RESP_LL to ECG2_LL EXT_RESP_LL to ECG3_RA EXT_RESP_LL to ECG4_V1 EXT_RESP_LL to ECG5_V2 EXT_RESP_LA to ECG1_LA EXT_RESP_LA to ECG2_LL EXT_RESP_LA to ECG3_RA EXT_RESP_LA to ECG4_V1 EXT_RESP_LA to ECG5_V2	SW1a SW1b SW1c SW1d SW1e SW2a SW2b SW2c SW2d SW2e SW3a SW3b SW3c SW3d SW3e	External respiration electrode input switch to channel electrode input (see Figure 69). <sup>1</sup> 0 = switch open. 1 = switch closed.
R/W R/W	0 0	8 7	AUX_V1 AUX_V2		V1 and V2 electrodes can be used for measurement purposes other than ECG. To achieve this, they must be disconnected from the patient VCM voltage provided from the internal common-mode buffer and, instead, connected to the internal VCM_REF level of 1.3 V. Setting the AUX_Vx bits high connects the negative input of the V1 channel amplifier to internal VCM_REF level. This allows the user to make alternative measurements on V1 relative to the VCM_REF level. If using digital lead mode, use these bits in conjunction with Bits[6:5] (NO_MATH_Vx).
R/W	0 0	6 5	NOMATH_V1 NOMATH_V2		In digital lead mode, the digital core always calculates V1' and V2' with respect to WCT (LA + LL + RA)/3. Where V1 or V2 are used for alternative measurement purposes other than ECG, this math calculation must be disabled. These bits are most likely used in conjunction with Bits[8:7] (AUX_Vx). Set NOMATH_Vx bits high to disable the math calculation in V1 and V2, respectively.
R/W	0	[4:0]	Reserved		Reserved, set to 0.

<sup>1</sup> ADAS1000 model only, ADAS1000-1/ADAS1000-2 models do not contain these EXT\_RESP\_xx pins.

Table 49. User Gain Calibration Registers (CALxx) Address 0x21 to Address 0x25, Reset Value = 0x000000

R/W	Default	Bit	Name	Function
		[31:24]	Address [7:0]	0x21: calibration LA. 0x22: calibration LL. 0x23: calibration RA. 0x24: calibration V1. 0x25: calibration V2.
R/W	0	23	USRCAL	User can choose between default calibration values or user calibration values for GAIN 0, GAIN 1, GAIN 2. Note that for GAIN 3, there is no factory calibration. 0 = default calibration values (factory calibration). 1 = user calibration values.
R/W	0	[22:12]	Reserved	Reserved, set to 0
R/W	0	[11:0]	CALVALUE	Gain calibration value. Result = data × (1 + GAIN × 2 <sup>-17</sup> ). The value read from this register is the current gain calibration value. If the USRCAL bit is set to 0, this register returns the default value for the current gain setting. 0x7FF (+2047) = ×1.0000001111111111b. 0x001 (+1) = ×1.00000000000000001b. 0x000 (0) = ×1.0000000000000000b. 0xFFF (-1) = ×0.1111111111111111b. 0x800 (-2048) = ×0.1111110000000000b.

Table 50. Read AC Lead-Off Amplitude Registers (LOAMxx) Address 0x31 to Address 35, Reset Value = 0x000000<sup>1</sup>

R/W	Default	Bit	Name	Function
		[31:24]	Address [7:0]	0x31: LA ac lead-off amplitude. 0x32: LL ac lead-off amplitude. 0x33: RA ac lead-off amplitude. 0x34: V1 ac lead-off amplitude. 0x35: V2 ac lead-off amplitude.
R/W	0	[23:16]	Reserved	Reserved.
R	0	[15:0]	LOFFAM	Measured amplitude. When ac lead-off is selected, the data is the average of the rectified 2 kHz band-pass filter with an update rate of 8 Hz and cutoff frequency at 2 Hz. The output is the amplitude of the 2 kHz signal scaled by 2/π approximately = 0.6 (average of rectified sine wave). To convert to RMS, scale the output by π/(2√2). Lead-off (unsigned). Minimum 0x0000 = 0 V. LSB 0x0001 = VREF/GAIN/2 <sup>16</sup> . Maximum 0xFFFF = VREF/GAIN.

<sup>1</sup> This register is not part of framing data, but can be read by issuing a register read command of this address.

**Table 51. Pace Width and Amplitude Registers (PACExDATA) Address 0x3A to Address 0x3C, Reset Value = 0x000000<sup>1, 2</sup>**

R/W	Default	Bit	Name	Function
		[31:24]	Address [7:0]	0x3A: PACE1DATA 0x3B: PACE2DATA 0x3C: PACE3DATA
R	0	[23:8]	Pace height	Measured pace height in signed two's complement value 0 = 0 1 = VREF/GAIN/2 <sup>16</sup> N = N × VREF/GAIN/2 <sup>16</sup>
R	0	[7:0]	Pace width	Measured pace width in 128 kHz samples N: N/128 kHz = width 12: 12/128 kHz = 93 μs 255:255/128 kHz = 2.0 ms

<sup>1</sup> These registers are not part of framing data but can be read by issuing a register read command of these addresses.

<sup>2</sup> ADAS1000 model only, ADAS1000-1/ADAS1000-2 models do not contain these features.

Table 52. Frame Header (FRAMES) Address 0x40, Reset Value = 0x800000<sup>1</sup>

R/W	Default	Bit	Name	Function
R	1	31	Marker	Header marker, set to 1 for the header.
R	0	30	Ready bit	Ready bit indicates if ECG frame data is calculated and ready for reading. 0 = ready, data frame follows. 1 = busy.
R	0	[29:28]	Overflow [1:0]	Overflow bits indicate that since the last frame read, a number of frames have been missed. This field saturates at the maximum count. The data in the frame including this header word is valid but old if the overflow bits are >0. When using skip mode (FRMCTL register (0x0A), Bits[3:2]), the overflow bit acts as a flag, where a nonzero value indicates an overflow. 00 = 0 missed. 01 = 1 frame missed. 10 = 2 frames missed. 11 = 3 or more frames missed.
R	0	27	Fault	Internal device error detected. 0 = normal operation. 1 = error condition.
R	0	26	Pace 3 detected	Pace 3 indicates pacing artifact was qualified at most recent point. 0 = no pacing artifact. 1 = pacing artifact present.
R	0	25	Pace 2 detected	Pace 2 indicates pacing artifact was qualified at most recent point. 0 = no pacing artifact. 1 = pacing artifact present.
R	0	24	Pace 1 detected	Pace 1 indicates pacing artifact was qualified at most recent point. 0 = no pacing artifact. 1 = pacing artifact present.
R	0	23	Respiration	0 = no new respiration data. 1 = respiration data updated.
R	0	22	Lead-off detected	If both dc and ac lead-off are enabled, this bit is the OR of all the ac lead-off detect flags. If only ac or dc lead-off is enabled, this bit reflects the OR of all dc and ac lead-off flags. 0 = all leads connected. 1 = one or more lead-off detected.
R	0	21	DC lead-off detected	0 = all leads connected. 1 = one or more lead-off detected.
R	0	20	ADC out of range	0 = ADC within range. 1 = ADC out of range.
	0	[19:0]	Reserved	Reserved

<sup>1</sup> If using 128 kHz data rate in frame mode, only the upper 16 bits are sent. If using the 128 kHz data rate in regular read/write mode, all 32 bits are sent.

Table 53. Frame CRC Register (CRC) Address 0x41, Reset Value = 0xFFFFFFFF<sup>1</sup>

R/W	Bit	Name	Function
R	[23:0]	CRC	Cyclic redundancy check

<sup>1</sup> The CRC register is a 32-bit word for 2 kHz and 16 kHz data rate and a 16-bit word for 128 kHz rate. See Table 22 for more details.

## EXAMPLES OF INTERFACING TO THE ADAS1000

The following examples shows register commands required to configure the ADAS1000 device into particular modes of operation and to start framing ECG data.

### Example 1: Initialize the ADAS1000 for ECG Capture and Start Streaming Data

- Write 1 configures the CMREFCTL register for CM =  $WCT = (LA + LL + RA)/3$ ; RLD is enabled onto the RLD\_OUT electrode. The shield amplifier is enabled.
- Write 2 configures the FRMCTL register to output nine words per frame/packet. The frame/packet of words consist of the header, five ECG words, pace, respiration magnitude, and lead-off. The frame is configured to always send, irrespective of ready status. The ADAS1000 is in vector format mode with a data rate of 2 kHz.
- Write 3 addresses the ECGCTL register, enabling all channels into a gain of 1.4, low noise mode, and differential input, which configures the device for analog lead mode. This register also configures the device as a master, using the external crystal as the input source to the XTALx pins. The ADAS1000 is also put into conversion mode in this write.
- Write 4 issues the read command to start putting the converted data out on the SDO pin.
- Continue to issue SCLK cycles to read the converted data at the configured packet data rate (2 kHz). The SDI input should be held low when reading back the conversion data because any commands issued to the interface during read of frame/packet are understood to be a change of configuration data and will stop the ADC conversions to allow the interface to process the new command.

### Example 2: Enable Respiration and Stream Conversion Data

- Write 1 configures the RESPCTL register with a 56 kHz respiration drive signal, gain = 1, driving out through the respiration capacitors and measuring on Lead I.
- Write 2 issues the read command to start putting the converted data out on the SDO pin.
- Continue to issue SCLK cycles to read the converted data at the configured packet data rate.
- Note that this example assumes that the FRMCTL register has already been configured such that the respiration magnitude is available in the data frame, as arranged in Write 2 of Example 1.

### Example 3: DC Lead-Off and Stream Conversion Data

- Write 1 configures the LOFFCTL register with a dc lead-off enabled for a lead-off current of 50 nA.
- Write 2 issues the read command to start putting the converted data out on the SDO pin.
- Continue to issue SCLK cycles to read the converted data at the configured packet data rate.
- Note that this example assumes that the FRMCTL register has already been configured such that the dc lead-off word is available in the data frame, as arranged in Write 2 of Example 1.

**Table 54. Example 1: Initialize the ADAS1000 for ECG Capture and Start Streaming Data**

Write Command	Register Addressed	Read/Write Bit	Register Address	Data	32-Bit Write Command
Write 1	CMREFCTL	1	000 0101	1110 0000 0000 0000 0000 1011	0x85E0000B
Write 2	FRMCTL	1	000 1010	0000 0111 1001 0110 0000 0000	0x8A079600
Write 3	ECGCTL	1	000 0001	1111 1000 0000 0100 1010 1110	0x81F804AE
Write 4	FRAMES	0	100 0000	0000 0000 0000 0000 0000 0000	0x40000000

**Table 55. Example 2: Enable Respiration and Stream Conversion Data**

Write Command	Register Addressed	Read/Write Bit	Register Address	Data	32-Bit Write Command
Write 1	RESPCTL	1	000 0011	0000 0000 0010 0000 1001 1001	0x83002099
Write 2	FRAMES	0	100 0000	0000 0000 0000 0000 0000 0000	0x40000000

**Table 56. Example 3: Enable DC Lead-Off and Stream Conversion Data**

Write Command	Register addressed	Read/Write Bit	Register Address	Data	32-Bit Write Command
Write 1	LOFFCTL	1	000 0010	0000 0000 0000 0000 0001 0101	0x82000015
Write 2	FRAMES	0	100 0000	0000 0000 0000 0000 0000 0000	0x40000000



**Example 4: Configure 150 Hz Test Tone Sine Wave on Each ECG Channel and Stream Conversion Data**

1. Write 1 configures the CMREFCTL register to VCM\_REF = 1.3 V (no electrodes contribute to VCM). RLD is enabled to RLD\_OUT, and the shield amplifier enabled.
2. Write 2 addresses the TESTTONE register to enable the 150 Hz sine wave onto all electrode channels.
3. Write 3 addresses the FILTCTL register to change the internal low-pass filter to 250 Hz to ensure that the 150 Hz sine wave can pass through.
4. Write 4 configures the FRMCTL register to output nine words per frame/packet. The frame/packet of words consists of the header and five ECG words, pace, respiration magnitude, and lead-off. The frame is configured to always send, irrespective of ready status. The ADAS1000 is in electrode format mode with a data rate of 2 kHz. Electrode format is required to see the test tone signal correctly on each electrode channel.
5. Write 5 addresses the ECGCTL register, enabling all channels into a gain of 1.4, low noise mode. It configures the device as a master and driven from the XTAL input source. The ADAS1000 is also put into conversion mode in this write.
6. Write 6 issues the read command to start putting the converted data out on the SDO pin.
7. Continue to issue SCLK cycles to read the converted data at the configured packet data rate.

**Example 5: Enable Pace Detection and Stream Conversion Data**

1. Write 1 configures the PACECTL register with all three pace detection instances enabled, PACE1EN detecting on Lead II, PACE2EN detecting on Lead I, and PACE3EN detecting on Lead aVF. The pace width filter and validation filters are also enabled.
2. Write 2 issues the read command to start putting the converted data out on the SDO pin.
3. Continue to issue SCLK cycles to read the converted data at the configured packet data rate. When a valid pace is detected, the detection flags are confirmed in the header word and the PACEDATA register contains information on the width and height of the measured pulse from each measured lead.
4. Note that the PACEAMPTH register default setting is 0x242424, setting the amplitude of each of the pace instances to 1.98 mV/gain.
5. Note that this example assumes that the FRMCTL register has already been configured such that the PACEDATA word is available in the data frame, as arranged in Write 2 of Example 1.

**Table 57. Example 4: Configure 150 Hz Test Tone Sine Wave on Each ECG Channel and Stream Conversion Data**

Write Command	Register Addressed	Read/Write Bit	Register Address	Data	32-Bit Write Command
Write 1	CMREFCTL	1	000 0101	0000 0000 0000 0000 0000 1011	0x8500000B
Write 2	TESTTONE	1	000 1000	1111 1000 0000 0000 0000 1101	0x88F8000D
Write 3	FILTCTL	1	000 1011	0000 0000 0000 0000 0000 1000	0x8B000008
Write 4	FRMCTL	1	000 1010	0000 0111 1001 0110 0001 0000	0x8A079610
Write 5	ECGCTL	1	000 0001	1111 1000 0000 0000 1010 1110	0x81F800AE
Write 6	FRAMES	0	100 0000	0000 0000 0000 0000 0000 0000	0x40000000

**Table 58. Example 5: Enable Pace Detection and Stream Conversion Data**

Write Command	Register Addressed	Read/Write Bit	Register Address	Data	32-Bit Write Command
Write 1	PACECTL	1	000 0100	0000 0000 0000 1111 1000 1111	0x84000F8F
Write 2	FRAMES	0	100 0000	0000 0000 0000 0000 0000 0000	0x40000000

## Example 6: Writing to Master and Slave Devices and Streaming Conversion Data

### Slave Configuration

- Write 1 configures the FRMCTL register to output seven words per frame/packet. The frame/packet of words consist of the header, five ECG words, and lead-off. The frame is configured to always send, irrespective of ready status. The slave ADAS1000-2 is in electrode mode format with a data rate of 2 kHz.
- Write 2 configures the CMREFCTL register to receive an external common mode from the master.
- Write 3 addresses the ECGCTL register, enabling all channels into a gain of 1.4, low noise mode. It configures the device as a slave, in gang mode and driven from the CLK\_IN input source (derived from master ADAS1000). The ADAS1000-2 slave is also put into conversion mode in this write, but waits for the SYNC\_GANG signal from the master device before it starts converting.

### Master Configuration

- Write 4 configures the FRMCTL register to output nine words per frame/packet (note that this differs from the number of words in a frame available from the slave device). The frame/packet of words consists of the header, five ECG words, pace, respiration magnitude, and lead-off. In this example, the frame is configured to always send irrespective of ready status. The master, ADAS1000, is in vector mode format with a data rate of 2 kHz. Similar to the slave device, the master could be configured for electrode mode; the host controller would then be required to make the lead calculations.
- Write 5 configures the CMREFCTL register for  $CM = WCT = (LA + LL + RA)/3$ ; RLD is enabled onto RLD\_OUT electrode. The shield amplifier is enabled. The  $CM = WCT$  signal is driven out of the master device (CM\_OUT) into the slave device (CM\_IN).
- Write 6 addresses the ECGCTL register, enabling all channels into a gain of 1.4, low noise mode. It configures the device as a master in gang mode and driven from the XTAL input source. The ADAS1000 master is set to differential input, which places it in analog lead mode. This ECGCTL register write puts the master into conversion mode, where the device sends an edge on the SYNC\_GANG pin to the slave device to trigger the simultaneous conversions of both devices.
- Write 7 issues the read command to start putting the converted and decimated data out on the SDO pin.
- Continue to issue SCLK cycles to read the converted data at the configured packet data rate.

Table 59. Example 6: Writing to Master and Slave Devices and Streaming Conversion Data

Device	Write Command	Register Addressed	R/W	Register Address	Data	32-Bit Write Command
Slave	Write 1	FRMCTL	1	000 1010	0000 0111 1111 0110 0001 0000	0x8A07F610
	Write 2	CMREFCTL	1	000 0101	0000 0000 0000 0000 0000 0100	0x85000004
	Write 3	ECGCTL	1	000 0001	1111 1000 0000 0000 1101 1110	0x81F800DE
Master	Write 4	FRMCTL	1	000 1010	0000 0111 1001 0110 0000 0000	0x8A079600
	Write 5	CMREFCTL	1	000 0101	1110 0000 0000 0000 0000 1011	0x85E0000B
	Write 6	ECGCTL	1	000 0001	1111 1000 0000 0100 1011 1110	0x81F804BE
	Write 7	FRAMES	0	100 0000	0000 0000 0000 0000 0000 0000	0x40000000

**SOFTWARE FLOWCHART**

Figure 81 shows a suggested sequence of steps to be taken to interface to multiple ADAS1000/ADAS1000-1/ADAS1000-2 devices.

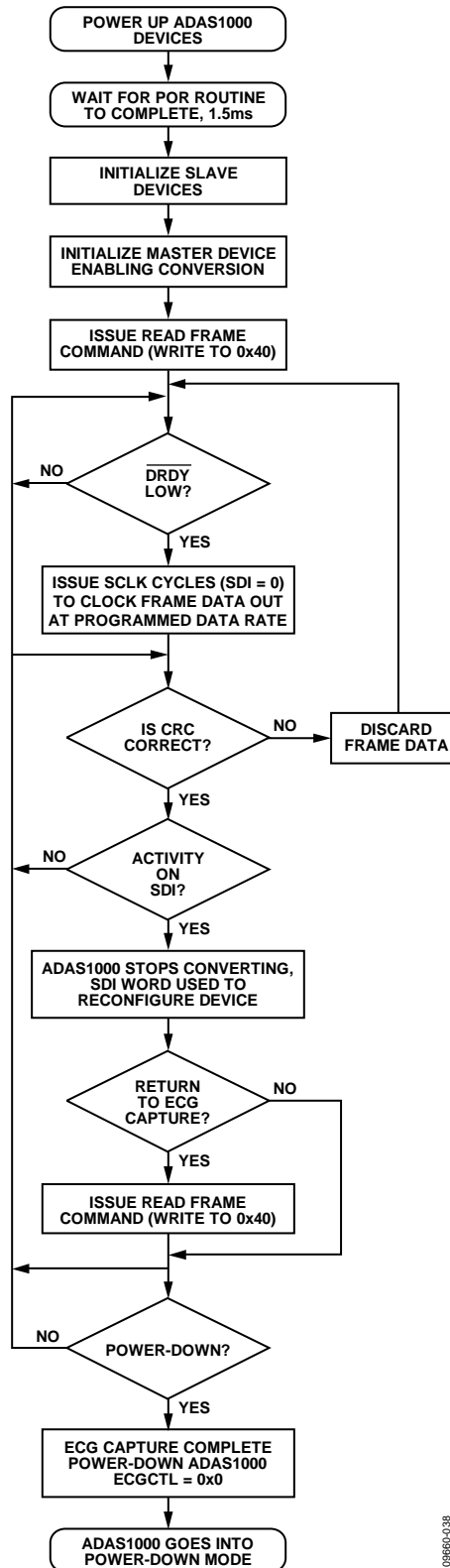

09660-038

Figure 81. Suggested Software Flowchart for Interfacing to Multiple ADAS1000/ADAS1000-1/ADAS1000-2 Devices

## POWER SUPPLY, GROUNDING, AND DECOUPLING STRATEGY

The [ADAS1000/ADAS1000-1/ADAS1000-2](#) should have ample supply decoupling of 0.01  $\mu\text{F}$  on each supply pin located as close to the device pin as possible, ideally right up against the device. In addition, there should be one 4.7  $\mu\text{F}$  capacitor for each of the power domains, AVDD and IOVDD, again located as close to the device as possible. IOVDD is best split from AVDD due to its noisy nature.

Similarly, the ADCVDD and DVDD power domains each require one 2.2  $\mu\text{F}$  capacitor with ESR in the range of 0.5  $\Omega$  to 2  $\Omega$ . The ideal location for each 2.2  $\mu\text{F}$  capacitor is dependent on package type. For the LQFP package and DVDD decoupling, the 2.2  $\mu\text{F}$  capacitor is best placed between Pin 30 and Pin 31, while for ADCVDD, the 2.2  $\mu\text{F}$  capacitor should be placed between Pin 55 and Pin 56. Similarly for the LFCSP package, the DVDD 2.2  $\mu\text{F}$  capacitor is ideal between Pin 43 and Pin 44, and between Pin 22 and Pin 23 for ADCVDD. A 0.01  $\mu\text{F}$  capacitor is recommended for high frequency decoupling at each pin. The 0.01  $\mu\text{F}$  capacitors should have low effective series resistance (ESR) and effective series inductance (ESL), such as the common ceramic capacitors that provide a low impedance path to ground at high frequencies to handle transient currents due to internal logic switching.

Digital lines running under the device should be avoided because these couple noise onto the device. The analog ground plane should be allowed to run under the device to avoid noise coupling. The power supply lines should use as large a trace as possible to provide low impedance paths and reduce the effects of glitches on the power supply line. Fast switching digital signals should be shielded with digital ground to avoid radiating noise to other parts of the board and should never be run near the reference inputs. It is essential to minimize noise on VREF lines. Avoid crossover of digital and analog signals. Traces on opposite sides of the board should run at right angles to each other. This reduces the effects of feedthrough throughout the board. As is the case for all thin packages, take care to avoid flexing the package and to avoid a point load on the surface of this package during the assembly process.

During layout of board, ensure that bypass capacitors are placed as close to the relevant pin as possible, with short, wide traces ideally on the topside.

### AVDD

While the [ADAS1000/ADAS1000-1/ADAS1000-2](#) are designed to operate from a wide supply rail, 3.15 V to 5.5 V, the performance is similar over the full range, but overall power increases with increasing voltage.

## ADCVDD AND DVDD SUPPLIES

The AVDD supply rail powers the analog blocks in addition to the internal 1.8 V regulators for the ADC and the digital core. If using the internal regulators, connect the VREG\_EN pin to AVDD and then use the ADCVDD and DVDD pins for decoupling purposes.

The DVDD regulator can be used to drive other external digital circuitry as required; however the ADCVDD pin is purely provided for bypassing purposes and does not have available current for other components.

Where overall power consumption must be minimized, using external 1.8 V supply rails for both ADCVDD and DVDD would provide a more efficient solution. The ADCVDD and DVDD inputs have been designed to be driven externally and the internal regulators may be disabled by tying VREG\_EN pin directly to ground.

## UNUSED PINS/PATHS

In applications where not all ECG paths or functions might be used, the preferred method of biasing the different functions is as follows:

- Unused ECG paths power up disabled. For low power operation, they should be kept disabled throughout operation. Ideally, these pins should be connected to RLD\_OUT if not being used.
- Unused external respiration inputs can be tied to ground if not in use.
- If unused, the shield driver can be disabled and output left to float.
- CM\_OUT, CAL\_DAC\_IO,  $\overline{\text{DRDY}}$ , GPIOx, CLK\_IO, SYNC\_GANG can be left open.

## LAYOUT RECOMMENDATIONS

To maximize CMRR performance, pay careful attention to the ECG path layout for each channel. All channels should be identical to minimize difference in capacitance across the paths.

Place all decoupling as close to the [ADAS1000/ADAS1000-1/ADAS1000-2](#) devices as possible, with an emphasis on ensuring that the VREF decoupling be prioritized, with VREF decoupling on the same side as the [ADAS1000/ADAS1000-1/ADAS1000-2](#) devices, where possible.

OUTLINE DIMENSIONS

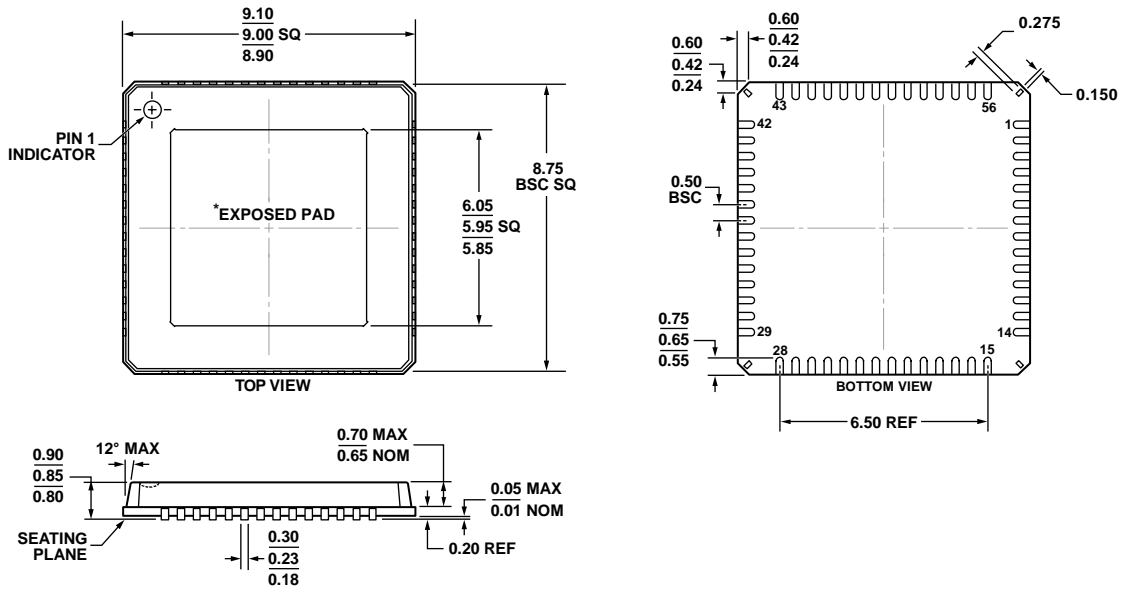

\*FOR PROPER CONNECTION OF THE EXPOSED PAD, REFER TO THE PIN CONFIGURATIONS AND FUNCTION DESCRIPTIONS SECTION OF THIS DATA SHEET.

Figure 82. 56-Lead, Lead Frame Chip Scale Package [LFCSP\_VQ]  
 9 mm × 9 mm Body, Very Thin Quad  
 (CP-56-7)  
 Dimensions shown in millimeters

06-20-2012-A

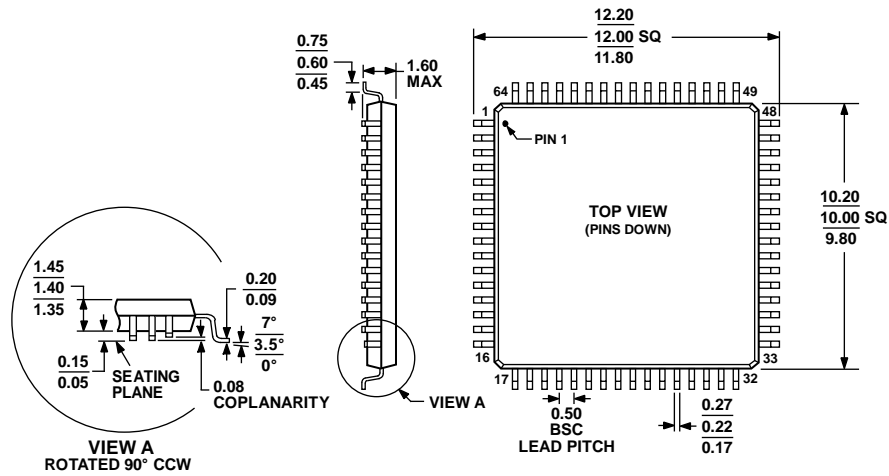

COMPLIANT TO JEDEC STANDARDS MS-026-BCD

Figure 83. 64-Lead Low Profile Quad Flat Package [LQFP]  
 (ST-64-2)  
 Dimensions shown in millimeters

081706-A

## ORDERING GUIDE

Model <sup>1</sup>	Description	Temperature Range	Package Description	Package Option
ADAS1000BSTZ	5 ECG Channels, Pace Algorithm, Respiration Circuit	−40°C to +85°C	64-Lead LQFP	ST-64-2
ADAS1000BSTZ-RL	5 ECG Channels, Pace Algorithm, Respiration Circuit	−40°C to +85°C	64-Lead LQFP	ST-64-2
ADAS1000BCPZ	5 ECG Channels, Pace Algorithm, Respiration Circuit	−40°C to +85°C	56-Lead LFCSP_VQ	CP-56-7
ADAS1000BCPZ-RL	5 ECG Channels, Pace Algorithm, Respiration Circuit	−40°C to +85°C	56-Lead LFCSP_VQ	CP-56-7
ADAS1000-1BCPZ	5 ECG Channels	−40°C to +85°C	56-Lead LFCSP_VQ	CP-56-7
ADAS1000-1BCPZ-RL	5 ECG Channels	−40°C to +85°C	56-Lead LFCSP_VQ	CP-56-7
ADAS1000-2BSTZ	Companion for Gang Mode	−40°C to +85°C	64-Lead LQFP	ST-64-2
ADAS1000-2BSTZ-RL	Companion for Gang Mode	−40°C to +85°C	64-Lead LQFP	ST-64-2
ADAS1000-2BCPZ	Companion for Gang Mode	−40°C to +85°C	56-Lead LFCSP_VQ	CP-56-7
ADAS1000-2BCPZ-RL	Companion for Gang Mode	−40°C to +85°C	56-Lead LFCSP_VQ	CP-56-7
EVAL-ADAS1000SDZ	ADAS1000 Evaluation Board		Evaluation Kit <sup>2</sup>	
EVAL-SDP-CB1Z	System Demonstration Board (SDP), used as a controller board for data transfer via USB interface to PC		Controller Board <sup>3</sup>	

<sup>1</sup> Z = RoHS Compliant Part.

<sup>2</sup> This evaluation kit consists of ADAS1000BSTZ × 2 for up to 12-lead configuration. Because the [ADAS1000](#) contains all features, it is the evaluation vehicle for all [ADAS1000](#) variants.

<sup>3</sup> This board allows a PC to control and communicate with all Analog Devices evaluation boards ending in the SD designator.

**NOTES**

NOTES