

Features

Parameter	Symbol	Value	Unit
Max supply voltage	V_{CC}	41	V
Operating voltage range	V_{CC}	4.5 to 28	V
Max On-State resistance	R_{ON}	50	m Ω
Current limitation (typ)	I_{LIMH}	27	A
Off-state supply current	I_S	2	$\mu A^{(1)}$

1. Typical value with all loads connected.

- Simple single IC application board dedicated for VND5E050K-E
- Provides thermal heat-sinking for ease of use in prototyping
- Provides electrical connectivity for easy prototyping

Description

EV-VND5E050K provides you an easy way to connect ST's surface mounted VIPower® drivers into your existing prototype circuitry. This evaluation board comes pre-assembled with VND5E050K-E high-side driver.

The VND5E050K-E is a double channel high-side driver manufactured using ST proprietary VIPower M0-5 technology and housed in PowerSSO-24 package. The VND5E050K-E is designed to drive automotive grounded loads, providing protection, diagnostics and easy 3 V and 5 V CMOS-compatible interface with any microcontroller.

The device integrates advanced protective functions such as load current limitation, inrush and overload active management by power limitation, overtemperature shut-off with auto-restart and overvoltage active clamp. A dedicated active low digital status pin is associated with

every output channel that provides enhanced diagnostic functions including fast detection of overload and short-circuit to ground, overtemperature indication, short-circuit to V_{CC} diagnosis and ON-state and OFF-state open-load detection.

The diagnostic feedback of the whole device can be disabled by pulling the STAT_DIS pin up, thus allowing wired-ORing with similar devices.

Figure 1. VND5E050K evaluation board

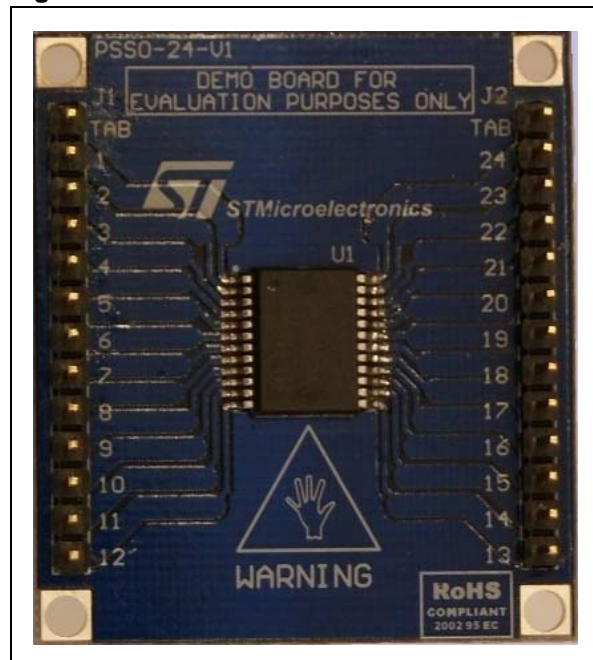

Table 1. Device summary

Order code	Reference
EV-VND5E050K	VND5E050K evaluation board

1 Design recommendations

This evaluation board provides mounting solution and some heat sinking capability for prototype development, but there are still external components that are required to make these devices work in any application. For further information on how the evaluation board has to be used you can refer to the AN4212 (see [Appendix A: Reference documents](#)).

[Figure 2](#) illustrates the necessary components for any application.

Figure 2. VND5E050K evaluation board

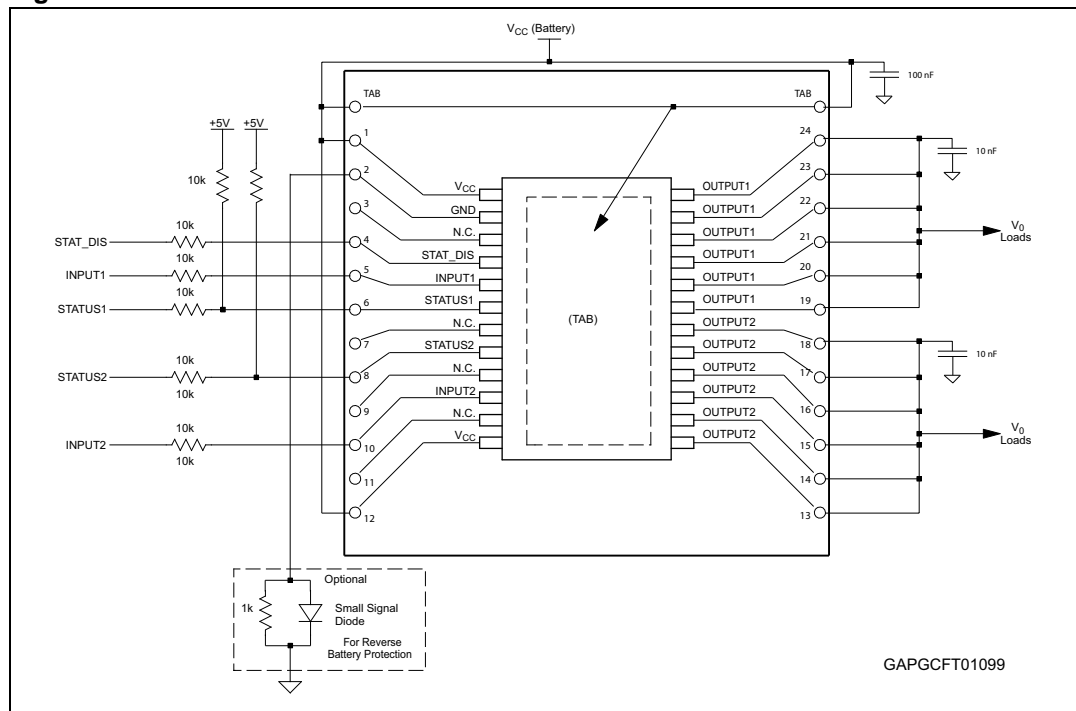

ST has produced a user manual for safe designs using ST’s VIPower devices. This is UM1556 (see [Appendix A: Reference documents](#)). UM1556 is a VIPower Hardware design guide that provides all necessary information to successfully design your circuit using our VIPower drivers.

All designs have different needs and requirements. Whatever design you decide to use, it will still need to be verified in order to meet your application specifications. ST implies no guarantee or warranty (see [Appendix A: Reference documents](#)).

2 Thermal data

Table 2. VND5E050K-E thermal data

Symbol	Parameter	Max. value	Unit
$R_{thj-amb}$	Thermal resistance junction-ambient (MAX)	29.5	°C/W

Table 3. PCB specifications

Parameter	Value	Unit
Board dimensions	38 x 43	mm
Number of Cu layer	2	—
Layer Cu thickness	70	μm
Board finish thickness	1.6 +/- 10%	mm
Board Material	FR4	—
Thermal vias separation	1.2	mm
Thermal vias diameter	0.3 /- 0.08	mm

3 Board connector reference

Figure 3. Board layout

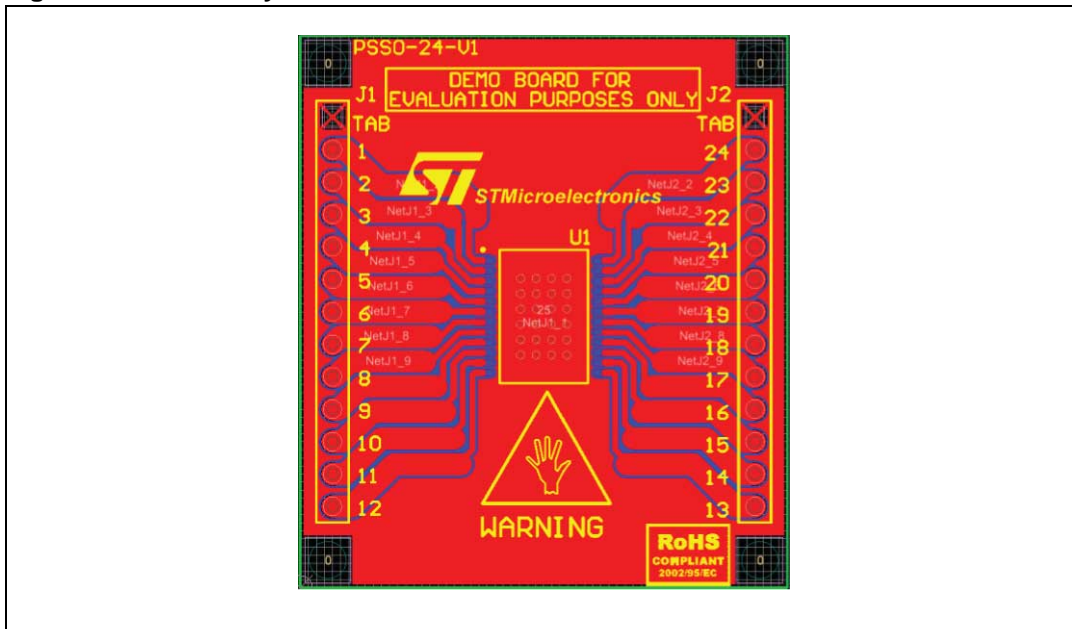

Table 4. Board connector specification

Connector	Board lead number	Device pin function ⁽¹⁾
J1	TAB	V _{CC}
J1	1	V _{CC}
J1	2	GND
J1	3	N.C.
J1	4	STAT_DIS
J1	5	INPUT1
J1	6	STATUS1
J1	7	N.C.
J1	8	STATUS2
J1	9	N.C.
J1	10	INPUT2
J1	11	N.C.
J1	12	V _{CC}
J2	TAB	V _{CC}
J2	13	OUTPUT2
J2	14	OUTPUT2
J2	15	OUTPUT2

Table 4. Board connector specification (continued)

Connector	Board lead number	Device pin function ⁽¹⁾
J2	16	OUTPUT2
J2	17	OUTPUT2
J2	18	OUTPUT2
J2	19	OUTPUT1
J2	20	OUTPUT1
J2	21	OUTPUT1
J2	22	OUTPUT1
J2	23	OUTPUT1
J2	24	OUTPUT1

1. For further clarification on pin functions please refer to the related datasheet (see [Appendix A: Reference documents](#)).

4 Package information

4.1 ECOPACK[®] packages

In order to meet environmental requirements, ST offers these devices in different grades of ECOPACK[®] packages, depending on their level of environmental compliance. ECOPACK[®] specifications, grade definitions and product status are available at: www.st.com.

ECOPACK[®] is an ST trademark.

Appendix A Reference documents

1. Double channel high side driver for automotive applications (VND5E050K-E, DocID 14472)
2. VIPower M0-5 and M0-5Enhanced high-side drivers (UM1556, DocID 023520)
3. PowerSSO-24 devices evaluation board (AN4212, DocID 023983)
4. Evaluation Product Licence Agreement on www.st.com

Revision history

Table 5. Document revision history

Date	Revision	Changes
29-Nov-2012	1	Initial release.
16-Sep-2013	2	Updated disclaimer.

Please Read Carefully:

Information in this document is provided solely in connection with ST products. STMicroelectronics NV and its subsidiaries ("ST") reserve the right to make changes, corrections, modifications or improvements, to this document, and the products and services described herein at any time, without notice.

All ST products are sold pursuant to ST's terms and conditions of sale.

Purchasers are solely responsible for the choice, selection and use of the ST products and services described herein, and ST assumes no liability whatsoever relating to the choice, selection or use of the ST products and services described herein.

No license, express or implied, by estoppel or otherwise, to any intellectual property rights is granted under this document. If any part of this document refers to any third party products or services it shall not be deemed a license grant by ST for the use of such third party products or services, or any intellectual property contained therein or considered as a warranty covering the use in any manner whatsoever of such third party products or services or any intellectual property contained therein.

UNLESS OTHERWISE SET FORTH IN ST'S TERMS AND CONDITIONS OF SALE ST DISCLAIMS ANY EXPRESS OR IMPLIED WARRANTY WITH RESPECT TO THE USE AND/OR SALE OF ST PRODUCTS INCLUDING WITHOUT LIMITATION IMPLIED WARRANTIES OF MERCHANTABILITY, FITNESS FOR A PARTICULAR PURPOSE (AND THEIR EQUIVALENTS UNDER THE LAWS OF ANY JURISDICTION), OR INFRINGEMENT OF ANY PATENT, COPYRIGHT OR OTHER INTELLECTUAL PROPERTY RIGHT.

ST PRODUCTS ARE NOT DESIGNED OR AUTHORIZED FOR USE IN: (A) SAFETY CRITICAL APPLICATIONS SUCH AS LIFE SUPPORTING, ACTIVE IMPLANTED DEVICES OR SYSTEMS WITH PRODUCT FUNCTIONAL SAFETY REQUIREMENTS; (B) AERONAUTIC APPLICATIONS; (C) AUTOMOTIVE APPLICATIONS OR ENVIRONMENTS, AND/OR (D) AEROSPACE APPLICATIONS OR ENVIRONMENTS. WHERE ST PRODUCTS ARE NOT DESIGNED FOR SUCH USE, THE PURCHASER SHALL USE PRODUCTS AT PURCHASER'S SOLE RISK, EVEN IF ST HAS BEEN INFORMED IN WRITING OF SUCH USAGE, UNLESS A PRODUCT IS EXPRESSLY DESIGNATED BY ST AS BEING INTENDED FOR "AUTOMOTIVE, AUTOMOTIVE SAFETY OR MEDICAL" INDUSTRY DOMAINS ACCORDING TO ST PRODUCT DESIGN SPECIFICATIONS. PRODUCTS FORMALLY ESCC, QML OR JAN QUALIFIED ARE DEEMED SUITABLE FOR USE IN AEROSPACE BY THE CORRESPONDING GOVERNMENTAL AGENCY.

Resale of ST products with provisions different from the statements and/or technical features set forth in this document shall immediately void any warranty granted by ST for the ST product or service described herein and shall not create or extend in any manner whatsoever, any liability of ST.

ST and the ST logo are trademarks or registered trademarks of ST in various countries.

Information in this document supersedes and replaces all information previously supplied.

The ST logo is a registered trademark of STMicroelectronics. All other names are the property of their respective owners.

© 2013 STMicroelectronics - All rights reserved

STMicroelectronics group of companies

Australia - Belgium - Brazil - Canada - China - Czech Republic - Finland - France - Germany - Hong Kong - India - Israel - Italy - Japan - Malaysia - Malta - Morocco - Philippines - Singapore - Spain - Sweden - Switzerland - United Kingdom - United States of America

www.st.com