



MAP9000

High Voltage AC LED Driver

MAP9000 – High Voltage AC LED Driver

General Description

The MAP9000 is LED Driver which has high input voltage ranged from 90V to 270V. It can drive several series LEDs from rectified AC voltage.

The MAP9000 can achieve min 90% efficiency, 0.95 or higher power factor and low total harmonic distortion less than 20%.

The MAP9000 has higher LED current drive capability up to 180mA and the current can be adjustable with external resistors.

The MAP9000 is available in 6X6mm QFN 12Leads with Halogen-free (fully RoHS compliant).

For more information, please contact local MagnaChip sales office in world-wide or visit MagnaChip's website.

Features

- Triac dimming (110Vac/120Vac only)
- Flicker-free
- EMI improvement
- Power variation : $\pm 15\%$
- Current variation: $\pm 6\%$
- Higher power factor : > 0.95
- Higher light efficiency : $> 90\%$
- Lower total harmonic distortion : $< 20\%$
- Higher current drive capability
Up to 180mA

Applications

- AC LED Driver
- Lighting equipment
- LED Driver Power Supplies

Ordering Information

Part Number	Top Marking	Ambient Temperature Range	Package	RoHS Status
MAP9000QNRH	MAP9000	-30°C to +85°C	6X6mm QFN 12Leads	Halogen Free

Typical Application

- AC Direct

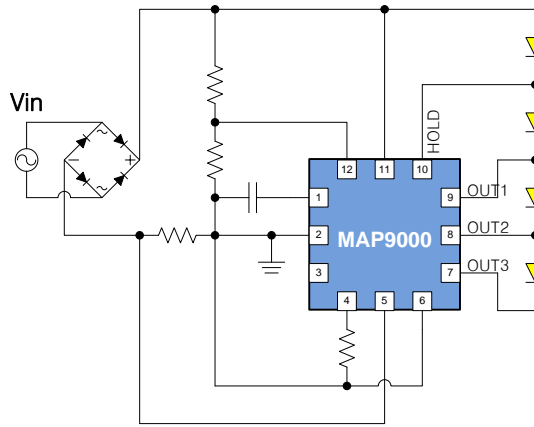

- Triac Dimming (110Vac/120Vac only)

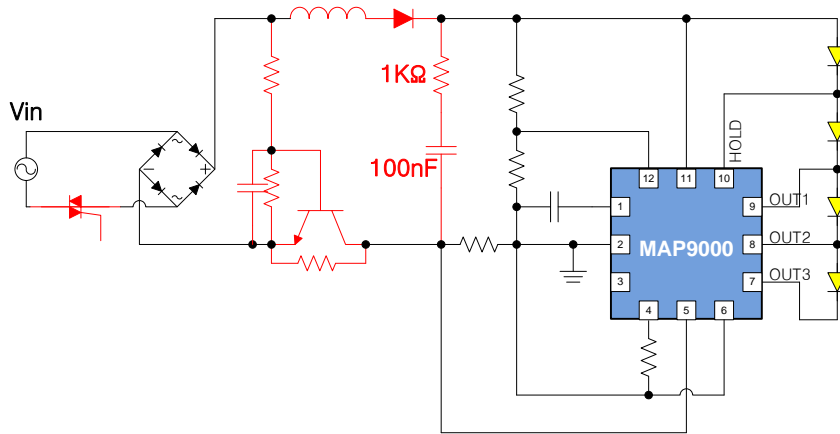

- Flicker-free

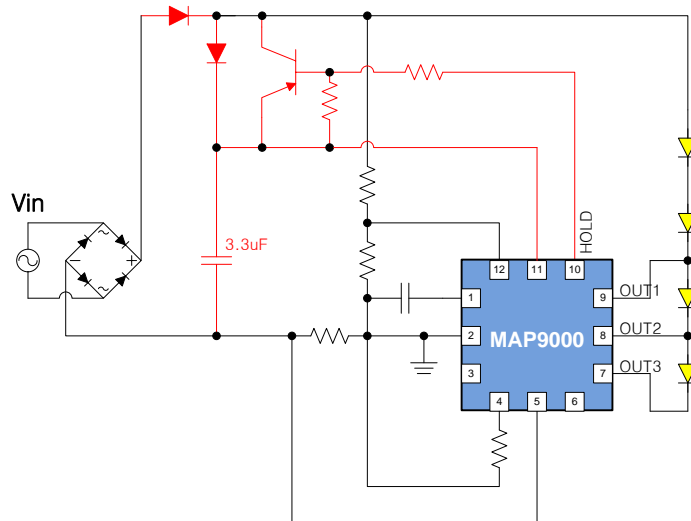

Pin Configuration & Description

- Pin Configuration

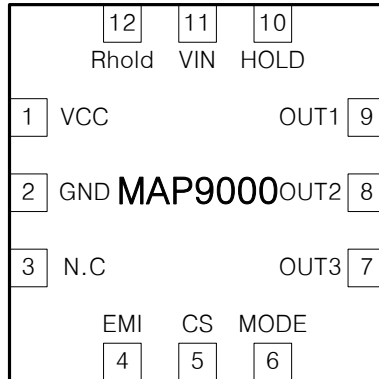

- Pin Description

Pin		Descriptions
1	VCC	VCC
2	GND	Ground
3	N.C	No Connection
4	EMI	EMI improvement
5	CS	Current sensing
6	MODE	Flicker-free mode
7	OUT3	Output – 3
8	OUT2	Output – 2
9	OUT1	Output – 1
10	HOLD	Holding-up current
11	VIN	VCC charging
12	Rhold	HOLD turn-on voltage

Functional Block Diagram

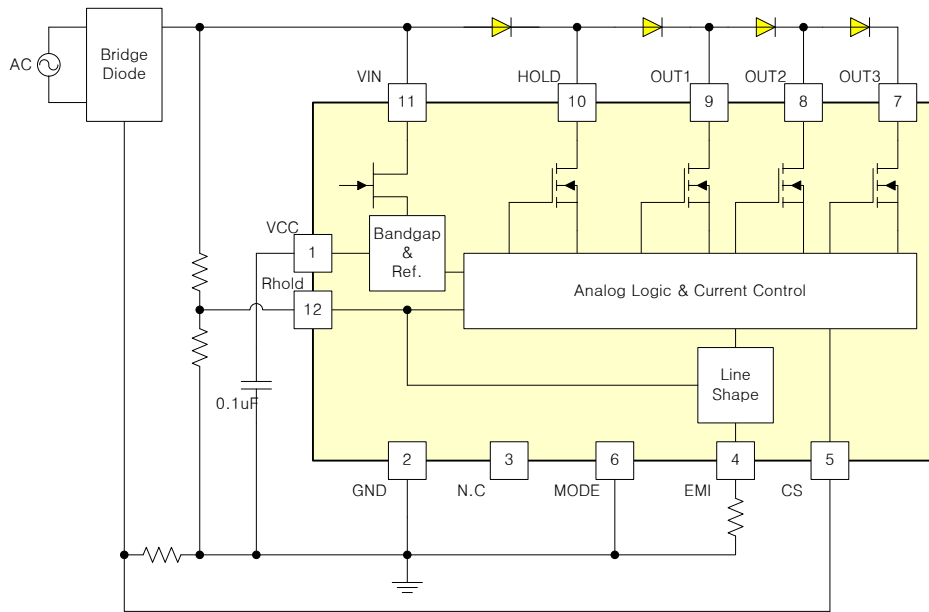

Absolute Maximum Ratings

PARAMETER		VALUE	UNIT
VIN		500	V
HOLD, OUT1, OUT2, OUT3		-0.3 ~ 500	V
EMI, Rhold		-0.3 ~ 6	V
VCC		20	V
Operating Temperature Range		-40 ~ 125	°C
Junction Temperature Range		-40 ~ 150	°C
Storage Temperature Range		-65 ~ 150	°C
Lead temperature(soldering, 10sec)		260	°C
ESD Susceptibility	HBM (All Pins except VCC), (Note 1)	2000	V
	HBM VIN	TBD	
	MM (All Pins except VCC), (Note 2)	200	V
	MM VIN	TBD	
	CDM (All Pins except VCC), (Note 3)	1000	V
	CDM VIN	TBD	

Note 1: ESD tested per JESD22A-114.

Note 2: ESD tested per JESD22A-115.

Note 3: ESD tested per JESD22C-101E

Thermal Resistance

PARAMETER		VALUE	UNIT
Thermal Resistance (θ_{JA}) , (Note4)	6X6mm QFN 12Leads	63	°C/W
Thermal Resistance (θ_{JT}) , (Note5)		TBD	°C/W

Note 4: Multi-layer PCB based on JEDEC standard (JESD51-7)

Note 5: Metal PCB based on Seoul Semiconductor

Electrical Characteristics

Ta = 25°C, CS Resistance = 6.8Ω unless otherwise specified

SYMBOL	PARAMETER	TEST CONDITION	MIN	TYP	MAX	UNIT
Supply						
V _{VIN}	Input voltage range	Note 6	50		500	V
V _{VCC}	Operating voltage		-	15	-	V
I _{VCC}	Input Current		300	600	900	uA
Driver Section						
R _{hold}	R _{hold} reference voltage	V _{VIN} = 200V, V _{GNND} = 0V		5.2		V
I _{D Leak}	Driver Leakage current	V _{VIN} = 200V, V _{GNND} = 0V, HOLD & OUT1 ~ 3 = 400V	-	-	10	uA
I _{HOLD}	HOLD current	V _{VIN} = 200V, HOLD = 40V	-	85	-	mA
I _{OUT1}	Driver 1 current	V _{VIN} = 200V, OUT1 = 40V	-	130	-	mA
I _{OUT2}	Driver 2 current	V _{VIN} = 200V, OUT2 = 40V	-	160	-	mA
I _{OUT3}	Driver 3 current	V _{VIN} = 200V, OUT3 = 40V	-	185	-	mA

Note 6: Stress beyond the maximum ratings listed above may incur permanent damage to the device. Operating above the recommended conditions for extended time may stress the device and affect device reliability. Also the device may not operate normally above the recommended operating conditions. These are stress ratings only.

Typical Operating Characteristics

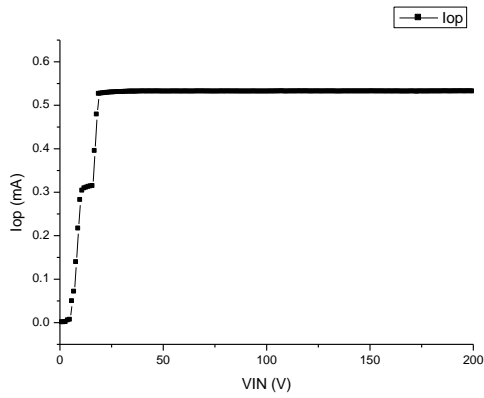

Operate Current Vs. Input Voltage

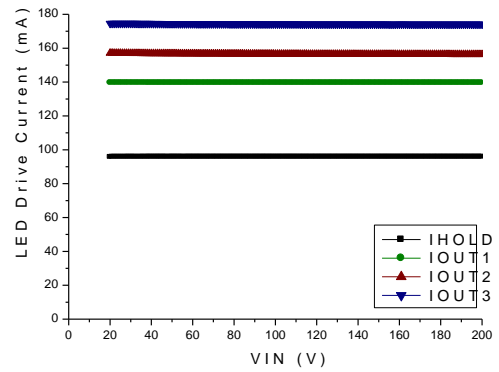

LED Drive current Vs. Input Voltage

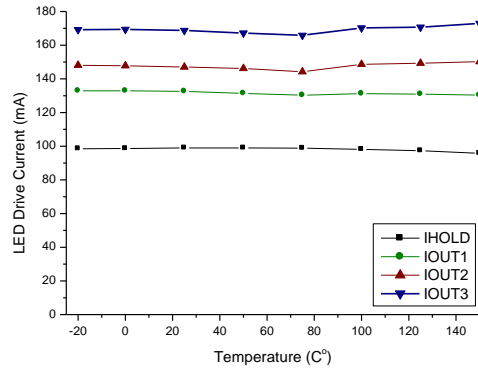

Operate Current Vs. temperature

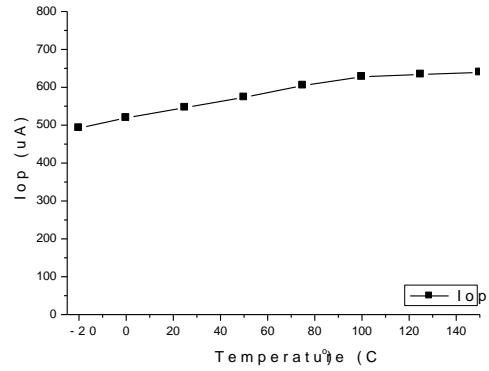

LED Drive current Vs. temperature

Physical Dimensions

1) 6X6mm QFN 12leads

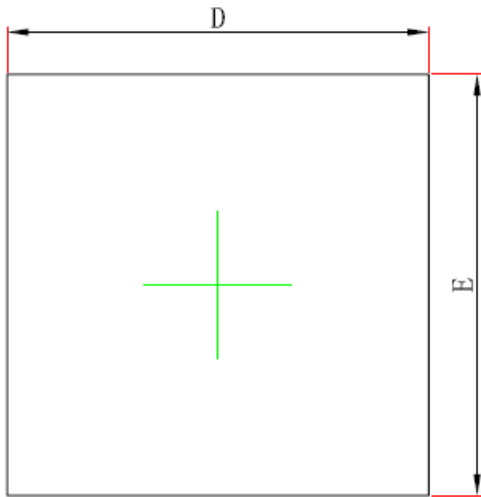

TOP VIEW

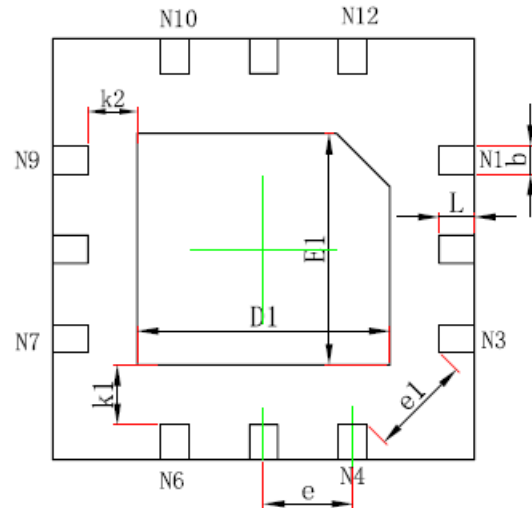

BOTTOM VIEW

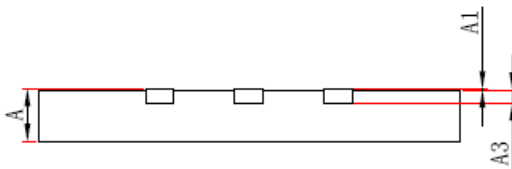

SIDE VIEW

Symbol	Dimensions In Millimeters		Dimensions In Inches	
	Min.	Max.	Min.	Max.
A	0.700/0.800	0.800/0.900	0.028/0.031	0.031/0.035
A1	0.000	0.050	0.000	0.002
A3	0.203REF.		0.008REF.	
D	5.950	6.050	0.234	0.238
E	5.950	6.050	0.234	0.238
D1	3.500	3.700	0.138	0.146
E1	3.200	3.400	0.126	0.134
k1	0.850REF.		0.033REF.	
k2	0.700REF.		0.028REF.	
b	0.350	0.450	0.014	0.018
e	1.270TYP.		0.050TYP.	
e1	1.457TYP.		0.057TYP.	
L	0.424	0.576	0.017	0.023

MagnaChip Semiconductor Ltd. doesn't not recommend the use of its products in hostile environments, including, without limitation, aircraft, nuclear power generation, medical appliances, and devices or systems in which malfunction of any product can reasonably be expected to result in a personal injury. Seller's customers using or selling Seller's products for use in such applications do so at their own risk and agree to fully defend and indemnify Seller.

MagnaChip reserves the right to change the specifications and circuitry without notice at any time. **MagnaChip** does not consider responsibility for use of any circuitry other than circuitry entirely included in a **MagnaChip** product.

 is a registered trademark of MagnaChip Semiconductor Ltd.

MagnaChip Semiconductor Ltd.

891, Daechi-Dong, Kangnam-Gu, Seoul, 135-738 Korea

Tel : 82-2-6903-3451 / Fax : 82-2-6903-3668 ~9

www.magnachip.com