

Low Noise, Regulated Charge Pump DC/DC Converter

General Description

Two times charge pump and constant switching frequency configuration with low noise characteristics, low external components makes the EMD3001 unique performance and perfect for the portable applications. Fixed regulated output voltage (EMD3001) is available for different applications with input voltage range from 2.7V to 4.5V and provide up to 100mA of output current.

Soft-start circuitry, preventing the inrush current, thermal shutdown and short circuit protection are all built-in as well. It also features with <1uA low shutdown current when the device is disable.

The EMD3001 is available in a 6-pin SOT-26 package (fixed 5V output).

Features

- Low Noise Constant Frequency Operation (2MHz)
- 100mA Output Current
- Power Range form 2.7V to 4.5V
- Shutdown Current < 1μA
- Needs No Inductors
- Soft Start Function Reduces Inrush Current And Has Slew Rate Control
- Output Voltage Regulates to 5V ± 4% or Adj.
- Uses Small Ceramic Capacitor of 1μF
- Thermal Shutdown Protects Output Over Loading
- Protects Output Shorted to Ground
- PWM dimming Control WLED Brightness
- 5V Fixed Version in SOT-26

Applications

- White LED Driver
- 3V to 5V Charge Pump Conversion
- Battery Backup Supplies
- Handheld Portable Devices

Package & Ordering Information

CONNECTION DIAGRAM

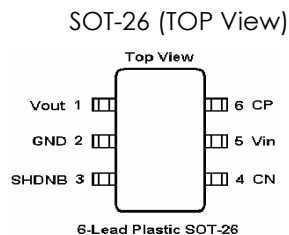
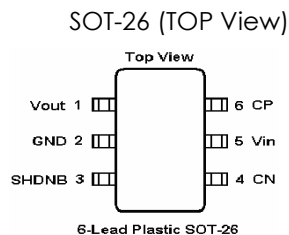

ORDER INFORMATION

EMD3001-50VC06GRR

- 50 Output Fixed voltage
- VC06 SOT-26 Package
- GRR RoHS package
- Rating: -40 to 85°C
- Package in Tape & Reel

EMD3001-50VC06NRR

- 50 Output Fixed voltage
- VC06 SOT-26 Package
- NRR RoHS & Halogen free package
- Rating: -40 to 85°C
- Package in Tape & Reel

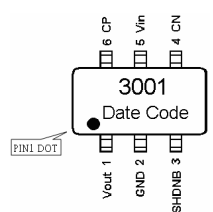
Package Type	Product ID	Package Marking	Transport Media
SOT-26	EMD3001-50VC06GRR		3K units Tape & Reel
	EMD3001-50VC06NRR		

Elite MicroPower Inc. reserves the right to make changes to improve reliability or manufacturability without notice, and customers are advised to obtain the latest version of relevant information prior to placing orders.

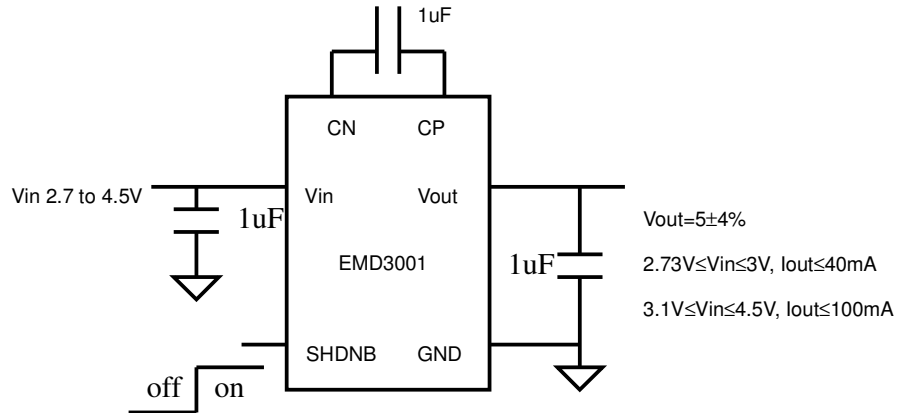
Typical ApplicationsFigure 1. EMD3001 Fixed 5V, V_{IN} from 2.7V to 4.5V

Absolute Maximum Ratings

Output Current -----	150mA	Lead Soldering Temperature (10 sec) -----	300°C
V _{in} , V _{out} , SHDNB Voltage -----	-0.6V to +6V	Recommended Operating Conditions	
V _{out} Short Circuits Duration -----	Indefinite	V _{in} -----	2.7V to 4.5V
ESD Protection (HBM) -----	2KV	C _{in} , C _{out} , C _{fly} -----	1uF
Operating Temperature Range -----	-40°C to +85°C	V _{out} Loading -----	≤100mA
Storage Temperature Range -----	-65°C to +150°C		

Electrical Specifications

Specification are at T_A=25°C, V_{in}=3.6V, C_{fly}=1uF, C_{in}=1uF, C_{out}=1uF unless otherwise noted.

V_{IN}, V_{OUT}, I_Q, V_{IH} and V_{IL} apply over the full operating temperature range.

Symbol	Parameter	Conditions	Min.	Typ.	Max (Specification)	Units	Note
V _{IN}	Input Voltage		2.7		4.5	V	
V _{OUT}	Output Voltage	2.7V ≤ V _{in} ≤ 3.1V, I _{out} ≤ 40mA	4.8	5	5.2	V	
		3.1V < V _{in} ≤ 4.5V, I _{out} ≤ 100mA	4.8	5	5.2	V	
I _Q	Operating Supply Current	I _{out} =0mA, SHDNB=V _{in}		2.5	TBD	mA	
I _{SHDN}	Shutdown Current	SHDN=0V, V _{out} =0V			1	μA	Note1
V _R	Output Ripple	V _{in} =3V, I _{out} =100mA		40		mV _{P-P}	
η	Efficiency	V _{in} =3V, I _{out} =50mA		80		%	
F _{OSC}	Switching Freq.		1	2		MHz	
V _{IH}	SHDN Input Threshold		1.2			V	
V _{IL}	SHDN Input Threshold				0.4	V	
T _{ON}	V _{out} Turn-On Time	V _{in} =3V, I _{out} =0mA, 10% to 90%		0.5		ms	
R _{OL}	Open-Loop Output Resistance	V _{in} =3V, I _{out} =100mA		10		Ω	Note2
I _{SHORT}	Output Short Circuit Current	V _{in} =3.6V, V _{out} =0V	15		55	mA	

Note1: Due to testing limit.

Note2: $R_{OL} \equiv (2V_{in} - V_{out}) / I_{out}$

Elite MicroPower Inc. reserves the right to make changes to improve reliability or manufacturability without notice, and customers are advised to obtain the latest version of relevant information prior to placing orders.

Pin Descriptions

Pin Name	Pin Order EMD3001	Description
CP	6	Positive terminal connection of the fly capacitor.
Vin	5	Input supply voltage.
CN	4	Negative terminal connection of the fly capacitor.
SHDNB	3	High to enable and low to disable the EMD3001.
Vout	1	Output of regulating.
GND	2	Grounding reference of all I/O pin.

Note1: EMD3001 regulates output to 5V and has no feedback pin. Only GND is available.

Typical Performance Characteristics

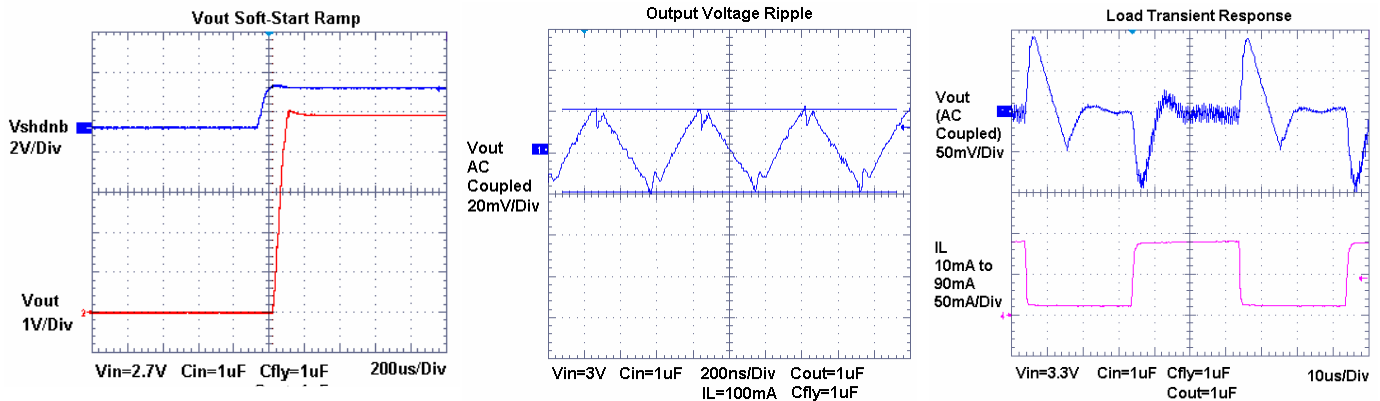

Elite MicroPower Inc. reserves the right to make changes to improve reliability or manufacturability without notice, and customers are advised to obtain the latest version of relevant information prior to placing orders.

Typical Performance Characteristics

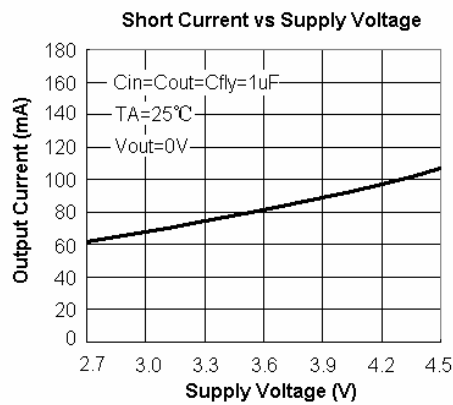
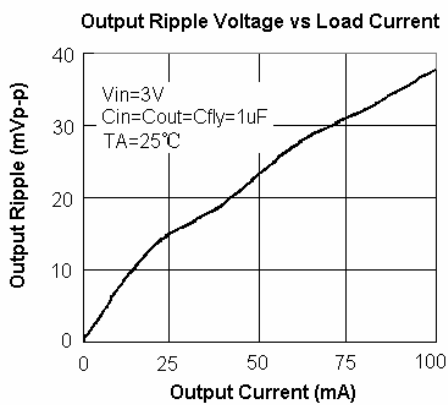
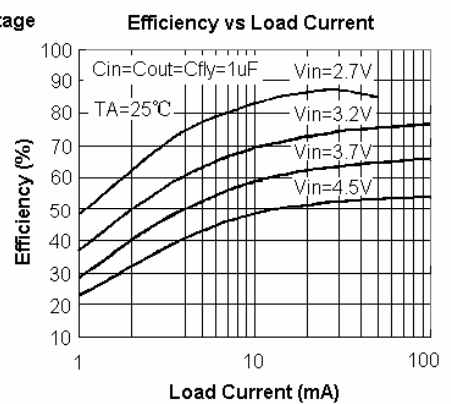
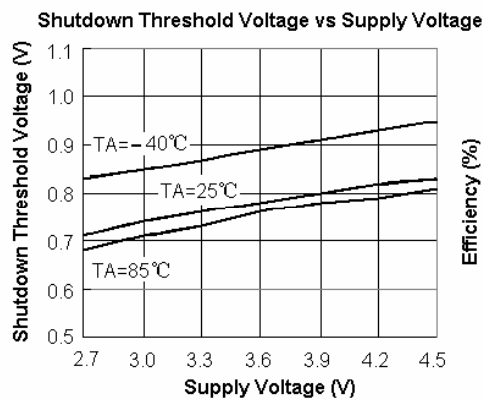
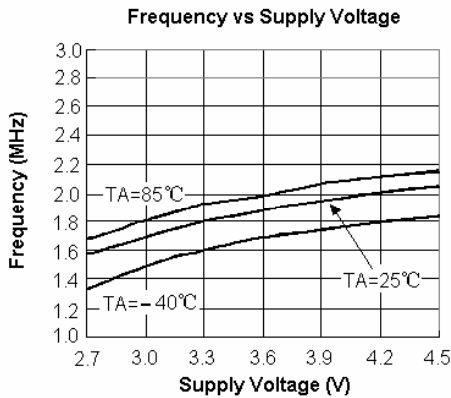
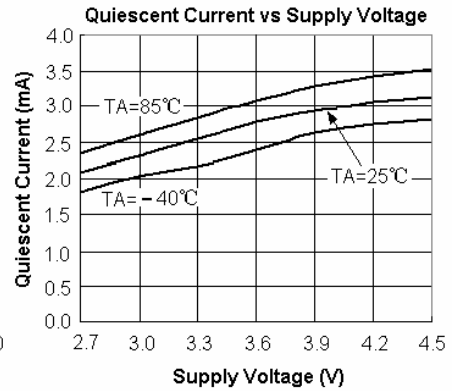
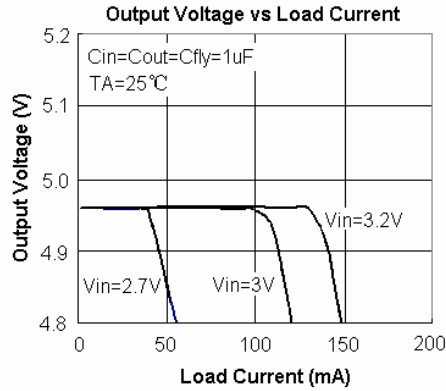
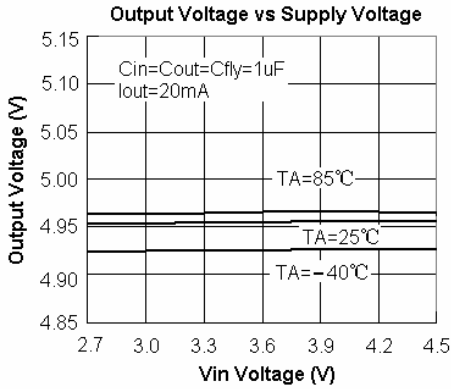

Elite MicroPower Inc. reserves the right to make changes to improve reliability or manufacturability without notice, and customers are advised to obtain the latest version of relevant information prior to placing orders.

Function Block Diagram

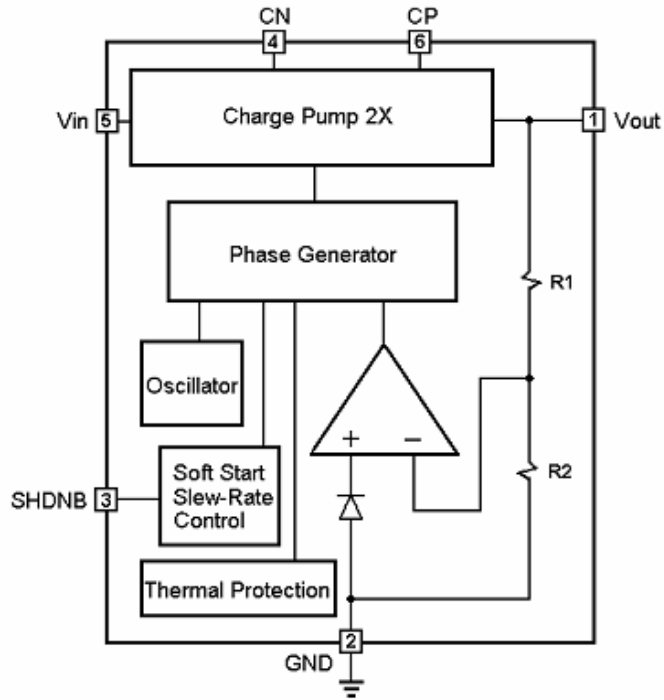

Figure 2. EMD3001 Functional Block Diagram

Operation

Charge-pump operation

The EMD3001 configures a 2X charge-pump and regulates V_{out} to 5V. Sensing the output voltage through internal divided resistors and modulating the charge current by error amplifier's signal are used to regulate the output voltage. The EMD3001 uses a 2MHz-frequency non-overlapping clock phase to pump the fly capacitor then store the charge to the output capacitor and regulate the output voltage cited above.

Shutdown Current

When shutdown is been trigger by low state signal on SHDNB, the output and CP voltage of EMD3001 will pull to ground to guarantee that shutdown current less than $1\mu A$ in very short time.

Soft-Start and Slew-Rate control

The soft-start slew-rate function can reduce the inrush current during the input power ramping time. The start-up time is almost less than 0.5ms in typical condition. During the EMD3001 start-up, the input power will charge a constant current to the fly capacitor and output capacitor.

Short-Circuit and Thermal Protected

To Prevent been damaged by shorting output to ground, the EMD3001 has built-in short-circuit protection to limit the output current up to about 25mA ~ 50mA. And when the loading is getting too large, out of absolute maximum ratings of EMD3001, there is a thermal protected circuitry to prevent too large current flowing through EMD3001 to the output terminal.

Capacitor Selection

C_{fly} , C_{in} and C_{out} capacitors should utilize the low ESR (Equivalent Series Resistance) ceramic capacitor.

The charge pump strength is controlled by the flying capacitor, $1\mu F$ is recommended. For reducing noise and ripple purpose, tantalum and aluminum material capacitors is not recommended. C_{in} and C_{out} should use the low ESR ($<0.1\Omega$) ceramic capacitor for degrade the noise and ripple, $1\mu F$ is recommended. The value of C_{in} , C_{out} , C_{fly} will impact on several important parameters of EMD3001 such as output ripple, start-up time, charge pump strength and loop stability.

Application Circuits

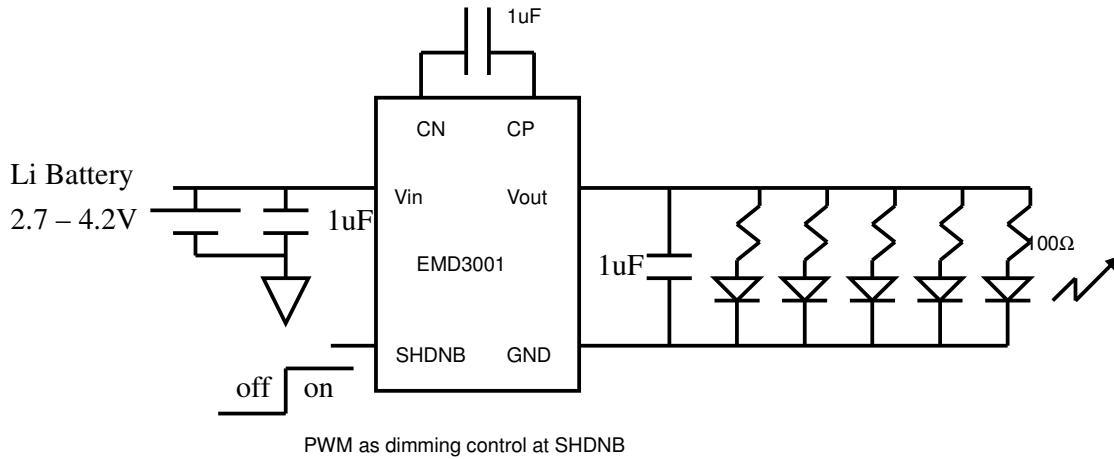

Figure 3. Lithium-Ion Battery to 5V White or Blue LED Driver

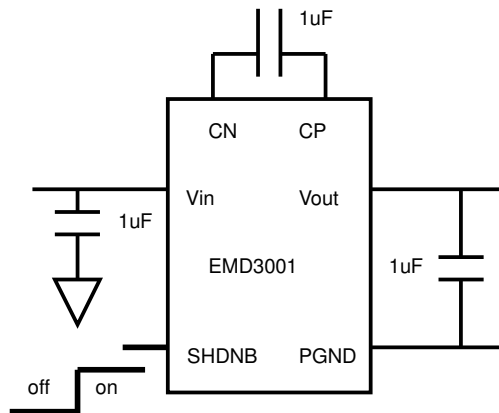
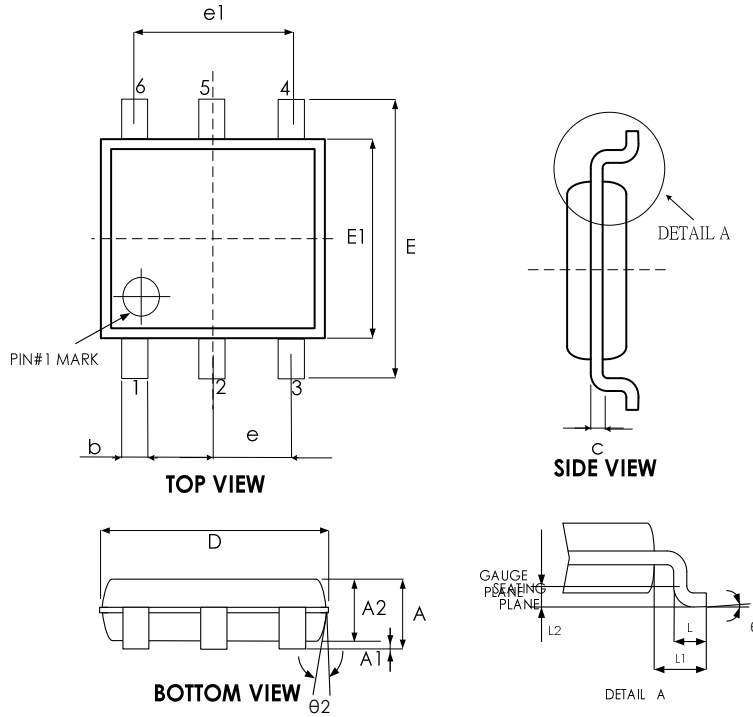

Figure 4. Regulates To 5V System

Elite MicroPower Inc. reserves the right to make changes to improve reliability or manufacturability without notice, and customers are advised to obtain the latest version of relevant information prior to placing orders.

Package Description

SOT-26 Package



SYMBPLS	MIN.	NOM.	MAX.
A	—	—	1.45
A1	—	—	0.15
A2	0.9	1.15	1.3
b	0.3	—	0.5
c	0.08	—	0.22
D	2.90 BSC.		
E	2.80 BSC.		
E1	1.60 BSC.		
e	0.95 BSC		
e1	1.90 BSC		
L	0.3	0.45	0.6
L1	0.60 REF		
L2	0.25 REF		
θ°	0	4	8
$\theta 2^\circ$	5	10	15

UNIT: MM

Elite MicroPower Inc. reserves the right to make changes to improve reliability or manufacturability without notice, and customers are advised to obtain the latest version of relevant information prior to placing orders.

© Copyright 2005 All rights reserved.

No part of this document may be reproduced or duplicated in any form or by any means without the prior permission of EMP.

The contents contained in this document are believed to be accurate at the time of publication. EMP assumes no responsibility for any error in this document, and reserves the right to change the products or specification in this document without notice.

The information contained herein is presented only as a guide or examples for the application of our products. No responsibility is assumed by EMP for any infringement of patents, copyrights, or other intellectual property rights of third parties which may result from its use. No license, either express, implied or otherwise, is granted under any patents, copyrights or other intellectual property rights of EMP or others.

Any semiconductor devices may have inherently a certain rate of failure. To minimize risks associated with customer's application, adequate design and operating safeguards against injury, damage, or loss from such failure, should be provided by the customer when making application designs.

EMP's products are not authorized for use in critical applications such as, but not limited to, life support devices or system, where failure or abnormal operation may directly affect human lives or cause physical injury or property damage. If products described here are to be used for such kinds of application, purchaser must do its own quality assurance testing appropriate to such applications.

Elite MicroPower Inc. reserves the right to make changes to improve reliability or manufacturability without notice, and customers are advised to obtain the latest version of relevant information prior to placing orders.