

Primary Side Power Switcher for Off-line SMPS**AP3968/69/70/70S****General Description**

The AP3968/69/70/70S consists of a primary side regulation controller and a high voltage transistor, and is specially designed for off-line power supplies within 12W output power. Typical applications include adapter for ADSL and auxiliary supplies.

The AP3968/69/70/70S operates at pulse frequency modulation (PFM), and provides accurate constant voltage, constant current (CV/CC) regulation without requiring an opto-coupler and secondary control circuitry. It has internal cable compensation function for tight constant voltage regulation.

The AP3968/69/70/70S solution has fewer component numbers, smaller size, and lower total cost.

The AP3968 is packaged in SOIC-7. The AP3969/70/70S is packaged in DIP-7 and DIP-8.

Features

- Primary Side Control for Eliminating Opto-coupler and Secondary CV/CC Control Circuitry
- Built-in NPN Transistor with $700V_{CBO}$
- Low Start-up Current: $0.2\mu A$ (Typ.)
- Internal Output Cable Voltage Drop Compensation
- Random Frequency Modulation for Low EMI
- Short Circuit Protection
- Low Total Cost Solution
- Output Power Range (Note 1):
AP3968 for 5W Adapter
AP3969 for 7.5W Adapter
AP3970 for 12W Adapter
AP3970S for 10W Adapter

Note 1: Typical continuous power in a non-ventilated enclosed adapter measured at 50°C ambient.

Applications

- Chargers
- Adapters
- Set Top Boxes
- Auxiliary Supplies
- DVD
- LED Driver

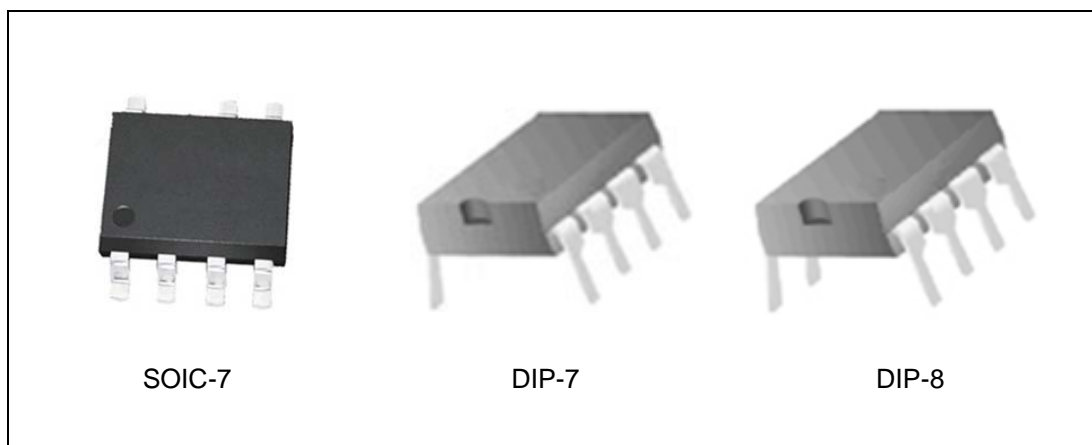

Figure 1. Package Types of AP3968/69/70/70S

Pin Configuration

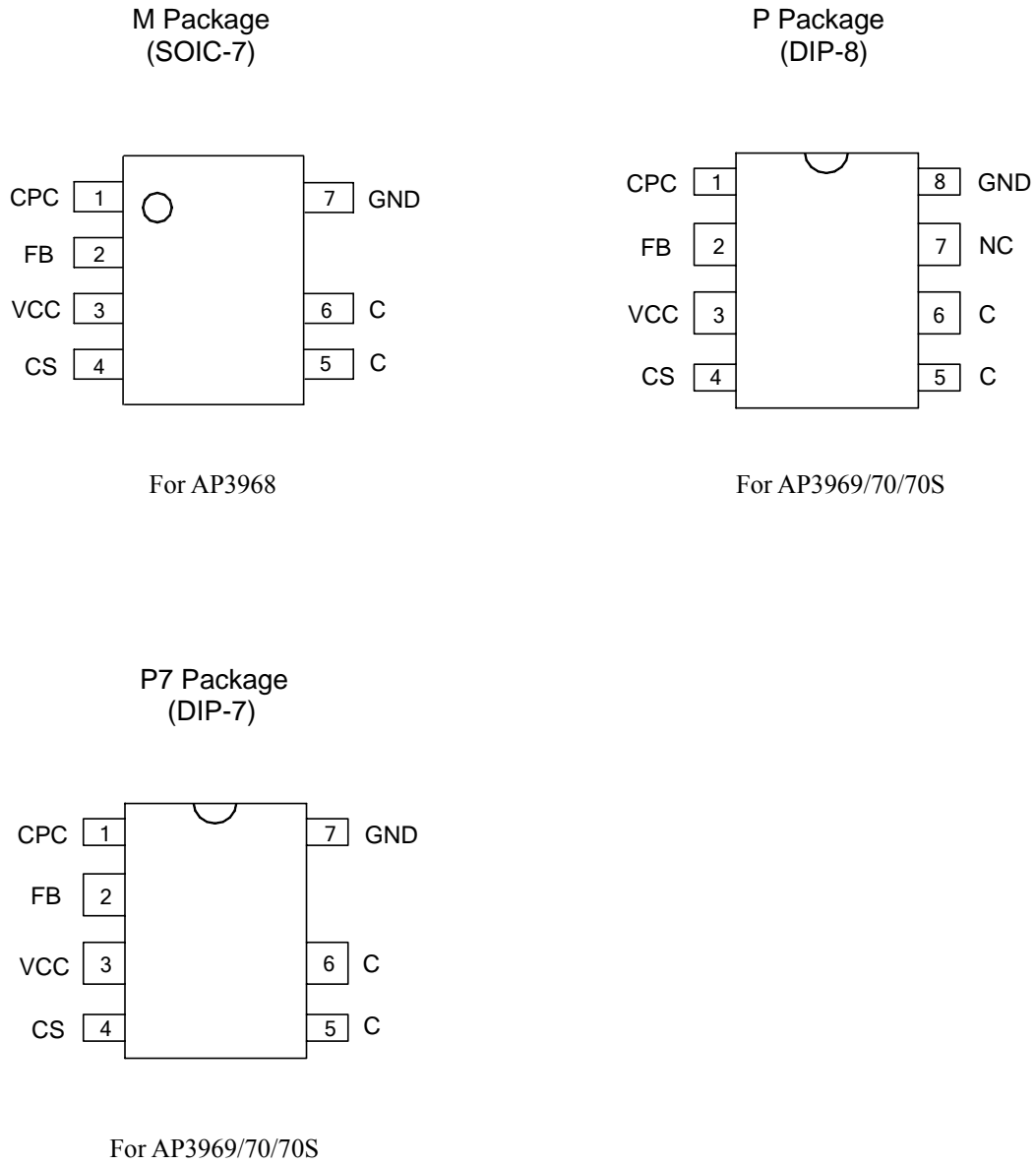

Figure 2. Pin Configuration of AP3968/69/70/70S (Top View)

**Primary Side Power Switcher for Off-line SMPS****AP3968/69/70/70S****Pin Description**

Pin Number		Pin Name	Function
SOIC-7/DIP-7	DIP-8		
1	1	CPC	This pin connects a capacitor to GND for output cable compensation
2	2	FB	The voltage feedback from auxiliary winding
3	3	VCC	This pin receives rectified voltage from the auxiliary winding of the transformer
4	4	CS	Current sense for primary side of transformer
5,6	5,6	C	This pin is connected with an internal power BJT's collector
	7	NC	Not connected
7	8	GND	This pin is the signal reference ground



Primary Side Power Switcher for Off-line SMPS

AP3968/69/70/70S

Ordering Information

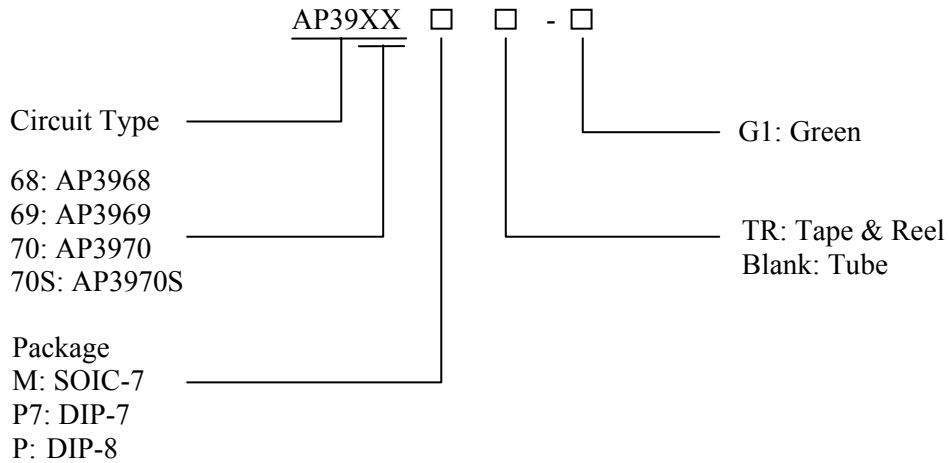

Package	Temperature Range	Part Number	Marking ID	Packing Type
SOIC-7	-40 to 85°C	AP3968M-G1	AP3968M-G1	Tube
		AP3968MTR-G1	AP3968M-G1	Tape & Reel
DIP-7		AP3969P7-G1	AP3969P7-G1	Tube
		AP3970P7-G1	AP3970P7-G1	Tube
		AP3970SP7-G1	AP3970SP7-G1	Tube
DIP-8		AP3969P-G1	AP3969P-G1	Tube
		AP3970P-G1	AP3970P-G1	Tube
		AP3970SP-G1	AP3970SP-G1	Tube

BCD Semiconductor's Pb-free products, as designated with "G1" suffix in the part number, are RoHS compliant and green.

**Primary Side Power Switcher for Off-line SMPS****AP3968/69/70/70S****Absolute Maximum Ratings (Note 2)**

Parameter	Symbol	Value		Unit
Supply Voltage	V_{CC}	-0.3 to 22		V
FB Input Voltage	V_{FB}	-1 to 10		V
Collector-emitter Voltage	V_{CBO}	700		V
Collector DC Current		AP3968/69	1.5	A
		AP3970	4	
		AP3970S	3.2	
Operating Junction Temperature	T_J	150		°C
Storage Temperature	T_{STG}	-65 to 150		°C
Lead Temperature (Soldering, 10 sec)	T_{LEAD}	300		°C
ESD (Machine Model)		200		V
ESD (Human Body Model)		2000		V

Note 2: Stresses greater than those listed under “Absolute Maximum Ratings” may cause permanent damage to the device. These are stress ratings only, and functional operation of the device at these or any other conditions beyond those indicated under “Recommended Operating Conditions” is not implied. Exposure to “Absolute Maximum Ratings” for extended periods may affect device reliability.

Recommended Operating Conditions

Parameter	Symbol	Min	Max	Unit
Supply Voltage	V_{CC}		22	V
Operating Temperature Range	T_{OP}	-40	85	°C
Maximum Operating Frequency	f_{MAX}		60	kHz



Primary Side Power Switcher for Off-line SMPS

AP3968/69/70/70S

Electrical Characteristics

V_{CC}=15V, T_J=25°C, unless otherwise specified.

Parameter	Symbol	Conditions	Min	Typ	Max	Unit
UVLO Section						
Turn-on Voltage	V _{ON}		13	15	17	V
Turn-off Voltage	V _{OFF}	No drive Current	4.5	5.3	6.3	V
Standby Current Section						
Start-up Current	I _{ST}	V _{CC} =V _{ON} -0.5V		0.2	0.6	μA
Operating Current	I _{CC}		320	435	550	
Feedback Input Section						
FB Input Current	I _{FB}	V _{FB} =4V	1.5	3.5	5.5	μA
FB Threshold Voltage	V _{FB}		4.23	4.3	4.37	V
Power Transistor Section						
Collector-emitter Saturation Voltage	V _{CE(SAT)}	AP3968/9: I _C =0.5A AP3970/70S: I _C =1A			0.3	V
DC Current Gain	h _{FE}	AP3968/69	14	17		
		AP3970/70S	17	26		
Leakage Current	I _{CEO}				60	nA
Over Temperature Protection						
Shutdown Temperature	T _{SHDN}	Surface temperature	125	160		°C
Temperature Hysteresis				40		°C

Thermal Impedance

Parameter	Symbol	Value		Unit
Junction to Ambient	θ _{JA}	AP3968	80	°C/W
		AP3969	60	
		AP3970	45	
		AP3970S	50	
Junction to Case	θ _{JC}	AP3968	40	
		AP3969	30	
		AP3970	22	
		AP3970S	26	



Typical Performance Characteristics

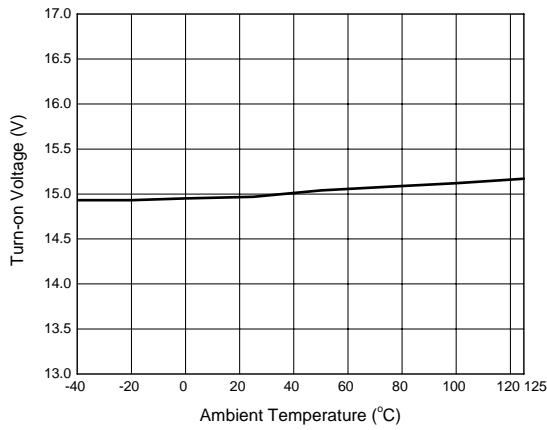

Figure 4. Turn-on Voltage vs. Ambient Temperature

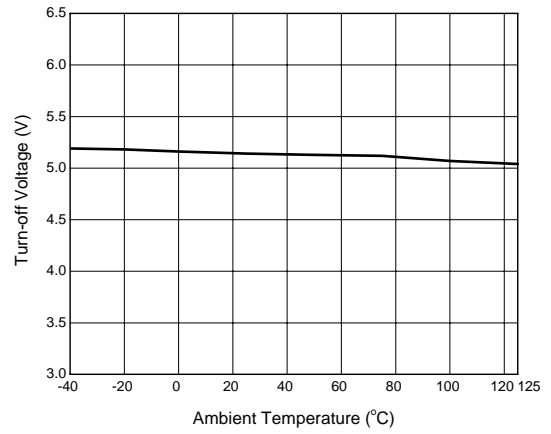

Figure 5. Turn-off Voltage vs. Ambient Temperature

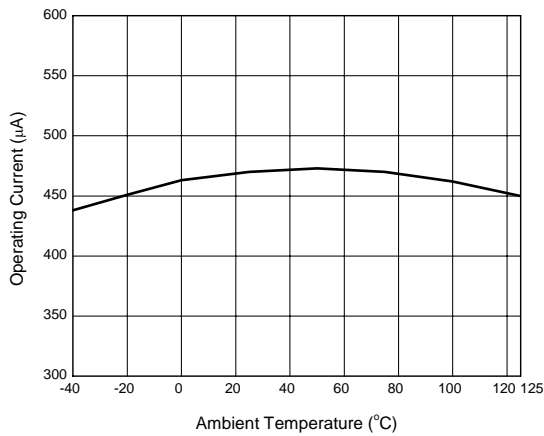

Figure 6. Operating Current vs. Ambient Temperature

Operation Description

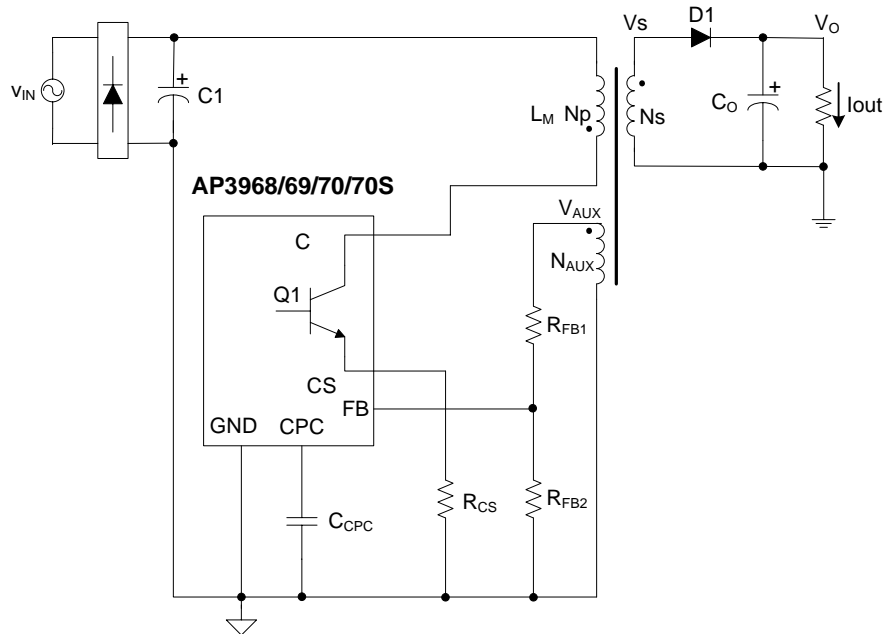

Figure 7. Simplified Flyback Converter Controlled by AP3968/69/70/70S

Figure 7 illustrates a simplified flyback converter controlled by AP3968/69/70/70S.

$$I_{pk} = \frac{V_{cs}}{R_{cs}} \dots\dots\dots(2)$$

Constant Primary Peak Current

The primary current $I_p(t)$ is sensed by a current sense resistor R_{CS} as shown in Figure 7.

The energy stored in the magnetizing inductance L_M each cycle is therefore:

The current rises up linearly at a rate of:

$$E_g = \frac{1}{2} \cdot L_M \cdot I_{pk}^2 \dots\dots\dots(3)$$

$$\frac{di_p(t)}{dt} = \frac{vg(t)}{L_M} \dots\dots\dots(1)$$

So the power transferring from input to output is given by:

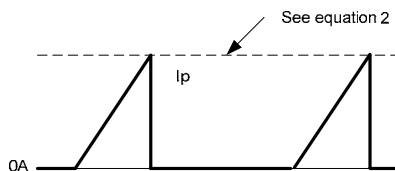

$$P = \frac{1}{2} \cdot L_M \cdot I_{pk}^2 \cdot f_{sw} \dots\dots\dots(4)$$

Figure 8. Primary Current Waveform

Where f_{sw} is the switching frequency. When the peak current I_{pk} is constant, the output power depends on the switching frequency f_{sw} .

As illustrated in Figure 8, when the current $I_p(t)$ rises up to I_{pk} , the switch Q1 turns off. The constant peak current is given by:

Constant Voltage Operation

The AP3968/69/70/70S captures the auxiliary winding feedback voltage at FB pin and operates in constant-voltage (CV) mode to regulate the output

Primary Side Power Switcher for Off-line SMPS

AP3968/69/70/70S

voltage. Assuming the secondary winding is master, the auxiliary winding is slave during the D1 on-time. The auxiliary voltage is given by:

$$V_{AUX} = \frac{N_{AUX}}{N_S} \cdot (V_O + V_d) \dots\dots\dots(5)$$

Where V_d is the diode forward drop voltage, N_{AUX} is the turns of auxiliary winding, and N_S is the turns of secondary winding.

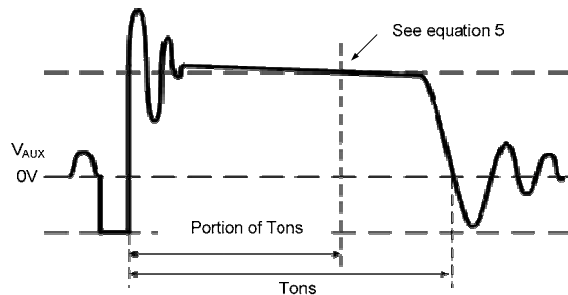

Figure 9. Auxiliary Voltage Waveform

The output voltage is different from the secondary voltage in a diode forward drop voltage V_d which depends on the current. If the secondary voltage is always detected at a constant secondary current, the difference between the output voltage and the secondary voltage will be a fixed V_d . The voltage detection point is portion of T_{ons} after D1 is turned on. The CV loop control function of AP3968/69/70/70S then generates a D1 off-time to regulate the output voltage.

Constant Current Operation

The AP3968/69/70/70S is designed to work in constant current (CC) mode. Figure 10 shows the secondary current waveforms.

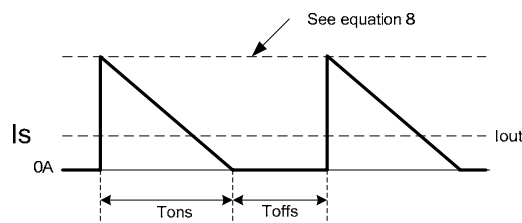

Figure 10. Secondary Current Waveform

In CC operation, the CC loop control function of AP3968/69/70/70S will keep a fixed proportion between D1 on-time T_{ons} and D1 off-time T_{offs} by

discharging or charging the built-in capacitance connected. This fixed proportion is

$$\frac{T_{ons}}{T_{offs}} = \frac{4}{3} \dots\dots\dots(6)$$

The relation between the output constant-current and secondary peak current I_{pks} is given by:

$$I_{out} = \frac{1}{2} \cdot I_{pks} \cdot \frac{T_{ons}}{T_{ons} + T_{offs}} \dots\dots\dots(7)$$

At the instant of D1 turn-on, the primary current transfers to the secondary at an amplitude of:

$$I_{pks} = \frac{N_P}{N_S} \cdot I_{pk} \dots\dots\dots(8)$$

Thus the output constant current is given by:

$$I_{out} = \frac{2}{7} \cdot \frac{N_P}{N_S} \cdot I_{pk} \dots\dots\dots(9)$$

Leading Edge Blanking (LEB)

When the power switch is turned on, a turn-on spike on the output pulse rising edge will occur on the sense-resistor. To avoid false termination of the switching pulse, a typical 500ns leading edge blanking is built in. During this blanking period, the current sense comparator is disabled and the gate driver can not be switched off.

The built-in LEB in AP3968/69/70/70S has shorter delay time from current sense terminal to output pulse than those IC solutions adopting external RC filter as LEB.

Built-in Cable Compensation

The AP3968/69/70/70S has built-in fixed voltage of 0.35V typical to compensate the drop of output cable when the load is changed from zero to full load. A typical 0.01 μ F external capacitor connected to the CPC pin is used to smooth voltage signal for cable compensation.

Over Temperature Protection

The AP3968/69/70/70S has internal thermal sensing circuit to shut down the PFM driver output when the die temperature reaches 160 $^{\circ}$ C typical. When the die temperature drops about 40 $^{\circ}$ C, the IC will recover automatically to normal operation.

Typical Application

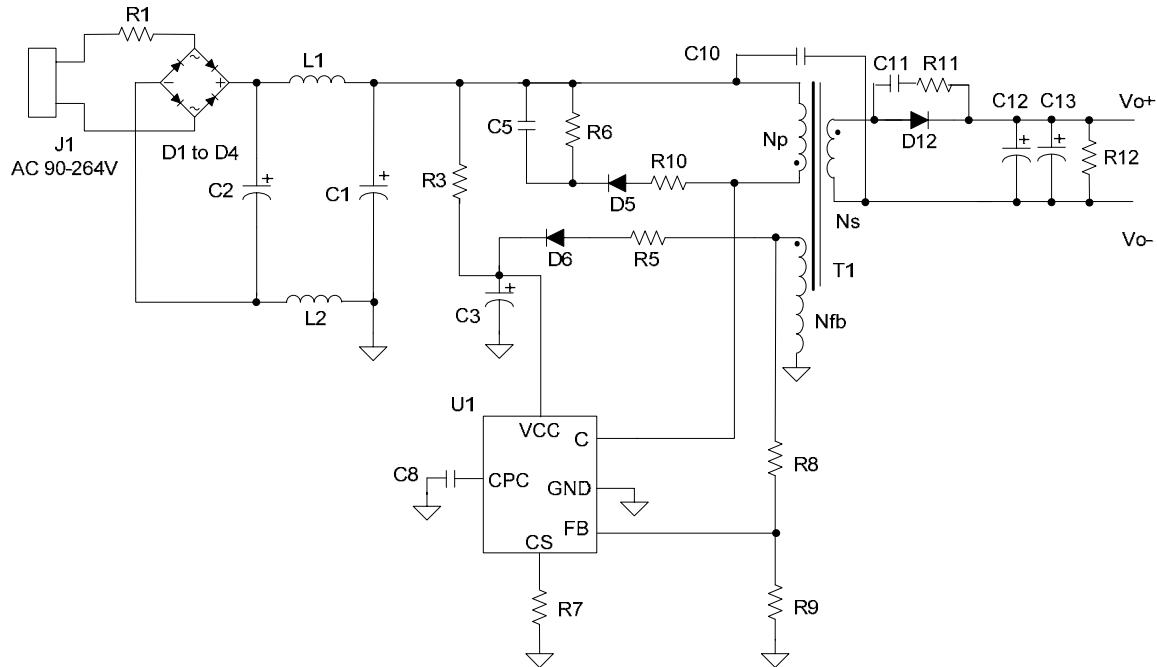

Figure 11. Typical Application of AP3969 (9V/800mA)

Item	Description	QTY	Item	Description	QTY
C1	10.0 μ F/400V, electrolytic	1	U1	AP3969	1
C2	4.7 μ F/400V, electrolytic	1	R1	11 Ω , 2W	1
C3	3.3 μ F/50V, electrolytic	1	R3	3.3M Ω /0.25W	1
C5	1nF/1kV, ceramic	1	R5	3.9 Ω , 0805	1
C8	0.01 μ F, 0805	1	R6	150K Ω , 1206	1
C10	1nF/250Vac, Y1 capacitor	1	R7	1 Ω , 1206	1
C11	1nF, 0805	1	R8	20K Ω , 0805	1
C12, C13	470 μ F/16V	2	R9	13K Ω , 0805	1
D1 to D6	1N4007, rectifier diode	6	R10	360 Ω , 0805	1
D12	SB3100	1	R11	27 Ω , 0805	1
L1	470 μ H, inductor	1	R12	1.2k Ω , 0805	1
L2	Bead, 0805	1	T1	EE16 core, PC40, transformer	1

Mechanical Dimensions

SOIC-7

Unit: mm(inch)

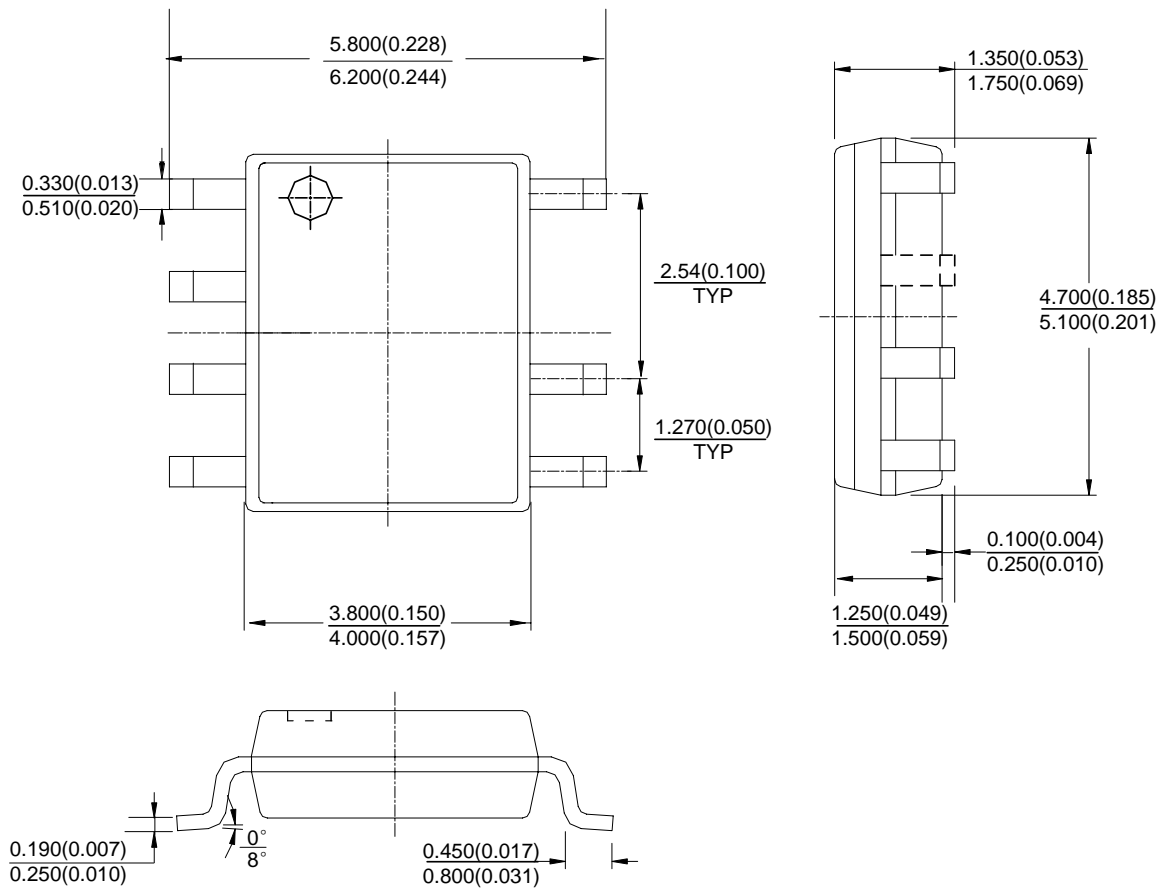

Note: Eject hole, oriented hole and mold mark is optional.

Mechanical Dimensions (Continued)

DIP-7

Unit: mm(inch)

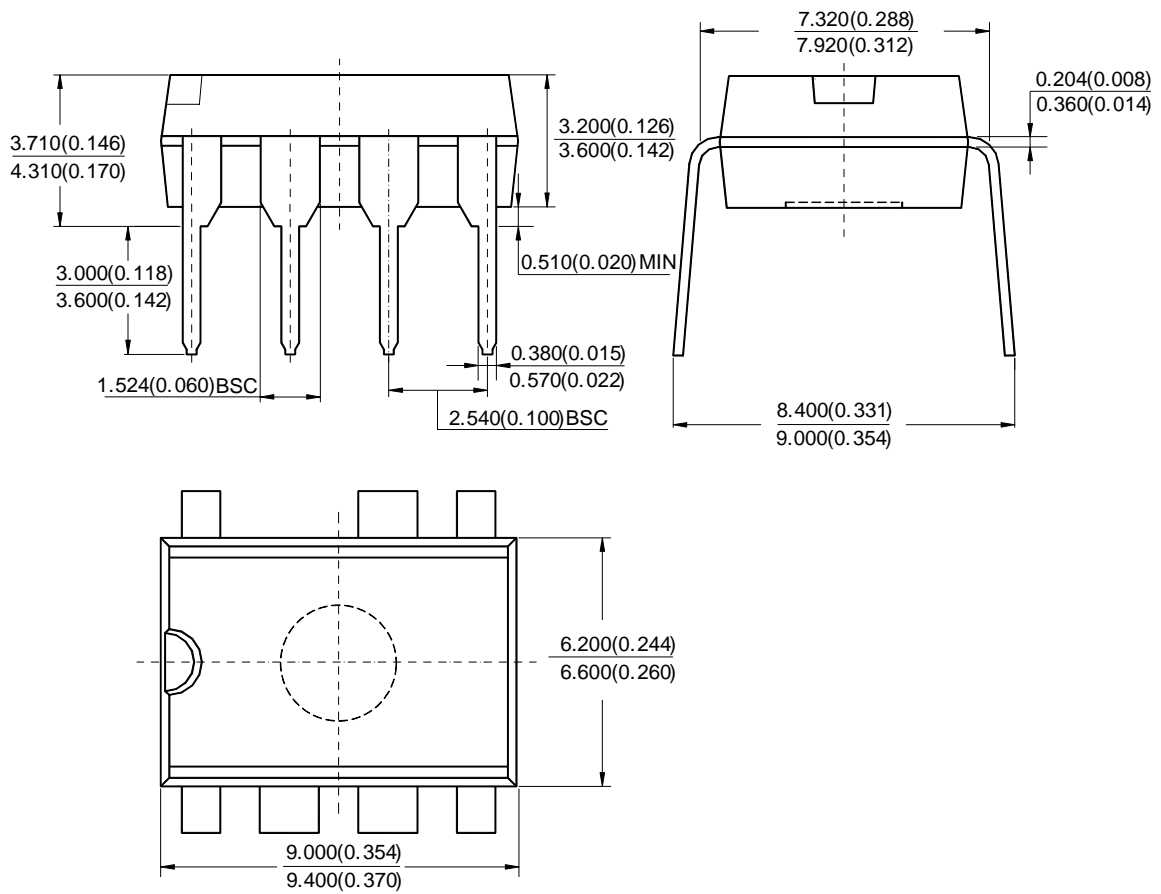

Note: Eject hole, oriented hole and mold mark is optional

Mechanical Dimensions (Continued)

DIP-8

Unit: mm(inch)

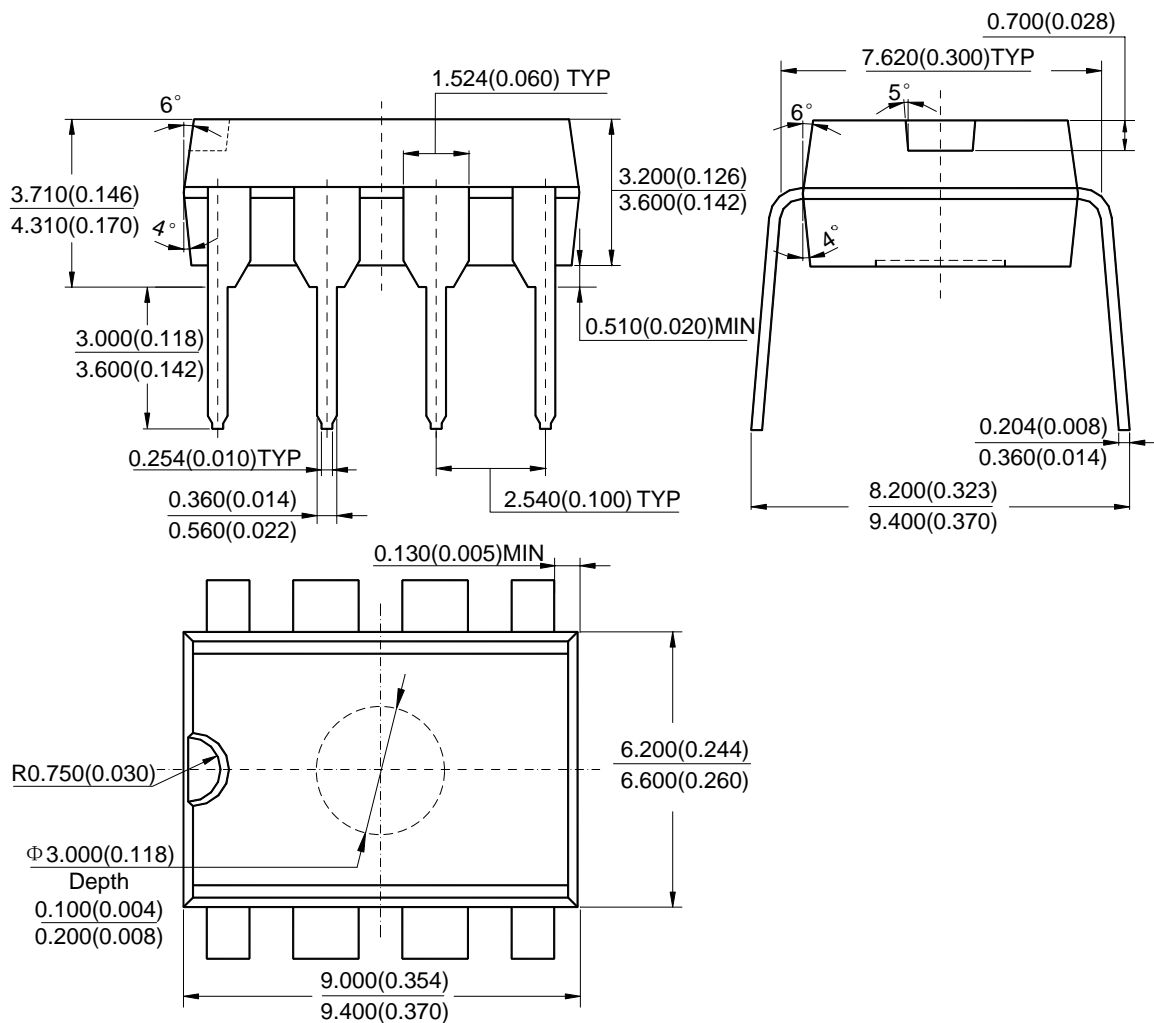

Note: Eject hole, oriented hole and mold mark is optional.

