

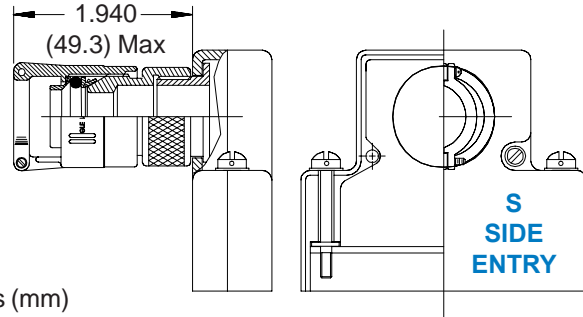

550-002 Environment Resisting EMI/RFI D-Subminiature Strain-Relief Split Backshell for Overall Shielding

550 T 002 M 2 F0 B 1 L
 Basic Part No. _____
 Cable Entry Style _____
 T = Top
 S = Side
 E = End
 Basic Part Number _____
 Finish Symbol (Page 3) _____
 Shell Size (Table I) _____

L = Strain Relief, G = Gland Nut
 0 = Without EMI Gasket
 1 = With EMI Gasket
 Jackscrew Type (Page A-4)
 Receptacle Mounting (Right Page)
 CC = Cable-to-Cable Mounting
 F0 = Front Mounting
 R1-R9 = Rear Mounting

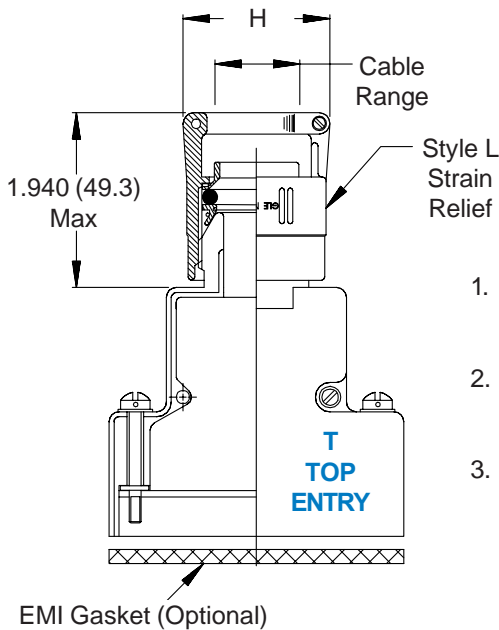

1. Metric dimensions (mm) are indicated in parentheses.
2. **DO NOT USE CONNECTORS WITH FLOAT MOUNTINGS.**
3. Overall shield. Thickness range: 0 to .062 (1.6)

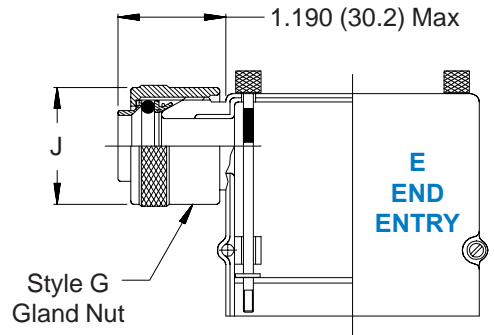

TABLE I: CABLE ENTRY & ENTRY STYLE

Shell Size	Com'l Shell Size Ref	H Max	J Max	Entry Styles S & T Cable Range				Entry Style E Cable Range	
				Min		Max		Min	Max
1	E/09	1.046 (26.6)	.843 (21.4)	.125 (3.2)	.250 (6.4)	.250 (6.4)	.375 (9.5)	.250 (6.4)	.375 (9.5)
2	A/15	1.046 (26.6)	.843 (21.4)	.250 (6.4)	.375 (9.5)	.250 (6.4)	.375 (9.5)	.250 (6.4)	.375 (9.5)
3	B/25	1.156 (29.4)	.968 (24.6)	.312 (7.9)	.475 (12.1)	.312 (7.9)	.475 (12.1)	.312 (7.9)	.475 (12.1)
4	C/37	1.156 (29.4)	.968 (24.6)	.312 (7.9)	.475 (12.1)	.312 (7.9)	.475 (12.1)	.312 (7.9)	.475 (12.1)
5	D/50	1.218 (30.9)	1.109 (28.2)	.437 (11.1)	.575 (14.6)	.437 (11.1)	.575 (14.6)	.437 (11.1)	.575 (14.6)
6*	F/104	1.594 (40.5)	1.468 (37.3)	.812 (20.6)	1.000 (25.4)	n/a	n/a	n/a	n/a

* Shell Size 6 Available in Top Entry Only.

D-Subminiature Split Backshells Standard Dimensions



MIL-C-24308
D-Subminiature

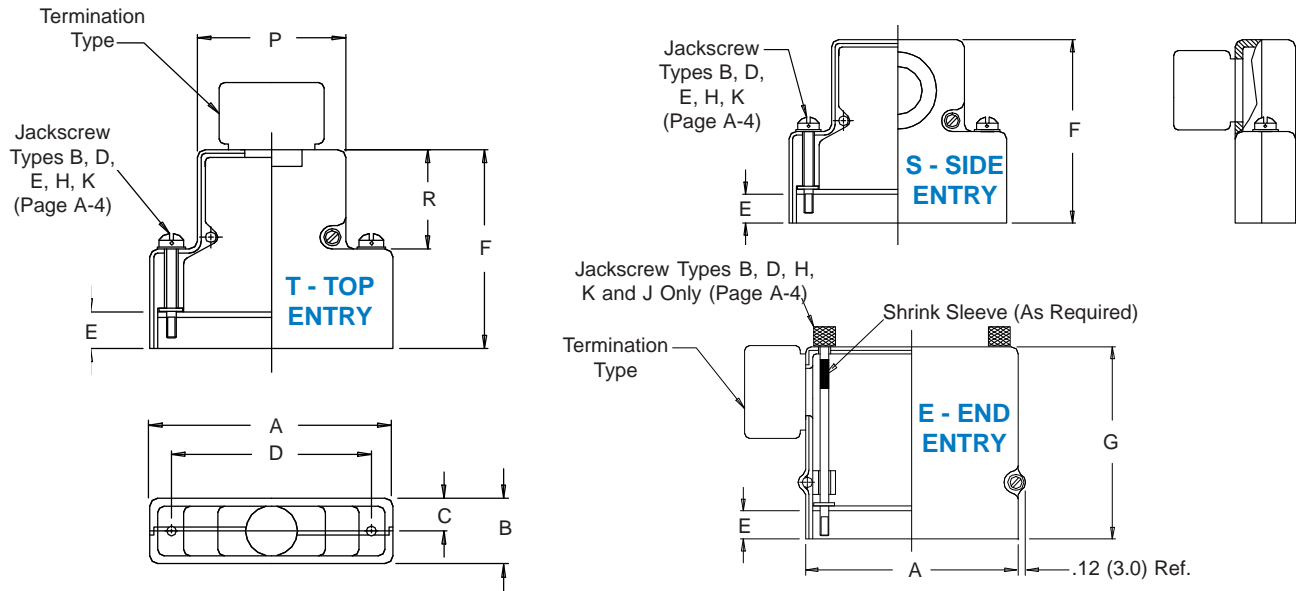

COMMON CONNECTOR/SHELL INTERFACE & BACKSHELL DIMENSIONS

Shell Size	Com'l Shell Size Ref	A Max	B Max	C Ref.	D ±.005 (.1)	P	R Ref
1	E/09	1.393 (35.4)	.624 (15.8)	.312 (7.9)	.984 (25.0)	.730 (18.5)	.719 (18.3)
2	A/15	1.706 (43.3)	.624 (15.8)	.312 (7.9)	1.312 (33.3)	1.050 (26.7)	.719 (18.3)
3	B/25	2.265 (57.5)	.624 (15.8)	.312 (7.9)	1.852 (47.0)	1.594 (40.5)	.938 (23.8)
4	C/37	2.900 (73.7)	.624 (15.8)	.312 (7.9)	2.500 (63.5)	2.240 (56.9)	.938 (23.8)
5	D/50	2.800 (71.1)	.750 (19.1)	.375 (9.5)	2.406 (61.1)	2.140 (54.4)	.938 (23.8)
6	F/104	2.900 (73.7)	.844 (21.4)	.422 (10.7)	2.500 (63.5)	2.240 (56.9)	1.094 (27.8)

CABLE MOUNTING AND BACKSHELL DIMENSIONS

Dash No.	Panel Thickness	E	F ± .031 (0.79)			G ± .031 (0.79)	
			Sizes 1 & 2	Sizes 3 - 5	Size 6	Sizes 1 & 2	Sizes 3 - 5
CC	n/a	.174 (4.4)	1.451 (36.9)	1.671 (42.4)	1.820 (46.2)	1.583 (40.2)	1.831 (46.5)
F0	n/a	.343 (8.7)	1.625 (41.3)	1.844 (46.8)	2.000 (50.8)	1.750 (44.5)	2.000 (50.8)
R1	.031 (.8)	.247 (6.3)	1.525 (38.7)	1.745 (44.3)	1.890 (48.0)	1.656 (42.1)	1.904 (48.4)
R2	.047 (1.2)	.231 (5.9)	1.509 (38.3)	1.728 (43.9)	1.875 (47.6)	1.640 (41.7)	1.888 (48.0)
R3	.062 (1.6)	.216 (5.5)	1.500 (38.1)	1.720 (43.7)	1.860 (47.2)	1.625 (41.3)	1.873 (47.6)
R4	.093 (2.4)	.185 (4.7)	1.470 (37.3)	1.690 (42.9)	1.829 (46.5)	1.594 (40.5)	1.842 (46.8)
R5	.104 (2.6)	.174 (4.4)	1.451 (36.9)	1.671 (42.4)	1.820 (46.2)	1.583 (40.2)	1.831 (46.5)
R6	.125 (3.2)	.153 (3.9)	1.430 (36.3)	1.650 (41.9)	1.798 (45.7)	1.563 (39.7)	1.811 (46.0)
R7	.156 (4.0)	.125 (3.2)	1.400 (35.6)	1.620 (41.1)	1.767 (44.9)	1.531 (38.9)	1.781 (45.2)
R8	.135 (3.4)	.140 (3.6)	1.417 (36.0)	1.637 (41.6)	1.805 (45.8)	1.550 (39.4)	1.798 (45.7)
R9	.188 (4.8)	.094 (2.4)	1.368 (34.7)	1.590 (40.4)	1.740 (44.2)	1.500 (38.1)	1.750 (44.5)

1. Metric dimensions (mm) are indicated in parentheses.