

1A, 0.5V Low Input Voltage, High Speed LDO Regulator

■ GENERAL DESCRIPTION

The XC6602 series is a low voltage input (0.5V) operation and provides high accuracy $\pm 15\text{mV}/\pm 20\text{mV}$ and can supply large current efficiently due to its ultra low on-resistance even at low output voltages.

The series is ideally suited to the applications which require high current in low input/output voltages and consists of a Nch driver transistor, a voltage reference, an error amplifier, a current limiter, a fold-back circuit, a thermal shutdown (TSD) circuit, an under voltage lock out (UVLO) circuit, a soft-start circuit and a phase compensation circuit.

Output voltage is selectable in 0.1V increments within a range of 0.5V to 1.8V using laser trimming technology and ceramic capacitors can be used for the output stabilization capacitor (C_L). The inrush current (I_{RUSH}) from V_{IN} to V_{OUT} for charging C_L at start-up can be reduced and makes the V_{IN} stable. The soft-start time is optimized internally.

The CE function enables the output to be turned off and the series to be put in stand-by mode resulting in greatly reduced power consumption. At the time of entering the stand-by mode, the series enables the electric charge at the output capacitor (C_L) to be discharged via the internal switch. As a result the V_{OUT} pin quickly returns to the V_{SS} level.

The CE pull-down function keeps the IC to be in stand-by mode even if the CE pin is left open.

■ APPLICATIONS

- Smart phones / Mobile phones
- Digital still cameras / Camcorders
- Note PC / Tablet PC
- E-book Readers / Electronic dictionaries
- Wireless LAN

■ FEATURES

Maximum Output Current	: 1A (1.3A Limit)
ON Resistance	: $0.15\Omega @ V_{\text{BIAS}}=3.6\text{V}, V_{\text{OUT}}=1.2\text{V}$
Bias Voltage Range	: 2.5V~6.0V
Input Voltage Range	: 0.5V~3.0V
Output Voltage Range	: 0.5V~1.8V (0.1V increments)
Output Voltage Accuracy	: $\pm 0.015\text{V} @ V_{\text{OUT}} < 1.2\text{V}$ $\pm 0.020 @ V_{\text{OUT}} \geq 1.2\text{V}$
Ripple Rejection	: 60dB @ $f=1\text{kHz}$ ($V_{\text{BIAS_PSRR}}$) 75dB @ $f=1\text{kHz}$ ($V_{\text{IN_PSRR}}$)
Low Power Consumption	: $100\mu\text{A}$ (V_{BIAS}), $6.5\mu\text{A}$ (V_{IN}) @ $V_{\text{OUT}}=1.2\text{V}$
Stand-by Current	: $0.01\mu\text{A}$ (V_{BIAS}), $0.01\mu\text{A}$ (V_{IN})
Under-voltage Lockout	: 1.8V (V_{BIAS}), 0.4V (V_{IN})
Thermal Shutdown	: 150°C @ detect, 125°C @ release
Protection Circuit	: Fold-back Current Limit, TSD, UVLO
Function	: Built-in Soft-start CE Pull-Down (Active High) C_L Auto Discharge
Operating Ambient Temperature	: $-40^\circ\text{C} \sim +85^\circ\text{C}$
Output Capacitor	: Ceramic Capacitor Compatible ($2.2\mu\text{F}$)
Packages	: USP-6C, SOT-26W, SOT-89-5, WLP-5-02
Environmentally Friendly	: EU RoHS Compliant, Pb Free

■ TYPICAL APPLICATION CIRCUIT

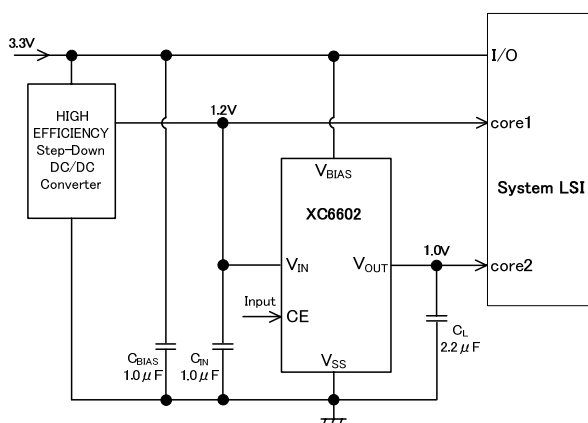

■ TYPICAL PERFORMANCE CHARACTERISTICS

● Dropout Voltage vs. Output Current

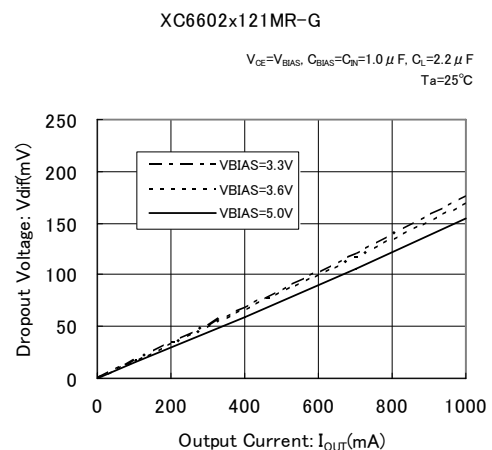

PIN CONFIGURATION

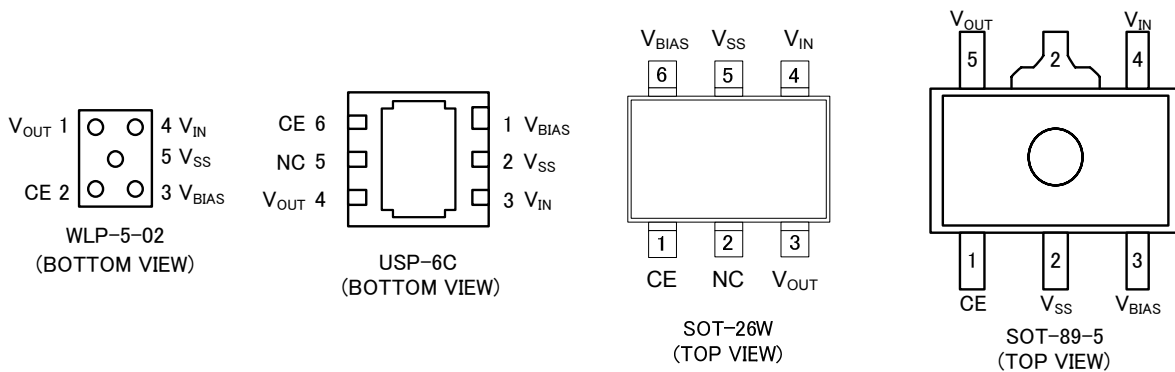

*The dissipation pad for the USP-6C package should be solder-plated in recommended mount pattern and metal masking so as to enhance mounting strength and heat release. If the pad needs to be connected to other pins, it should be connected to the V_{SS} (No. 2) pin.

PIN ASSIGNMENT

PIN NUMBER				PIN NAME	FUNCTIONS
USP-6C	SOT-26W	SOT-89-5	WLP-5-02		
1	6	3	3	V _{BIAS}	Power Supply Input
2	5	2	5	V _{SS}	Ground
3	4	4	4	V _{IN}	Driver Transistor Input
4	3	5	1	V _{OUT}	Output
5	2	-	-	NC	No Connection
6	1	1	2	CE	ON/OFF Control

FUNCTION CHART

XC6602 Series, Type A/B

PIN NAME	SIGNAL	STATUS
CE	L	Stand-by
	H	Active
	OPEN	Stand-by

PRODUCT CLASSIFICATION

Ordering Information

XC6602①②③④⑤⑥-⑦^(*) With soft-start circuit built-in, can be selected from with or without functions

DESIGNATOR	ITEM	SYMBOL	DESCRIPTION
①	Type	A	Soft-start included
		B	Soft-start excluded
②③	Output Voltage	05~18	e.g. 1.2V → ②=1, ③=2
④	Output Voltage Accuracy	1	±0.015V (V _{OUT} < 1.2V), ±0.020V (V _{OUT} ≥ 1.2V)
⑤⑥-⑦ ^(*)	Packages (Order Unit)	ER-G	USP-6C (3,000/Reel)
		MR-G	SOT-26W (3,000/Reel)
		PR-G	SOT-89-5 (1,000/Reel)
		0R-G	WLP-5-02 (3,000/Reel)

^(*) The "-G" suffix denotes Halogen and Antimony free as well as being fully EU RoHS compliant.

■ BLOCK DIAGRAMS

• Type A

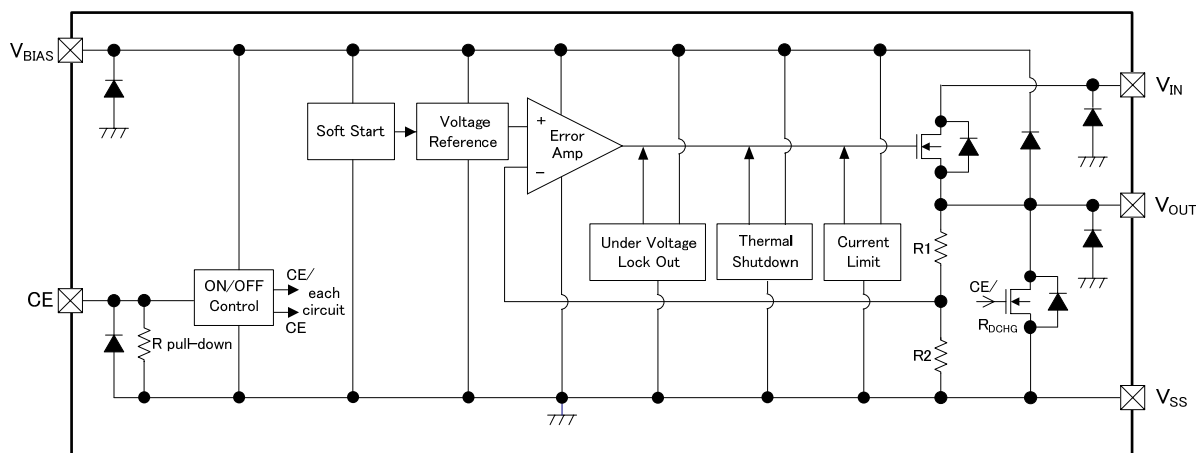

• Type B

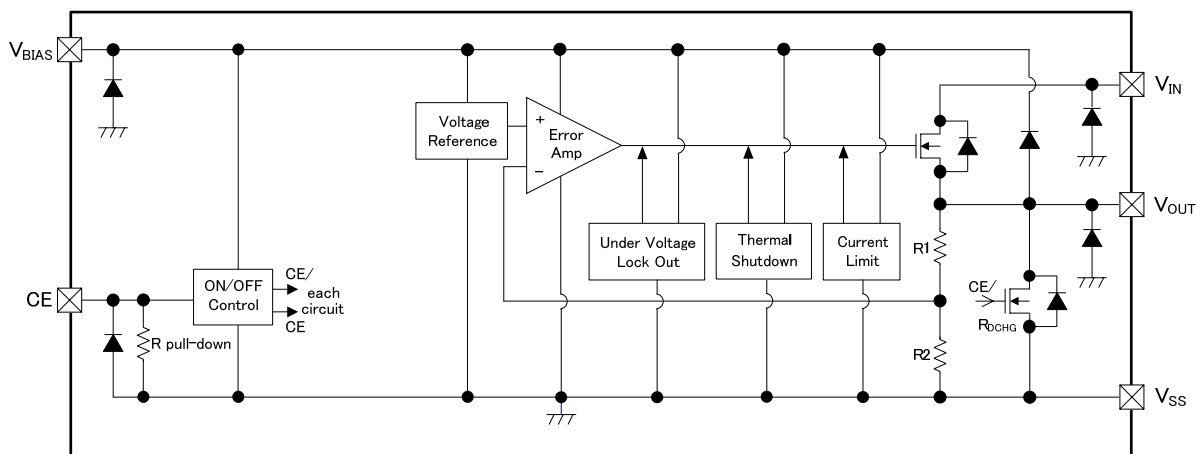

* Diodes inside the circuits are ESD protection diodes and parasitic diodes.

■ ABSOLUTE MAXIMUM RATINGS

Ta=25°C

PARAMETER	SYMBOL	RATINGS	UNITS
Bias Voltage	V _{BIAS}	V _{SS} -0.3~V _{SS} +6.5	V
Input Voltage	V _{IN}	V _{SS} -0.3~V _{SS} +6.5	V
Output Current	I _{OUT}	1.65 ^(*)	A
Output Voltage	V _{OUT}	V _{SS} -0.3~V _{BIAS} +0.3 ≤ V _{SS} +6.5	V
		V _{SS} -0.3~V _{IN} +0.3 ≤ V _{SS} +6.5	V
CE Input Voltage	V _{CE}	V _{SS} -0.3~V _{SS} +6.5	V
Power Dissipation	Pd	120	mW
		1000 (PCB mounted) ^(*)	
		250	
		600 (PCB mounted) ^(*)	
		500	
Operating Ambient Temperature	Topr	-40~+85	°C
		Storage Temperature	Tstg

(*)1) I_{OUT} ≤ Pd / (V_{IN} - V_{OUT})

(*)2) The power dissipation measured with the test board condition is listed as reference data. Please refer to page 25~28 for details.

ELECTRICAL CHARACTERISTICS

Ta=25°C

PARAMETER	SYMBOL	CONDITIONS	MIN	TYP	MAX	UNITS	CIRCUIT	
Bias Voltage	V _{BIAS}		2.5	-	6.0	V	①	
Input Voltage	V _{IN}		0.5	-	3.0	V	①	
Output Voltage	V _{OUT(E)} ⁽²⁾	I _{OUT} =100mA V _{OUT(T)} < 1.2V V _{OUT(T)} ≥ 1.2V	-0.015 -0.020	-	+0.015 +0.020	V	①	
Maximum Output Current ⁽⁴⁾	I _{OUTMAX}	V _{OUT(T)} ≤ 1.2V, V _{BIAS} =V _{CE} =2.5V V _{OUT(T)} > 1.2V, V _{BIAS} =V _{CE} =V _{OUT(T)} +1.3V	1.0	-	-	A	①	
Load Regulation (WLP-5-02)	ΔV _{OUT}	1mA ≤ I _{OUT} ≤ 1A	-	13	26	mV	①	
Load Regulation (USP-6C, SOT-26W, SOT-89-5)	ΔV _{OUT}	1mA ≤ I _{OUT} ≤ 1A	-	37	68	mV	①	
Dropout Voltage	V _{dif} ⁽⁵⁾	I _{OUT} =1A	-	E-1 ⁽⁸⁾		mV	①	
Supply Current 1 ⁽⁹⁾	I _{BIAS}	I _{OUT} =0A	76	100	143	μA	②	
Supply Current 2	I _{IN}	I _{OUT} =0A V _{OUT(T)} < 1.2V V _{OUT(T)} ≥ 1.2V	0.1 3.9	- -	8.7 14.2	μA	②	
Stand-by Current 1	I _{BIAS_STB}	V _{BIAS} =6.0V, V _{IN} =3.0V, V _{CE} =V _{SS}	-	0.01	0.10	μA	②	
Stand-by Current 2	I _{IN_STB}	V _{BIAS} =6.0V, V _{IN} =3.0V, V _{CE} =V _{SS}	-	0.01	0.15	μA	②	
Bias Line Regulation	ΔV _{OUT} / (ΔV _{BIAS} · V _{OUT})	V _{OUT(T)} ≤ 1.2V, V _{CE} =V _{BIAS} 2.5V ≤ V _{BIAS} ≤ 6.0V V _{OUT(T)} > 1.2V, V _{CE} =V _{BIAS} V _{OUT(T)} +1.3V ≤ V _{BIAS} ≤ 6.0V	-	0.01	0.10	%/V	①	
Input Line Regulation	ΔV _{OUT} / (ΔV _{IN} · V _{OUT})	V _{OUT(T)} +0.1V ≤ V _{IN} ≤ 3.0V	-	0.01	0.10	%/V	①	
Bias UVLO Voltage	V _{BIAS_UVLOD}		V _{SS}	-	1.28	V	①	
Bias UVLO Release Voltage	V _{BIAS_UVLOR}		2.5	-	6.0	V	①	
Input UVLO Voltage	V _{IN_UVLOD}		V _{SS}	-	0.23	V	①	
Input UVLO Release Voltage	V _{IN_UVLOR}		0.5	-	3.0	V	①	
Output Voltage Temperature Characteristics	ΔV _{OUT} / (ΔT _{opr} · V _{OUT})	I _{OUT} =100mA -40°C ≤ T _{opr} ≤ 85°C	-	±30	-	ppm/°C	①	
Bias Ripple Rejection Ratio	V _{BIAS_PSR}	V _{BIAS} =V _{CE} =3.6V _{DC} +0.2V _{p-pAC} I _{OUT} =100mA, f=1kHz, C _{BIAS} =OPEN	-	60	-	dB	③	
Input Ripple Rejection Ratio	V _{IN_PSR}	V _{IN} =V _{OUT(T)} +0.3V _{DC} +0.2V _{p-pAC} I _{OUT} =100mA, f=1kHz, C _{IN} =OPEN	-	75	-	dB	③	
Limit Current ⁽⁴⁾	I _{LIM}	V _{OUT} =V _{OUT(E)} × 0.95	1.0	1.3	-	A	①	
Short Current	I _{SHORT}	V _{OUT} =V _{SS}	-	90	-	mA	①	
Thermal Shutdown Detect Temperature	T _{TSD}	Junction Temperature	-	150	-	°C	①	
Thermal Shutdown Release Temperature	T _{TSR}	Junction Temperature	-	125	-	°C	①	
Thermal Shutdown Hysteresis Width	T _{TSD} - T _{TSR}	Junction Temperature	-	25	-	°C	①	
C _L Auto-Discharge Resistance	R _{DCHG}	V _{CE} =V _{SS} , V _{OUT} =V _{OUT(T)}	130	190	255	Ω	①	
CE "H" Level Voltage	V _{CEH}		0.65	-	6.00	V	④	
CE "L" Level Voltage	V _{CEL}		V _{SS}	-	0.41	V	④	
CE "H" Level Current	I _{CEH}	V _{BIAS} =V _{CE} =6.0V	3.2	6.0	10.6	μA	④	
CE "L" Level Current	I _{CEL}	V _{BIAS} =6.0V, V _{CE} =V _{SS}	-0.1	-	0.1	μA	④	
Soft-Start Time (Type A) ⁽¹⁰⁾	t _{SS}	V _{CE} =0V → 3.6V, tr=5 μs	225	430	600	μs	⑤	
Output Rise Time (Type B) ⁽¹⁰⁾	t _{ON}	V _{CE} =0V → 3.6V, tr=5 μs	-	-	110	μs	⑤	
Inrush Current (Type A)	I _{RUSH}	C _L =2.2 μF	V _{OUT(T)} ≤ 1.2V	-	-	70	mA	⑤
			V _{OUT(T)} > 1.2V	-	-	85	mA	⑤
		C _L =10 μF	V _{OUT(T)} ≤ 1.2V	-	-	155	mA	⑤
			V _{OUT(T)} > 1.2V	-	-	215	mA	⑤

* 1: Unless otherwise stated, V_{BIAS}=V_{CE}=3.6V, V_{IN}=V_{OUT(T)}+0.3V, I_{OUT}=1mA, C_{BIAS}=C_{IN}=1.0 μF, C_L=2.2 μF

* 2: V_{OUT(E)} = Effective output voltage

* 3: V_{OUT(T)} = Nominal output voltage

* 4: Mount conditions affect heat dissipation. Maximum output current is not guaranteed when TSD starts to operate earlier.

* 5: V_{dif} = {V_{IN1}⁽⁶⁾ - V_{OUT1}⁽⁷⁾}

* 6: V_{IN1} is an input voltage when V_{OUT1} appears at the output during decreasing input voltage gradually.

* 7: V_{OUT1} is a voltage equal to 98% of the output voltage where V_{BIAS}=V_{CE}=3.6 and V_{IN}=V_{OUT(T)}+0.3V at I_{OUT}=1A is input to the V_{IN} pin.

* 8: Please refer to the table E-1 named DROPOUT VOLTAGE CHART

* 9: Supply current 1 may be fluctuated because that some bias current flows into the output.

* 10: A time between the CE input goes over the CE H threshold and the output reaches V_{OUT(E)} × 0.9V.

■ ELECTRICAL CHARACTERISTICS (Continued)

● OUTPUT VOLTAGE CHART (WLP-5-02)

NOMINAL OUTPUT VOLTAGE	E-1														
	DROPOUT VOLTAGE (mV)														
	V _{BIAS} =3.0V			V _{BIAS} =3.3V			V _{BIAS} =3.6V			V _{BIAS} =4.2V			V _{BIAS} =5.0V		
	V _{GS}	Vdif(mV)		V _{GS}	Vdif(mV)		V _{GS}	Vdif(mV)		V _{GS}	Vdif(mV)		V _{GS}	Vdif(mV)	
V _{OUT(T)}	(V)	TYP.	MAX.	(V)	TYP.	MAX.	(V)	TYP.	MAX.	(V)	TYP.	MAX.	(V)	TYP.	MAX.
0.5	2.5	79	134	2.8	76	129	3.1	76	129	3.7	73	124	4.5	72	122
0.6	2.4	82	139	2.7			3.0			3.6			4.4		
0.7	2.3			2.6	2.9	3.5	4.3								
0.8	2.2	85	144	2.5	79	134	2.8	3.4	4.2						
0.9	2.1	88	149	2.4	82	139	2.7	3.3	4.1						
1.0	2.0	91	154	2.3			2.6	3.2	4.0						
1.1	1.9	94	159	2.2	85	144	2.5	79	134	3.1	3.9				
1.2	1.8	100	169	2.1	88	149	2.4	82	139	3.0	3.8	73	124		
1.3	1.7	109	184	1.9	91	154	2.3			2.9	3.7				
1.4	1.6	118	199	1.9	94	159	2.2	85	144	2.8	3.6				
1.5	1.5	130	219	1.8	100	169	2.1	88	149	2.7	3.5				
1.6	1.4	144	244	1.7	109	184	2.0	91	154	2.6	3.4				
1.7	1.3	171	289	1.6	118	199	1.9	94	159	2.5	79	134	3.3		
1.8	1.2	201	339	1.5	130	219	1.8	100	169	2.4	82	139	3.2	76	129

* Dropout voltage is defined as the $V_{GS}(=V_{BIAS}-V_{OUT(E)})$ of the driver transistor.

● OUTPUT VOLTAGE CHART (USP-6C,SOT-26W,SOT-89-5)

NOMINAL OUTPUT VOLTAGE	E-1														
	DROPOUT VOLTAGE (mV)														
	V _{BIAS} =3.0V			V _{BIAS} =3.3V			V _{BIAS} =3.6V			V _{BIAS} =4.2V			V _{BIAS} =5.0V		
	V _{GS}	Vdif (mV)		V _{GS}	Vdif (mV)		V _{GS}	Vdif (mV)		V _{GS}	Vdif (mV)		V _{GS}	Vdif (mV)	
V _{OUT(T)}	(V)	TYP.	MAX.	(V)	TYP.	MAX.	(V)	TYP.	MAX.	(V)	TYP.	MAX.	(V)	TYP.	MAX.
0.5	2.5	152	218	2.8	146	213	3.1	146	213	3.7	140	208	4.5	137	206
0.6	2.4	155	223	2.7			3.0			3.6			4.4		
0.7	2.3			2.6	2.9	3.5	4.3								
0.8	2.2	158	228	2.5	152	218	2.8	3.4	4.2						
0.9	2.1	162	233	2.4	155	223	2.7	3.3	4.1						
1.0	2.0	165	238	2.3			2.6	3.2	4.0						
1.1	1.9	167	243	2.2	158	228	2.5	152	218	3.1	3.9				
1.2	1.8	169	253	2.1	162	233	2.4	155	223	3.0	3.8	140	208		
1.3	1.7	179	268	2.0	165	238	2.3			2.9	3.7				
1.4	1.6	189	283	1.9	167	243	2.2	158	228	2.8	3.6				
1.5	1.5	202	303	1.8	169	253	2.1	162	233	2.7	3.5				
1.6	1.4	213	328	1.7	179	268	2.0	165	238	2.6	3.4				
1.7	1.3	225	373	1.6	189	283	1.9	167	243	2.5	152	218	3.3		
1.8	1.2	255	423	1.5	202	303	1.8	169	253	2.4	155	223	3.2	146	213

* Dropout voltage is defined as the $V_{GS}(=V_{BIAS}-V_{OUT(E)})$ of the driver transistor.

OPERATIONAL EXPLANATION

The voltage divided by resistors R1 and R2 is compared with the internal reference voltage by the error amplifier. The V_{OUT} pin is then driven by the subsequent output signal. The output voltage at the V_{OUT} pin is controlled and stabilized by a system of negative feedback.

V_{BIAS} pin is power supply pin for output voltage control circuit, protection circuit and CE circuit. Also, the V_{BIAS} pin supplies some current as output current. V_{IN} pin is connected to a driver transistor and provides output current.

In order to obtain high efficient output current through low on-resistance, please take enough $V_{GS} (=V_{BIAS} - V_{OUT(E)})$ of the driver transistor.

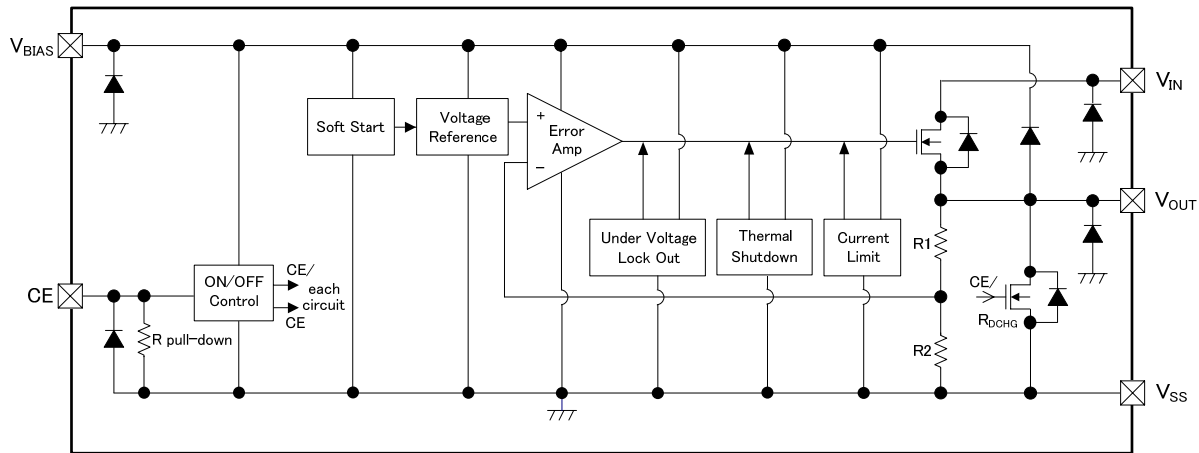

Figure1: XC6602 Series, Type A

<Soft-Start Function>

With the XC6602 (Type A), the inrush current (I_{RUSH}) from V_{IN} to V_{OUT} for charging C_L at start-up can be reduced and makes the V_{IN} stable.

As for the XC6602, the soft-start time in the type A is optimized internally. On the other hand, the type B of the XC6602 does not have the soft-start time function.

<Current Limiter, Short-Circuit Protection>

The XC6602 series includes a combination of a fixed current limiter circuit and a foldback short-circuit protection. When the output current reaches the current limit, the output voltage drops and this operation makes the output current foldback to be decreased.

<Thermal Shutdown Circuit (TSD) >

When the junction temperature of the built-in driver transistor reaches the temperature limit, the thermal shutdown circuit operates and the driver transistor will be set to OFF. The IC resumes its operation when the thermal shutdown function is released and the IC's operation is automatically restored because the junction temperature drops to the level of the thermal shutdown release temperature.

<Under Voltage Lock Out (UVLO) >

When the V_{BIAS} pin and V_{IN} pin voltage drops, the output driver transistor is set to OFF by UVLO function to prevent false output caused by unstable operation of the internal circuitry. When the V_{BIAS} pin voltage and the V_{IN} pin voltage rises at release voltage, the UVLO function is released. The driver transistor is turned ON and start to operate voltage regulation.

■ OPERATIONAL EXPLANATION (Continued)

<CE Pin>

The XC6602 internal circuitry can be shutdown via the signal to the CE pin. In shutdown mode with CE low level voltage, the V_{OUT} pin will be pulled down to the V_{SS} level via C_L discharge resistance (R_{DCHG}) placed in parallel to R1 and R2.

The CE pin has pull-down circuitry so that CE input current flows during IC operation. If the CE pin voltage is taken from V_{BIAS} pin or V_{SS} pin then logic is fixed and the IC will operate normally. However, supply current may increase as a result of through current in the IC's internal circuitry when medium voltage is input.

<CL High Speed Auto-Discharge>

XC6602 series can quickly discharge the electric charge at the output capacitor (C_L) via the internal transistor located between the V_{OUT} pin and the V_{SS} pin when a low signal to the CE pin which enables a whole IC circuit put into OFF state. When the IC is disabled, electric charge at the output capacitor (C_L) is quickly discharged so that it could avoid malfunction. Discharge time of the output capacitor (C_L) is set by the C_L auto-discharge resistance (R_{DCHG}) and the output capacitor (C_L). By setting time constant of a C_L auto-discharge resistance value (R_{DCHG}) and an output capacitor value (C_L) as τ ($\tau = C_L \times R_{DCHG}$), the output voltage after discharge via the internal transistor is calculated by the following formula. Please also note R_{DCHG} is depended on V_{BIAS} . When V_{BIAS} is larger, R_{DCHG} is smaller.

$$V = V_{OUT(E)} \times e^{-t/\tau} \text{ or } t = \tau \ln(V_{OUT(E)} / V)$$

(V: Output voltage after discharge, $V_{OUT(E)}$: Initial Output voltage, t: Discharge time,
 τ : C_L auto-discharge resistance $R_{DCHG} \times C_L$ Output capacitance)

<Low ESR Capacitor>

With the XC6602 series, a stable output voltage is achievable even if used with low ESR capacitors, as a phase compensation circuit is built-in. The output capacitor (C_L) should be connected as close to V_{OUT} pin and V_{SS} pin to obtain stable phase compensation. Values required for the phase compensation are as the table below.

For a stable power input, please connect an bias capacitor (C_{BIAS}) between the V_{BIAS} pin and the V_{SS} pin. Also, please connect an input capacitor (C_{IN}) between the V_{IN} pin and the V_{SS} pin. In order to ensure the stable phase compensation while avoiding run-out of values, please use the capacitor (C_{BIAS} , C_{IN} , C_L) which does not depend on bias or temperature too much. The table below shows recommended values of C_{BIAS} , C_{IN} , C_L .

CHART 1 : Recommended Values of C_{BIAS} , C_{IN} , C_L (MIN.)

OUTPUT VOLTAGE RANGE $V_{OUT(T)}$	BIAS CAPACITOR C_{BIAS}	INPUT CAPACITOR C_{IN}	OUTPUT CAPACITOR C_L
0.5V~1.8V	1.0 μ F	1.0 μ F	2.2 μ F

■ NOTES ON USE

1. For temporary, transitional voltage drop or voltage rising phenomenon, the IC is liable to malfunction should the ratings be exceeded.
2. Where wiring impedance is high, operations may become unstable due to noise and/or phase lag depending on output current. Please keep the resistance low for the V_{BIAS} , V_{IN} and V_{SS} wiring in particular.
3. Please wire the C_{BIAS} , C_{IN} and C_L as close to the IC as possible.
4. Capacitances of these capacitors (C_{BIAS} , C_{IN} , C_L) are decreased by the influences of bias voltage and ambient temperature. Care shall be taken for capacitor selection to ensure stability of phase compensation from the point of ESR influence.
5. When it is used in a quite small input / output dropout voltage, output may go into unstable operation. Please test it thoroughly before using it in production.
6. Torex places an importance on improving our products and their reliability.
We request that users incorporate fail-safe designs and post-aging protection treatment when using Torex products in their systems
7. Note on mounting (WLP-5-02)
 - (1) Mount pad design should be optimized for user's conditions.
 - (2) Sn-AG-Cu is used for the package terminals. If eutectic solder is used, mounting reliability is decreased. Please do not use eutectic solder paste.
 - (3) When underfill agent is used to increase interfacial bonding strength, please take enough evaluation for selection. Some underfill materials and applied conditions may decrease bonding reliability.
 - (4) The IC has exposed surface of silicon material in the top marking face and sides so that it is weak against mechanical damages. Please take care of handling to avoid cracks and breaks.
 - (5) The IC has exposed surface of silicon material in the top marking face and sides. Please use the IC with keeping the circuit open (avoiding short-circuit from the out).
 - (6) Semi-transparent resin is coated on the circuit face of the package. Please be noted that the usage under strong lights may affects device performance.

TEST CIRCUITS

● Circuit ①

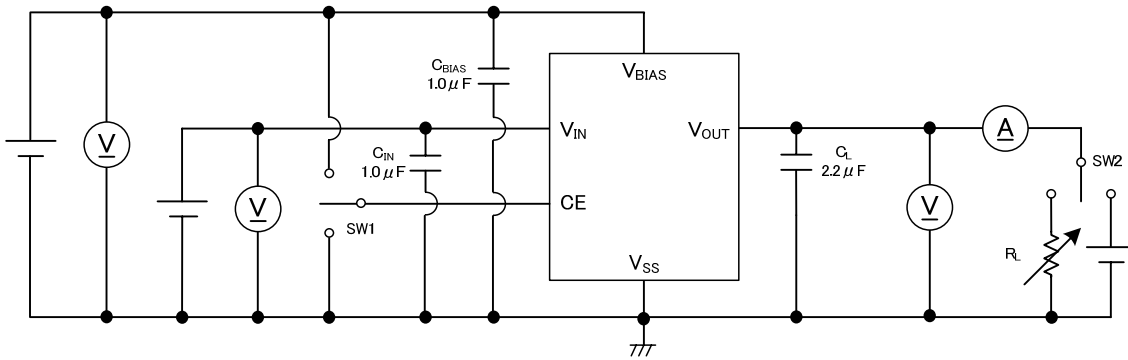

● Circuit ②

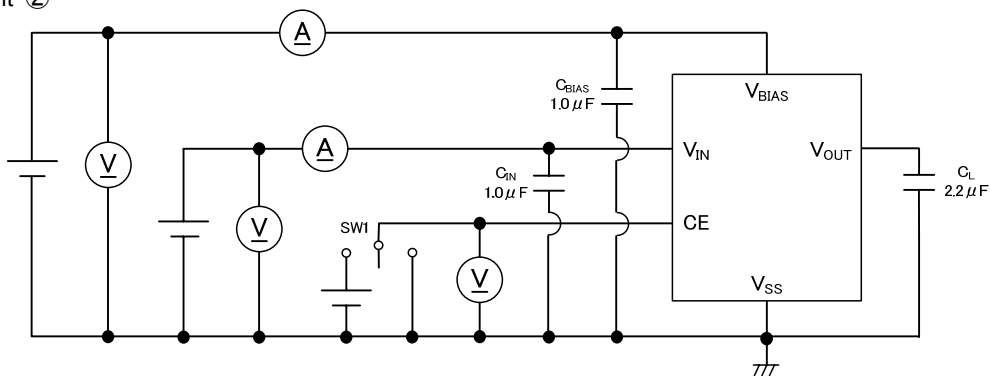

● Circuit ③

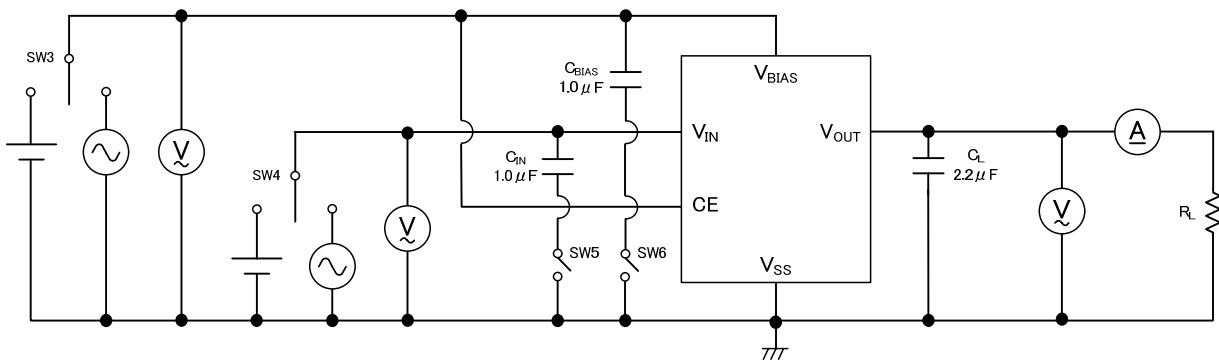

● Circuit ④

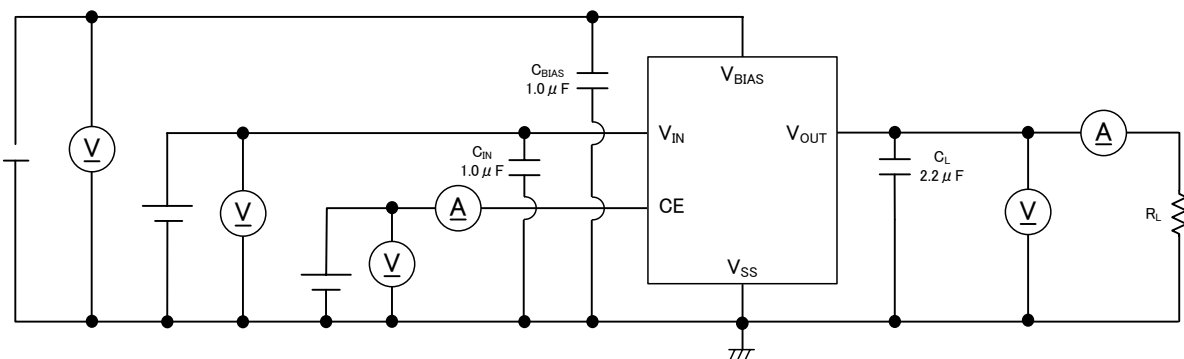

TEST CIRCUITS (Continued)

● Circuit ⑤ (Timing Chart)

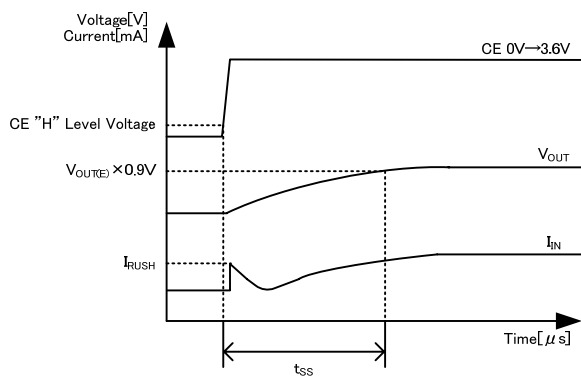
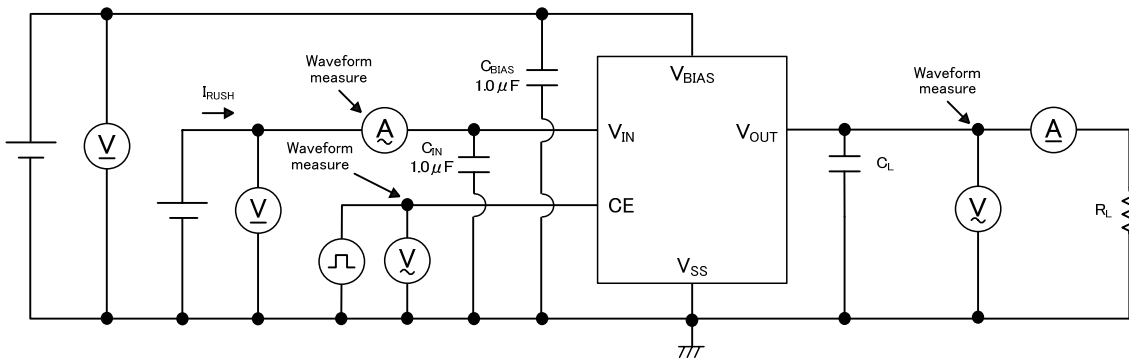

XC6602 Series, Type A

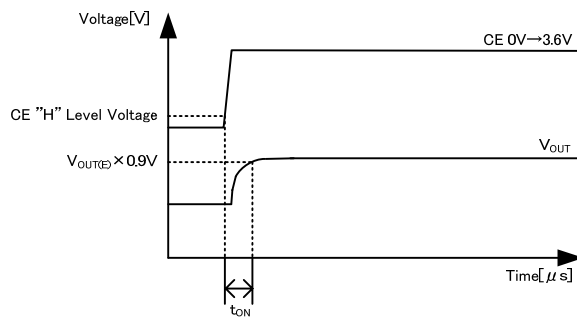

XC6602 Series, Type B

TYPICAL PERFORMANCE CHARACTERISTICS

* Unless otherwise stated, $V_{BIAS}=V_{CE}=3.6V$, $V_{IN}=V_{OUT(T)}+0.3V$, $I_{OUT}=1mA$, $C_{BIAS}=C_{IN}=1.0\mu F$, $C_L=2.2\mu F$, $T_a=25^\circ C$

(1) Output Voltage vs. Output Current

XC6602x051MR-G

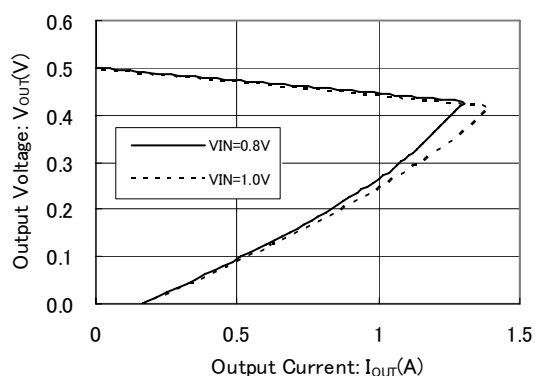

(2) Output Voltage vs. Bias Voltage

XC6602x051xR-G

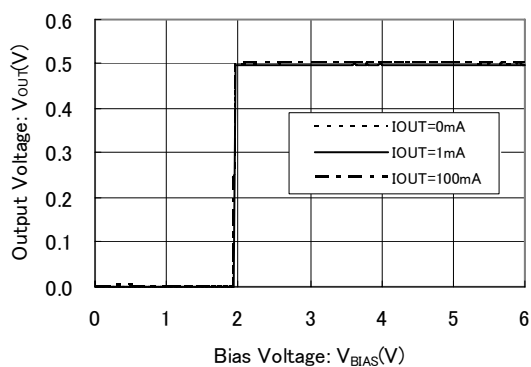

XC6602x121MR-G

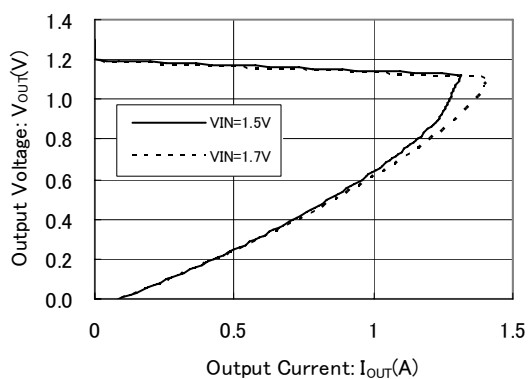

XC6602x121xR-G

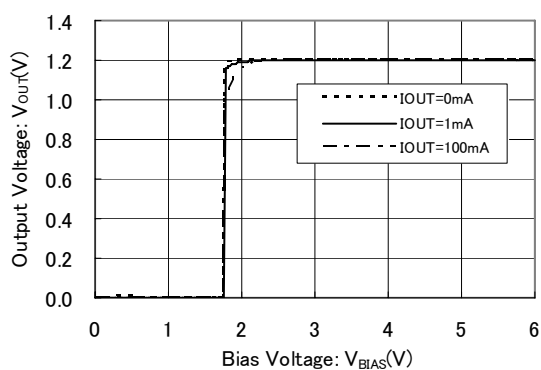

XC6602x181MR-G

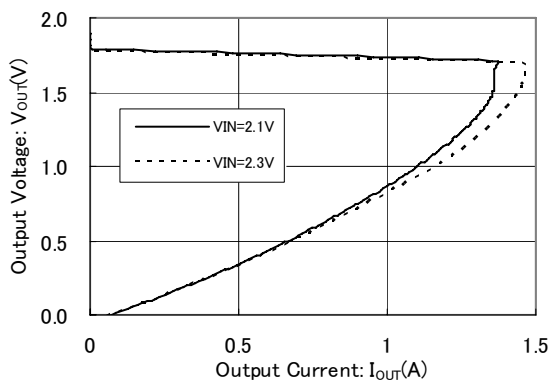

XC6602x181xR-G

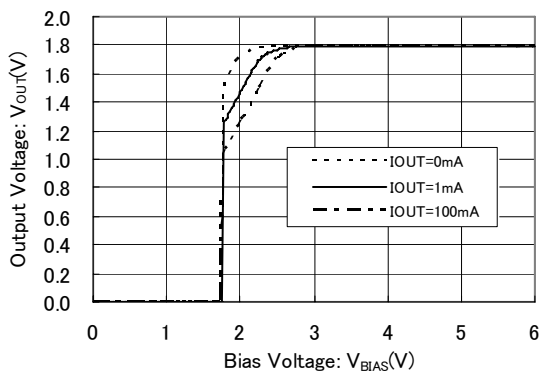

* Mount conditions affect heat dissipation. Thermal shutdown may start to operate before reaching the current limit.

TYPICAL PERFORMANCE CHARACTERISTICS (Continued)

* Unless otherwise stated, $V_{BIAS}=V_{CE}=3.6V$, $V_{IN}=V_{OUT(T)}+0.3V$, $I_{OUT}=1mA$, $C_{BIAS}=C_{IN}=1.0\mu F$, $C_L=2.2\mu F$, $T_a=25^\circ C$

(3) Output Voltage vs. Input Voltage

(4) Dropout Voltage vs. Output Current

XC6602x051xR-G

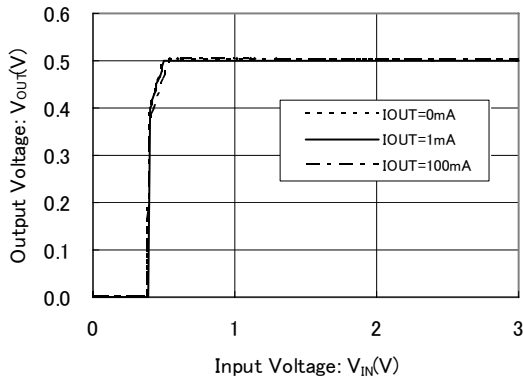

XC6602x121MR-G

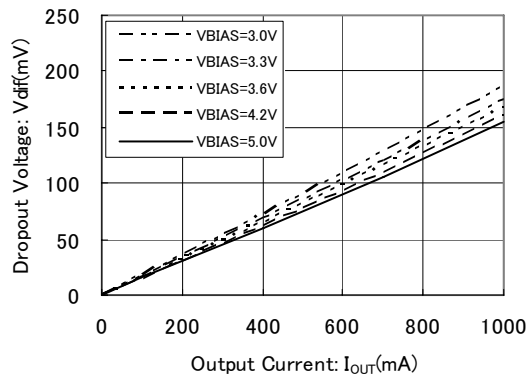

XC6602x121xR-G

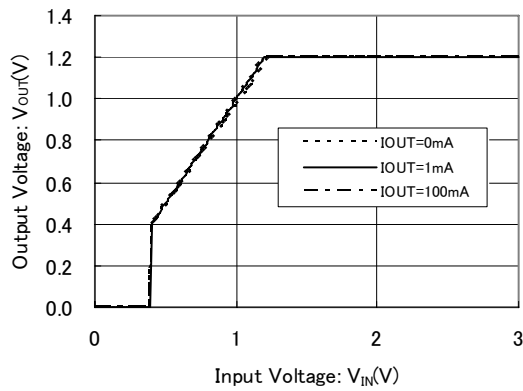

XC6602xxx1MR-G

$I_{OUT}=1A$

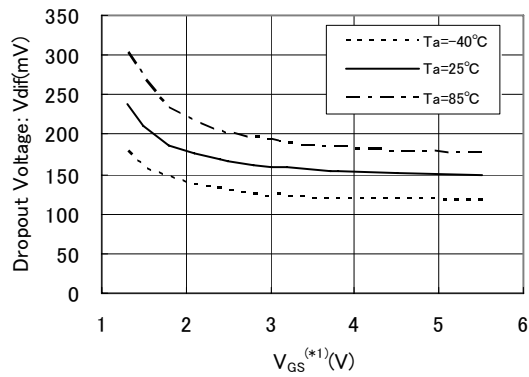

XC6602x181xR-G

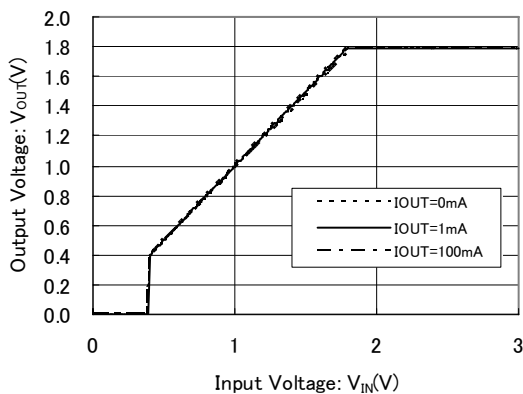

(*1) V_{GS} is a Gate-Source voltage of the driver transistor that is defined as the value of $V_{BIAS} - V_{OUT(E)}$.

A value of the dropout voltage is determined by the value of the V_{GS} .

TYPICAL PERFORMANCE CHARACTERISTICS (Continued)

* Unless otherwise stated, $V_{BIAS}=V_{CE}=3.6V$, $V_{IN}=V_{OUT(T)}+0.3V$, $I_{OUT}=1mA$, $C_{BIAS}=C_{IN}=1.0\mu F$, $C_L=2.2\mu F$, $T_a=25^\circ C$

(5) Supply Bias Current vs. Bias Voltage

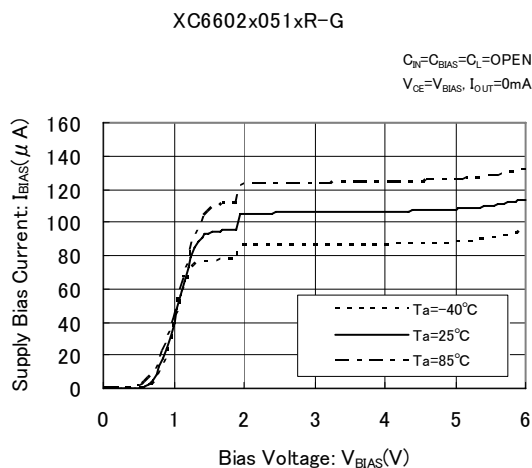

(6) Supply Input Current vs. Input Voltage

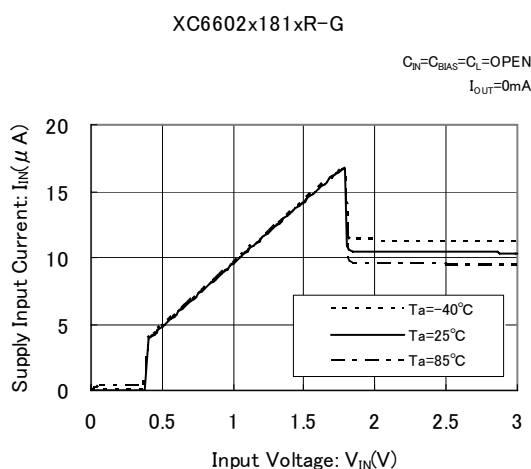
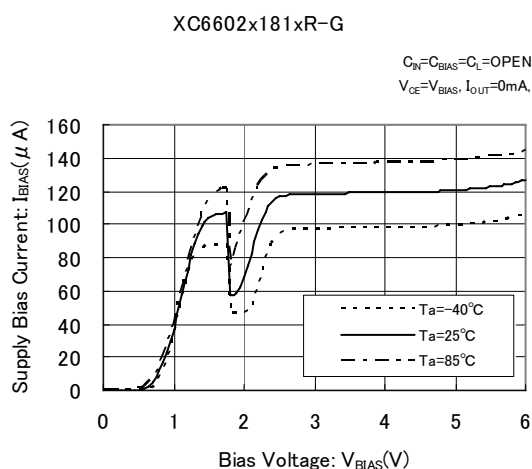
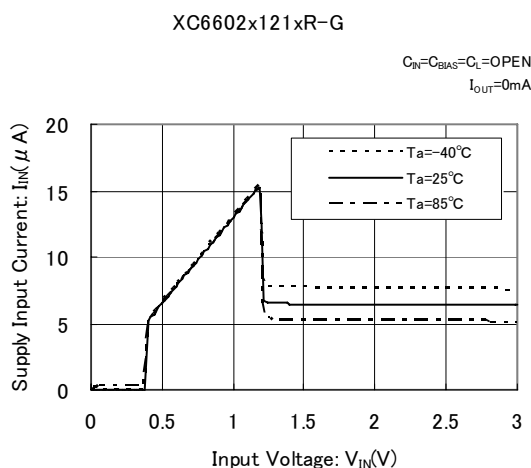
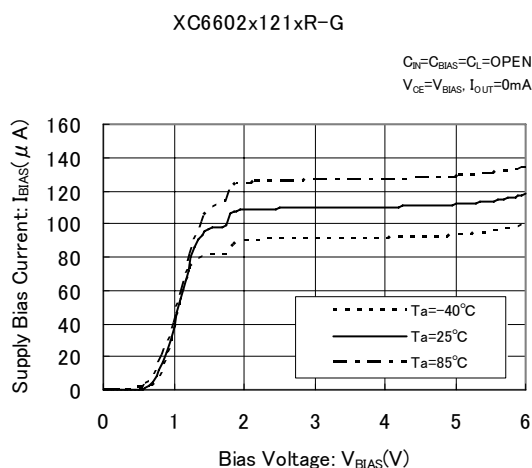
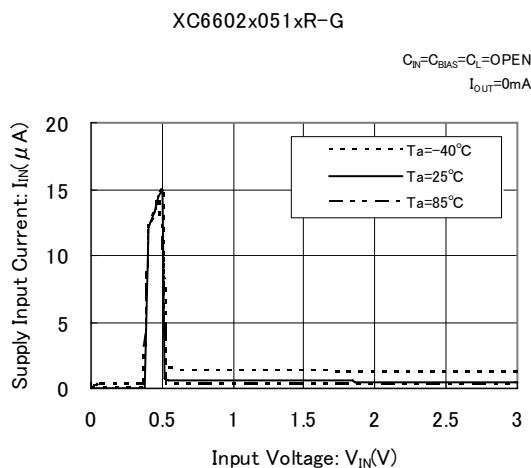

TYPICAL PERFORMANCE CHARACTERISTICS (Continued)

* Unless otherwise stated, $V_{BIAS}=V_{CE}=3.6V$, $V_{IN}=V_{OUT(T)}+0.3V$, $I_{OUT}=1mA$, $C_{BIAS}=C_{IN}=1.0\mu F$, $C_L=2.2\mu F$, $T_a=25^\circ C$

(7) Output Voltage vs. Ambient Temperature

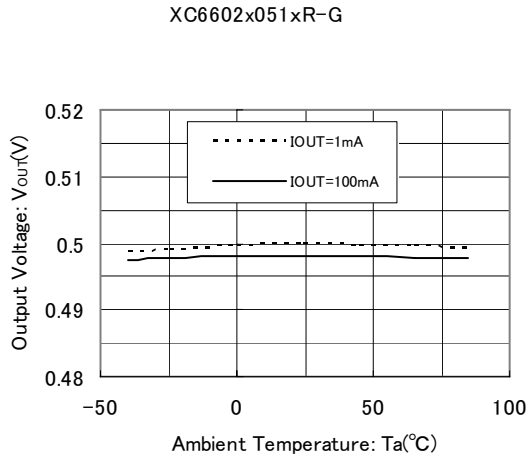

(8) Supply Bias Current vs. Ambient Temperature

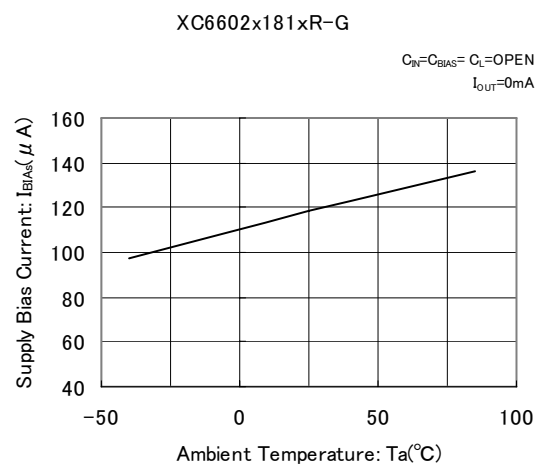
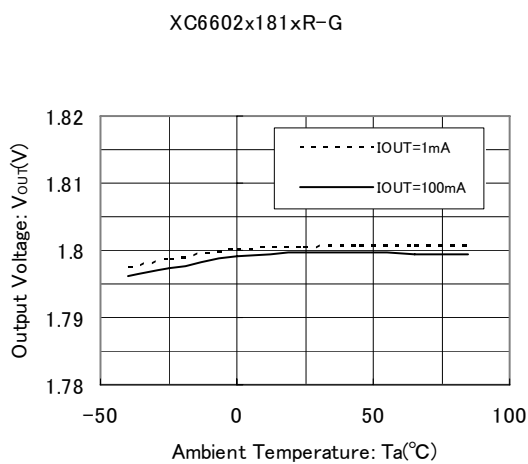
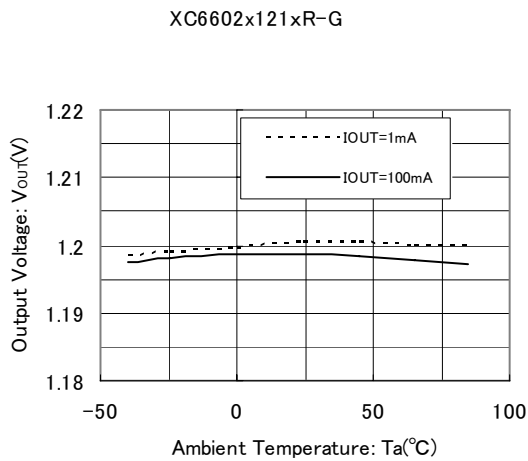
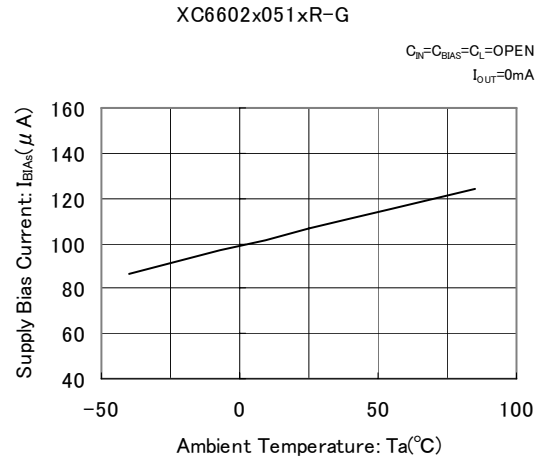

■ TYPICAL PERFORMANCE CHARACTERISTICS (Continued)

* Unless otherwise stated, $V_{BIAS}=V_{CE}=3.6V$, $V_{IN}=V_{OUT(T)}+0.3V$, $I_{OUT}=1mA$, $C_{BIAS}=C_{IN}=1.0\mu F$, $C_L=2.2\mu F$, $T_a=25^\circ C$

(9) Supply Input Current vs. Ambient Temperature

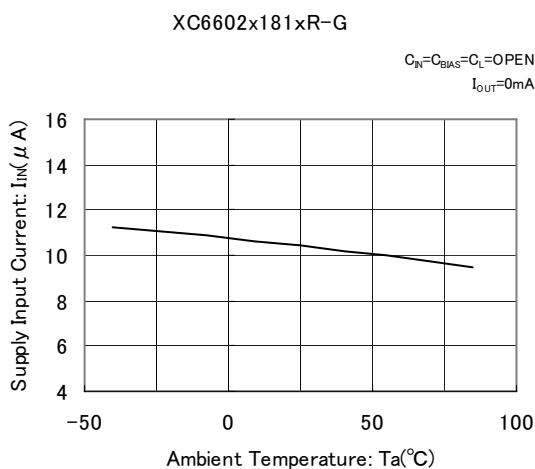
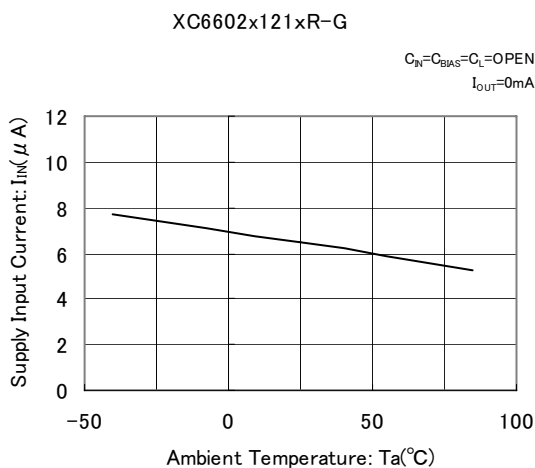
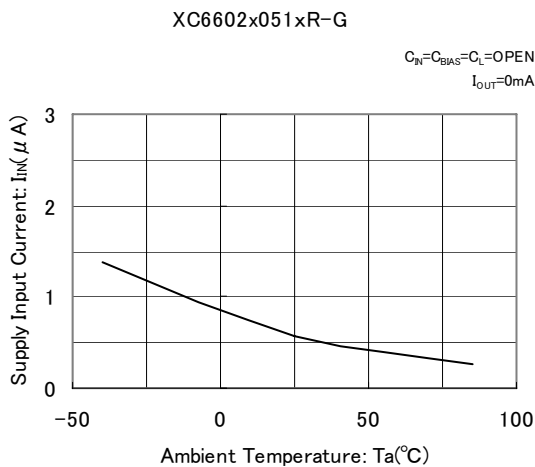

TYPICAL PERFORMANCE CHARACTERISTICS (Continued)

* Unless otherwise stated, $V_{BIAS}=V_{CE}=3.6V$, $V_{IN}=V_{OUT(T)}+0.3V$, $I_{OUT}=1mA$, $C_{BIAS}=C_{IN}=1.0\mu F$, $C_L=2.2\mu F$, $T_a=25^\circ C$

(10) Bias Transient Response

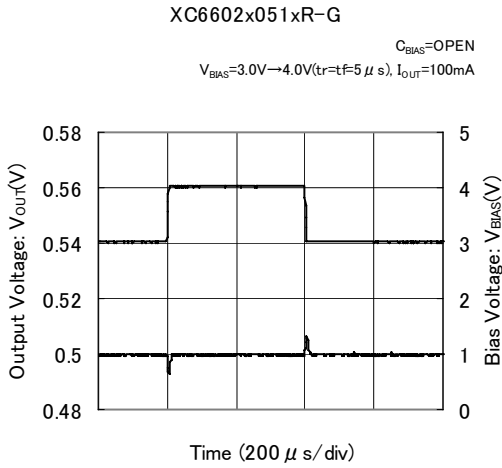

(11) Input Transient Response

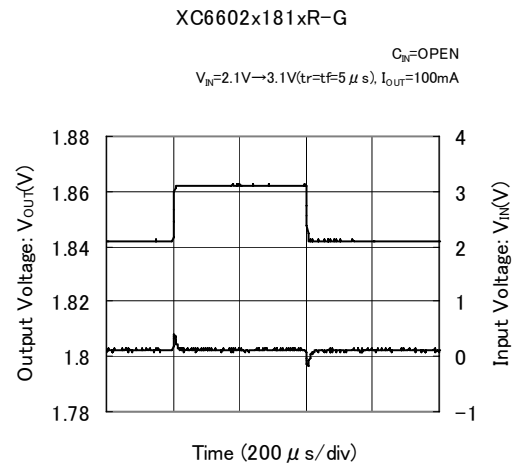
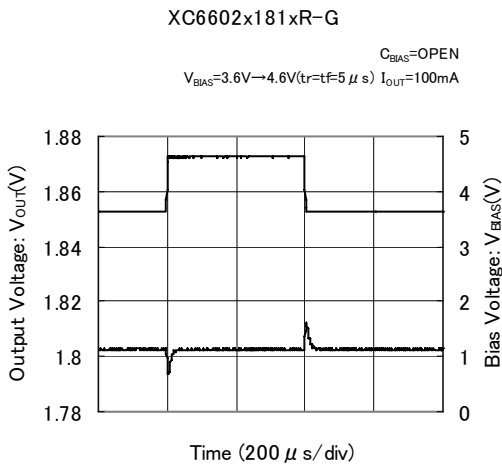
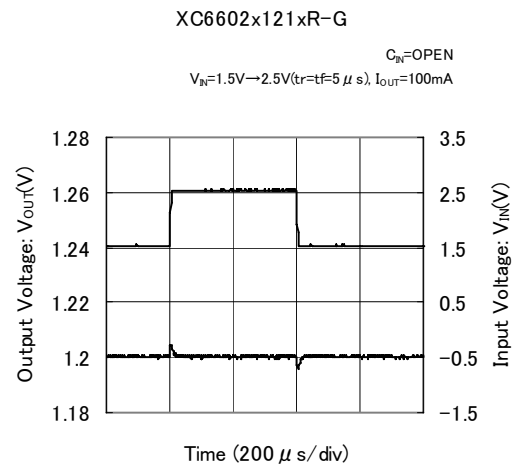
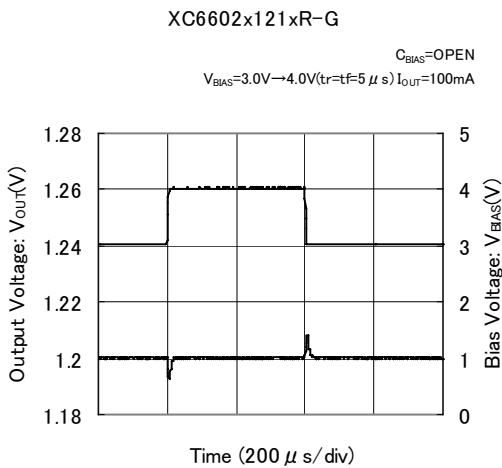
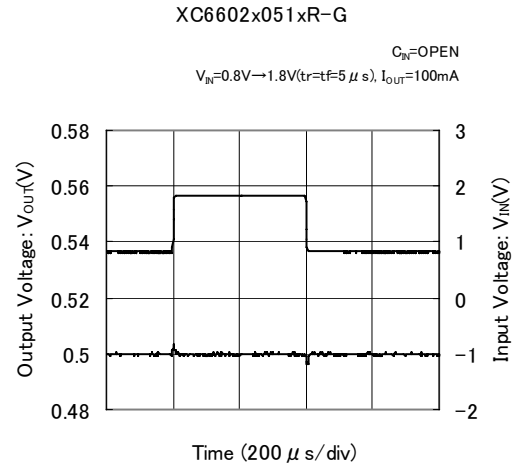

■ TYPICAL PERFORMANCE CHARACTERISTICS (Continued)

* Unless otherwise stated, $V_{BIAS}=V_{CE}=3.6V$, $V_{IN}=V_{OUT(T)}+0.3V$, $I_{OUT}=1mA$, $C_{BIAS}=C_{IN}=1.0\mu F$, $C_L=2.2\mu F$, $T_a=25^\circ C$

(12) Load Transient Response

XC6602x051xR-G

$I_{OUT}=1mA \Leftrightarrow 100mA (tr=tf=5\mu s)$

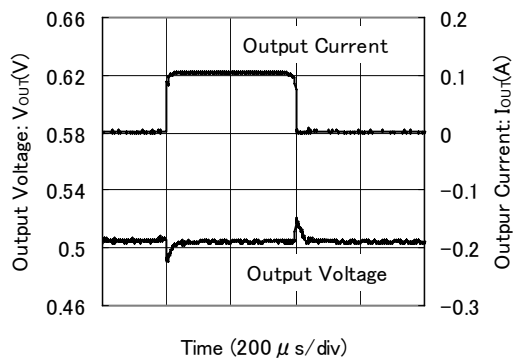

XC6602x121xR-G

$I_{OUT}=1mA \Leftrightarrow 100mA (tr=tf=5\mu s)$

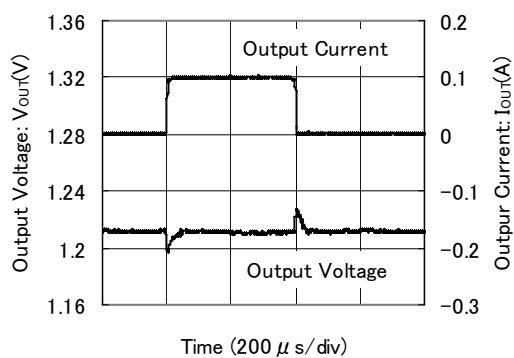

XC6602x181xR-G

$I_{OUT}=1mA \Leftrightarrow 100mA (tr=tf=5\mu s)$

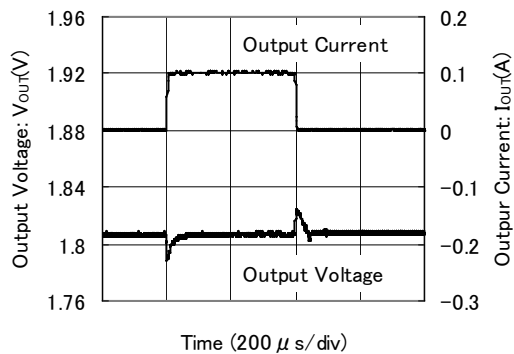

TYPICAL PERFORMANCE CHARACTERISTICS (Continued)

* Unless otherwise stated, $V_{BIAS}=V_{CE}=3.6V$, $V_{IN}=V_{OUT(T)}+0.3V$, $I_{OUT}=1mA$, $C_{BIAS}=C_{IN}=1.0\mu F$, $C_L=2.2\mu F$, $T_a=25^\circ C$

(13) CE Input Voltage Response

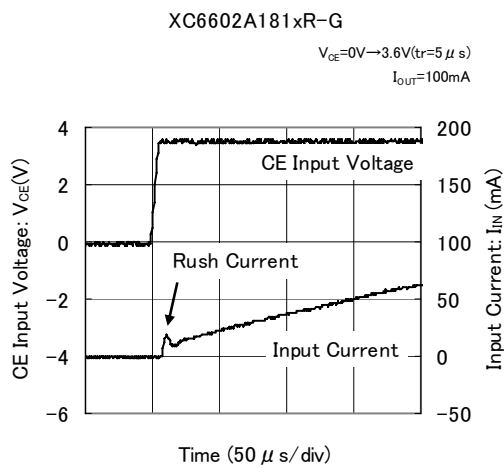
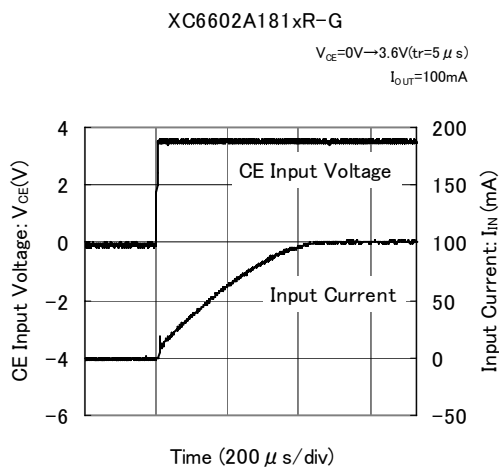
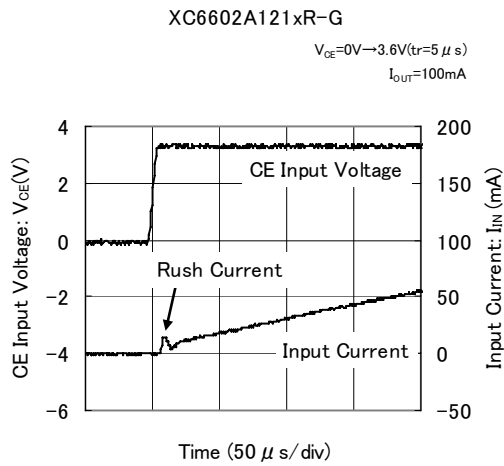
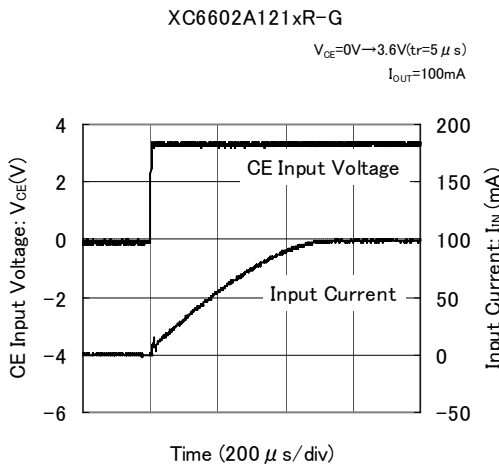
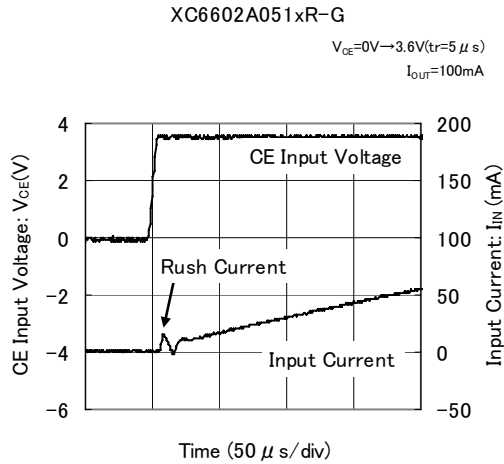
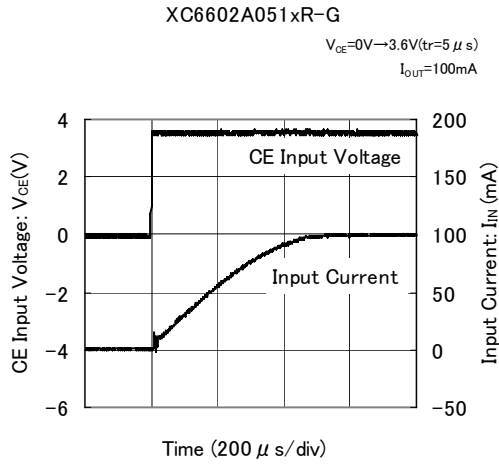

TYPICAL PERFORMANCE CHARACTERISTICS (Continued)

* Unless otherwise stated, $V_{BIAS}=V_{CE}=3.6V$, $V_{IN}=V_{OUT(T)}+0.3V$, $I_{OUT}=1mA$, $C_{BIAS}=C_{IN}=1.0\mu F$, $C_L=2.2\mu F$, $T_a=25^\circ C$

(13)CE Input Voltage Response (Continued)

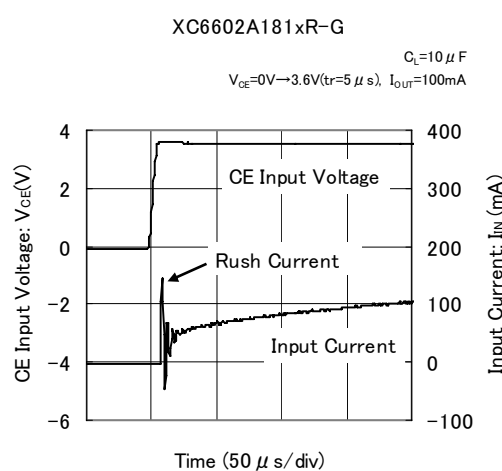
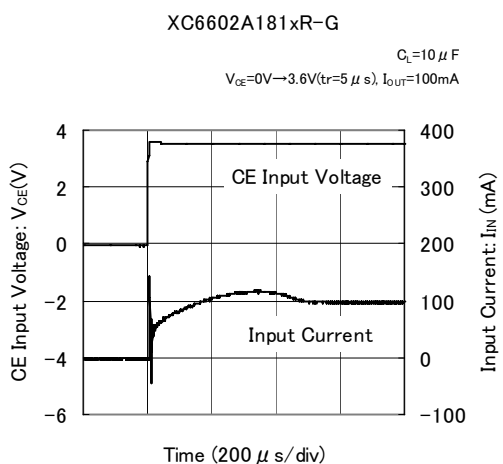
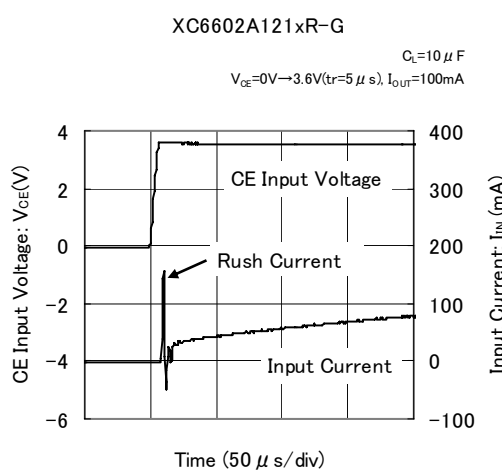
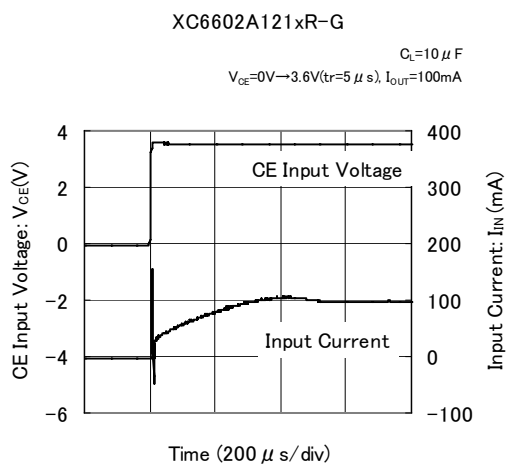
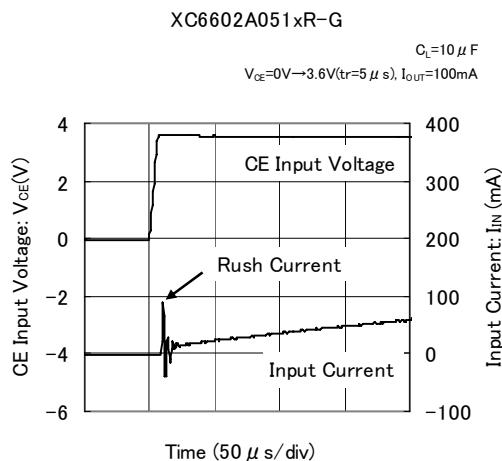
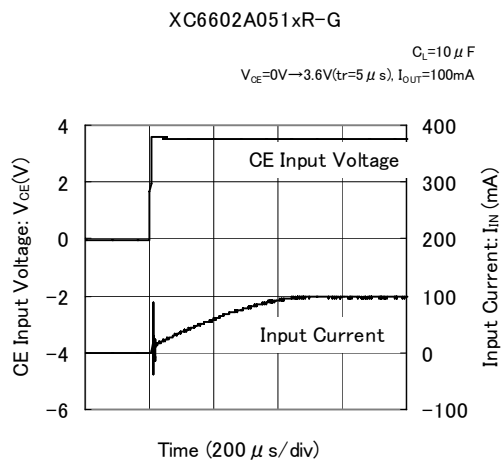

TYPICAL PERFORMANCE CHARACTERISTICS (Continued)

* Unless otherwise stated, $V_{BIAS}=V_{CE}=3.6V$, $V_{IN}=V_{OUT(T)}+0.3V$, $I_{OUT}=1mA$, $C_{BIAS}=C_{IN}=1.0\mu F$, $C_L=2.2\mu F$, $T_a=25^\circ C$

(14) CE Rising Response Time

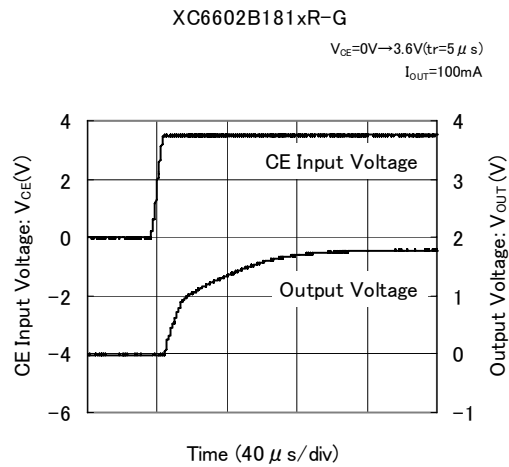
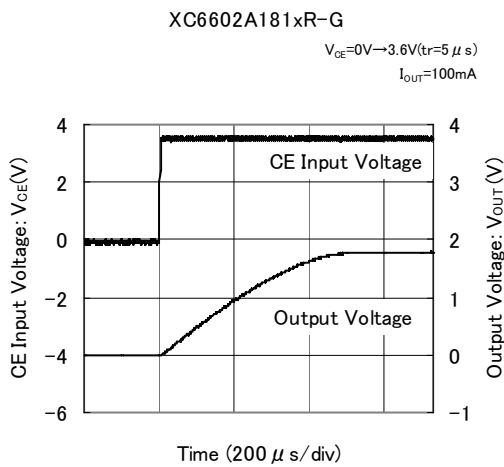
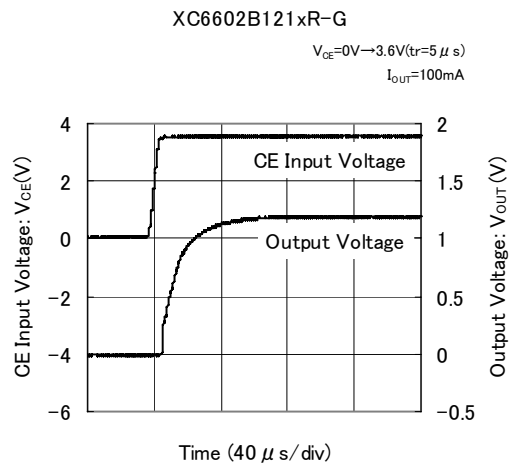
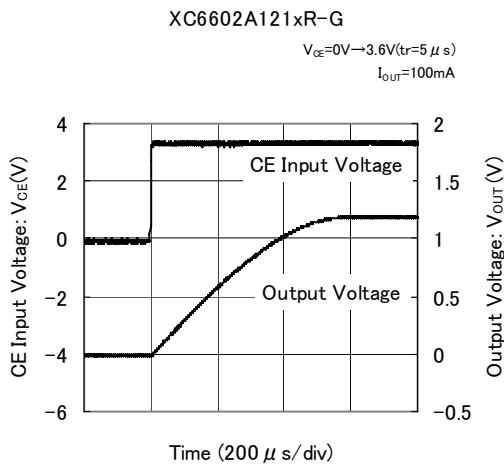
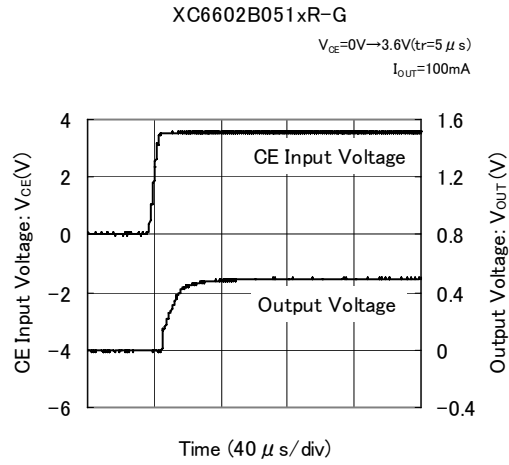
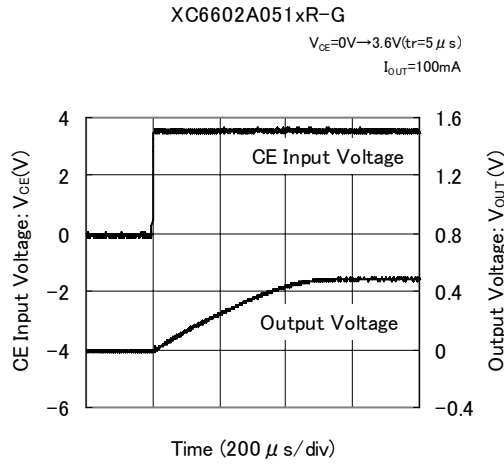

■ TYPICAL PERFORMANCE CHARACTERISTICS (Continued)

* Unless otherwise stated, $V_{BIAS}=V_{CE}=3.6V$, $V_{IN}=V_{OUT(T)}+0.3V$, $I_{OUT}=1mA$, $C_{BIAS}=C_{IN}=1.0\mu F$, $C_L=2.2\mu F$, $T_a=25^\circ C$

(15) V_{IN} Rising Response Time

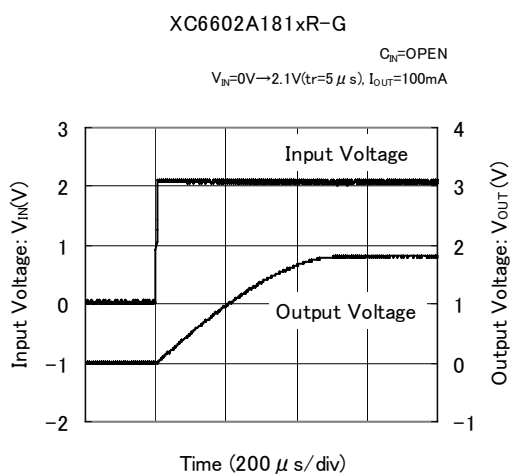
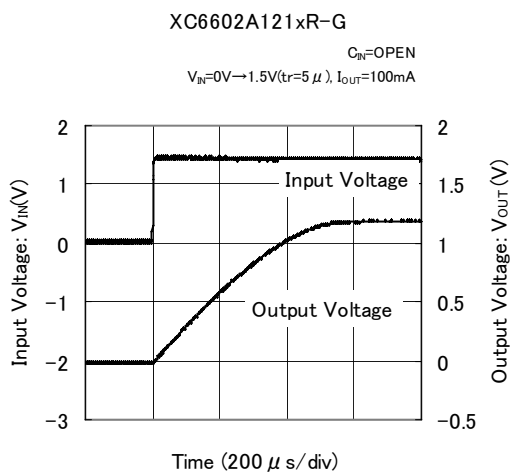
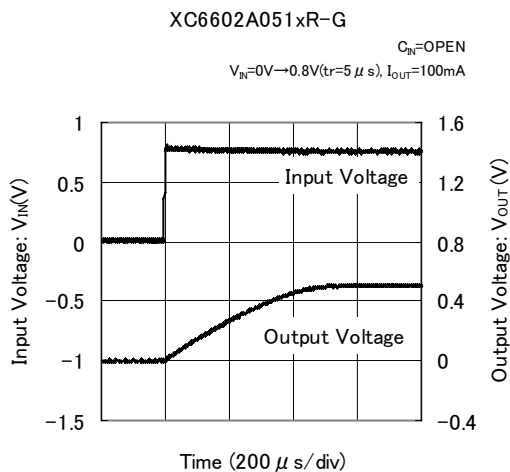

TYPICAL PERFORMANCE CHARACTERISTICS (Continued)

* Unless otherwise stated, $V_{BIAS}=V_{CE}=3.6V$, $V_{IN}=V_{OUT(T)}+0.3V$, $I_{OUT}=1mA$, $C_{BIAS}=C_{IN}=1.0\mu F$, $C_L=2.2\mu F$, $T_a=25^\circ C$

(16) Bias Voltage Ripple Rejection Rate

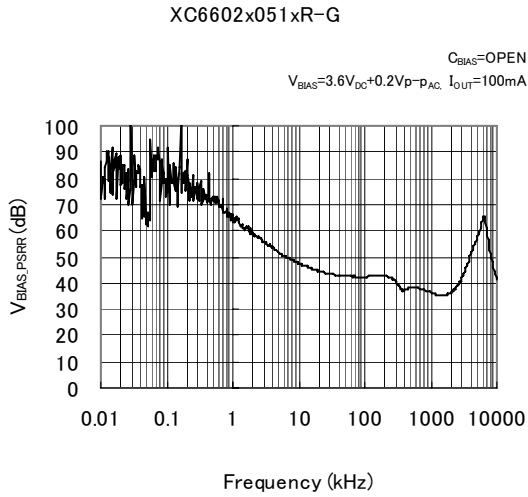

(17) Input Voltage Ripple Rejection Rate

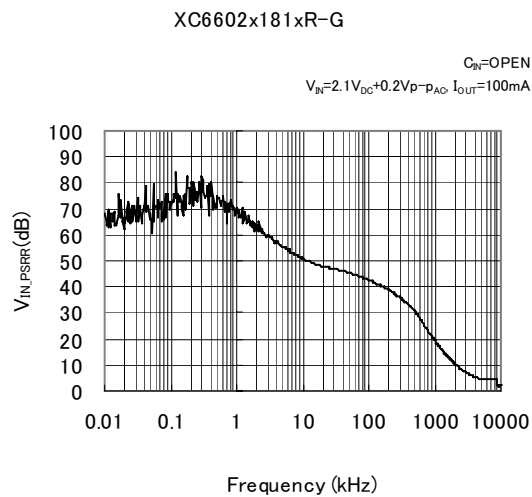
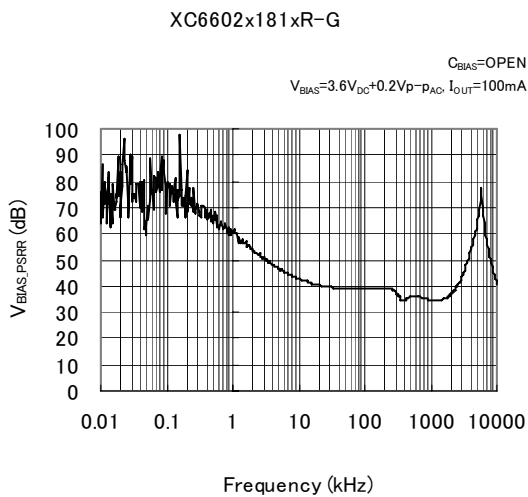
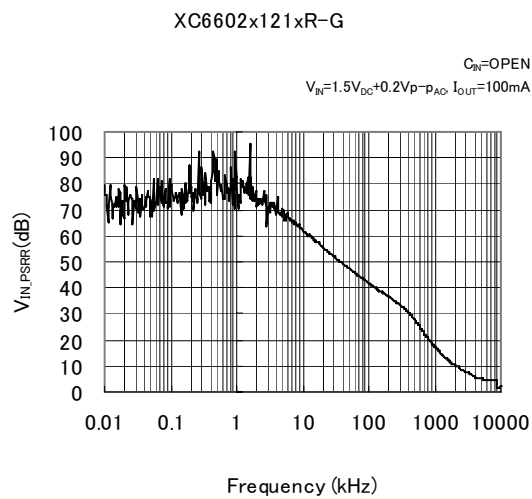
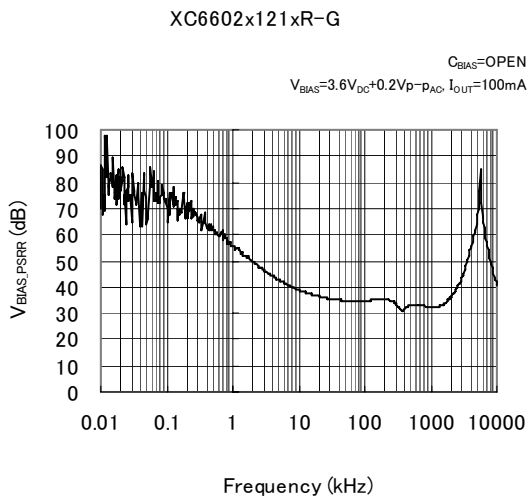
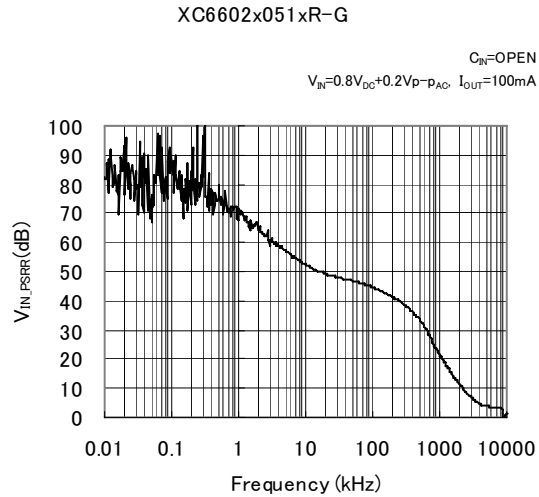

PACKAGING INFORMATION

USP-6C
(unit : mm)

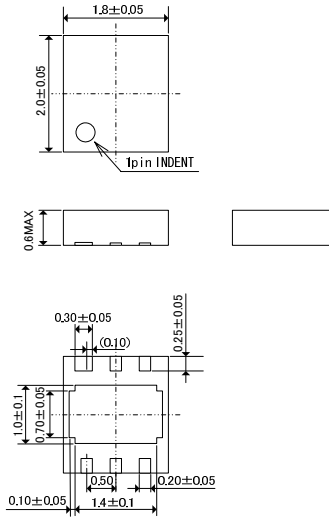

SOT-26W
(unit : mm)

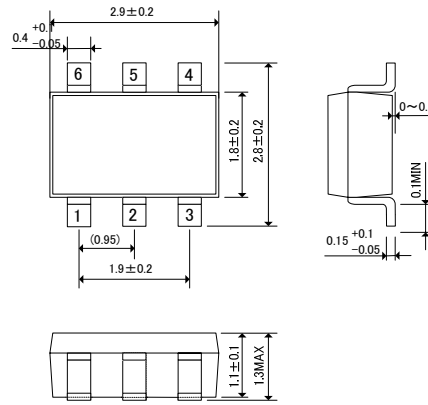

SOT-89-5
(unit : mm)

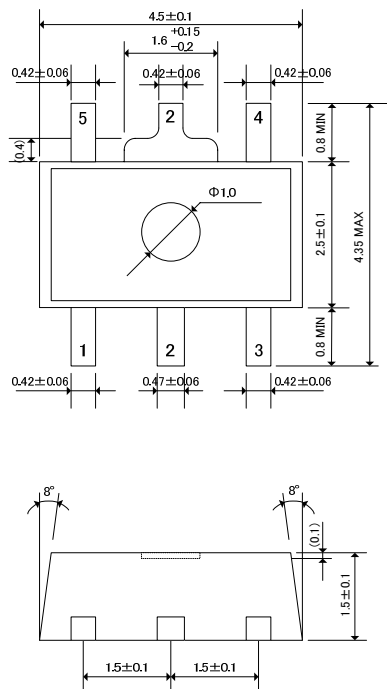

WLP-5-02
(unit : mm)

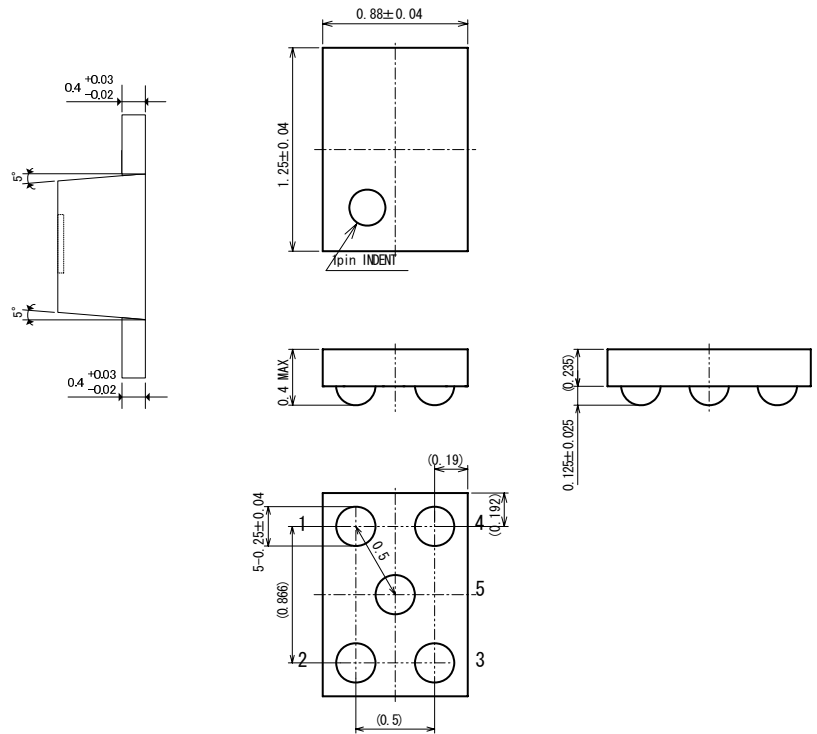

PACKAGING INFORMATION (Continued)

● USP-6C Reference Pattern Layout

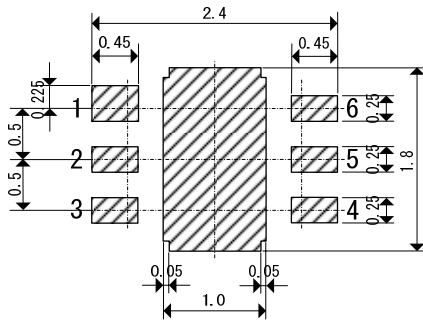

● USP-6C Reference Metal Mask Design

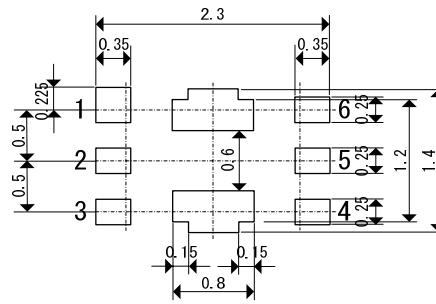

■ PACKAGING INFORMATION (Continued)

● USP-6C Power Dissipation

Power dissipation data for the USP-6C is shown in this page.
The value of power dissipation varies with the mount board conditions.
Please use this data as the reference data taken in the following condition.

1. Measurement Condition

- Condition: Mount on a board
- Ambient: Natural convection
- Soldering: Lead (Pb) free
- Board: Dimensions 40 x 40 mm (1600 mm² in one side)
Copper (Cu) traces occupy 50% of the board area
In top and back faces
Package heat-sink is tied to the copper traces

Material: Glass Epoxy (FR-4)

Thickness: 1.6 mm

Through-hole: 4 x 0.8 Diameter

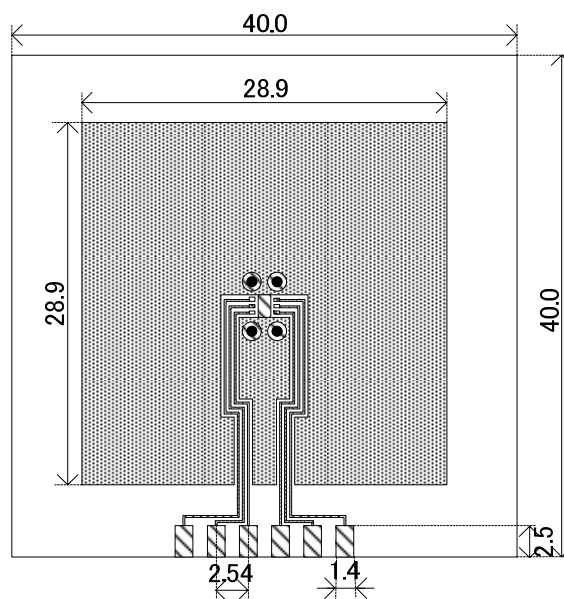

Evaluation Board (Unit: mm)

2. Power Dissipation vs. Ambient temperature

Board Mount ($T_j \text{ max} = 125^\circ\text{C}$)

Ambient Temperature ($^\circ\text{C}$)	Power Dissipation Pd (mW)	Thermal Resistance ($^\circ\text{C}/\text{W}$)
25	1000	100.00
85	400	

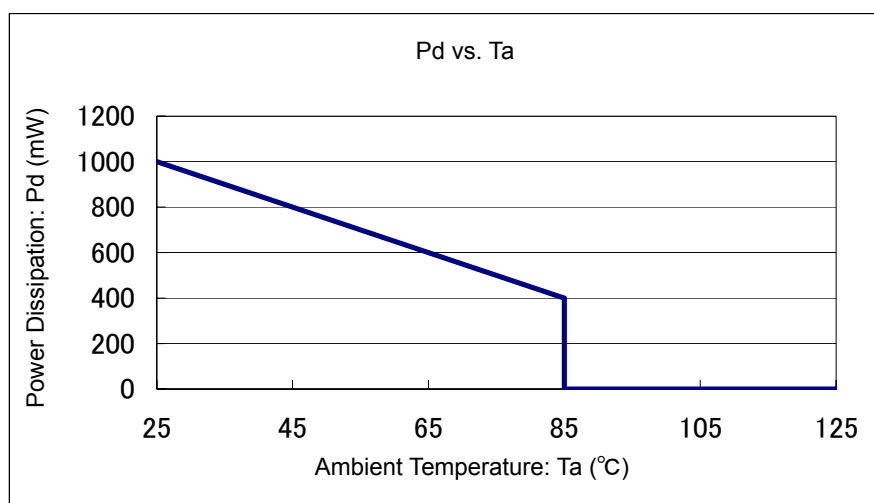

PACKAGING INFORMATION (Continued)

SOT-26W Power Dissipation

Power dissipation data for the SOT-26W is shown in this page.
 The value of power dissipation varies with the mount board conditions.
 Please use this data as the reference data taken in the following condition.

1. Measurement Condition

- Condition: Mount on a board
- Ambient: Natural convection
- Soldering: Lead (Pb) free
- Board: Dimensions 40 x 40 mm (1600 mm² in one side)
 Copper (Cu) traces occupy 50% of the board area
 In top and back faces
 Package heat-sink is tied to the copper traces
 (Board of SOT-26 is used.)
- Material: Glass Epoxy (FR-4)
- Thickness: 1.6 mm
- Through-hole: 4 x 0.8 Diameter

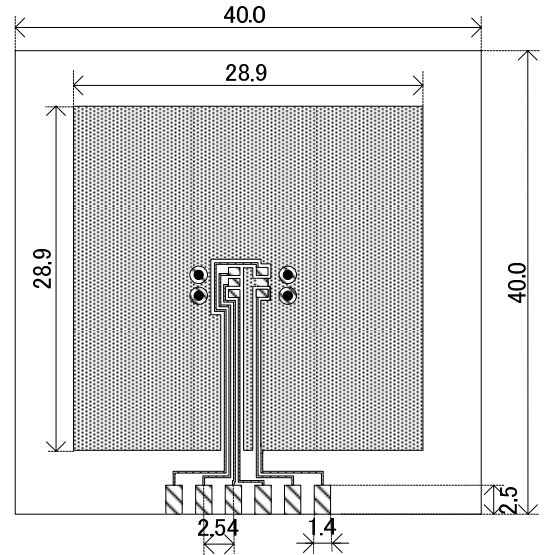

Evaluation Board (Unit: mm)

2. Power Dissipation vs. Ambient temperature

Board Mount ($T_j \text{ max} = 125^\circ\text{C}$)

Ambient Temperature ($^\circ\text{C}$)	Power Dissipation Pd (mW)	Thermal Resistance ($^\circ\text{C}/\text{W}$)
25	600	166.67
85	240	

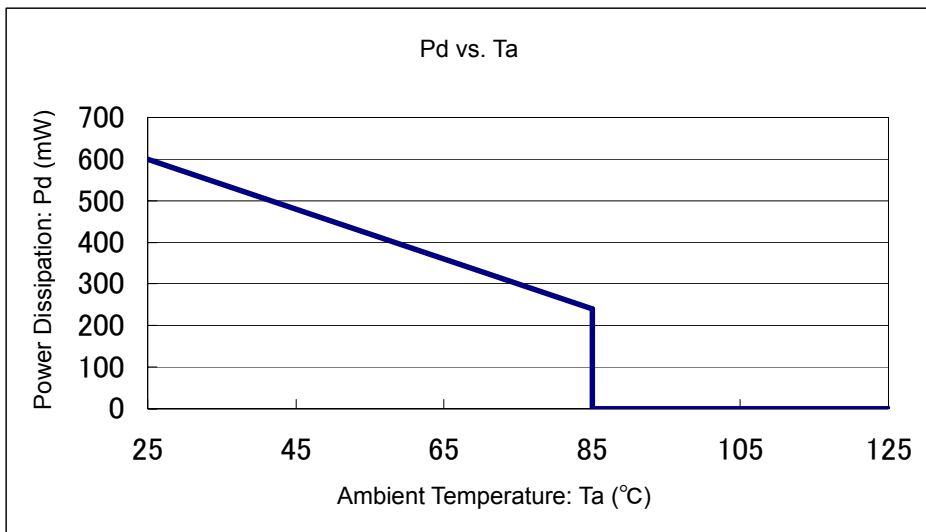

■ PACKAGING INFORMATION (Continued)

● SOT-89-5 Power Dissipation

Power dissipation data for the SOT-89-5 is shown in this page.
The value of power dissipation varies with the mount board conditions.
Please use this data as the reference data taken in the following condition.

1. Measurement Condition

- Condition: Mount on a board
- Ambient: Natural convection
- Soldering: Lead (Pb) free
- Board: Dimensions 40 x 40 mm (1600 mm² in one side)
Copper (Cu) traces occupy 50% of the board area
In top and back faces
Package heat-sink is tied to the copper traces
- Material: Glass Epoxy (FR-4)
- Thickness: 1.6 mm
- Through-hole: 5 x 0.8 Diameter

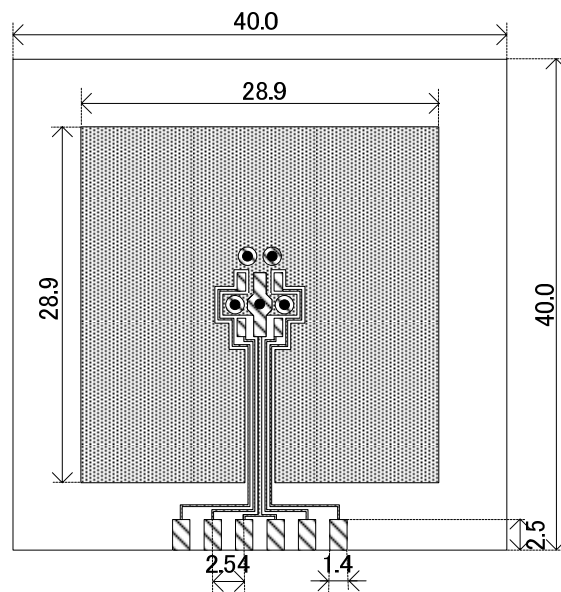

Evaluation Board (Unit: mm)

2. Power Dissipation vs. Ambient temperature

Board Mount ($T_j \text{ max} = 125^\circ\text{C}$)

Ambient Temperature ($^\circ\text{C}$)	Power Dissipation P_d (mW)	Thermal Resistance ($^\circ\text{C}/\text{W}$)
25	1300	76.92
85	520	

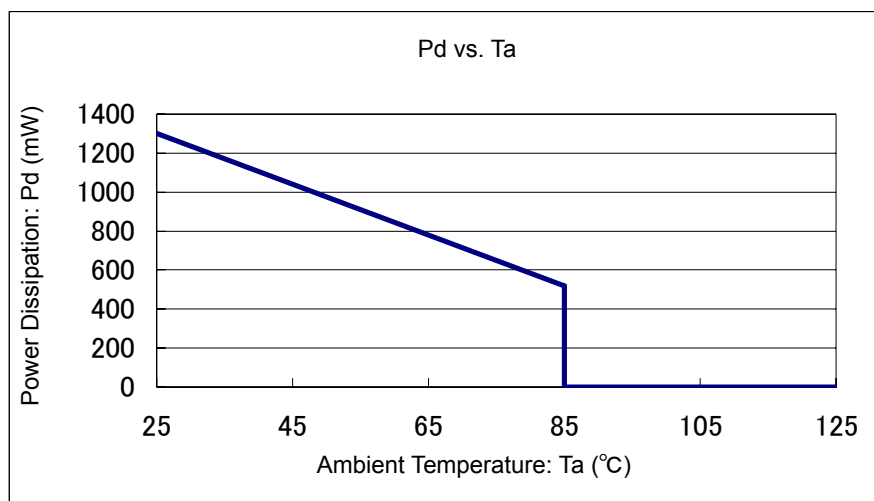

PACKAGING INFORMATION (Continued)

- WLP-5-02 Power Dissipation

Power dissipation data for the WLP-5-02 is shown in this page.
 The value of power dissipation varies with the mount board conditions.
 Please use this data as one of reference data taken in the described condition.

1. Measurement Conditions

- Condition : Mount on a board
- Ambient : Natural convection
- Soldering : Lead (Pb) free
- Board Dimensions : 40mm×40mm (1600mm² in one side)
- Metal Area : 1st Metal Layer about 50%
 2nd Inner Metal Layer about 50%
 3rd Inner Metal Layer about 50%
 4th Metal Layer about 50%
 4 separations is each layer connected to each pin
- Material : Glass Epoxy (FR-4)
- Thickness : 1.6mm
- Through-hole : 4 x 0.8 Diameter

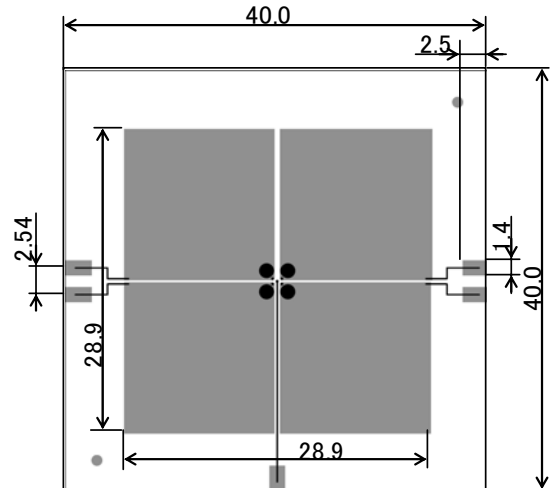

2. Power Dissipation vs. Ambient temperature

Board Mount (T_{jmax}=125°C)

Ambient Temperature (°C)	Power Dissipation Pd (mW)	Thermal Resistance (°C/W)
25	750	133.33
85	300	

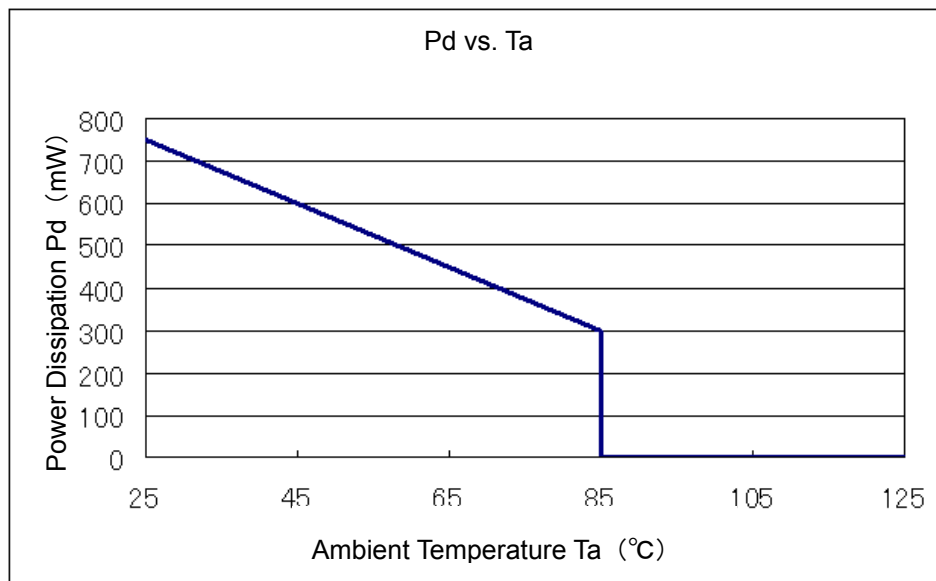

■ MARKING RULE

① represents product series

MARK	PRODUCT SERIES
P	XC6602A****-G
R	XC6602B****-G

② represents voltage range

MARK	OUTPUT VOLTAGE (V)	MARK	OUTPUT VOLTAGE (V)
A	0.5	N	1.5
B	0.6	P	1.6
C	0.7	R	1.7
D	0.8	S	1.8
E	0.9	T	-
F	1.0	U	-
H	1.1	V	-
K	1.2	X	-
L	1.3	Y	-
M	1.4	Z	-

③④ represents production lot number
01 to 09, 0A to 0Z, 11 to 9Z, A1 to A9, AA to Z9, B1 to ZZ in order.
(G, I, J, O, Q, W excluded)
*No character inversion used.

SOT-26W

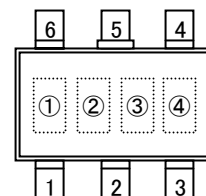

MARKING RULE (Continued)

① represents product series

MARK	PRODUCT SERIES
7	XC6602*****-G

② represents regulator type

MARK	PRODUCT SERIES
A	XC6602A****-G
B	XC6602B****-G

③ represents voltage range

MARK	OUTPUT VOLTAGE (V)	MARK	OUTPUT VOLTAGE (V)	MARK	OUTPUT VOLTAGE (V)
0	0.5	A	1.5	N	-
1	0.6	B	1.6	P	-
2	0.7	C	1.7	R	-
3	0.8	D	1.8	S	-
4	0.9	E	-	T	-
5	1.0	F	-	U	-
6	1.1	H	-	V	-
7	1.2	K	-	X	-
8	1.3	L	-	Y	-
9	1.4	M	-	Z	-

④⑤ represents production lot number

01 to 09, 0A to 0Z, 11 to 9Z, A1 to A9, AA to AZ, B1 to ZZ in order.
(G, I, J, O, Q, W excluded)

SOT-89-5

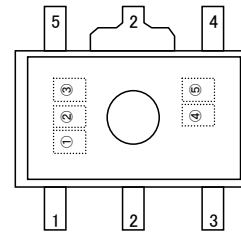

USP-6C

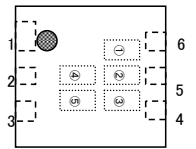

WLP-5-02

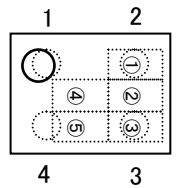

1. The products and product specifications contained herein are subject to change without notice to improve performance characteristics. Consult us, or our representatives before use, to confirm that the information in this datasheet is up to date.
2. We assume no responsibility for any infringement of patents, patent rights, or other rights arising from the use of any information and circuitry in this datasheet.
3. Please ensure suitable shipping controls (including fail-safe designs and aging protection) are in force for equipment employing products listed in this datasheet.
4. The products in this datasheet are not developed, designed, or approved for use with such equipment whose failure or malfunction can be reasonably expected to directly endanger the life of, or cause significant injury to, the user.
(e.g. Atomic energy; aerospace; transport; combustion and associated safety equipment thereof.)
5. Please use the products listed in this datasheet within the specified ranges.
Should you wish to use the products under conditions exceeding the specifications, please consult us or our representatives.
6. We assume no responsibility for damage or loss due to abnormal use.
7. All rights reserved. No part of this datasheet may be copied or reproduced without the prior permission of TOREX SEMICONDUCTOR LTD.

TOREX SEMICONDUCTOR LTD.