

ESD5374D

Low Capacitance Transient Voltage Suppressors Array

Descriptions

The ESD5374D is a low capacitance TVS (Transient Voltage Suppressor) array designed to protect high speed data interfaces. It incorporates 3 lines low capacitance TVS diodes and 1 line high surge capability TVS diode in one package, it is suitable to replace multiple discrete components in portable electronics.

The ESD5374D is specifically designed to protect USB port. 3 lines of low capacitance TVS diodes are used to protect USB data (DP, DM) and USB ID pins operating up to 5V. 1 line of TVS diode with higher surge capability of 90A (8/20µs) is used to protect USB voltage bus pin operating up to 12V.

The ESD5374D may be used to provide ESD protection up to ±20kV (DP, DM, ID Pins) and ±30kV (VBus Pin) according to IEC61000-4-2 contact discharge, and withstand peak pulse current up to 4A (DP, DM, ID Pins) and 90A (VBus Pin) according to IEC61000-4-5 (8/20µs).

The ESD5374D is available in DFN1.8×2.0-6L package. Standard products are Pb-free and Halogen-free.

Features

- Reverse stand-off voltage: 5V max. (DP, DM, ID Pins)
12V max. (VBus Pin)
- ESD protection according to IEC61000-4-2
Contact & Air discharge: ±20kV (DP, DM, ID Pins)
±30kV (VBus Pin)
- Surge protection according to IEC61000-4-5
8/20µs waveform: 4A (DP, DM, ID Pins)
90A (VBus Pin)
- Low capacitance: $C_j = 0.40\text{pF}$ typ. (DP, DM, ID Pins)
- Low clamping voltage
- Solid-state silicon technology

Applications

- USB 2.0
- USB OTG

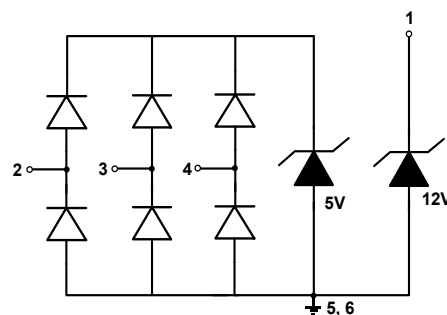

Circuit diagram

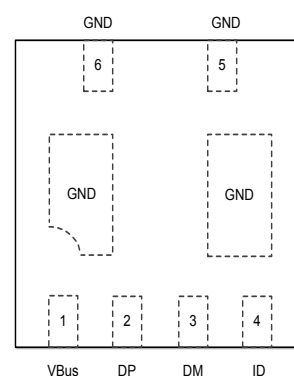

Pin configuration (Top View)

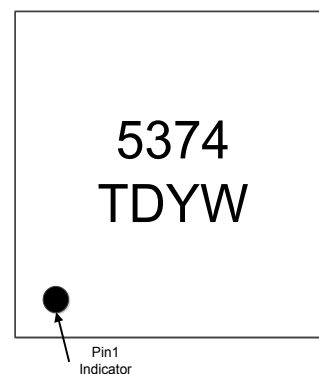

5374 = Device code
TD = Fixed code
YW = Date code

Marking

Order information

Device	Package	Shipping
ESD5374D-6/TR	DFN1.8×2.0-6L	3000/Tape&Reel

Absolute maximum ratings

ESD5374D

Parameter	Symbol	Rating	Unit
USB DP, DM, ID TVS			
Peak pulse power ($t_p = 8/20\mu s$)	P_{pk}	56	W
Peak pulse current ($t_p = 8/20\mu s$)	I_{pp}	4	A
ESD according to IEC61000-4-2 air discharge	V_{ESD}	± 20	kV
ESD according to IEC61000-4-2 contact discharge		± 20	
Operation junction temperature	T_J	125	$^{\circ}C$
Lead temperature	T_L	260	$^{\circ}C$
Storage temperature	T_{STG}	-55~150	$^{\circ}C$
VBus TVS			
Peak pulse power ($t_p = 8/20\mu s$)	P_{pk}	2700	W
Peak pulse current ($t_p = 8/20\mu s$)	I_{pp}	90	A
ESD according to IEC61000-4-2 air discharge	V_{ESD}	± 30	kV
ESD according to IEC61000-4-2 contact discharge		± 30	
Operation junction temperature	T_J	125	$^{\circ}C$
Lead temperature	T_L	260	$^{\circ}C$
Storage temperature	T_{STG}	-55~150	$^{\circ}C$

Electrical characteristics ($T_A = 25^{\circ}C$, unless otherwise noted)

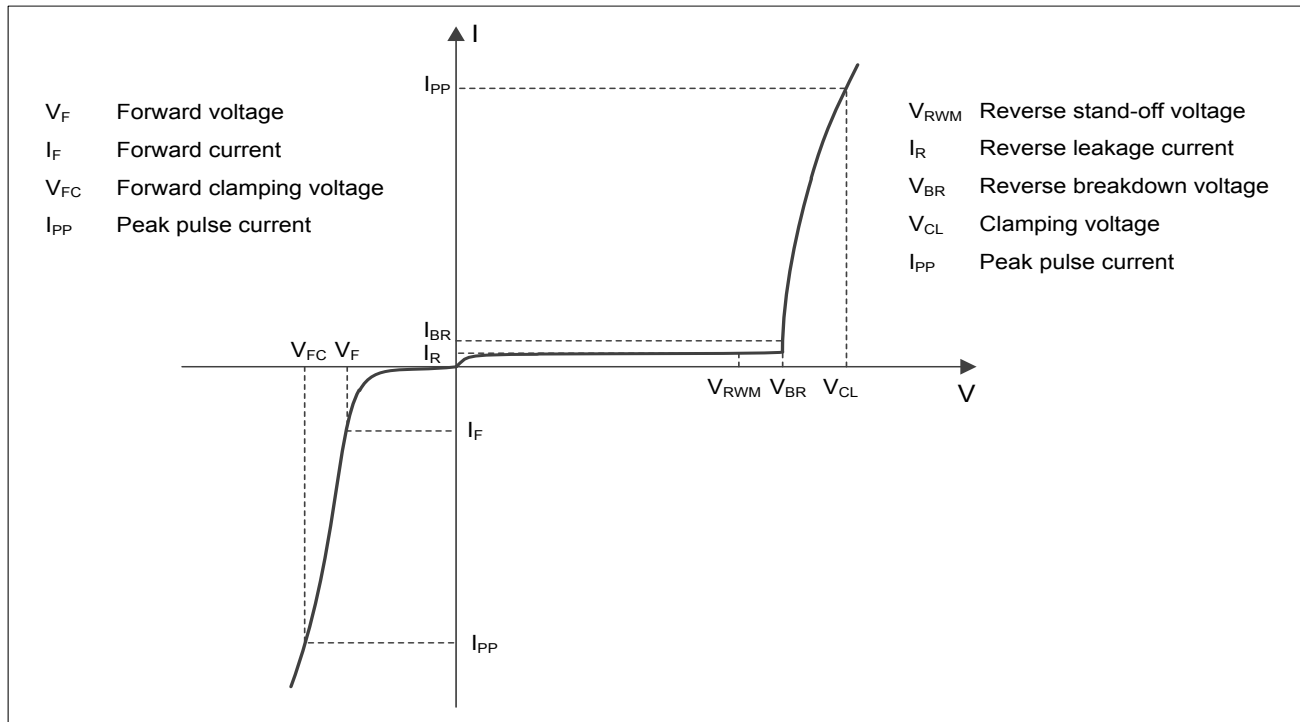

Definitions of electrical characteristics

Electrical characteristics (T_A = 25°C, unless otherwise noted)

Parameter	Symbol	Condition	Min.	Typ.	Max.	Unit
USB DP, DM, ID TVS						
Reverse stand-off voltage	V _{RWM}				5.0	V
Reverse leakage current	I _R	V _{RWM} = 5V		<1	100	nA
Reverse breakdown voltage	V _{BR}	I _{BR} = 1mA	7.0	8.0	9.0	V
Forward voltage	V _F	I _F = 10mA	0.6	0.9	1.2	V
Clamping voltage ¹⁾	V _{CL}	I _{PP} = 16A, t _p = 100ns		17.5		V
Clamping voltage ²⁾	V _{CL}	V _{ESD} = +8kV		17.5		V
Clamping voltage ³⁾	V _{CL}	I _{PP} = 1A, t _p = 8/20μs			11	V
		I _{PP} = 4A, t _p = 8/20μs			14	V
Dynamic resistance ¹⁾	R _{DYN}			0.55		Ω
Junction capacitance	C _J	V _R = 0V, f = 1MHz, Pin2, 3, 4 to GND		0.40	0.65	pF
		V _R = 0V, f = 1MHz, Between Pin2, 3, 4		0.25	0.40	pF
VBus TVS						
Reverse stand-off voltage	V _{RWM}				12	V
Reverse leakage current	I _R	V _{RWM} = 12V			500	nA
Reverse breakdown voltage	V _{BR}	I _{BR} = 1mA	13.5	15.0	16.5	V
Forward voltage	V _F	I _F = 10mA	0.4	0.7	1.0	V
Clamping voltage ³⁾	V _{CL}	I _{PP} = 30A, t _p = 8/20μs			22	V
		I _{PP} = 90A, t _p = 8/20μs			30	V
Junction capacitance	C _J	V _R = 0V, f = 1MHz, Pin1 to GND		800	1200	pF

Notes:

- 1) TLP parameter: Z₀ = 50Ω, t_p = 100ns, t_r = 2ns, averaging window from 60ns to 80ns. R_{DYN} is calculated from 4A to 16A.
- 2) Contact discharge mode, according to IEC61000-4-2.
- 3) Non-repetitive current pulse, according to IEC61000-4-5.

Typical characteristics ($T_A = 25^\circ\text{C}$, unless otherwise noted)

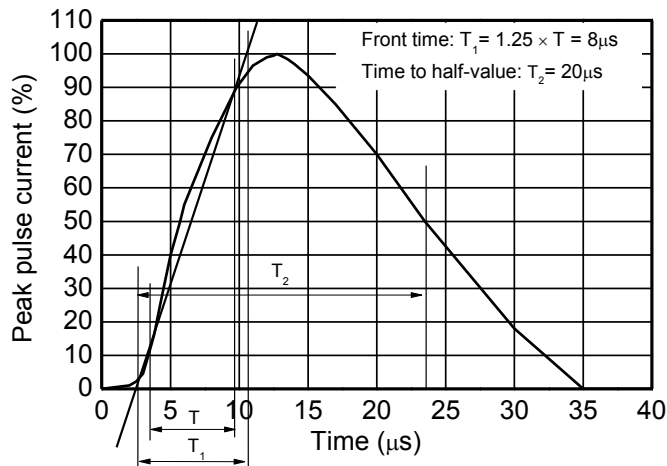

8/20 μs waveform per IEC61000-4-5

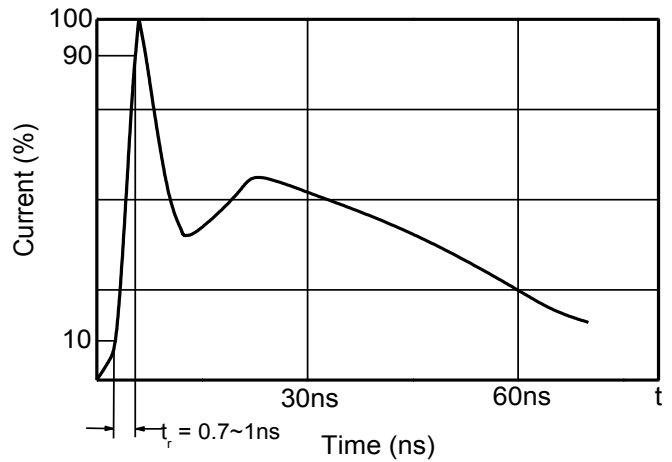

Contact discharge current waveform per IEC61000-4-2

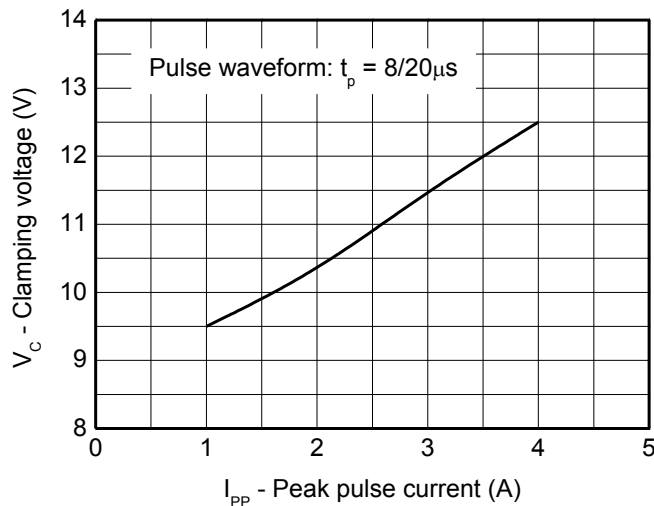

Clamping voltage vs. Peak pulse current
(DP, DM, ID Pins)

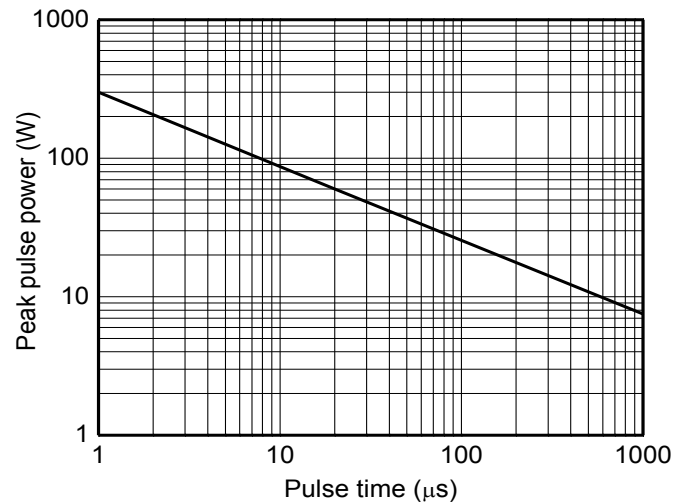

Non-repetitive peak pulse power vs. Pulse time
(DP, DM, ID Pins)

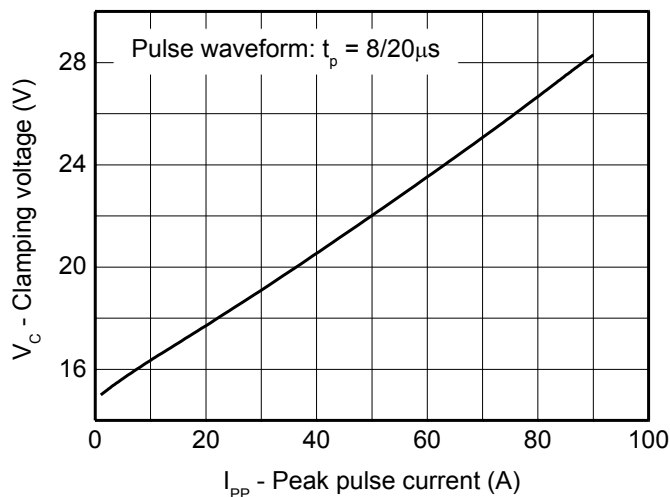

Clamping voltage vs. Peak pulse current
(VBus Pin)

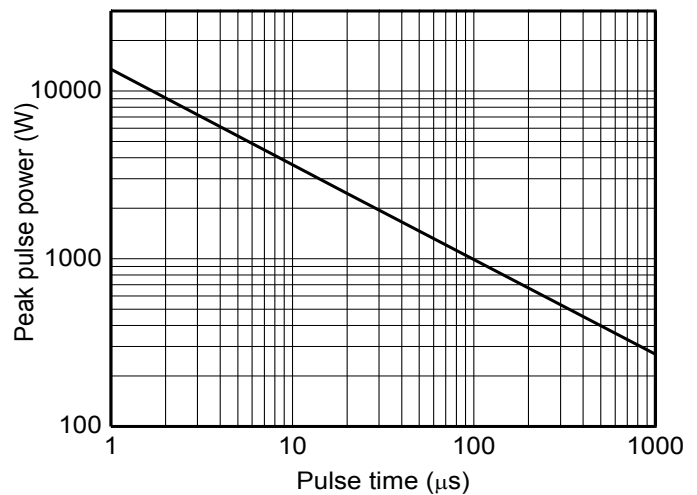

Non-repetitive peak pulse power vs. Pulse time
(VBus Pin)

ESD5374D

Typical characteristics ($T_A = 25^\circ\text{C}$, unless otherwise noted)

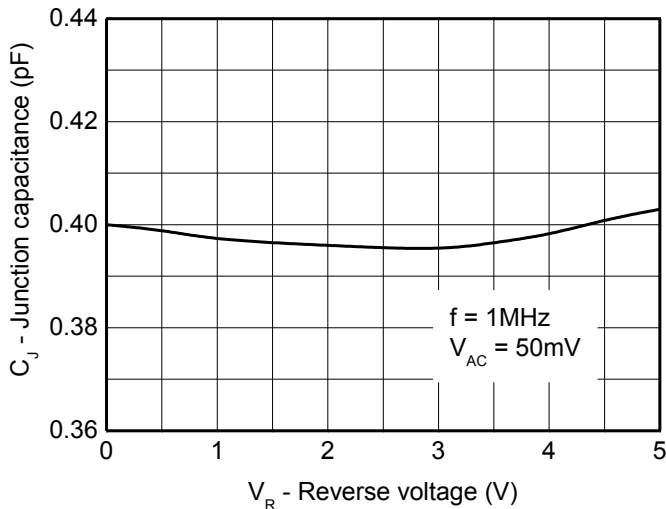

Capacitance vs. Reverse voltage
(DP, DM, ID Pins)

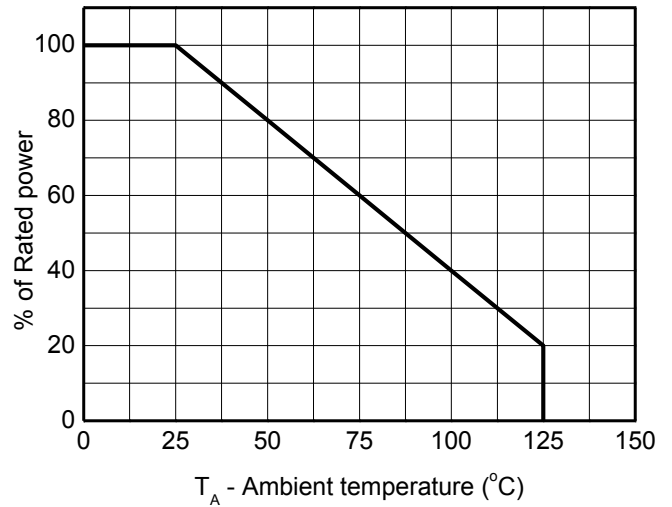

Power derating vs. Ambient temperature

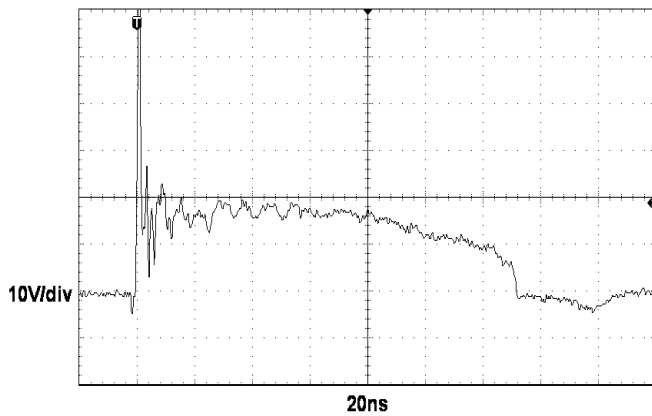

ESD clamping +8kV contact discharge
(DP, DM, ID Pins)

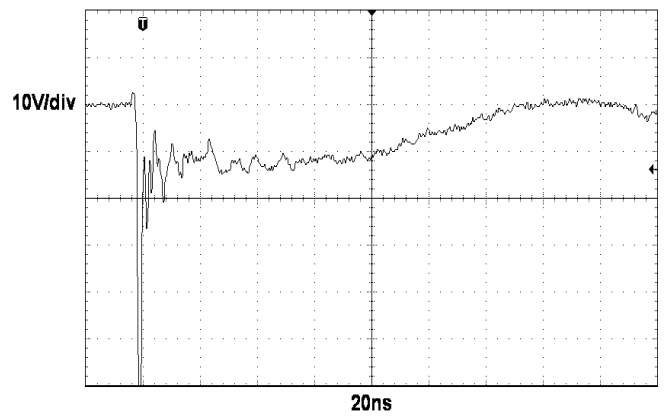

ESD clamping -8kV contact discharge
(DP, DM, ID Pins)

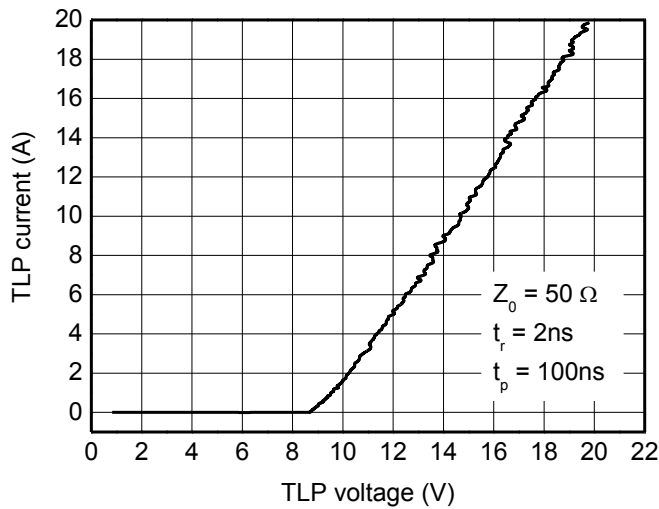

TLP Measurement
(DP, DM, ID Pins)

Package outline dimensions

DFN1.8x2.0-6L

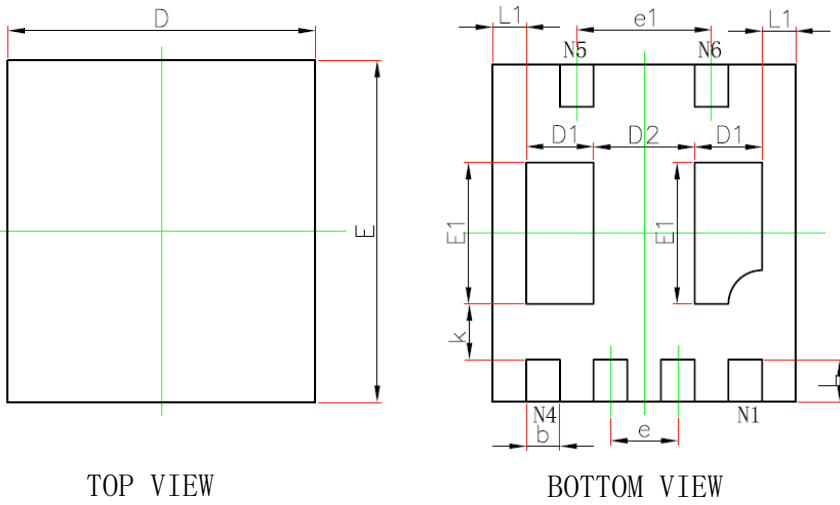

TOP VIEW

BOTTOM VIEW

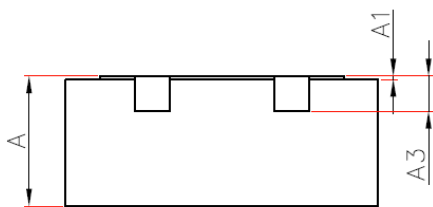

SIDE VIEW

Symbol	Dimensions In Millimeters		
	Min.	Typ.	Max.
A	0.700	0.750	0.800
A1	0.000	--	0.050
A3	0.203 REF.		
D	1.700	1.800	1.900
E	1.900	2.000	2.100
D1	0.300	0.400	0.500
E1	0.740	0.840	0.940
D2	0.550	0.600	0.650
b	0.150	0.200	0.250
e	0.400 TYP.		
e1	0.800 TYP.		
k	0.200 MIN.		
L	0.174	0.250	0.326
L1	0.150	0.200	0.250

Recommended land pattern (Unit: mm)

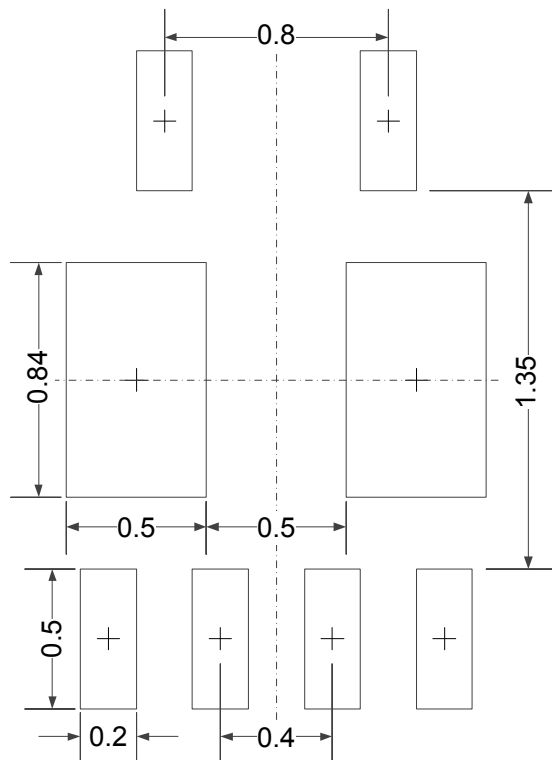

Notes:

This recommended land pattern is for reference purposes only. Please consult your manufacturing group to ensure your PCB design guidelines are met.