

Cree® XLamp® MK-R2 LEDs

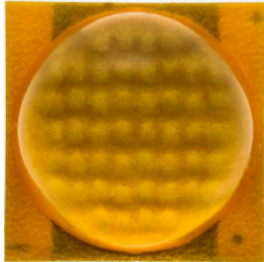

PRODUCT DESCRIPTION

The XLamp MK-R2 EasyWhite LED builds on the breakthrough performance of the original MK-R by enabling high-voltage driver solutions while providing a small, uniform, single point source for precise optical control. The MK-R2 shares the same mechanical footprint as the original MK-R, providing customers with a seamless upgrade path and shortening the LED luminaire and retrofit lamp design cycle.

MK-R2 LEDs are designed for high-output, directional lighting applications and are the ideal replacement for lighting applications that currently use inefficient halogen lamps. MK-R2 LEDs are optimized for use in track, accent, lamp retrofit, downlighting and other applications where color quality, consistency and optical control are required.

FEATURES

- Available in 4-step and 2-step EasyWhite® bins at 3000 K, 80-CRI minimum
- Maximum drive current: 420 mA
- Low thermal resistance: 1.7 °C/W
- Maximum junction temperature: 150 °C
- Binned at 85 °C
- Viewing angle: 120°
- Unlimited floor life at ≤ 30 °C/85% RH
- Reflow solderable - JEDEC J-STD-020C
- Electrically neutral thermal path
- RoHS-compliant
- UL-recognized component (E349212)



TABLE OF CONTENTS

Characteristics	2
Flux Characteristics, Standard	
Order Codes and Bins	2
Relative Spectral Power	
Distribution.....	3
Relative Flux vs. Junction	
Temperature	3
Electrical Characteristics.....	4
Relative Flux vs. Current	4
Relative Chromaticity vs. Current -	
Warm White.....	5
Relative Chromaticity vs.	
Temperature - Warm White	5
Typical Spatial Distribution.....	6
Thermal Design.....	6
Performance Groups - Brightness.	7
Performance Groups -	
Chromaticity	7
Cree EasyWhite Bins Plotted on	
the 1931 CIE Color Space.....	8
Bin and Order Code Formats	8
Reflow Soldering Characteristics ..	9
Notes.....	10
Mechanical Dimensions.....	11
Tape and Reel	12
Packaging.....	13

CHARACTERISTICS

Characteristics	Unit	Minimum	Typical	Maximum
Thermal resistance, junction to solder point	°C/W		1.7	
Viewing angle - full width half maximum (FWHM)	degrees		120	
Temperature coefficient of voltage	mV/°C		-28	
ESD withstand voltage (HBM per Mil-Std-883D)	V			8000
DC forward current	mA			420
Reverse current	mA			100
Forward voltage (@ 233 mA, 85 °C)	V		36	
Forward voltage (@ 233 mA, 25 °C)	V			42
LED junction temperature	°C			150

FLUX CHARACTERISTICS, STANDARD ORDER CODES AND BINS ($I_f = 233 \text{ mA}$, $T_j = 85 \text{ °C}$)

The following tables provide order codes for XLamp MK-R2 EasyWhite LEDs. For a complete description of the order code nomenclature, please reference Bin and Order Code Formats (page 8).

Color	CCT Range	Base Order Codes Min. Luminous Flux @ 233 mA			2-Step Order Code		4-Step Order Code	
		Group	Flux (lm) @ 85 °C	Flux (lm) @ 25 °C*	Chromaticity Region		Chromaticity Region	
80-CRI EasyWhite	3000 K	G4	840	961	30H	MKRBWT-00-0000-0N0HG430H	30F	MKRBWT-00-0000-0N0HG430F
		G2	780	893		MKRBWT-00-0000-0N0HG230H		MKRBWT-00-0000-0N0HG230F

Notes:

- Cree maintains a tolerance of $\pm 7\%$ on flux and power measurements, ± 0.005 on chromaticity (CCx, CCy) measurements and ± 2 on CRI measurements.
- Minimum CRI for 80-CRI White is 80.
- * Flux values @ 25 °C are calculated and for reference only.

RELATIVE SPECTRAL POWER DISTRIBUTION

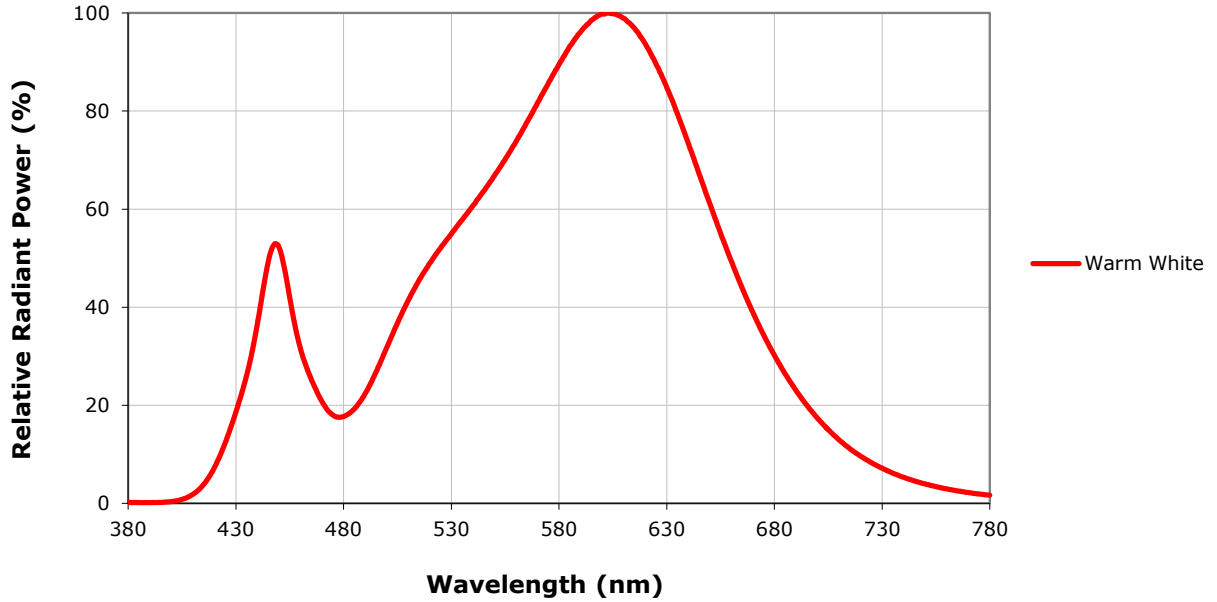

RELATIVE FLUX VS. JUNCTION TEMPERATURE ($I_f = 233 \text{ mA}$)

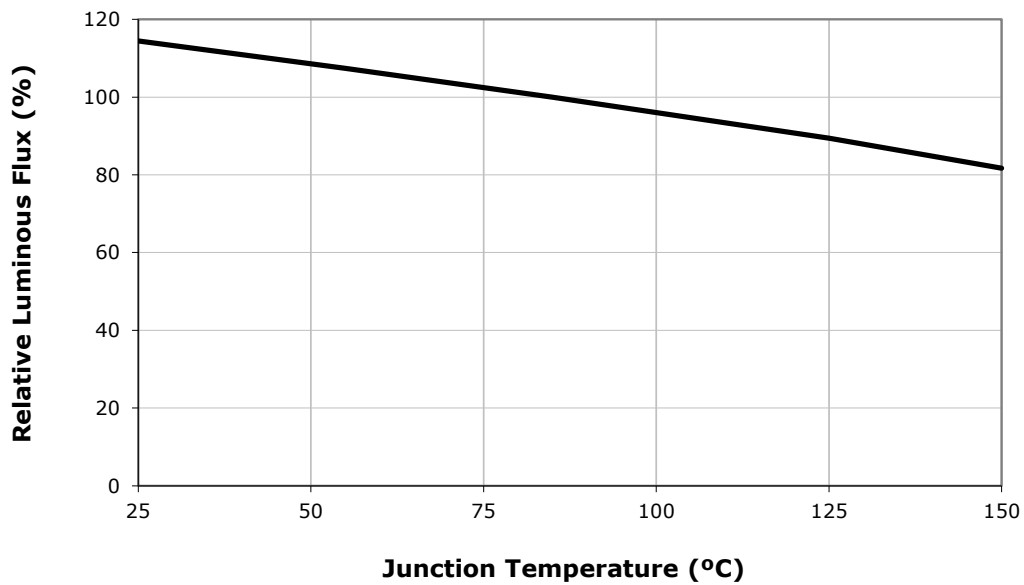

ELECTRICAL CHARACTERISTICS ($T_j = 85\text{ }^\circ\text{C}$)

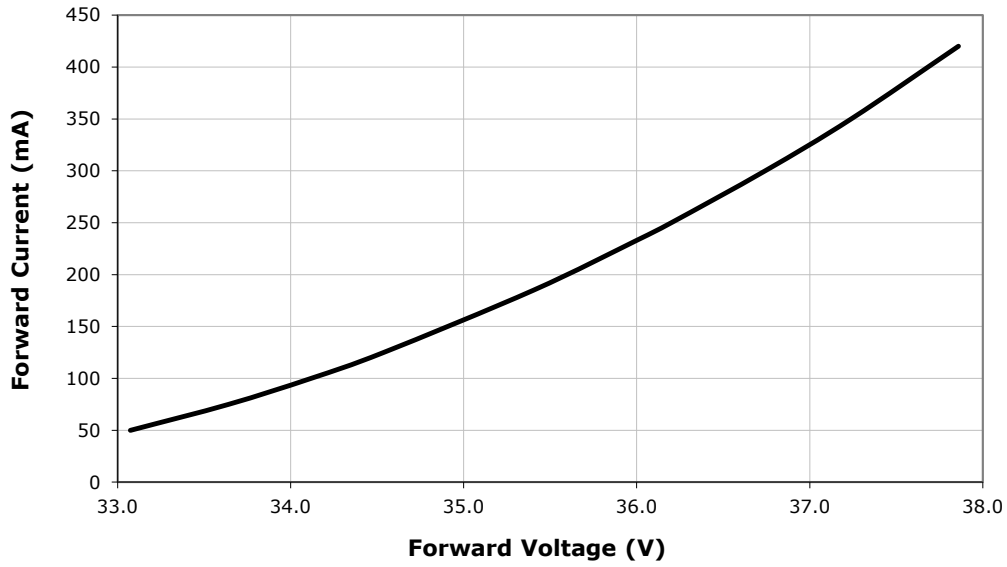

RELATIVE FLUX VS. CURRENT ($T_j = 85\text{ }^\circ\text{C}$)

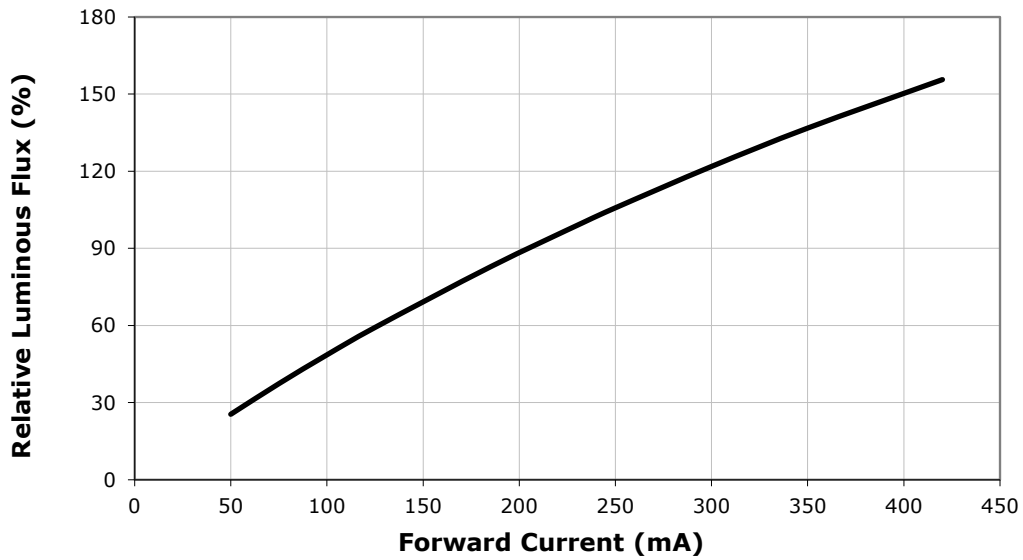

RELATIVE CHROMATICITY VS. CURRENT - WARM WHITE ($T_j = 85\text{ }^\circ\text{C}$)

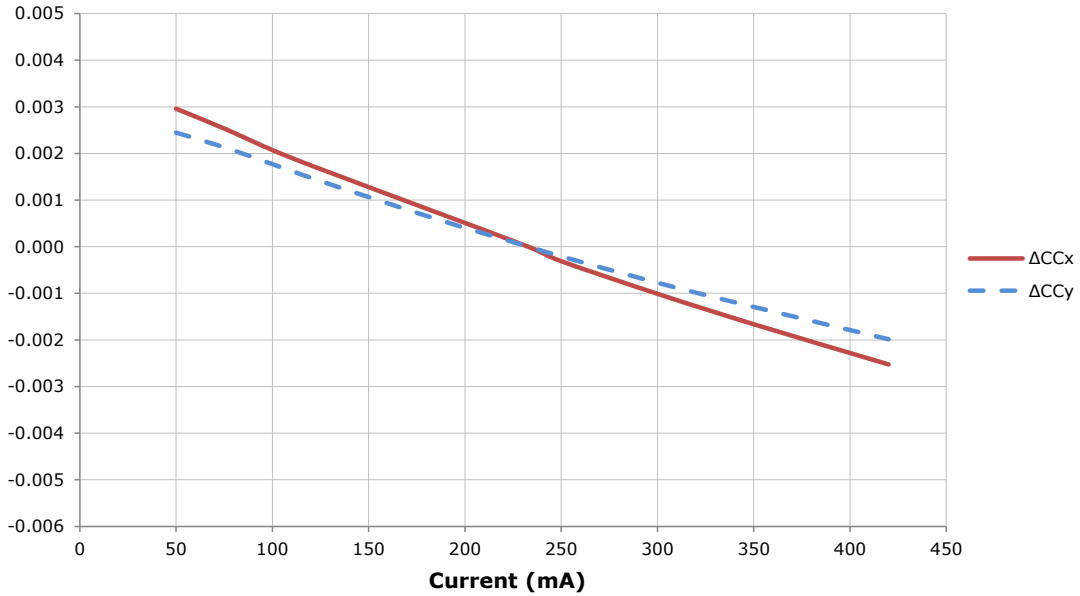

RELATIVE CHROMATICITY VS. TEMPERATURE - WARM WHITE ($I_f = 233\text{ mA}$)

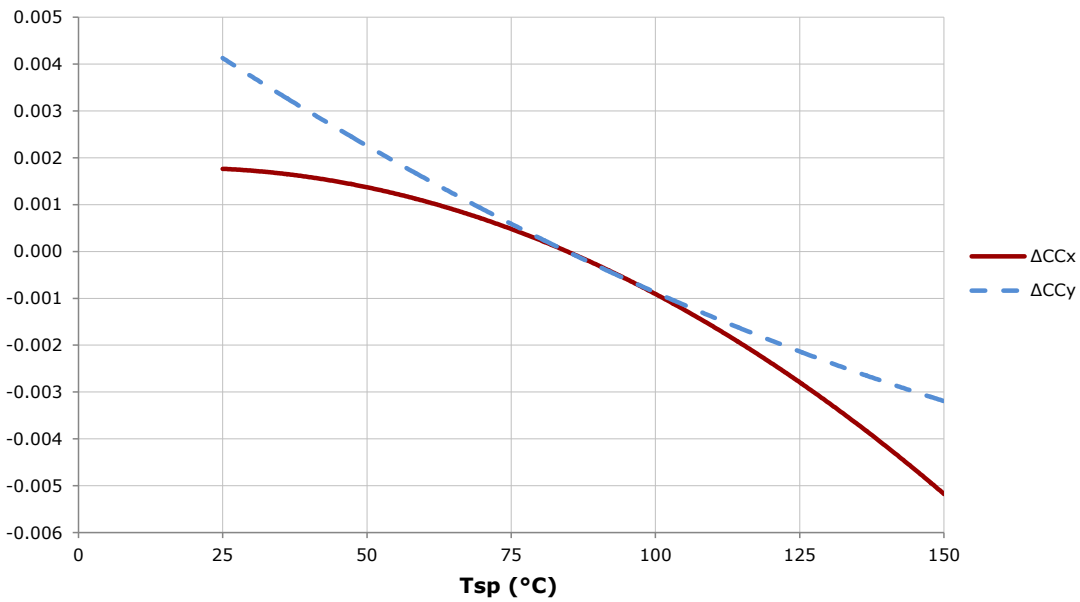

TYPICAL SPATIAL DISTRIBUTION

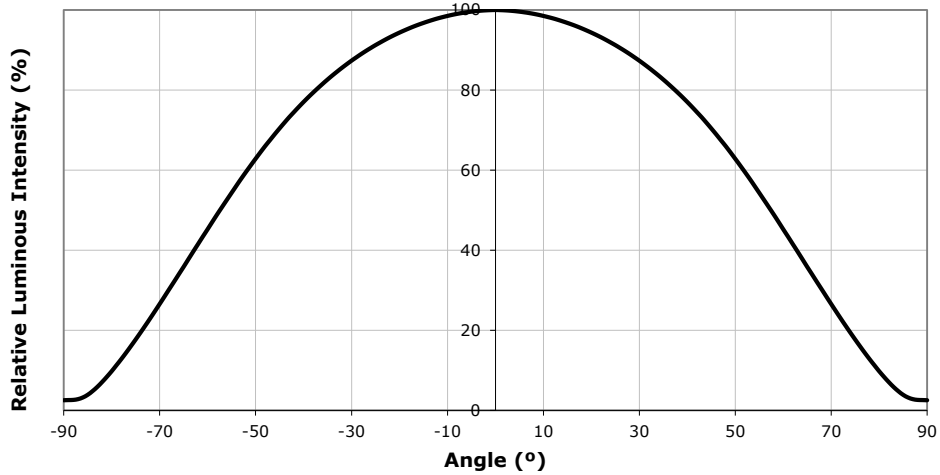

THERMAL DESIGN

The maximum forward current is determined by the thermal resistance between the LED junction and ambient. It is crucial for the end product to be designed in a manner that minimizes the thermal resistance from the solder point to ambient in order to optimize lamp life and optical characteristics.

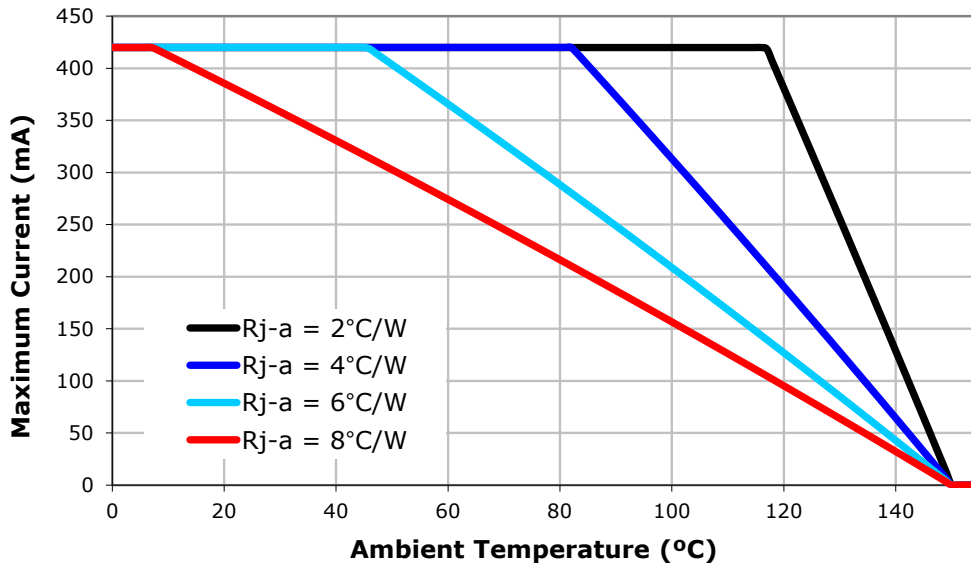

PERFORMANCE GROUPS - BRIGHTNESS ($I_f = 233 \text{ mA}$, $T_j = 85 \text{ }^\circ\text{C}$)

XLamp MK-R2 LEDs are tested for luminous flux and placed into one of the following bins.

Group Code	Min. Luminous Flux @ 233 mA	Max. Luminous Flux @ 233 mA
D2	510	550
D4	550	590
E2	590	635
E4	635	680
F2	680	730
F4	730	780
G2	780	840
G4	840	900
H2	900	970
H4	970	1040
J2	1040	1120
J4	1120	1200
K2	1200	1290

PERFORMANCE GROUPS - CHROMATICITY ($T_j = 85 \text{ }^\circ\text{C}$)

XLamp MK-R2 LEDs are tested for chromaticity and placed into one of the regions defined by the following bounding coordinates.

Code	CCT	x	y
30F	3000 K	0.4242	0.3919
		0.4322	0.4096
		0.4449	0.4141
		0.4359	0.3960

Code	CCT	x	y
30H	3000 K	0.4291	0.3973
		0.4333	0.4062
		0.4395	0.4084
		0.4351	0.3994

CREE EASYWHITE BINS PLOTTED ON THE 1931 CIE COLOR SPACE ($T_j = 85^\circ\text{C}$)

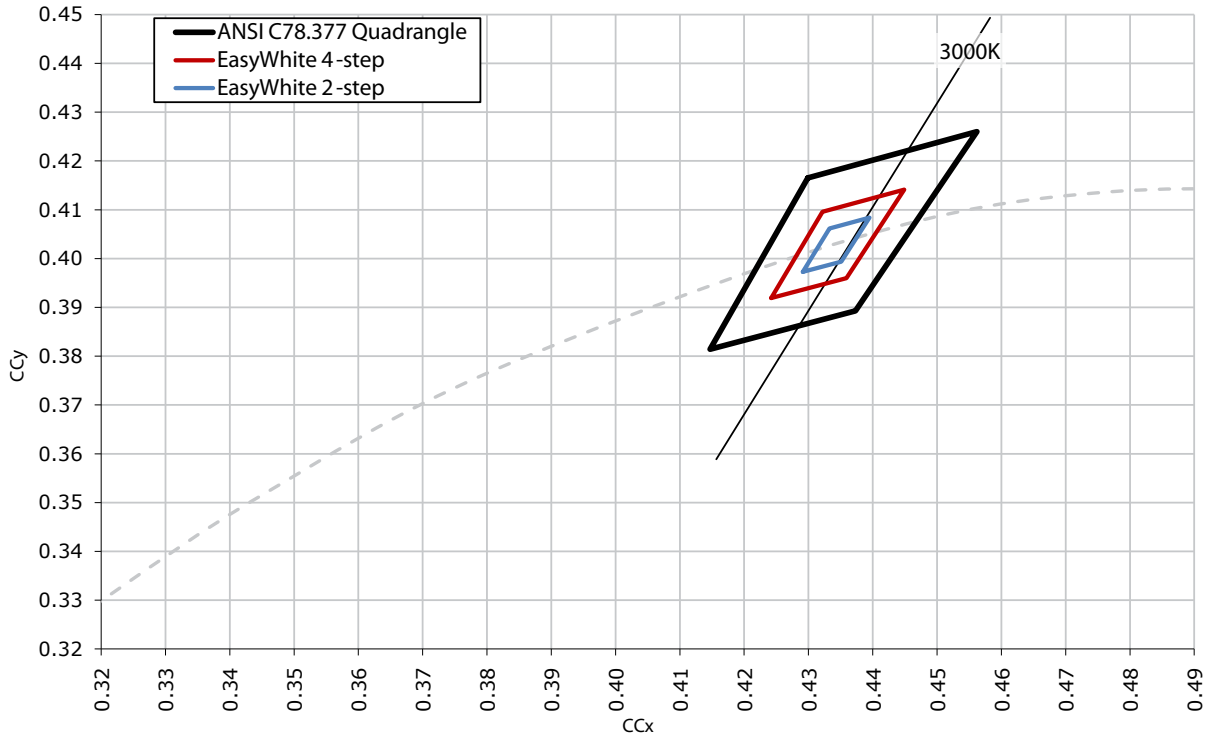

BIN AND ORDER CODE FORMATS

Bin codes and order codes are configured as follows.

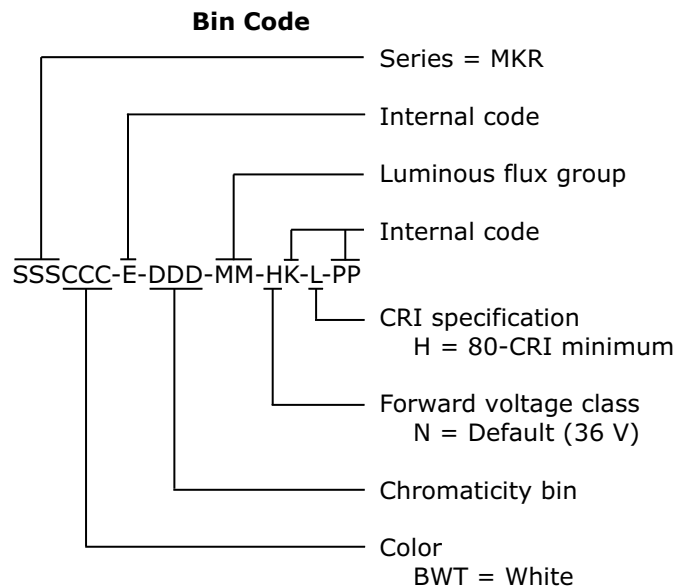
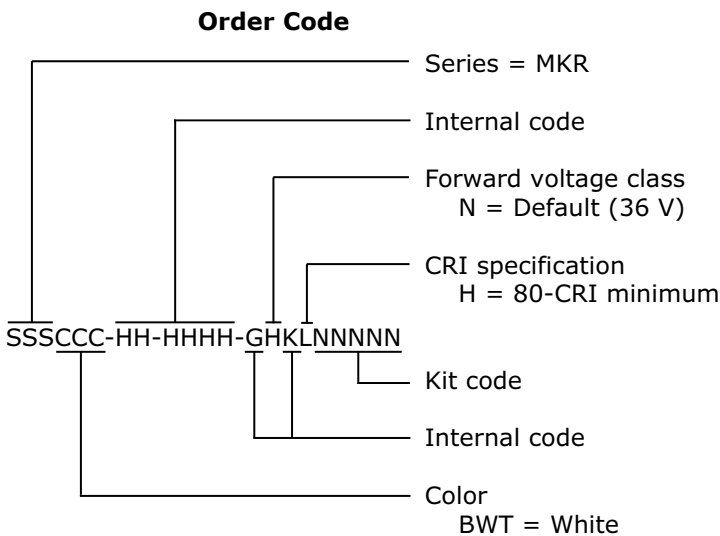

REFLOW SOLDERING CHARACTERISTICS

In testing, Cree has found XLamp MK-R2 LEDs to be compatible with JEDEC J-STD-020C, using the parameters listed below. As a general guideline, Cree recommends that users follow the recommended soldering profile provided by the manufacturer of solder paste used.

Note that this general guideline may not apply to all PCB designs and configurations of reflow soldering equipment.

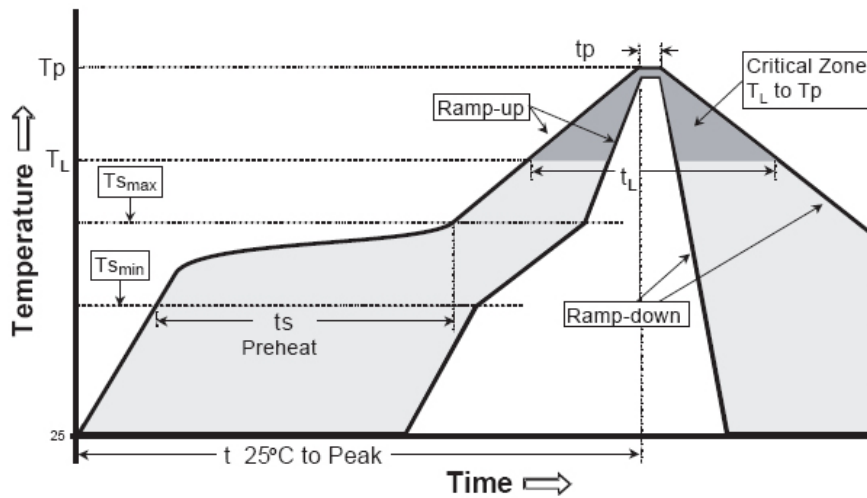

IPC/JEDEC J-STD-020C

Profile Feature	Lead-Based Solder	Lead-Free Solder
Average Ramp-Up Rate ($T_{s_{max}}$ to T_p)	3 °C/second max.	3 °C/second max.
Preheat: Temperature Min ($T_{s_{min}}$)	100 °C	150 °C
Preheat: Temperature Max ($T_{s_{max}}$)	150 °C	200 °C
Preheat: Time ($t_{s_{min}}$ to $t_{s_{max}}$)	60-120 seconds	60-180 seconds
Time Maintained Above: Temperature (T_l)	183 °C	217 °C
Time Maintained Above: Time (t_l)	60-150 seconds	60-150 seconds
Peak/Classification Temperature (T_p)	215 °C	260 °C
Time Within 5 °C of Actual Peak Temperature (t_p)	10-30 seconds	20-40 seconds
Ramp-Down Rate	6 °C/second max.	6 °C/second max.
Time 25 °C to Peak Temperature	6 minutes max.	8 minutes max.

Note: All temperatures refer to the topside of the package, measured on the package body surface.

NOTES

Lumen Maintenance Projections

Cree now uses standardized IES LM-80-08 and TM-21-11 methods for collecting long-term data and extrapolating LED lumen maintenance. For information on the specific LM-80 data sets available for this LED, refer to the public LM-80 results document at www.cree.com/xlamp_app_notes/LM80_results.

Please read the XLamp Long-Term Lumen Maintenance application note at www.cree.com/xlamp_app_notes/lumen_maintenance for more details on Cree's lumen maintenance testing and forecasting. Please read the XLamp Thermal Management application note at www.cree.com/xlamp_app_notes/thermal_management for details on how thermal design, ambient temperature, and drive current affect the LED junction temperature.

Moisture Sensitivity

In testing, Cree has found XLamp MK-R2 LEDs to have unlimited floor life in conditions ≤ 30 °C/85% relative humidity (RH). Moisture testing included a 168-hour soak at 85 °C/85% RH followed by 3 reflow cycles, with visual and electrical inspections at each stage.

Cree recommends keeping XLamp LEDs in their sealed moisture-barrier packaging until immediately prior to use. Cree also recommends returning any unused LEDs to the resealable moisture-barrier bag and closing the bag immediately after use.

RoHS Compliance

The levels of RoHS restricted materials in this product are below the maximum concentration values (also referred to as the threshold limits) permitted for such substances, or are used in an exempted application, in accordance with EU Directive 2011/65/EC (RoHS2), as implemented January 2, 2013. RoHS Declarations for this product can be obtained from your Cree representative or from the Product Documentation sections of www.cree.com.

UL Recognized Component

Level 4 enclosure consideration. The LED package or a portion thereof has been investigated as a fire and electrical enclosure per ANSI/UL 8750.

Vision Advisory Claim

WARNING: Do not look at exposed lamp in operation. Eye injury can result. See the Eye Safety application note at www.cree.com/xlamp_app_notes/led_eye_safety.

MECHANICAL DIMENSIONS

All measurements are $\pm .13$ mm unless otherwise indicated.

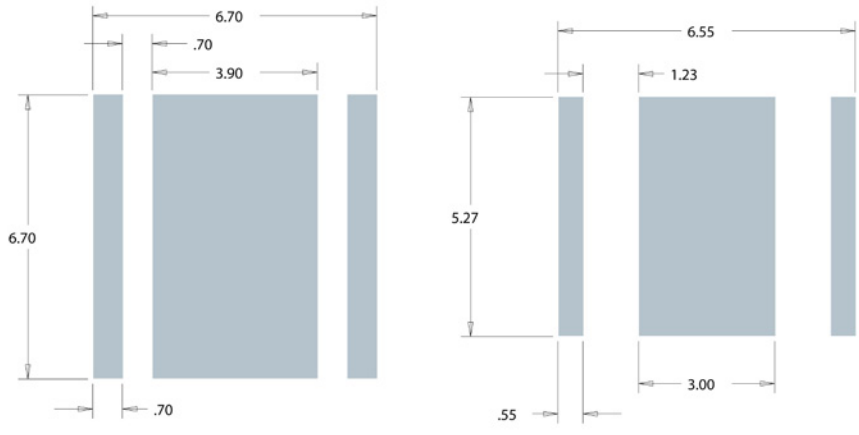
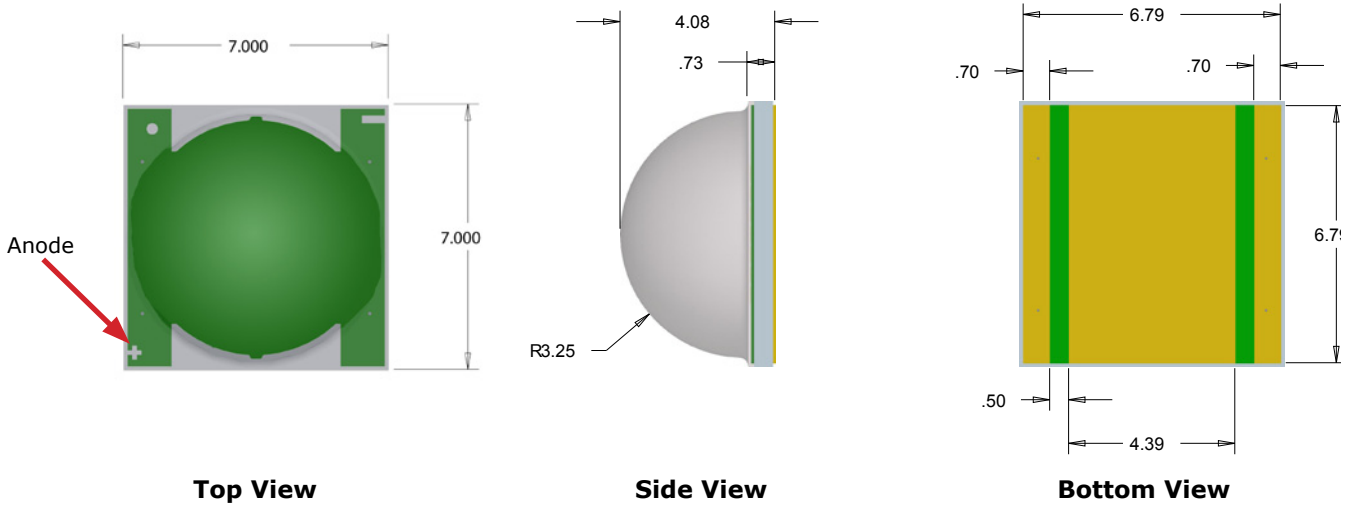

Recommended PCB Solder Pad

**Recommended Stencil Pattern
(Shaded Area Is Open)**

TAPE AND REEL

All Cree carrier tapes conform to EIA-481D, Automated Component Handling Systems Standard.

All dimensions in mm.

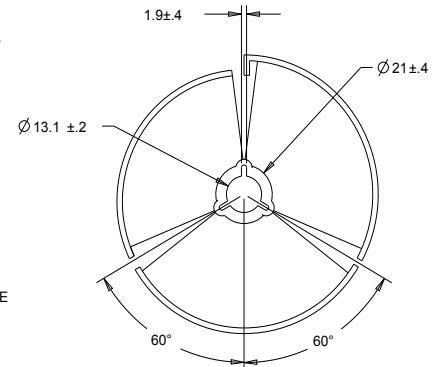
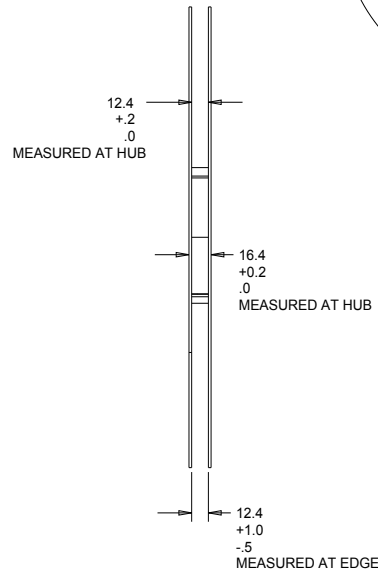
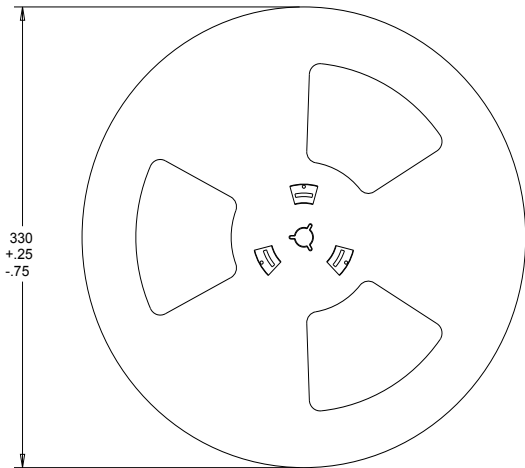
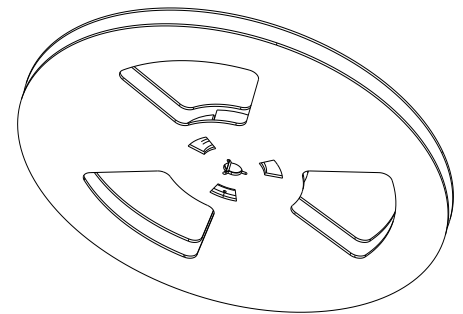
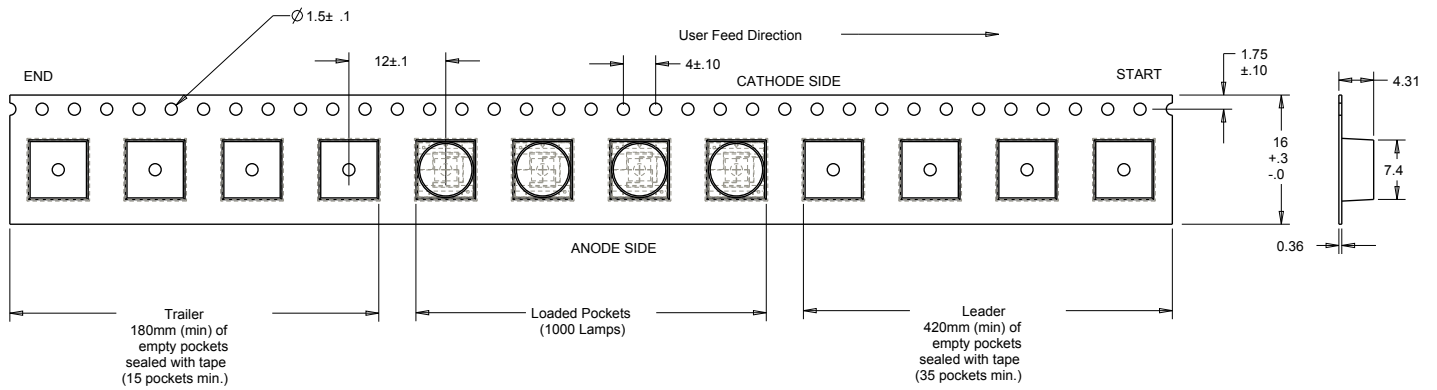

PACKAGING

Unpackaged Reel

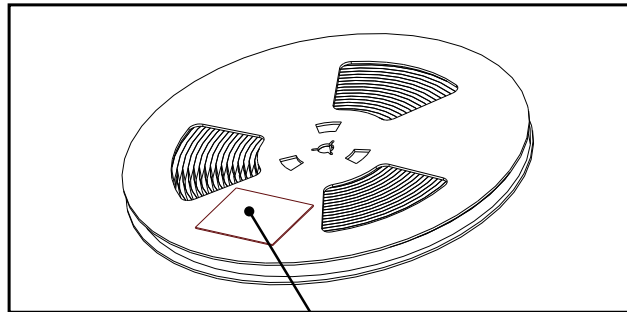

Label with Cree Bin Code, Qty, Reel ID

Packaged Reel

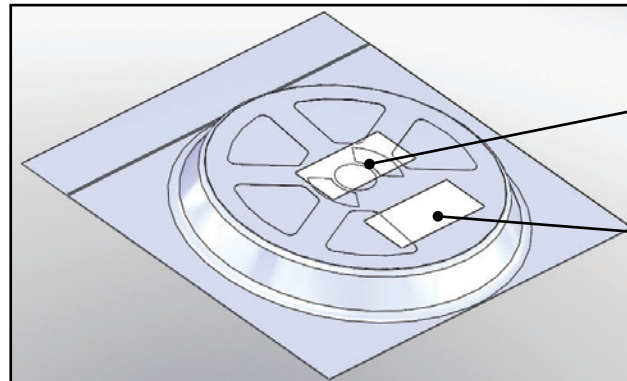

Label with Cree Order Code, Qty, Reel ID, PO #

Label with Cree Bin Code, Qty, Reel ID

Boxed Reel

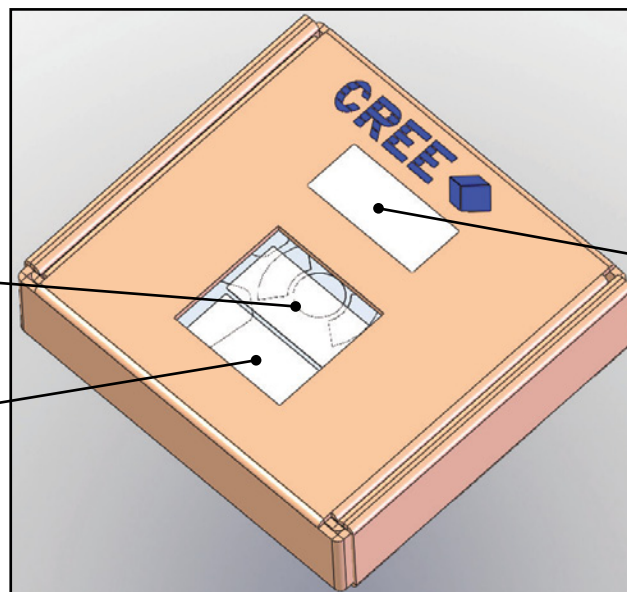

Label with Cree Order Code, Qty, Reel ID, PO #

Label with Cree Bin Code, Qty, Reel ID

Patent Label