

2A(4Arms)MOLD THYRISTOR C106Q,Y,F,A,B,C,D,E,M

The C106Q ~ C106M are P-gate all diffused mold type SCR granted average on-state current 2Amps ($T_c = 54^\circ\text{C}$). Being applied glassivation technique to pellets' surface, they feature a quite high reliability.

FEATURES

- The pellet surface is quite stable physically and electrically by applying glassivation technique.
- Easy installation by its miniature size and thin electrode leads.
- Less holding current distribution provides free application design.
- Low cost because of mass-production.

APPLICATIONS

MOTOR CONTROL	Electric Model Trains Sewing Machines Movie Projectors Food Mixers Electric Fans Slot Racing Cars	REMOTE CONTROL	Armchair TV Control Master Switching Stations for Home Garage Door Openers Power Switch
LIGHT	Flame Detectors Moving-Light Signs (Chasers) Driver for Computer Readout Lights Harbor Buoy Flashers Automotive Warning Systems Nixie & Neon Drivers	DRYNESS	Clothes Dryness Sensor
TEMPERATURE	Range Surface Unit (Hybrid) Chemical Processing (Photographic, etc.) Food Warmer Tray Bearing Temperature Sensor Electric Blanket Control	PROXIMITY	Burglar Alarm Touch Switch Electric Door Openers
PRESSURE	Auto Oil Pressure Gage Hot Water Boiler Safety Monitor	COUNTING	Low Speed Ring Counters Shift Registers
TIME	Photo Darkroom Exposure Oven Timer Vending Machine Logic Industrial Process Control	SWITCHING	Relay Replacement Solenoid Drivers Latching Relay Replacement Power Flip Flops Low Power Inverters Thyratron Tube Replacement
LIQUID LEVEL	Basement Sump Pump Automatic Coffee Maker Automatic Shutoff for Vending Machines	AMPLIFIERS	Gate Amplifier for Larger SCR's, Triacs -Blenders -Hand Tools
		IGNITION	Small Gas Engines Gas Appliances
		DETECTION	Voltage (Battery Charger) Current (Crowbar)

Outline Drawing (Unit: mm)

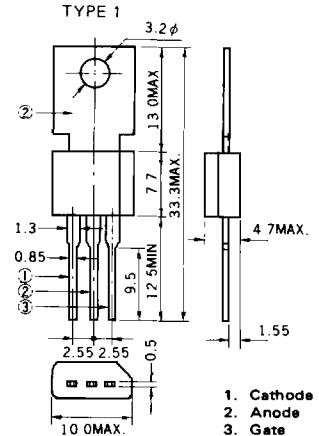

MAXIMUM RATINGS

Type	Repetitive Peak Reverse Voltage	Repetitive Peak Off-state Voltage
	V_{RRM}	V_{DRM} $R_{GK} = 1k\Omega$
C106Q	15 Volts	15 Volts
C106Y	30 Volts	30 Volts
C106F	50 Volts	50 Volts
C106A	100 Volts	100 Volts
C106B	200 Volts	200 Volts
C106C	300 Volts	300 Volts
C106D	400 Volts	400 Volts
C106E	500 Volts	500 Volts
C106M	600 Volts	600 Volts

Item	Symbol	Maximum Ratings	Units	Note
On-state Current	$I_T(AV)$	2 ($T_C = 54^\circ C, \theta = 180^\circ$ Single phase 1/2 wave)	A	
	$I_T(RMS)$	4		
Rise of Forward Current	di/dt	50 (non-repetitive)	A/ μs	
Surge On-state Current	I_{TSM}	20 (non-repetitive)	A	
Gate Power Dissipation	P_{GM}	0.5 ($f \geq 50$ Hz, duty $\geq 10\%$)	W	
Gate Power Dissipation	$P_G(AV)$	0.1	W	
Gate Forward Current	I_{FGM}	0.2 ($f \geq 50$ Hz, duty $\geq 10\%$)	A	
Gate Reverse Voltage	V_{RGM}	6	V	
Junction Temperature	T_j	-40 ~ + 110	$^\circ C$	
Storage Temperature	T_{sg}	-40 ~ + 150	$^\circ C$	
Weight		1.4	g	

EXAMPLE OF R_{GK} INSERTION

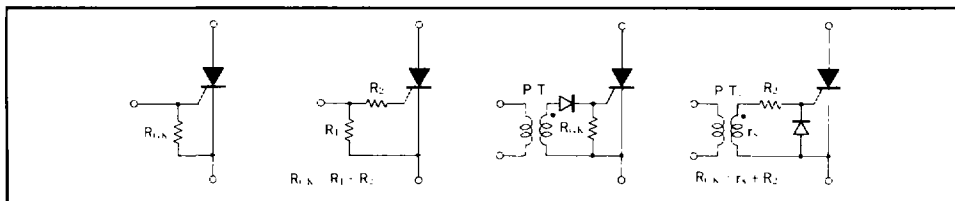

ELECTRICAL CHARACTERISTICS (T_j = 25°C)

Item	Symbol	Min.	Typ.	Max.	Units	Test Conditions
Repetitive Peak Reverse Current Repetitive Peak Off-state Current	I _{RRM} OR I _{DRM}	—	0.1	10	μA	V _{RRM} = V _{DRM} = Rated Value T _C = 25°C, R _{GK} = 1000 Ohms
		—	10	100	μA	V _{RRM} = V _{DRM} = Rated Value T _C = 110°C, R _{GK} = 1000 Ohms
Gate-Trigger Current	I _{GT}	—	30	200	μA _{dc}	T _C = 25°C, V _D = 6 Vdc, R _L = 100 Ohms R _{GK} = 1000 Ohms
		—	75	500	μA _{dc}	T _C = -40°C, V _D = 6 Vdc, R _L = 100 Ohms R _{GK} = 1000 Ohms
Gate-Trigger Voltage	V _{GT}	0.4	0.5	0.8	Volts DC	T _C = 25°C, V _D = 6 Vdc, R _L = 100 Ohms R _{GK} = 1000 Ohms
		0.5	0.7	1.0	Volts DC	T _C = -40°C, V _D = 6 Vdc, R _L = 100 Ohms R _{GK} = 1000 Ohms
		0.2	—	—	Volts DC	T _C = 110°C, V _D = Rated V _{DRM} Value R _L = 3000 Ohms, R _{GK} = 1000 Ohms
On-state Voltage	V _{TM}	—	1.8	2.2	Volts	T _C = 25°C, I _{TM} = 4 Amperes Peak, Single Half Sine Wave Pulse, 2 Millisec. Wide
Holding Current	I _H	0.3	1.0	3.0	mA _{dc}	T _C = 25°C, V _D = 12 Vdc, R _{GK} = 1000 Ohms
		0.4	1.5	5.0	mA _{dc}	T _C = -40°C, V _D = 12 Vdc, R _{GK} = 1000 Ohms
		0.14	0.6	2.0	mA _{dc}	T _C = 110°C, V _D = 12 Vdc, R _{GK} = 1000 Ohms
Latching Current	I _L	0.3	1.5	4.0	mA _{dc}	T _C = 25°C, V _D = 12 Vdc, R _{GK} = 1000 Ohms
		0.4	2.5	7.0	mA _{dc}	T _C = -40°C, V _D = 12 Vdc, R _{GK} = 1000 Ohms
Critical Rate-of-Rise of Off-state Voltage	dv/dt	—	8	—	Volts/ Micro-second	T _C = 110°C, V _D = Rated V _{DRM} Value R _{GK} = 1000 Ohms
Turn On Time	t _{ON}	—	1.2	—	Micro-seconds	T _C = 25°C, Rated V _{DRM} Value I _T = 1 Ampere, Gate Pulse = 4 Volts, 300 Ohms, 5 Microseconds Wide
Commutated Trun-Off Time	t _q	—	40	100	Micro-seconds	T _C = 110°C, rectangular current waveform Rate of rise of current < 10 amps/μsec. Rate of reversal of current < 5 amps/μsec. I _T = 1 Amp (50 μsec pulse). Repetition Rate = 60 pps. V _{RRM} = Rated V _R = 15 Volts Minimum. V _D = Rated Rate of Rise Reapplied Forward Blocking Voltage = 5 Volts/μsec. Gate Bias = 0 Volts, 100 Ohms (during turn-off time interval).

Case temperature (T_C) is measured in the center of the tab, 1.5mm from the body on Type 1 and Type 3 devices, and in the center of the anode lead, 1.5mm from the body on Type 2 devices.

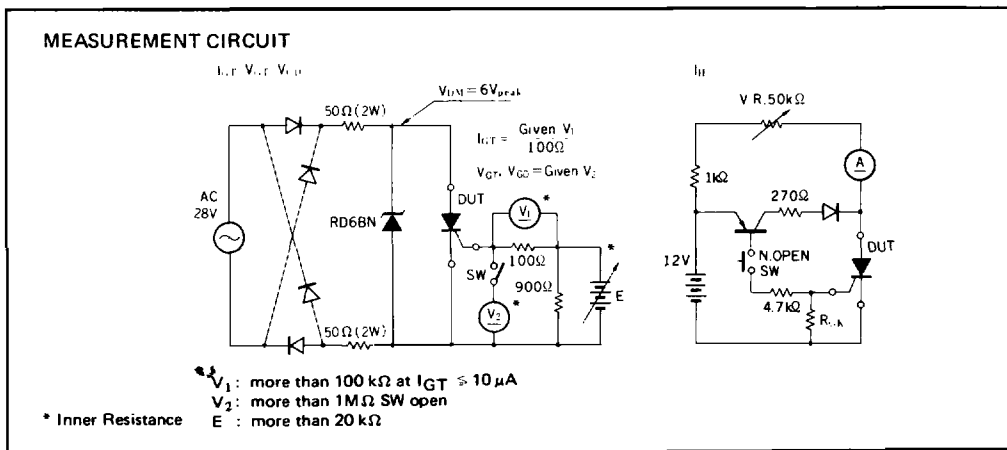

Fig. 1 $I_{TM} - V_{TM}$ Characteristics

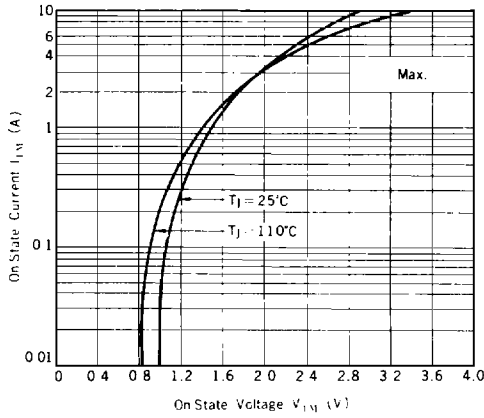

Fig. 2 $P_T(AV) - I_T(AV)$ Characteristics

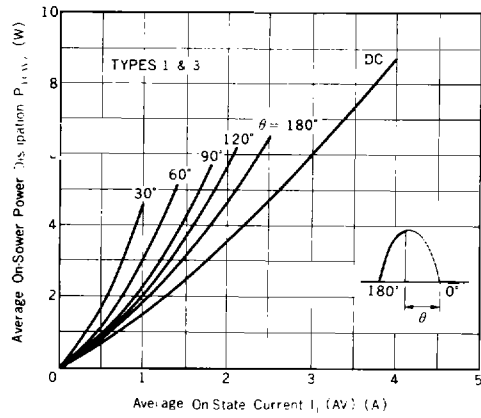

Fig. 3 $T_C - I_T(AV)$ Ratings

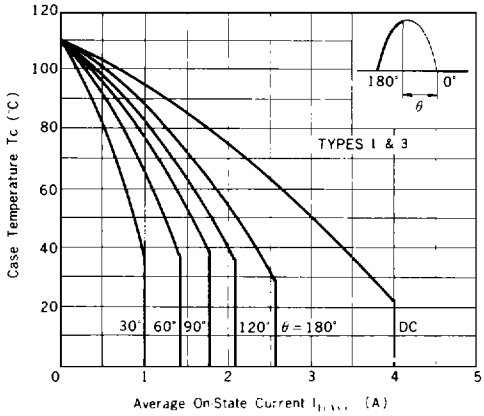

Fig. 4 $T_a - I_T(AV)$ Ratings

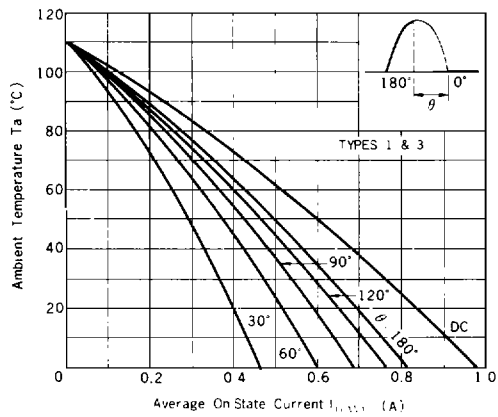

Fig. 5 $I_{GT} - T_a$ Typical Distribution

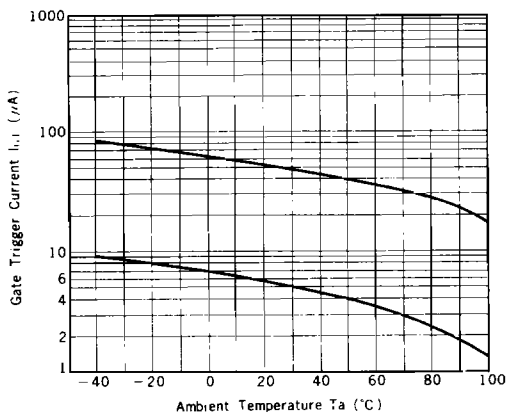

Fig. 6 $V_{GT} - T_a$ Typical Distribution

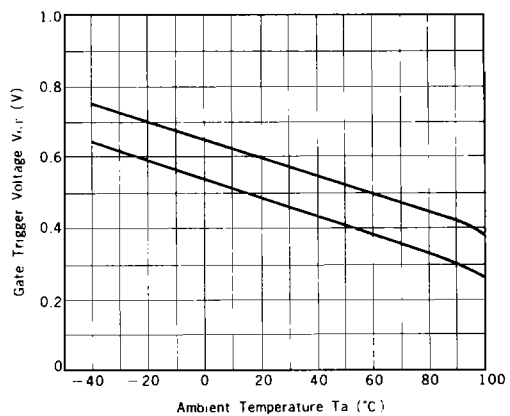

Fig. 7 I_{GT} - T_G Typical Distribution

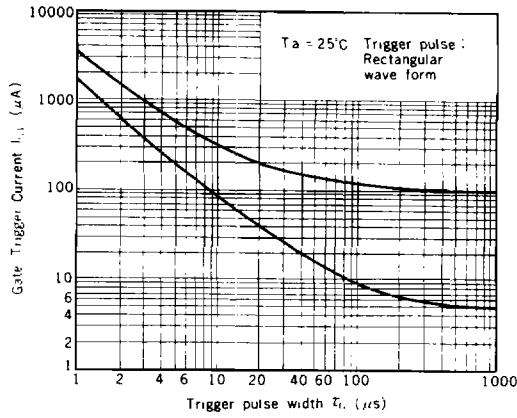

Fig. 8 V_{GT} - T_G Typical Distribution

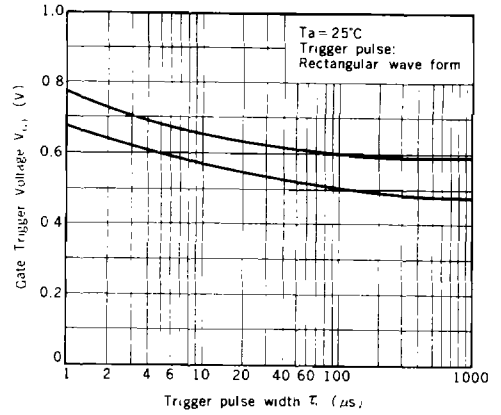

Fig. 9 I_H - T_a Typical Distribution

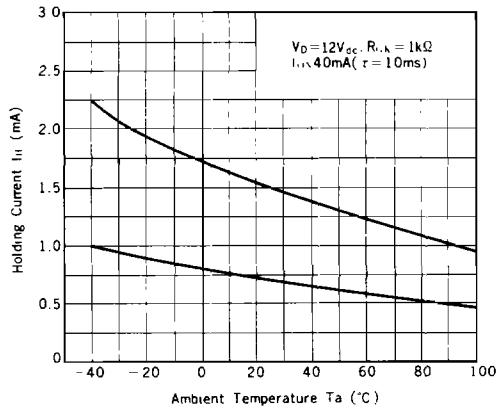

Fig. 10 I_{TSM} Ratings

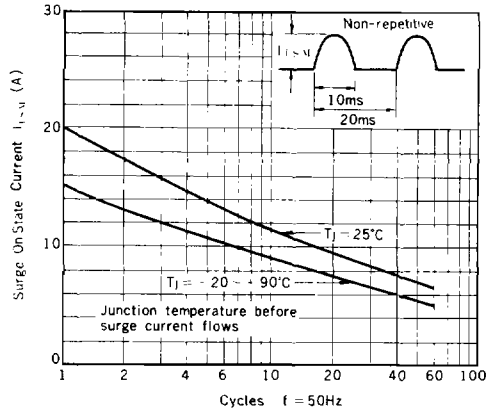
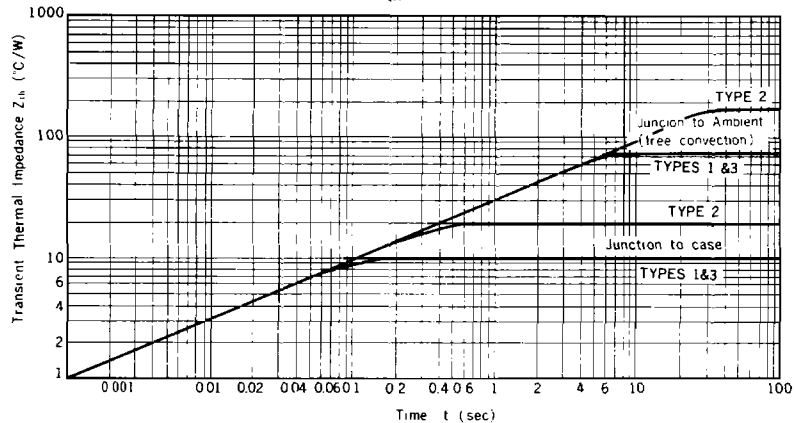
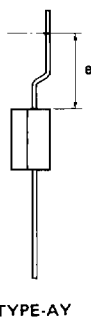
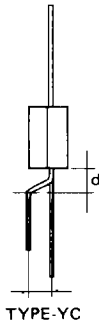
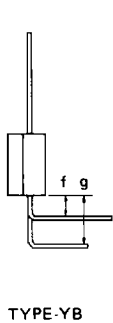
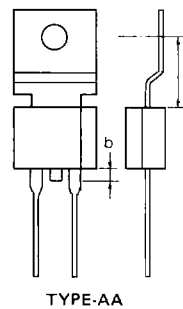
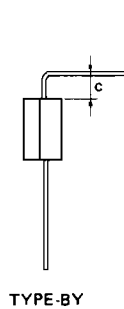
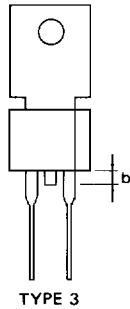
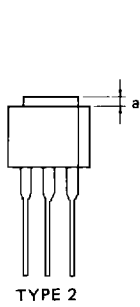

Fig. 11 Z_{th} Characteristics



SPECIAL LEAD & HEAT TAB FORMINGS



Outline Drawing (Unit: mm)			
a	1.0 ± 0.2	e	9 ± 0.2
b	1.5 ± 0.3	f	2.5 ± 0.2
c	3 ± 0.3	g	5.5 ± 0.2
d	3.0 ± 0.3	h	2.5 ± 0.5

NOTICE FOR INSTALLATION

1. Electrode leads (especially heat sink tablet) are not granted to be bent because of wet-proof. However in case it is required inevitably, a mechanical stress should not be put on mold. Fix tightly between the mold case and the area to be formed or bent.
2. Electrode leads should not to be bent more than twice over 90°. Avoid the bending within 1.5 mm from the neck of mold case.
3. The surface of heat sink for thermal radiator is to be smooth without any foreign matter.
4. Suitable torque value is 4 ~ 5 kg.cm.
5. Soldering
 - Recommended solder: PbSu (4 : 6)
Melting point 180°C
 - Dimension from the neck of leads to dipping points 4 ~ 6 mm
 - Soldering temperature and period
 - 250°C less than 5 μsec.
 - 230°C less than 10 μsec.

