

DBR-1F SERIES, 1WATT, 3KVDC, REGULATED

FEATURES:

- ✓ 3 years warranty
- ✓ 3000Vdc isolation voltage
- ✓ Fully regulated with low ripple and noise
- ✓ Dual and isolated twin output models
- ✓ Operating temperature range -40°C to +85°C
- ✓ Continuous short circuit protection



Model	Input voltage (Vdc)	Output voltage (Vdc)	Output current (mA)		Efficiency Typ.
			Min.	Max.	
DBR1-0521F	5(4.75~5.25)	±5	10	100	72%
DBR1-0522F		±9	5.5	55	72%
DBR1-0523F		±12	4	40	72%
DBR1-0524F		±15	3.3	33	72%
DBR1-0525F		±24	2.1	21	72%
DBR1-1221F	12(11.4~12.6)	±5	10	100	72%
DBR1-1222F		±9	5.5	55	72%
DBR1-1223F		±12	4	40	72%
DBR1-1224F		±15	3.3	33	72%
DBR1-1225F		±24	2.1	21	72%
DBR1-2421F	24(22.8~25.2)	±5	10	100	72%
DBR1-2422F		±9	5.5	55	72%
DBR1-2423F		±12	4	40	72%
DBR1-2424F		±15	3.3	33	72%
DBR1-2425F		±24	2.1	21	72%

Notes: other input and output models may available on request.

ELECTRICAL

Line regulation	---	±0.25%
Load regulation	10% ~ 100% full load	±1%
Ripple and noise	---	100mVp-p max.
Isolation voltage	---	3000Vdc
Short circuit protection	---	Continuous short circuit protection
Operating temperature range	---	-40°C to +85°C
MTBF	---	3.5x10 ⁶ Hrs

Notes: All the data in this article are under test with "TA+25°C, humidity<75%, rated input and rated load" mode.

DBR-1F SERIES, 1WATT, 3KVDC, REGULATED

MECHANICAL

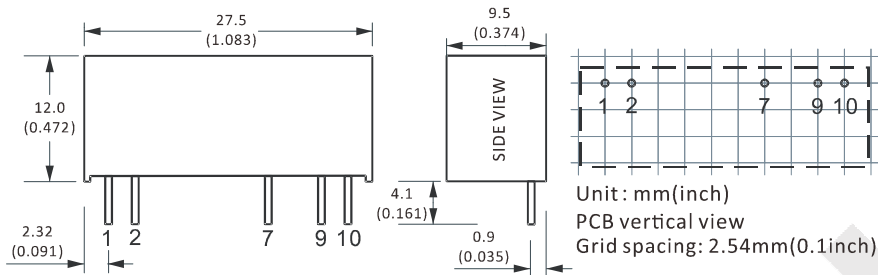

CONNECTION

PIN #	DUAL
1	+Vin
2	GND
7	+Vo
9	-Vo
10	COM

Note:

* Unit is mm(inch).

TEMPERATURE PROFILE

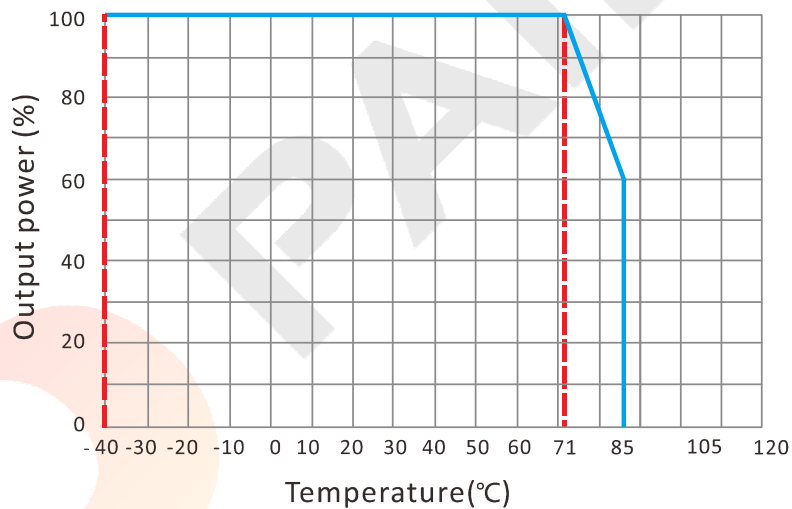

CAPACITIVE LOADS SELECTION

Vin (Vdc)	Cin (μF)	Single Output Voltage (Vdc)	Cout (μF)	Dual Output Voltage (Vdc)	Cout (μF)
5	4.7	5	10	±5	4.7
12	2.2	9	4.7	±9	2.2
24	1	12	2.2	±12	1
-	-	15/24	1	±15	0.47

DBR-1F SERIES, 1WATT, 3KVDC, REGULATED
NOTES
RECOMMENDED TEST AND APPLICATION CIRCUIT

In order to ensure the efficiency and dependability of the module, the minimum specified load must be less than 10% of rated load. If the output power is low, we recommend to add an external 10% loading resistor in parallel.

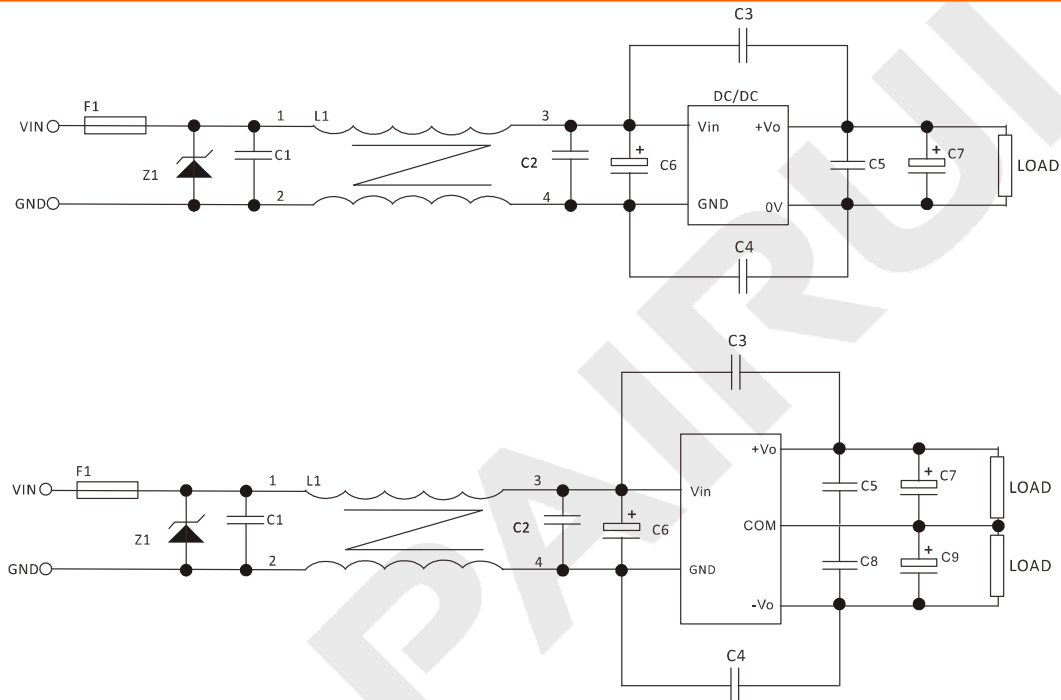

FUSE: depends on the actual input current;

TVS: depends on the actual input voltage;

Recommended capacitor: C1, C2, C5, C8, about 0.1uF; for C6, C7, C9, please check the capacitive load; C3, C4: 2KV/1nF.