

▲ CIRCUIT: SPST

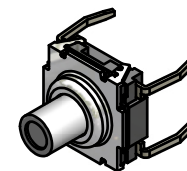

NOTES

1. ALL DIMENSIONS IN MM [INCH]
2. GENERAL TOLERANCE: X.X=± 0.4
X.XX=± 0.25
3. TERMINAL NUMBERS FOR REF. ONLY.
- ▲ 4. OPERATING FORCE: 300± 50gf
5. OPERATING LIFE: 500,000 CYCLES
6. TRAVEL: 0.5± 0.15mm
7. CONTACT RATING: 12VDC @ 50mA
8. CONTACT RESISTANCE: 100m Ω MAX
9. INSULATION RESISTANCE: 100M Ω MIN @ 100VDC.
- ▲ 10. CONTACT MATERIAL: SILVER
11. OPERATING TEMPERATURE: -40°C TO 85°C
12. PACKAGING: TUBE 60 PCS. PER
13. ▲ DENOTES CRITICAL PARAMETER
14. 2002/95/EC (ROHS) COMPLIANT

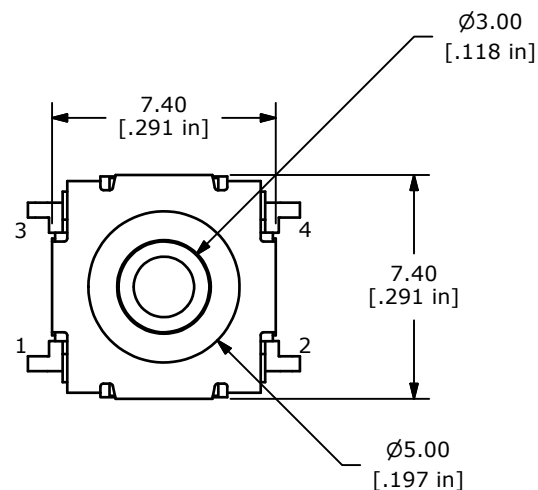
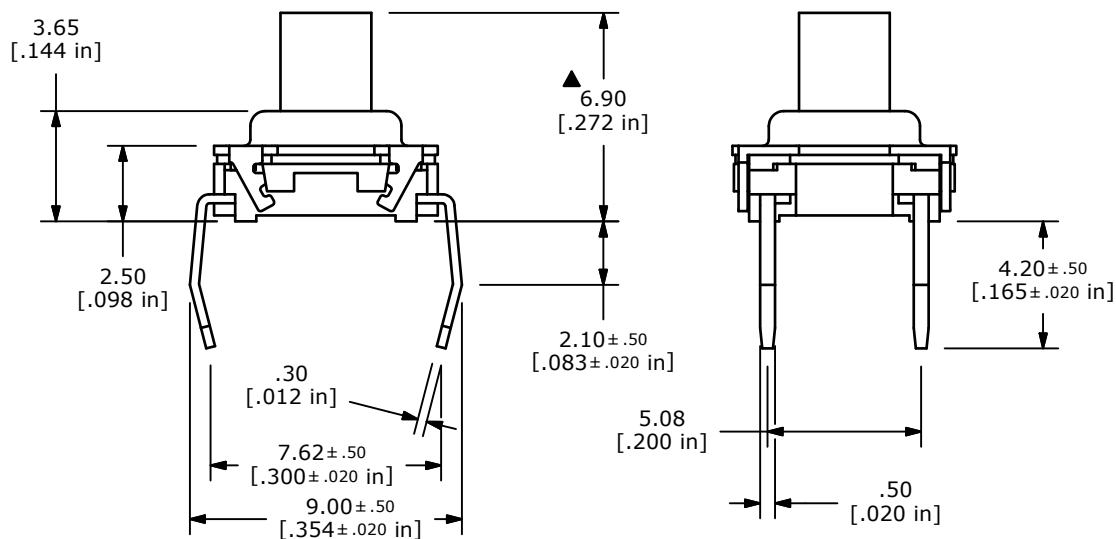

TITLE TL6100CF300QP

| | | | | |
|-----|--------|-------------|---------|----|
| A | 21179 | New Release | 7/23/13 | rc |
| REV | PCR NO | DESCRIPTION | DATE | BY |

| | | | | |
|-------|-----------|----|---------|-----|
| SCALE | DATE | DR | DWG | REV |
| | 5/21/2013 | rc | T350005 | A |

THE INFORMATION CONTAINED IN THIS DOCUMENT IS PROPRIETARY TO E-SWITCH AND IS NOT TO BE COPIED OR TRANSFERRED