

OV5620 5.17 MPixel product brief



available in
a lead-free
package

advanced digital imaging and HD video

The OV5620 is a high-performance 5.17 megapixel CMOS CameraChip™ for digital still image, video camcorder and mobile handset products. With an optical format of only 1/2.5 inches, the OV5620 takes advantage of the compact 2.2 μm pixel size of the OmniPixel2™ technology, which is one of the industry's smallest pixel sizes commercially available.

OmniPixel2's proprietary new process, which is manufactured on 0.13-micron process technology, and innovative pixel design are key to the OV5620's high dynamic range. It enables an increased fill factor of 40 percent and more vibrant and truer-to-life color reproduction. The OV5620 sensor is also designed with zero-gap micro-lens structures, which allows pixels to capture over 20 percent more light making more effective use of the smaller pixel's active area. Additionally, the OV5620 offers improved quantum efficiency, which optimizes image performance and gives rise to a further increased full well capacity.

The OV5620 incorporates a 2592 x 1944 image array and a 10-bit A/D converter capable of operating at 7.5 frames per second (fps) in full resolution. The OV5620 can also operate at 60 fps at 864 x 648 resolution enabling enhanced video viewing on TV. The large image array also allows for a digital image stabilization function.

applications

- digital still cameras
- digital video cameras
- camera phones
- PC camera/dual mode
- video conference equipment



product features

- optical black level calibration
- video or snapshot operations
- programmable/auto exposure and gain control
- programmable/auto white balance control
- horizontal and vertical sub-sampling for high frame rate with excellent image quality
- high frame rate output mode
- programmable image windowing
- variable frame rate control
- on-chip luminance average counter
- horizontal VarioPixel* (binning) 1:2, 1:3, 1:4, 1:6
- vertical VarioPixel* (binning) 1:2, 1:3
- vertical skip 1:2, 1:3, 1:4, 1:8
- flash control output (strobe pin)
- 50/60 Hz light auto detection
- image vertical flip/horizontal mirror
- defect pixel correction
- internal/external frame synchronization
- serial bus interface

OV5620

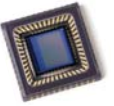

ordering information

- OV05620-C03A (color, CLCC-48)
- OV05620-G02A (color, COB, std backgrounding)
- OV05620-G00A (color, COB, no backgrounding)

product specifications

- array size: 2592 x 1944
- power supply
analog: 2.6 - 3.0V
digital: 1.2V ± 5%
- output format: 10-bit digital RGB Raw data
- lens size: 1/2.5"
- maximum system clock: 48 MHz
- max image transfer rate
full: 2592 x 1944
SXGA: 1280 x 960
D1: 720 x 480
VGA: 640 x 480
- pixel size: 2.2 μm x 2.2 μm

block diagram

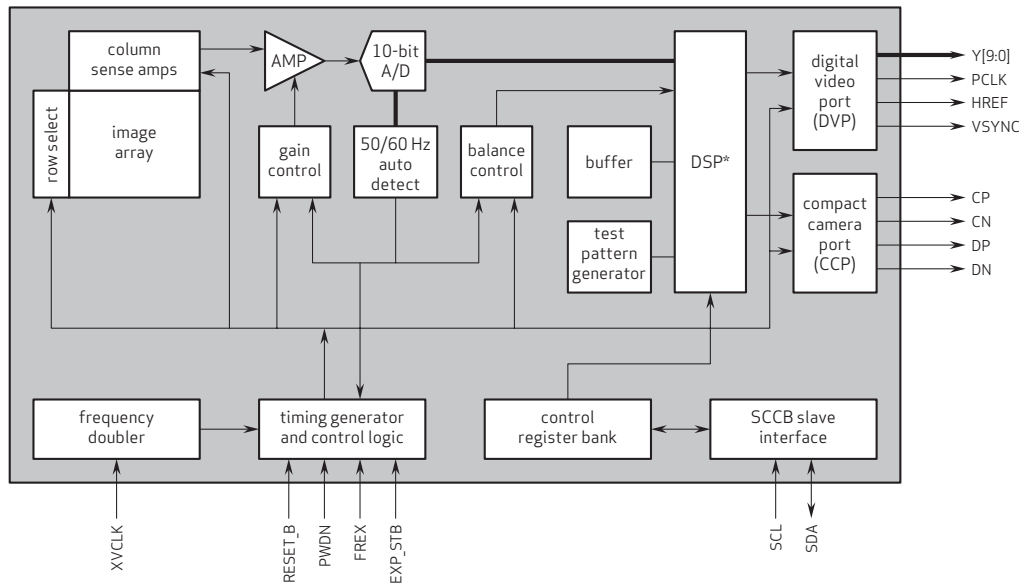

note 1 DSP* (white/black pixel correction, etc.)

5620_PB_001

1341 Orleans Drive
Sunnyvale, CA 94089
USA

tel: + 1 408 542 3000
fax: + 1 408 542 3001
www.ovt.com

OmniVision reserves the right to make changes to their products or to discontinue any product or service without further notice. 'OmniVision', the OmniVision logo, 'VarioPixel', and 'OmniPixel' are registered trademarks of OmniVision Technology. All other trademarks are the property of their respective owners.