

SONY CX10045

CCD CAMERA SIGNAL PROCESSING WITH SAMPLE-HOLD CIRCUIT

Description: CX10045 is a bipolar IC designed for CCD camera signal processing. It samples the CCD image signal and holds the sample signal with a specified timing pulse to provide the final analog video signal output.

Features:

- Double sample processing to reduce random noises in the CCD signal with appropriate sampling pulse.
- Integrated analog signal processing of B/W CCD camera is possible when combined with CX10046 and CX10047.

Package outline

Unit: mm

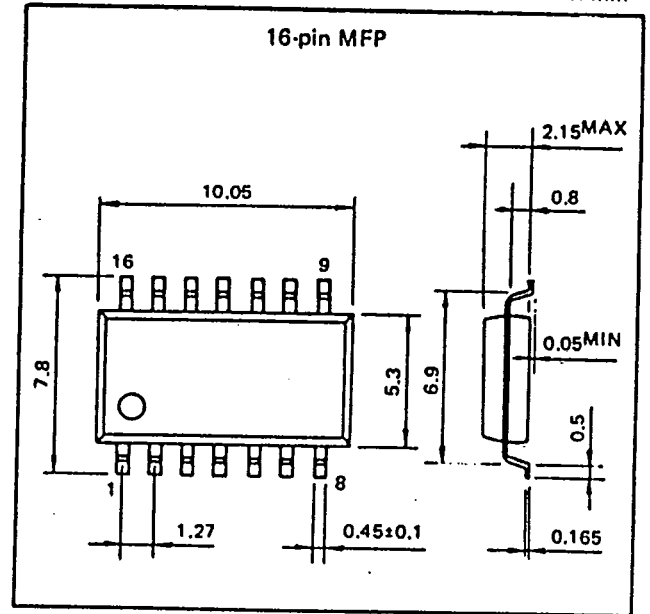

ABSOLUTE MAXIMUM RATING (Ta = 25°C)

• Power supply voltage	V _{CC}	15	V
• Terminal voltage	V _{IN}	-0.3 ~ V _{CC} + 0.3	V
• Operating Temperature	T _{opr}	-10 ~ +60	°C
• Storage temperature	T _{stg}	-50 ~ +125	°C
• Allowable power dissipation	P _D	390*	mW T _a ≤ 60°C

* When mounted on a double glass epoxy substrate (30mm square, 0.8mm thick)

RECOMMENDED OPERATING CONDITION

• Power supply voltage	V _{CC}	8.0 ~ 9.5	V
• Logic input voltage	V _{I1} V _{I2}	0 ~ 55	V

BLOCK DIAGRAM

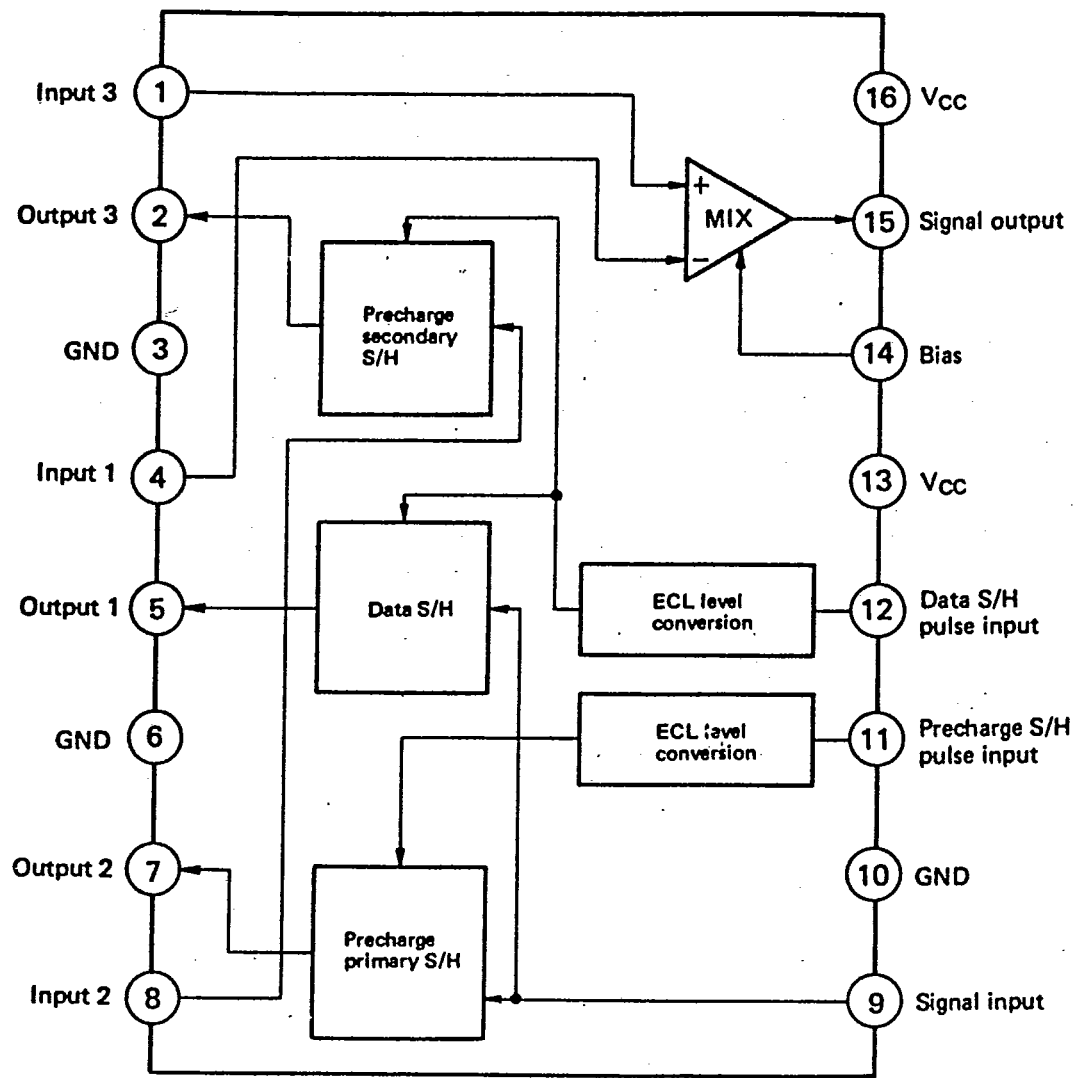

CX10045

SONY.

ELECTRICAL CHARACTERISTICS

(Ta=25°C, VCC=8.5V)

Measuring item	Symbol	V _{IN} (mVpp)	Measuring point	Conditions	Measuring circuit	Min	Typ	Max	Unit
Power supply current	I _{CC}	-	16 13	V ₁₁ =V ₁₂ =5.0V	1	16.8	24.0	34.3	mA
Output voltage	V _{2H} , V _{5H} , V _{7H}	-	2.5.7	V ₁₁ =V ₁₂ =4.4V	1	6.1	6.5	6.9	V
Output voltage difference	ΔV ₂ , ΔV ₅ , ΔV ₇	-	2.5.7	Potential difference between V ₁₂ =4.4V and 0.4V when I _n =-100μA (n=2.5.7) and V ₁₁ =4.4V.	2	1.85	2.1	-	V
Discharge current	I _{2D} , I _{5D} I _{7D}	-	2.5.7	V ₁₁ =V ₁₂ =4.4V, V _n =7.1V(n=2.5.7)	1	1.3	2.0	-	mA
Voltage gain	G ₈₋₂ , G ₉₋₅ , G ₉₋₇	V _{IN} 9 800	2.5.7	f=100KHz	3	-0.4	0	0.3	dB
Frequency bandwidth	BW ₈₋₂ , BW ₉₋₅ , BW ₉₋₇	V _{IN} 9 800	2.5.7	-3dB frequency	3	25	50	-	MHz
Output voltage	V _{15H}	-	15	V ₁₁ =V ₁₂ =4.4V, V ₁₄ =0	1	6.1	6.6	7.1	V
Output voltage	V _{15L}	-	15	V ₁₁ =V ₁₂ =4.4V, V ₁₄ =7.8V	1	2.3	2.8	3.3	V
Voltage gain	G ₁₋₁₅	V _{IN} 1 1000	15	f=100KHz	3	3.1	3.8	4.5	dB
Voltage gain	G ₄₋₁₅	V _{IN} 4 1000	15	f=100KHz	3	3.3	3.8	4.3	dB
Frequency bandwidth	BW ₁₋₁₅	V _{IN} 1 1000	15	-3dB frequency	3	15	30	-	MHz
Frequency bandwidth	BW ₄₋₁₅	V _{IN} 4 1000	15	-3dB frequency	3	15	30	-	MHz

ELECTRICAL CHARACTERISTIC MEASURING CIRCUIT

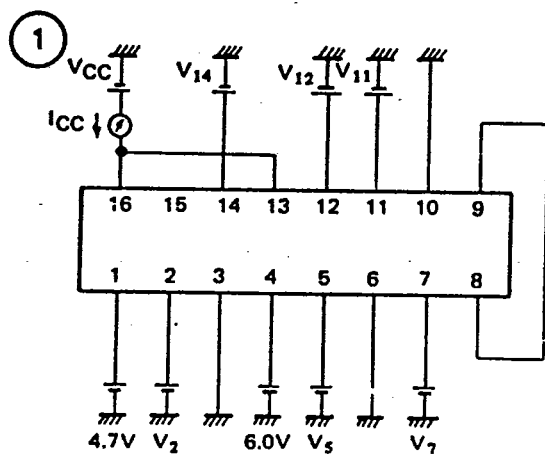

• Unless specified, V₂, V₅ and V₇ are open with V₁₄=4.9V

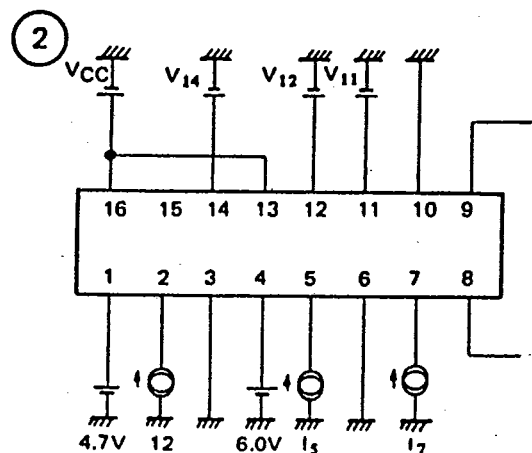

• Unless specified, I₂ = I₅ = I₇ = 0 with V₁₄ = 4.9V

CX10045

SONY.

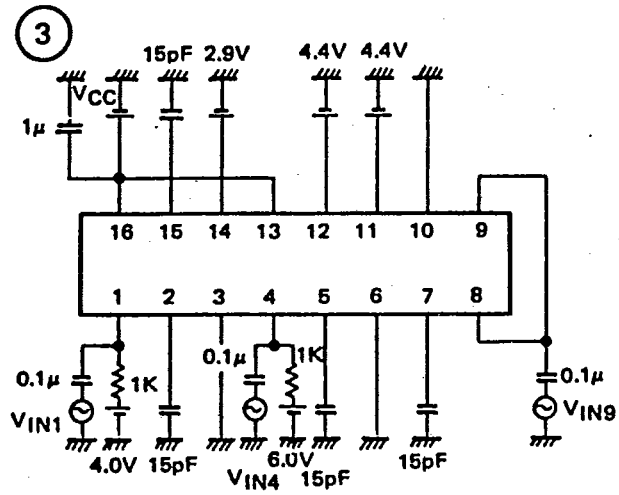

• 15pF includes the stray capacitance of the measuring equipment.