

液晶之友 电话: 020-33819057
Http://www.lcdfriends.com

HANTRONIX

PRODUCT SPECIFICATION

HDM6448-6

640 x 480 GRAPHICS
LCD DISPLAY MODULE

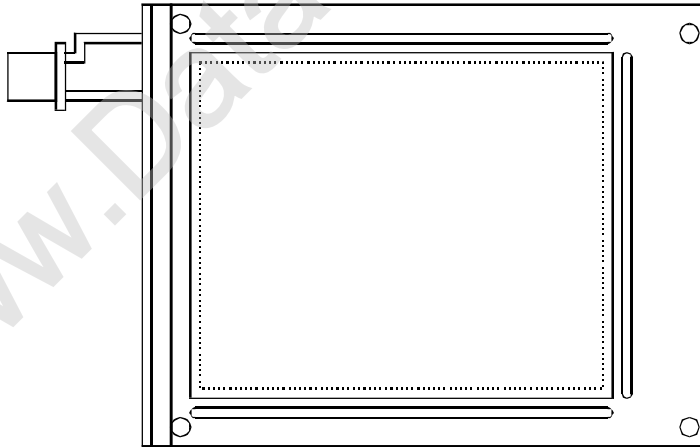

HANTRONIX, INC. 10080 BUBB RD. CUPERTINO, CA 95014	Q.A.:	REV.:	HDM6448-6	SHEET 1 OF 15
	JB	1.0		DATE: 6/15/99

MECHANICAL DATA

(1) Product No.	
(2) Module Size	167.7 (W)mm x 122.8 (H)mm x 5.3 typ.(D)mm
(3) Lcd Viewing Area	125.6 (W)mm x 95.2 (H)mm
(4) Dot Size	0.17 (W)mm x 0.17 (H)mm
(5) Dot Pitch	0.19 (W)mm x 0.19 (H)mm
(6) Number of Dots	640 (W) x 480 (H)Dots
(8) Duty	1/240
(9) LCD Display Mode	FSTN: Black and White(Normally White/Positive Image) Rear Polarizer: Transflective(High Transparency)
(10) Viewing Direction	6 O'clock
(11) Backlight	CCFT
(12) Controller	Excluded
(13) DC/DC Converter	Excluded
(14) Weight	150 g(approx.)

HANTRONIX, INC. 10080 BUBB RD. CUPERTINO, CA 95014	Q.A.:	REV.:	HDM6448-6	SHEET 2 OF 15
	JB	1.0		DATE: 6/15/99

ABSOLUTE MAXIMUM RATINGS

(1) ELECTRICAL ABSOLUTE RATINGS

VSS=0 V Standard

ITEM	SYMBOL	MIN	MAX	UNIT	COMMENT
Supply Voltage (Logic)	VDD-VSS	0	6.0	V	T _a = 25°C
Supply Voltage (LCD Drive)	VEE-VSS	0	30.0	V	T _a = 25°C
Input Voltage	VIN	0	VDD	V	T _a = 25°C
Static Electricity	-	-	-	-	Note 1

(2) ENVIRONMENTAL ABSOLUTE MAXIMUM RATINGS

ITEM	OPERATION		STORAGE	
	MIN.	MAX.	MIN.	MAX.
Ambient Temperature	-20	70	-30	80
Humidity (Without Condensation)	Note 2,4		Note 3,4	
Vibration(Note 5)	-		49m/s ² (5G)	

Note 1 LCM should be grounded during handling LCM.

Note 2 T_a ≤ 70°C : 75%RH max
 T_a > 70°C : Absolute humidity must be lower than the humidity of 75%RH at 70°C

Note 3 T_a at -30°C will be < 48 hrs, at 80°C will be < 120 hrs

Note 4 Background color will change slightly depending on ambient temperature. That phenomenon is reversible.

Note 5

Frequency (Hz)	10~55~10/1 min
Vibration Width	1.5 m/m
Vibration Direction	X/Y/Z
Vibration Time	15 min/cycle X 3 directions

HANTRONIX, INC. 10080 BUBB RD. CUPERTINO, CA 95014	Q.A.:	REV.:	HDM6448-6	SHEET 3 OF 15
	JB	1.0		DATE: 6/15/99

ELECTRICAL CHARACTERISTICS

ITEM	SYMBOL	CONDITION	MIN.	TYP.	MAX.	UNIT	
Power Supply for Logic	VDD-VSS	Ta = 25°C	3.0	3.3	5.5	V	
Input Voltage	VIL	L level	0	-	0.2VDD	V	
	VIH	H level	0.8VDD	-	VDD	V	
Recommand LCD Module Driving Voltage	VEE-VSS	VDD=3.3V Bias=1/11.3	Ta=-20°C	21.9	22.3	22.7	V
			Ta=0°C	21.0	21.4	21.9	
			Ta=25°C	20.1	20.5	20.9	
			Ta=50°C	18.6	19.0	19.4	
			Ta=65°C	17.3	17.7	18.1	
Power Supply Current for LCM	IDD	VDD=3.3V VDD-VEE=20.5V FLM=70Hz Pattern : <div style="display: flex; flex-wrap: wrap; gap: 2px;"> ■ □ ■ □ □ ■ □ ■ ■ □ ■ □ </div>	-	0.7	3.0	mA	
	IEE		-	6.7	15.0		
CCFT	Open Voltage	V _{OPEN}	Lamp Current = 5 mArms Frequency = 55 KHz	-	440	-	Vrms
	Lamp Voltage	V _L		-	330	-	Vrms

OPTICAL CHARACTERISTICS

AT Vop

ITEM MODE		Cr(Contrast Ratio)						θ (Viewing Angle)		ϕ (Viewing Angle)	
		0°C		25°C		50°C		25°C		25°C	
		MIN.	TYP.	MIN.	TYP.	MIN.	TYP.	MIN.	TYP.	MIN.	TYP.
H	J	-	6.5	-	6.0	-	5.0	-	37	-	46
NOTE		NOTE 6						NOTE 5			

NOTE :

H : TRANSFLECTIVE(HIGH TRANSPARENCY)

J: NORMALLY WHITE

AT $\theta=0^\circ$ $\phi=0^\circ$

ITEM	SYMBOL	CONDITION	MIN.	TYP.	MAX.	UNIT	NOTE
Response Time (rise)	Tr	-20°C	-	1700	2600	ms	Fig.2
		0°C	-	370	560		
		25°C	-	200	300		
		50°C	-	90	150		
		65°C	-	80	120		
Response Time (fall)	Tr	-20°C	-	900	1400	ms	Fig.2
		0°C	-	350	530		
		25°C	-	150	230		
		50°C	-	80	120		
		65°C	-	70	110		

HANTRONIX, INC.
10080 BUBB RD.
CUPERTINO, CA 95014

Q.A.:

JB

REV.:

1.0

HDM6448-6

SHEET 5 OF 15

DATE:

6/15/99

(Fig.1)

Definition of Operation Voltage(Vop)

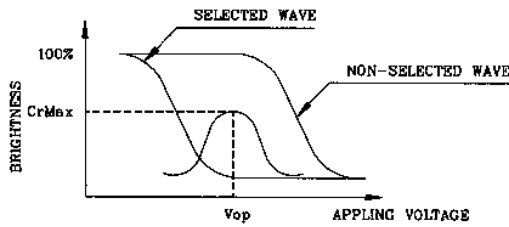

(positive type)

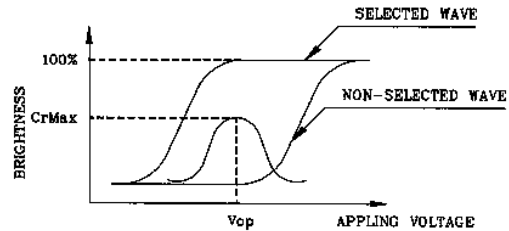

(negative type)

*Conditions

Viewing Angle : 0
 Frame Frequency : 70Hz
 Applying Waveform : 1/N duty 1/a bias

(Fig.2)

Definition of Response Time(Tr,Tf)

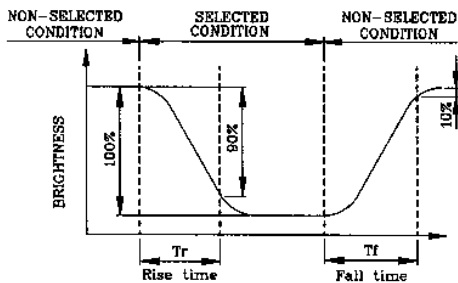

(positive type)

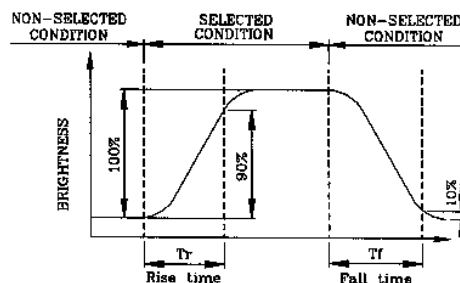

(negative type)

*Conditions

Operating Voltage : Vop
 Viewing Angle (θ,φ) : (0,0)
 Frame Frequency : 70Hz
 Applying Waveform : 1/N duty 1/a bias

(Fig.3)

Description of Measuring Equipment and Driving Waveforms

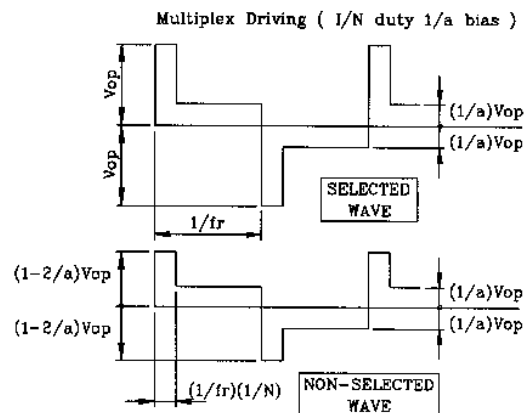
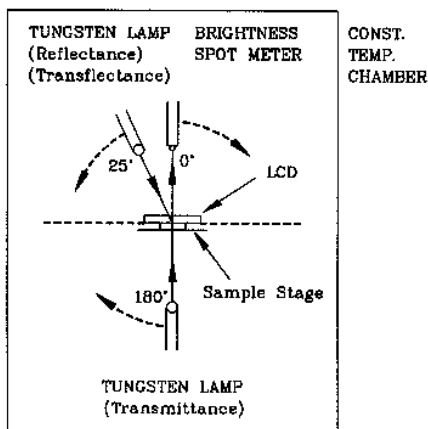

(Fig. 4)

Definition of Viewing Direction

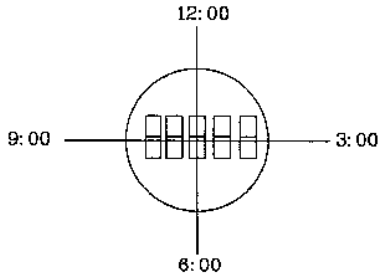

(Fig. 5)

Definition of Viewing Angle

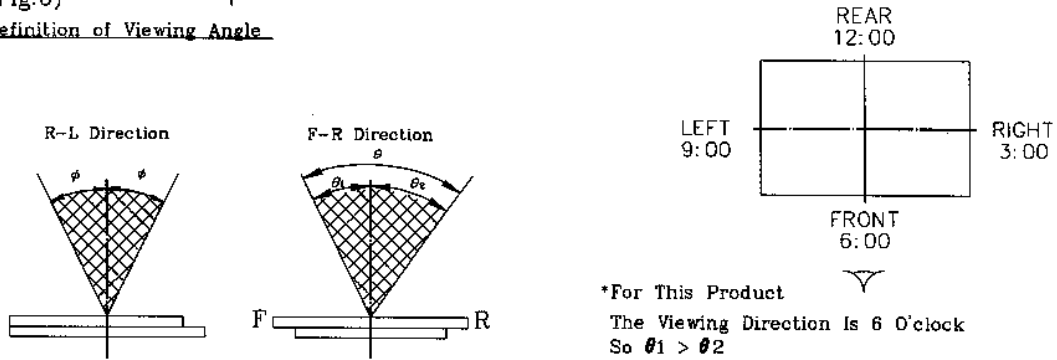

$\theta = \theta_1 + \theta_2$

*Conditions

- Operating Voltage : V_{op}
- Frame Frequency : 70Hz
- Applying Waveform : 1/N duty 1/a bias
- Contrast Ratio : larger than 2

(Fig. 6)

Definition of Contrast Ratio (Cr)

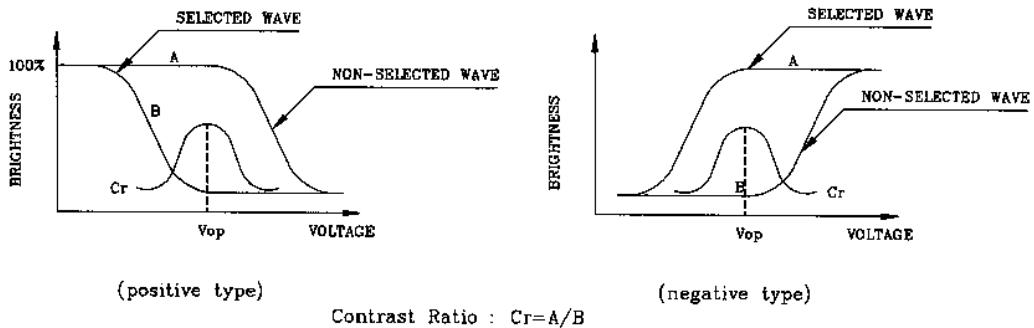

*Conditions

- Viewing Angle : 0
- Frame Frequency : 70Hz
- Applying Waveform : 1/N duty 1/a bias

HANTRONIX, INC. 10080 BUBB RD. CUPERTINO, CA 95014	Q.A.:	REV.:	HDM6448-6	SHEET 7 OF 15
	JB	1.0		DATE:

BLOCK DIAGRAM

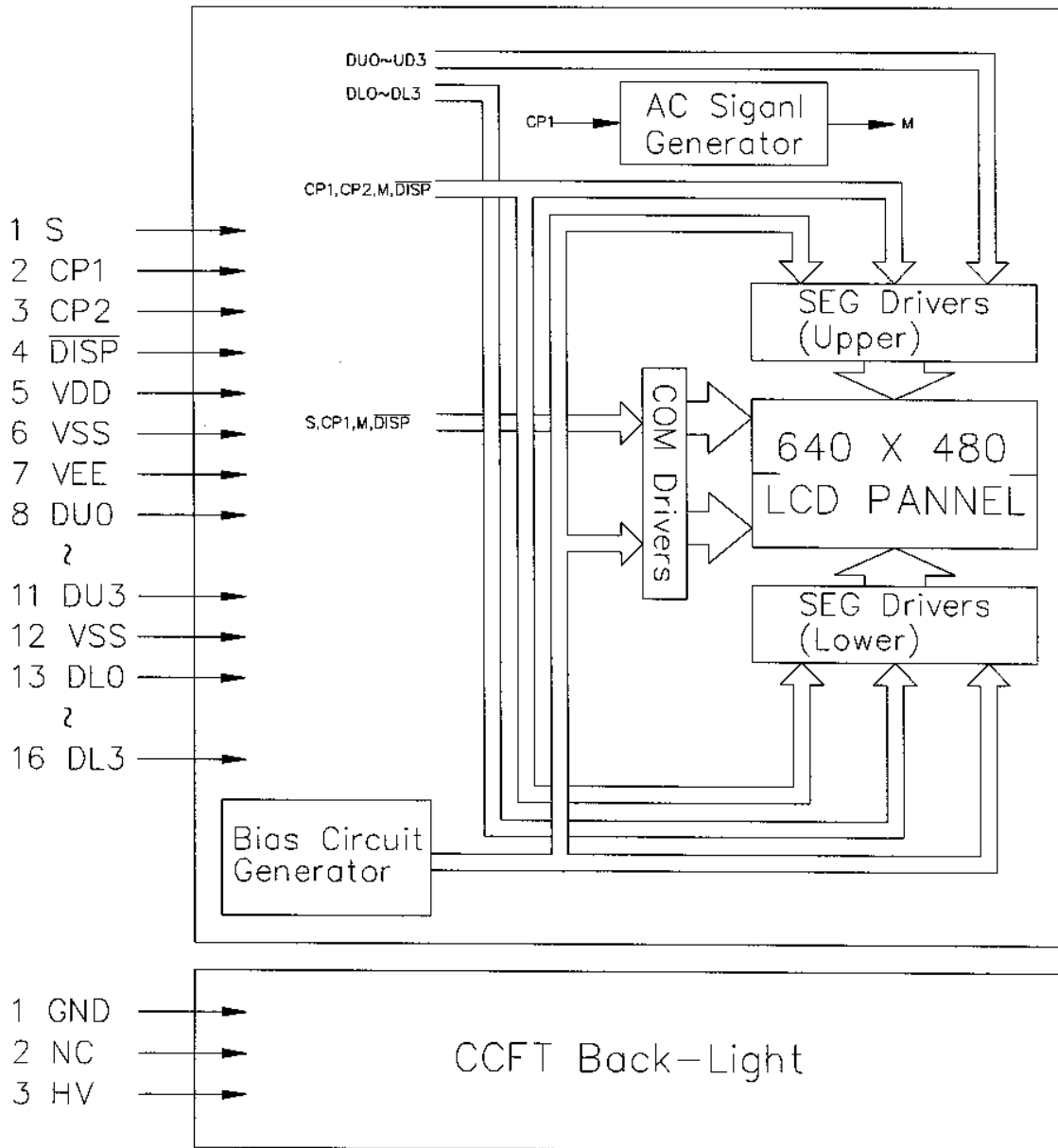

* AC Signal Setting

J1	J2	J3	J4	J5	J6	J7	J8
L	H	L	L	H	L	L	L

HANTRONIX, INC.
10080 BUBB RD.
CUPERTINO, CA 95014

Q.A.:
JB

REV.:
1.0

HDM6448-6

SHEET 8 OF 15

DATE:
6/15/99

INTERNAL PIN CONNECTION

LCD

Pin No.	Symbol	Level	Function
1	S	H/L	SCAN START-UP SIGNAL
2	CP1	H→L	INPUT DATA LATCH SIGNAL
3	CP2	H→L	DATA INPUT CLOCK SIGNAL
4	DISP	H/L	DISPLAY OFF ("H"=ON,"L"=OFF)
5	VDD	-	POWER SUPPLY FOR LOGIC (+)
6	VSS	-	SIGNAL GROUND (GND)
7	VEE	-	POWER SUPPLY FOR LCD (+)
8	DU0	H/L	DISPLAY DATA (UPPER HALF)
9	DU1		
10	DU2		
11	DU3		
12	VSS	-	SIGNAL GROUND (GND)
13	DL0	H/L	DISPLAY DATA (LOWER HALF)
14	DL1		
15	DL2		
16	DL3		

CCFT

Pin No.	Symbol	Level	Function
1	GND	-	GROUND LINE (INVERTER)
2	NC	-	NO CONNECTION
3	HV	-	HIGH VOLTAGE LINE (INVERTER)

LCD

Used connector : FH12A-16S-0.5SH (HIROSE)

Mating cable : FFC or FPC (Pitch 0.5mm,16 pins,Conact Partion
Thickness 0.3mm)

CCFT

Used connector : BHR-03VS-1 (JST)

Mating connector : SM02(80)B-BHS-1

HANTRONIX, INC. 10080 BUBB RD. CUPERTINO, CA 95014	Q.A.:	REV.:	HDM6448-6	SHEET 9 OF 15
	JB	1.0		DATE: 6/15/99

POWER SUPPLY

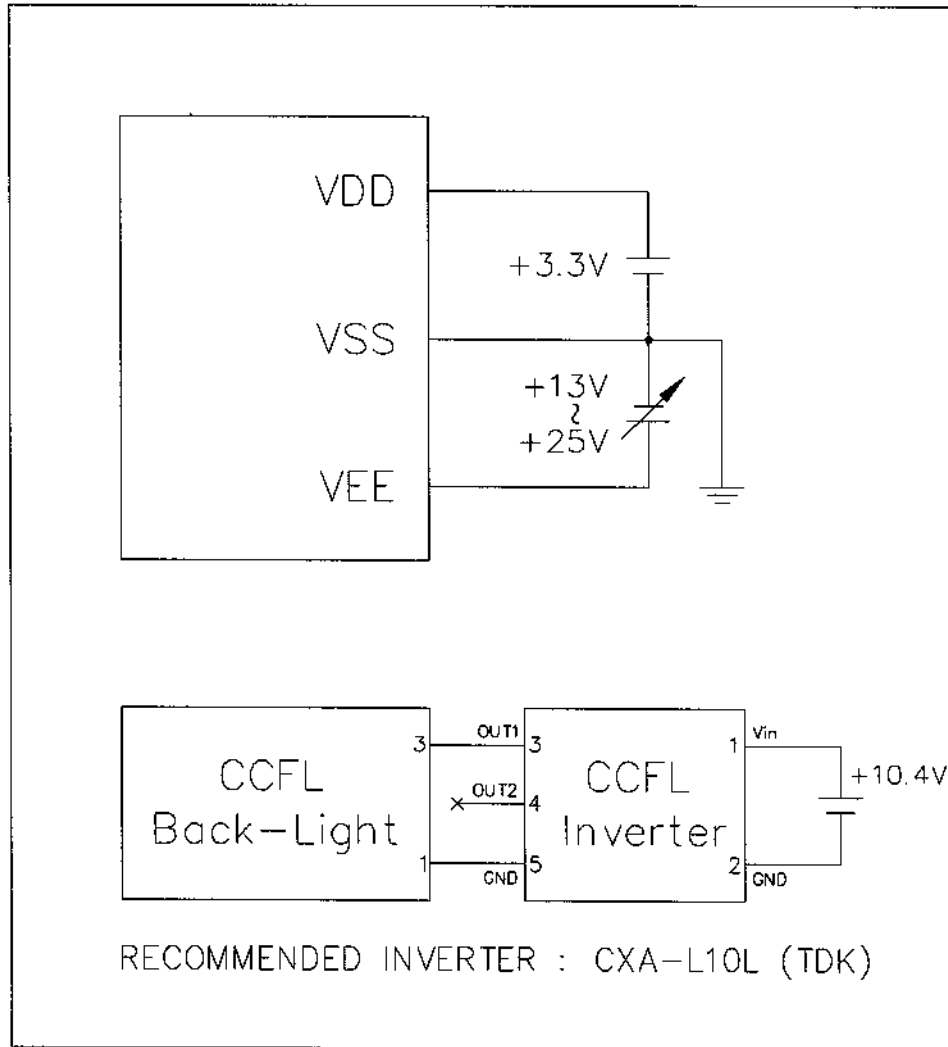

HANTRONIX, INC. 10080 BUBB RD. CUPERTINO, CA 95014	Q.A.:	REV.:	HDM6448-6	SHEET 10 OF 15
	JB	1.0		DATE: 6/15/99

TIMING CHARACTERISTICS

8-1. INTERFACE TIMING

@VDD=2.5~5.5V

ITEM	SYMBOL	MIN.	TYP.	MAX.	UNIT
Shift Clock Period	t_{cp}	125	-	-	ns
"CP2" PULSE WIDTH	t_w	51	-	-	ns
CLOCK RISE, FALL TIME	t_r, t_f	-	-	50	ns
DATA SETUP TIME	t_{dsu}	30	-	-	ns
DATA HOLD TIME	t_{dhd}	50	-	-	ns
"CP2" → "CP1" FALL TIME	t_{lsu}	51	-	-	ns
"CP1" → "CP2" FALL TIME	t_{lc}	51	-	-	ns
"S" SETUP TIME	t_{setup}	100	-	-	ns
"S" HOLD TIME	t_{hold}	100	-	-	ns
"CP1" PULSE WIDTH	t_{wc}	65	-	-	ns

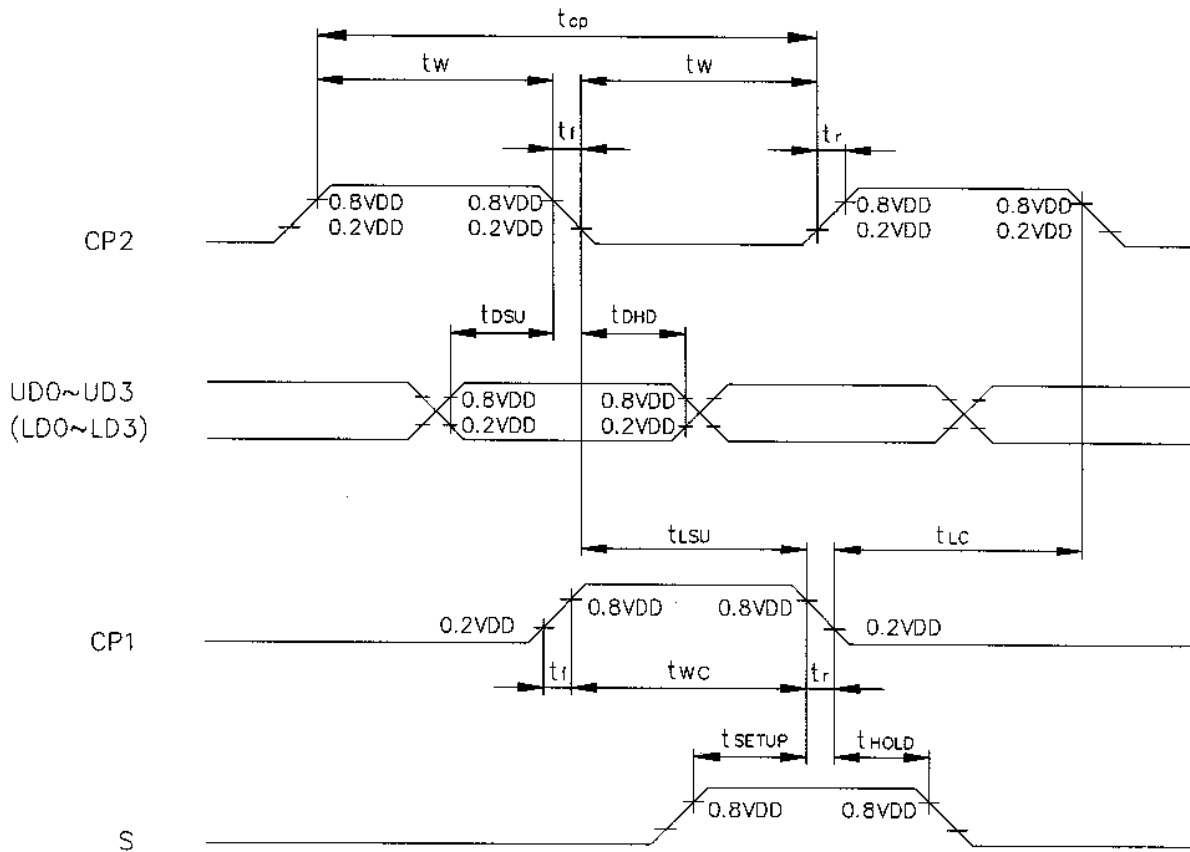

HANTRONIX, INC.
10080 BUBB RD.
CUPERTINO, CA 95014

Q.A.:

JB

REV.:

1.0

HDM6448-6

SHEET 11 OF 15

DATE:

6/15/99

POWER ON/OFF TIMING

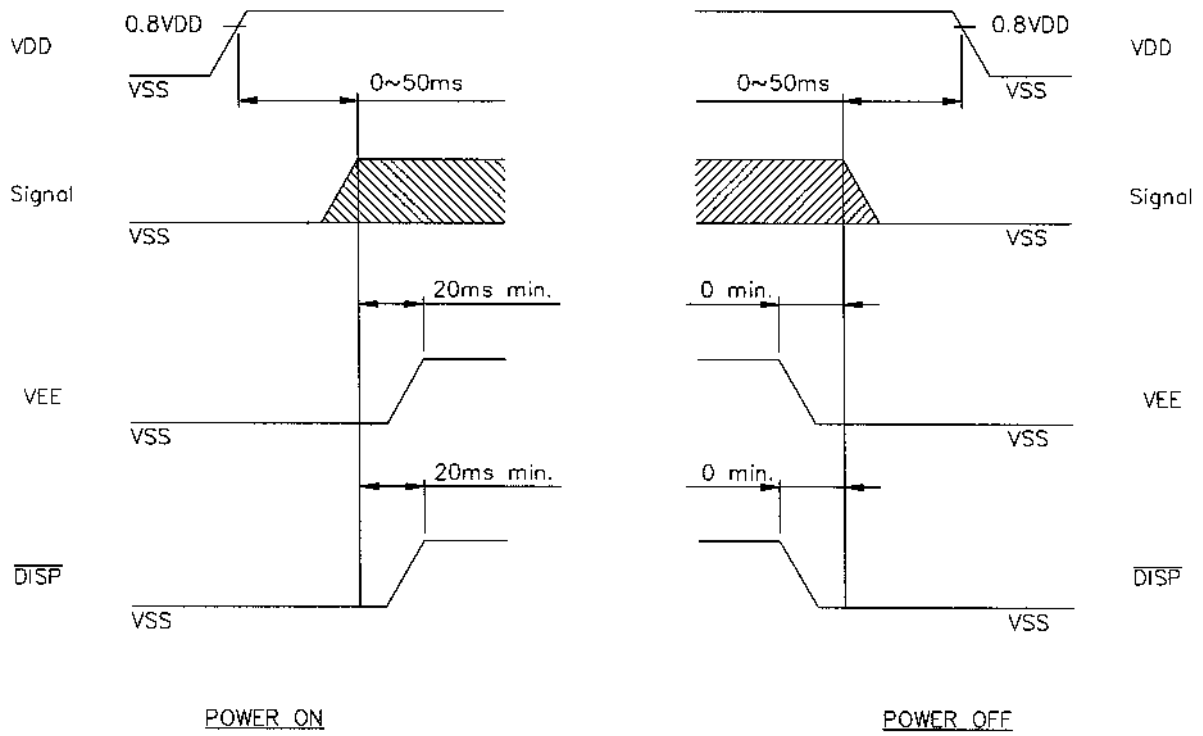

The missing pixels may occur when the LCM is driven beyond above power interface timing sequence.

HANTRONIX, INC. 10080 BUBB RD. CUPERTINO, CA 95014	Q.A.:	REV.:	HDM6448-6	SHEET 12 OF 15
	JB	1.0		DATE:

DISPLAY PATTERN

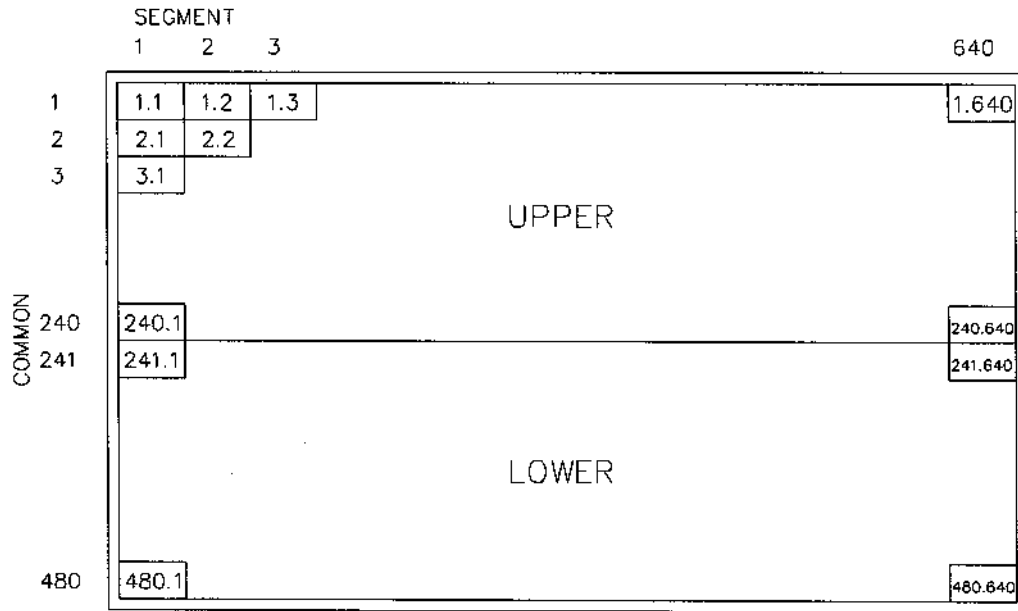

1.1 MEANS 1ST COMMON 1ST SEGMENT DOT

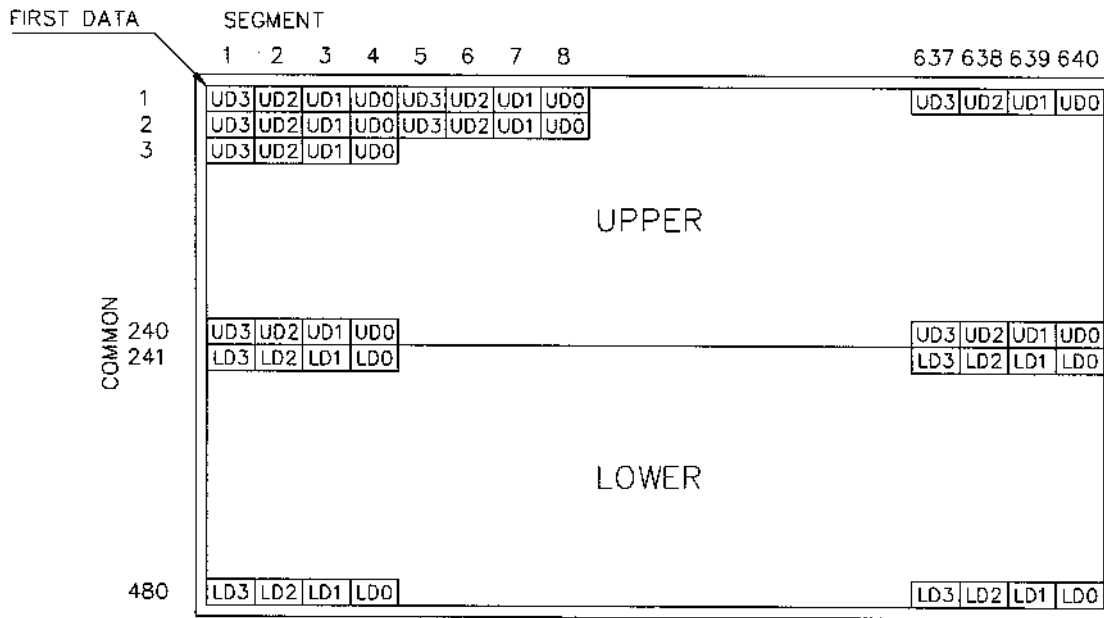

HANTRONIX, INC.
10080 BUBB RD.
CUPERTINO, CA 95014

Q.A.:

JB

REV.:

1.0

HDM6448-6

SHEET 13 OF 15

DATE:

6/15/99

RELIABILITY TEST

NO	ITEM	CONDITION			STANDARD	NOTE
1	High Temp. Storage	70°C	120HR		Appearance without defect	
2	Low Temp. Storage	-25°C	120HR		Appearance without defect	
3	High Temp. & High Humi. Storage	40°C 90%RH	120HR		Appearance without defect	
4	Thermal Shock	-20°C, 30min → 25°C, 5min → 60°C, 30min → 25°C, 5min (1 cycle)			Appearance without defect	5 cycles

HANTRONIX, INC. 10080 BUBB RD. CUPERTINO, CA 95014	Q.A.:	REV.:	HDM6448-6	SHEET 14 OF 15
	JB	1.0		DATE:

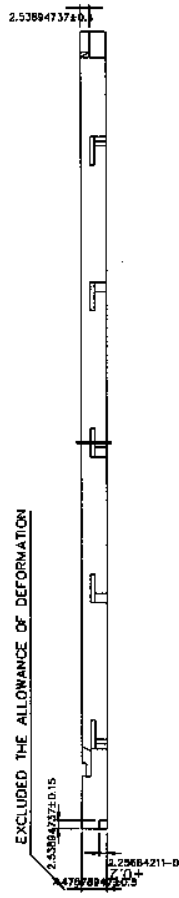
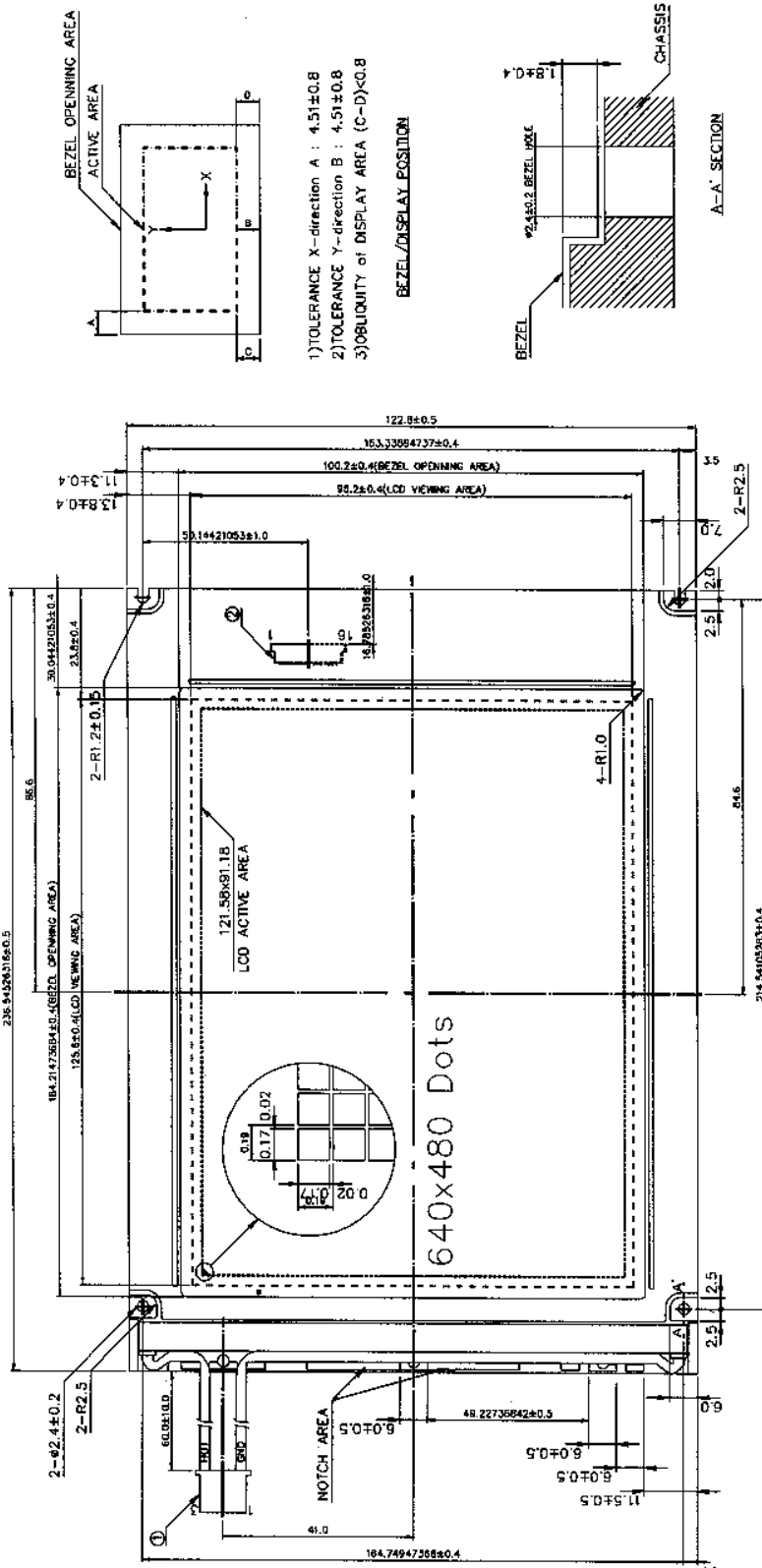

- BEZEL/DISPLAY POSITION
- 1) TOLERANCE X-direction A : 4.51±0.8
 - 2) TOLERANCE Y-direction B : 4.51±0.8
 - 3) OBSCURITY of DISPLAY AREA (C-D) < 0.8

NOTES :

1. RESOLUTION : 640 X 480 DOTS
2. TOLERANCE NO SPECIFIED: ±0.5mm
3. ① CCFT CONNECTOR : BHR-03VS-1 (JST) OR COMPATIBLE
- ② INTERFACE CONNECTOR : FH12A-16S-0.5SH (HIROSE) OR COMPATIBLE
4. 顯示區域為LCD VIEWING AREA (125.6x95.2) 內, LCD VIEWING AREA與 BEZEL OPENING AREA 之間為框膠區域, 當將組顯示時, LCD VIEWING AREA (125.6x95.2) 外之框膠區域應出廠時為可接受之顯示品質

<p>HANTRONIX, INC. 10080 BUBB RD. CUPERTINO, CA 95014</p>	<p>Q.A.: JB</p>	<p>REV.: 1.0</p>	<p>HDM6448-6</p>	<p>SHEET 15 OF 15 DATE: 6/15/99</p>
--	----------------------------	-----------------------------	-------------------------	---