

FEATURES

- High Output Power: $P_{1dB} = 31.0\text{dBm}$ (Typ.)
- High Gain: $G_{1dB} = 21.0\text{dB}$ (Typ.)
- High PAE: $\eta_{add} = 30\%$ (Typ.)
- Impedance Matched $Z_{in}/Z_{out} = 50\Omega$
- 0.25 μm PHEMT Technology

DESCRIPTION

The FMM5805X is a high-gain, high power, 3-stage MMIC amplifier designed for operation in the 17.5-20.0 GHz frequency range. This amplifier has an input and output designed for use in 50 Ω systems. This device is well suited for point-to-point communication applications.

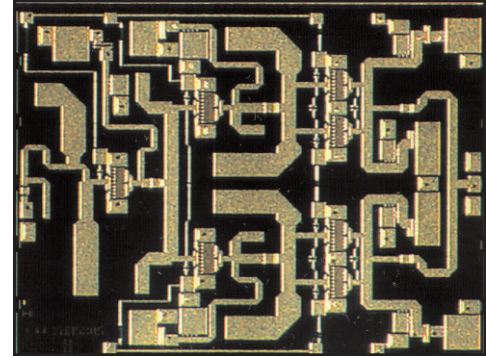

Eudyna's stringent Quality Assurance Program assures the highest reliability and consistent performance.

ABSOLUTE MAXIMUM RATING (Ambient Temperature $T_a=25^\circ\text{C}$)

Item	Symbol	Condition	Rating	Unit
Drain Voltage	V_{DD}		10	V
Gate Voltage	V_{GG}		-3.0	V
Input Power	P_{in}		22	dBm
Storage Temperature	T_{stg}		-65 to +175	$^\circ\text{C}$
Operating Backside Temperature	T_{op}		-40 to +85	$^\circ\text{C}$

Eudyna recommends the following conditions for the long term reliable operation of GaAs FETs:

1. The drain-source operating voltage (V_{DD}) should not exceed 6 volts.
2. The forward and reverse gate currents should not exceed 4.0 and -0.33 mA respectively.
3. This product should be hermetically packaged

ELECTRICAL CHARACTERISTICS (Ambient Temperature $T_c=25^\circ\text{C}$)

Item	Symbol	Conditions	Limits			Unit
			Min.	Typ.	Max.	
Frequency Range	f	$V_{DD} = 6\text{V}$ $I_{DD} = 650\text{mA}$ (Typ.) $Z_S = Z_L = 50\Omega$	17.5 - 20.0			GHz
Output Power at 1 dB G.C.P.	P_{1dB}		29	31	-	dBm
Power Gain at 1 dB G.C.P.	G_{1dB}		16	21	26	dB
Drain Current	I_{ddrf}		-	700	950	mA
Power-Added Efficiency	η_{add}		-	30	-	%
Input Return Loss	RLi		-	-12	-	dB
Output Return Loss	RLo		-	-8	-	dB

Note: RF parameter sample size 10pcs./wafer. Criteria (accept/reject)=(0/1)

G.C.P.: Gain Compression Point

FMM5805X

17.5-20GHz Power Amplifier MMIC

P1dB, G1dB vs. FREQUENCY

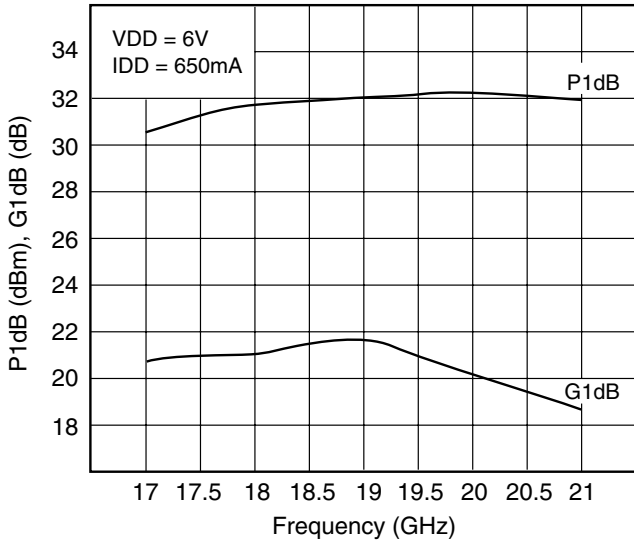

OUTPUT POWER vs. IMD

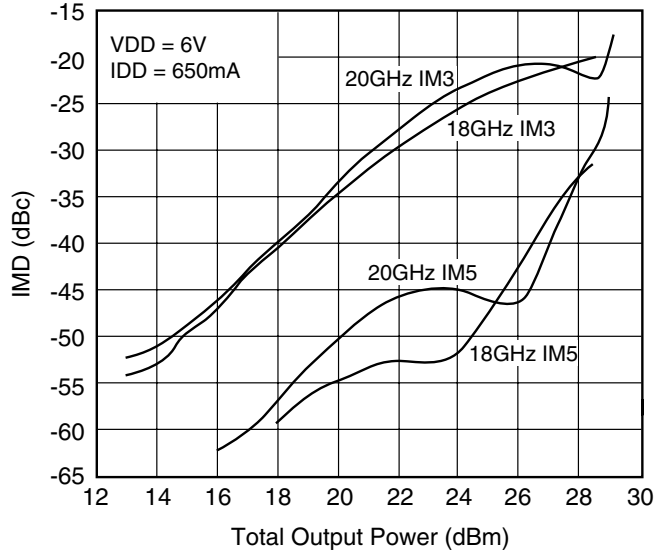

ASSEMBLY DRAWING

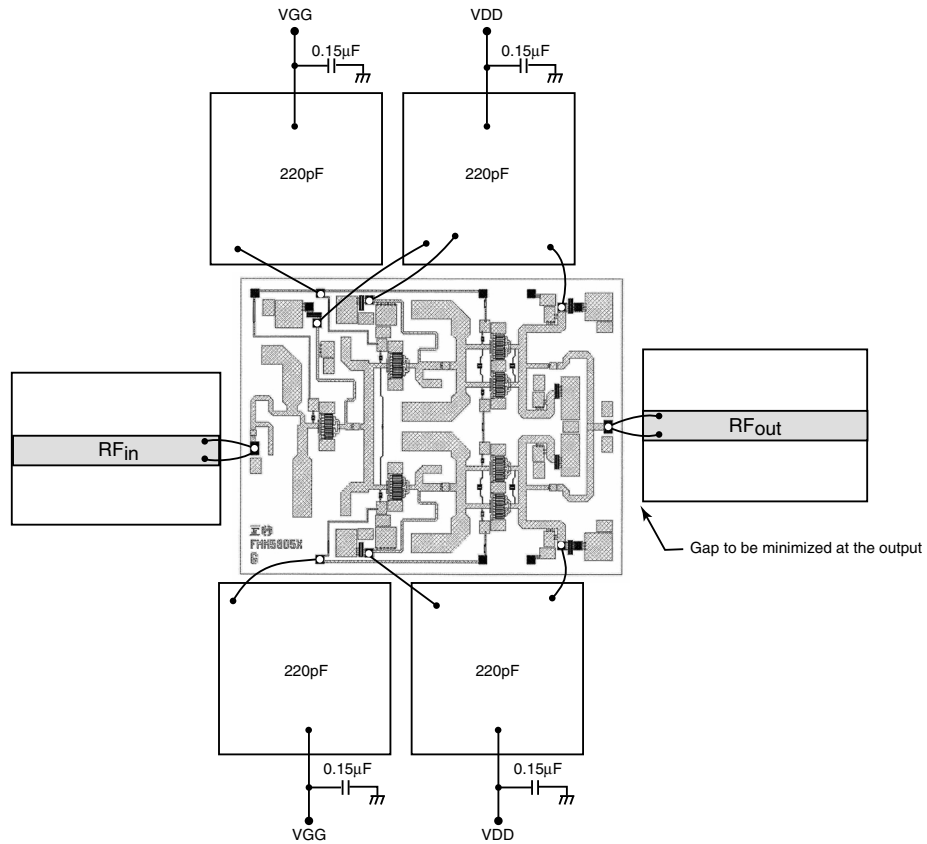

BONDING LAYOUT

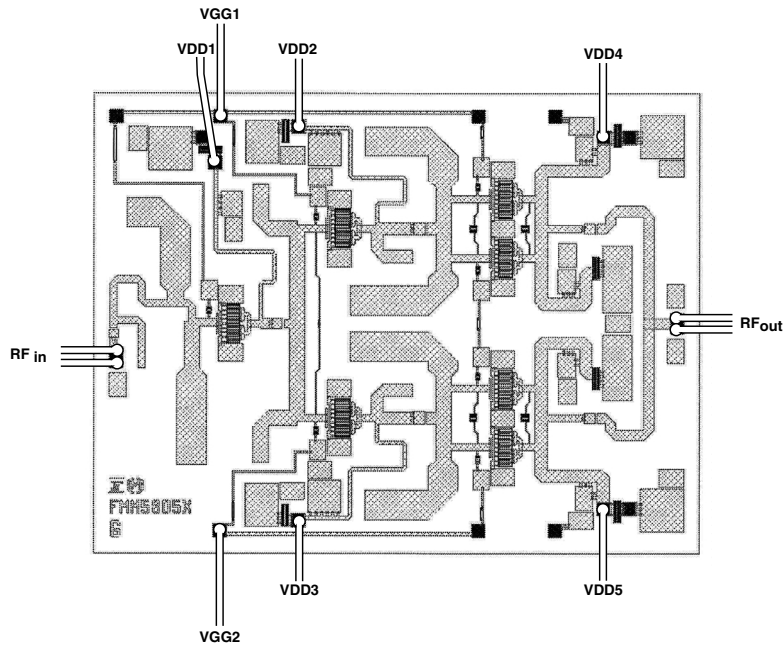

S-PARAMETERS

$V_{DD} = 6V, I_{DS} = 650mA$

FREQUENCY (MHZ)	S11		S21		S12		S22	
	MAG	ANG	MAG	ANG	MAG	ANG	MAG	ANG
14000	.672	144.5	3.454	165.4	.006	-90.6	.821	114.2
14500	.596	138.7	4.871	134.6	.006	-84.4	.754	102.2
15000	.502	133.1	7.047	106.3	.006	-90.4	.659	87.0
15500	.402	132.5	7.936	68.9	.008	-101.5	.536	67.3
16000	.297	136.1	11.029	28.2	.007	-95.3	.399	34.4
16500	.225	147.8	12.663	-13.5	.007	-96.5	.316	-19.3
17000	.212	169.1	12.727	-58.7	.008	-93.8	.357	-77.0
17500	.256	-172.7	12.061	-97.8	.008	-90.3	.471	-117.9
18000	.321	-169.9	11.271	-133.1	.009	-92.5	.555	-144.7
18500	.364	-169.8	10.470	-167.0	.010	-92.2	.585	-163.0
19000	.405	-172.0	10.272	159.4	.010	-100.8	.578	-178.4
19500	.440	-179.7	9.732	129.4	.010	-109.5	.533	170.5
20000	.458	173.4	9.580	92.7	.009	-107.3	.471	162.5
20500	.431	161.5	9.979	55.9	.007	-115.9	.388	156.4
21000	.328	145.7	10.109	14.0	.007	-110.0	.325	156.3
21500	.116	138.9	9.421	-36.9	.006	-91.9	.282	158.9
22000	.209	-112.3	7.116	-92.0	.007	-84.0	.224	165.0
22500	.457	-133.3	4.684	-139.4	.009	-73.9	.186	178.1
23000	.598	-154.3	2.873	176.7	.011	-77.9	.162	-165.7

FMM5805X

17.5-20GHz Power Amplifier MMIC

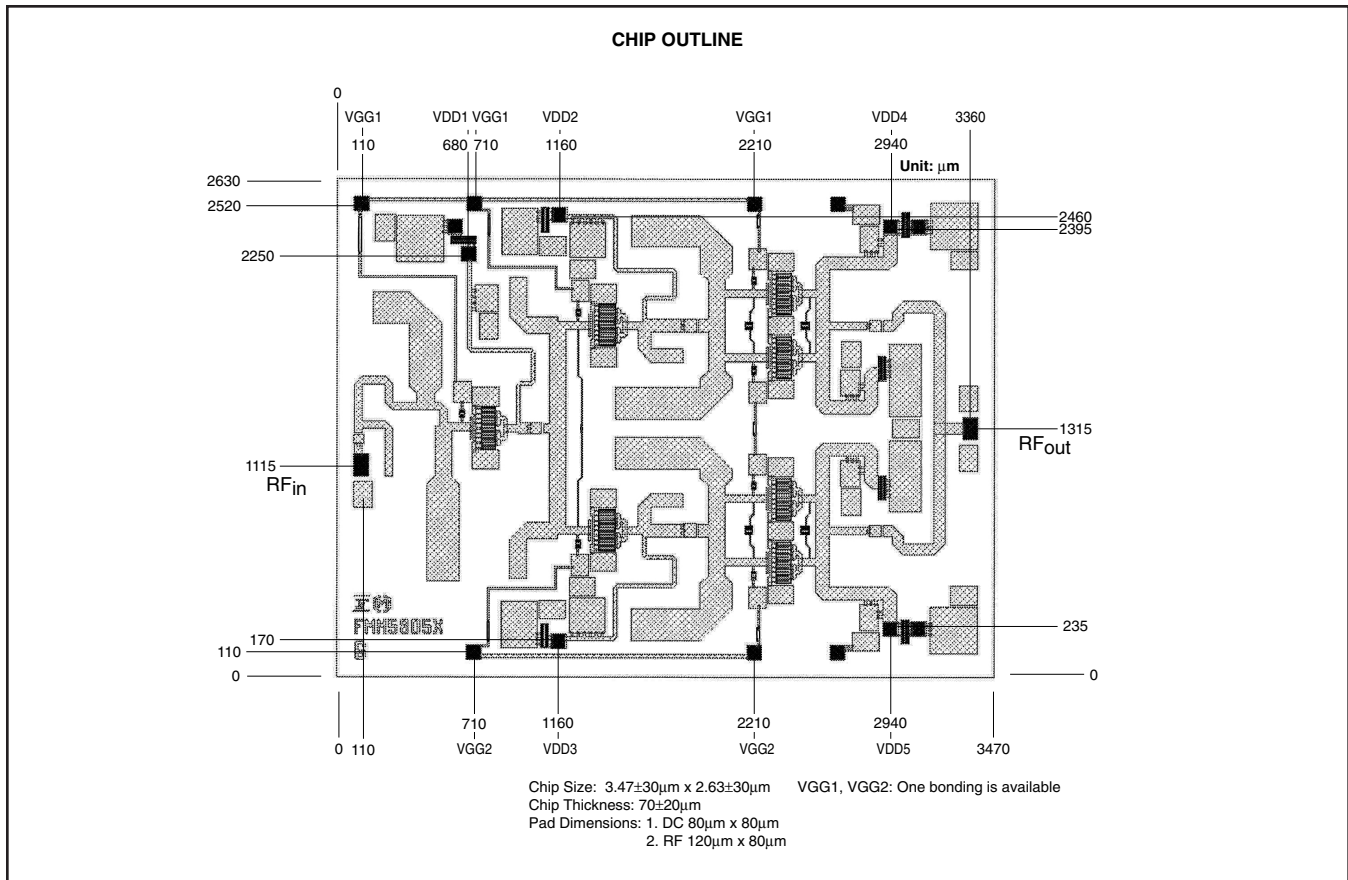

For further information please contact:

Eudyna Devices USA Inc.

2355 Zanker Rd.
San Jose, CA 95131-1138, U.S.A.
TEL: (408) 232-9500
FAX: (408) 428-9111
www.us.eudyna.com

Eudyna Devices Europe Ltd.

Network House
Norreys Drive
Maidenhead, Berkshire SL6 4FJ
United Kingdom
TEL: +44 (0) 1628 504800
FAX: +44 (0) 1628 504888

Eudyna Devices Asia Pte Ltd.

Hong Kong Branch
Rm. 1101, Ocean Centre, 5 Canton Rd.
Tsim Sha Tsui, Kowloon, Hong Kong
TEL: +852-2377-0227
FAX: +852-2377-3921

Eudyna Devices Inc.

Sales Division
1, Kanai-cho, Sakae-ku
Yokohama, 244-0845, Japan
TEL: +81-45-853-8156
FAX: +81-45-853-8170

CAUTION

Eudyna Devices Inc. products contain **gallium arsenide (GaAs)** which can be hazardous to the human body and the environment. For safety, observe the following procedures:

- Do not put this product into the mouth.
- Do not alter the form of this product into a gas, powder, or liquid through burning, crushing, or chemical processing as these by-products are dangerous to the human body if inhaled, ingested, or swallowed.
- Observe government laws and company regulations when discarding this product. This product must be discarded in accordance with methods specified by applicable hazardous waste procedures.

Eudyna Devices Inc. reserves the right to change products and specifications without notice. The information does not convey any license under rights of Eudyna Devices Inc. or others.

© 2004 Eudyna Devices USA Inc.
Printed in U.S.A.

Eudyna