

Features

- 电性能稳定
- 体积适中
- 通流能力大，抗冲击能力强
- 静态电容量小，绝缘性好
- 反应速度为50ns-150ns

Applications

- ADSL MODEM、FAX、TELEPHONE
- RS485、RS232、CAN一级防护
- CATV
- POWER电源防雷共模防护

产品尺寸/Dimensions (mm)

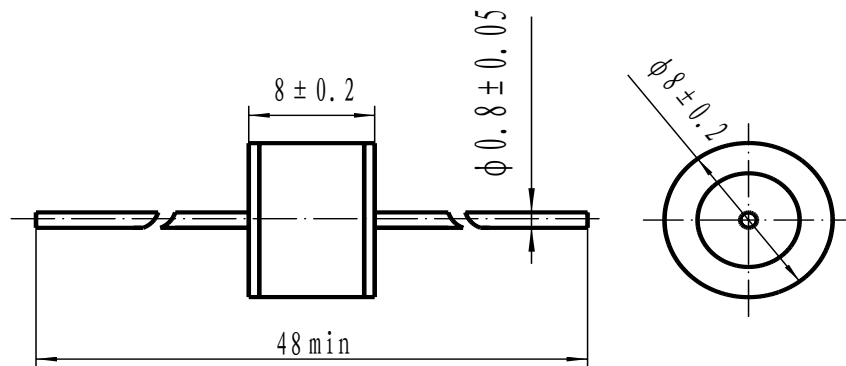

DIMENSIONS:MM

产品印字/Product Mark

Typical Part Marking



 B8L80R

产品命名/Product Name

B5

B5: 2R/5*5mm
B8: 2R/8*6mm
B8: 2R/8*10mm(HV)
C6: 3R/6*8mm
C7: 3R/7*11.5mm
C8: 3R/8*10mm

L

K: 3KA
L: 5KA
M: 10KA
H: 20KA

09

Nom. DC spark-over voltage Vs
09:90V
15:150V
47:470V
150:1500V

R

R: With Lead
Default: No Lead

X

Internal Code
(Default)
S:Fail-safe Card

Electrical Characteristics

Part Numbers	With Wire	B8L80R	B8L100R	B8L150R	B8L200R	B8L250R	B8K300R	B8K350R
	Without Wire	B8L80	B8L100	B8L150	B8L200	B8L250	B8K300	B8K350
DC Spark-over voltage Vs(@100V/S)(V)		800	1000	1500	2000	2500	3000	3500
Tolerance		±20%	±20%	±20%	±20%	±20%	±20%	±20%
Impulse spark-over voltage(@1KV/μS)(V)		≤1200	≤1400	≤2200	≤2800	≤3600	≤4200	≤5000
Nom. Impulse Discharge Current 10 time (@8/20μS)(KA)		5	5	5	5	5	3	3
AC Discharge Current (@50HZ/S) (A)		5	5	5	5	5	3	3
Insulation Resistance (@DC V) (GΩ)		>1	>1	>1	>1	>1	>1	>1
		250V	250V	500V	500V	500V	1000V	1000V
Capacitance (pF)		<1.5	<1.5	<1.5	<1.5	<1.5	<1.5	<1.5

包装说明/Packaging Specifications

Packaging: 100PCS Bulk

基本参数特性测试/Initial Characteristics

项目 Test Item	测试条件 Test Method	结果 Specification
直流放电电压 DC-Spark-Over Voltage Vs	使用一直流电源，并逐渐地增加测量电压，测试电流为1ma，测试时间最大为一秒 (1sec).(1mA)(Add and measure the DC Voltage gradually Maxto get the discharge threshold voltage. The measuring current is 1mA/1 second max.)	依规格书值而定 (It depends on each spec.)
内绝缘电阻 Insulation Resistance	在规定的设定直流电压下，跨在两端引线。即可测量其内绝缘电阻值。(Measure the insulation resistance of two end of leadwire under the specified DC voltage.)	大于等于100MΩ(100MΩ min.)
静态电容 Capacitance C(pF)	使用频率1KHz与并两端加载小于或等于6V直流电压的电源。即可量出其静态电容量Measure the Electrostatic Capacitance under the test condition of 1KHz,DC 6V(max).	小于或等于1.5pF (1.5pF max.)

环境试验测试/Environmental Characteristics

实验项目 Test Item	试验方法 Test Method	结果 Specification
耐寒性	放置于-40℃±3℃的环境中1000小时后，取出置于常温中4小时后，检测直流开始放电电压，绝缘阻抗，静态电容量及检查外。After -40±3℃ (1000hrs) / room temp.,normal humidity(4 hrs) cycle, measure the properties.	满足各个特性相关参数值 Within standard mentioned in Initial Characteristics.
耐热性	放置于125℃±2℃的环境中1000小时后，取出置于常温中4小时后，检测直流开始放电电压，绝缘阻抗，静态电容量及检查外。After 125±2℃ (1000hrs) / room temp.,normal humidity(4 hrs) cycle, measure the properties.	满足各个特性相关参数值 Within standard mentioned in Initial Characteristics.
耐温性	放置于85℃±2℃ RH85%的环境中1000小时后，取出置于常温中4小时后，检测直流开始放电电压，绝缘阻抗，静态电容量及检查外。After 85℃±2℃ RH85%(1000hrs) / room temp.,normal humidity(4 hrs) cycle, measure the properties.	满足各个特性相关参数值 Within standard mentioned in Initial Characteristics.
温度周期	-40℃±3℃ (30分)~(常温3分)~125℃±2℃ (30分)为1周期，重复25次后，取出置于常温/常温中4小时后，检测直流放电电压，绝缘阻抗，静态电容量及检查外观25 times repetition of cycle -40±3℃ (30 Min.),room temp., (4 Min.), 125±2℃(30 Min.),room temp., normal humidity(4hrs) .	满足各个特性相关参数值 Within standard mentioned in Initial Characteristics.

浪涌寿命测试/Surge Characteristics

实验项目 Test Item	试验方法 Test Method	结果Specification
浪涌承受能力	在陶瓷放电管置于8/20us的浪涌测试仪两端，施加该型号相对应的耐冲击电流，间隔时间为60s 正负各测试5次。检测其直流电压，绝缘阻抗，静态电容及检查外观	直流放电电流 $V_s/V_s \leq 30\%$ (DC spark-over volatage JSE: $\Delta V_s/V_s \leq 30\%$)
突波寿命测试	让一只陶瓷放电管与一只1500pF的电容并于电源两端，每间隔10秒施加10KV电压，做200次。(Apply 10 KV voltage charged in 1500pF condenser and apply the current to the specimen,200 times at 10 seconds of intervals.)	满足各个特性相关参数值 Within standard mentioned in Initial Characteristics.

环境试验测试/Enviromental Characteristics

实验项目 Test Item	试验方法 Test Method	结果Specification
拉力强度	施加2.5KG负重于引线约30秒钟后，检测直流放电电压，绝缘阻抗，静态电容及检查外观 (Apply 2.5 kgs load approximately 30 seconds, then check for pull-out and breaking of the lead wire.)	满足各个特性相关参数值 Within standard mentioned in Initial Characteristics.
弯曲强度	距离引线熔接点根部绝3mm处，使用曲率半径为0.75~0.8mm器具，与轴方向垂直角度，负重0.25Kg，弯曲后回复原状，反复2次后，检测直流放电电压，绝缘阻抗，静态电容及外观(Bend the lead wire, with jig which radius is 0.75~0.8mm, at the point of 2mm from the body, under 0.25 kgs load applied at the right angle the direction of the amis and get the bent lead wire back to its original poing after the procedure was repeated 2 times.)	满足各个特性相关参数值 Within standard mentioned in Initial Characteristics.

环境试验测试/Enviromental Characteristics

实验项目 Test Item	试验方法 Test Method	结果Specification
焊锡附着性	将沾过助焊剂之导线，自距离导线迷熔接点根部3mm处起，浸于 $265 \pm 5^\circ\text{C}$ 之焊锡液中5秒钟后，将导线之助焊剂洗净后，检查焊锡附着情况。(Apply flux and immerse in molten solder, up to the point of 3mm from the body,for 5 sec. ($235^\circ\text{C} \pm 5^\circ\text{C}$). Wash the leadwire and check for soldering adhesion.)	导线需均匀附着90%以上(Lead wire is evenly covered by solder over 90%.)
焊锡耐热性	将沾过助焊剂之导线，自距离导线迷熔接点根部3mm处起，浸于 $265 \pm 5^\circ\text{C}$ 之焊锡液中10秒钟后，检测直流放电电压，绝缘阻抗抗，静态电容及检查外观。(Apply flux and immerse in molten solder, up to the point of 3mm from the body,for 5 sec. ($235^\circ\text{C} \pm 5^\circ\text{C}$). Wash the leadwire and check for soldering adhesion.)	满足各个特性相关参数值 Within standard mentioned in Initial Characteristics.