

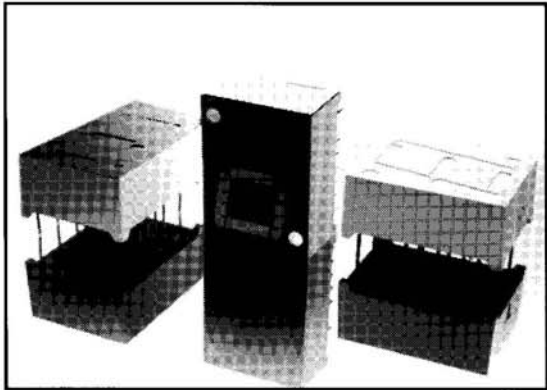

**DOUBLE HETEROJUNCTION
AlGaAs RED
LOW CURRENT DISPLAYS**

7.6mm (0.3in) MAN30X0A
14.2mm (0.56in) MAN60X0
20.0mm (0.8in) MAN80X0

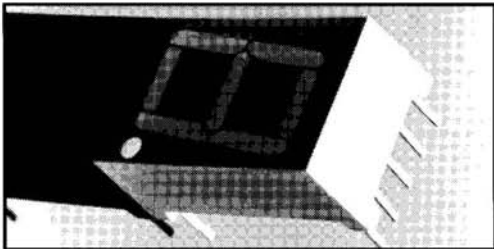
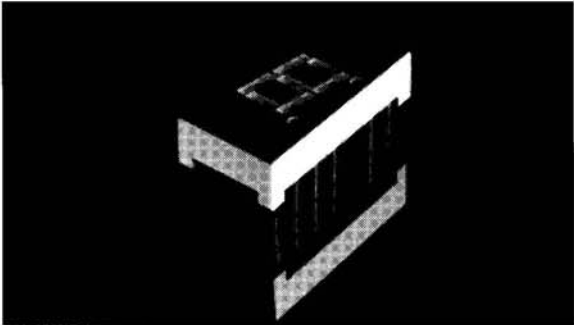

DESCRIPTION

This line of solid state LED displays uses newly developed Double Heterojunction (HD) AlGaAs/GaAs material to emit deep red light at 650 nm. This material has outstanding efficiency at low drive currents and can be either DC or pulse driven. Viewability at up to 10 meters (MAN8000 Series) is available for applications such as instruments weighing scales, meters and point-of-sale terminals.

FEATURES

- Low Power Consumption
Typical power consumption is 1.6mA/seg. at 1mA drive ideal for battery operated applications
- Typical intensity of 650 μ cd/seg at 1mA drive
- Excellent for multiplexing long digit strings
- Compatible with monolithic LED display drivers
- Three Character Sizes
7.6mm (0.3in), 14.2mm (0.56in), 20.0mm (0.8in)
- Common anode or common cathode
- Excellent character appearance
Wide viewing angle
Grey body for optimum contrast
- Categorized for luminous intensity. Use of like categorizes yields a uniform display

MODEL NUMBERS

PART NO.	CHARACTER SIZE	DESCRIPTION	PACKAGE DRAWING
MAN3010A	0.3" (7.6mm)	Common anode; right hand decimal	A
MAN3040A		Common cathode; right hand decimal	B
MAN3020A		Common anode; left hand decimal	C
MAN6060	0.56" (14.2mm)	Common anode; right hand decimal	D
MAN6080		Common cathode; right hand decimal	E
MAN8010	0.8" (20mm)	Common anode; right hand decimal	F
MAN8040		Common cathode; right hand decimal	G



**DOUBLE HETEROJUNCTION
AlGaAs RED
LOW CURRENT DISPLAYS**

ELECTRICAL/OPTICAL CHARACTERISTICS AT $T_A = 25^\circ\text{C}$							
DESCRIPTION	SYMBOL	DEVICE	TEST CONDITIONS	MIN.	TYP.	MAX.	UNITS
Luminous intensity/segment [1.2] (digit average)	I_v	MAN3000A Series	1 mA DC	315	600		μcd
			5 mA DC		3600		
			20 mA Pk: 1 of 4 Duty Factor		3300		
		MAN6000 Series	1 mA DC	400	700		μcd
			5 mA DC		4200		
			20 mA Pk: 1 of 4 Duty Factor		3900		
		MAN8000 Series	1 mA DC	270	500		μcd
			5 mA DC		3500		
			20 mA Pk: 1 of 4 Duty Factor		3300		
Peak wavelength	λ_{Peak}	All Devices			650		nm
Dominant wavelength [3]	λ_d	All Devices			642		nm
Forward voltage/segment or DP	V_f	All Devices	$I_f = 1 \text{ mA}$ $I_f = 5 \text{ mA}$ $I_f = 20 \text{ mA Pk}$		1.6 1.7 1.8	2.0 2.1 2.2	V
Reverse voltage/segment or DP	V_R	All Devices	$I_R = 100 \mu\text{A}$	3.0	15		V
Temp. coefficient of V_f /seg. or DP	$\Delta V_f/^\circ\text{C}$				-2mV		MV/°C
Thermal resistance LED junction— to—pin	R θ J-PIN	MAN3000 MAN6000 MAN8000			255 400 430		°C/W/Seg.

NOTES

1. Case temperature of the device immediately prior to the intensity measurement is 25°C.
2. The digits are categorized for luminous intensity with the intensity category designated by a letter on the side of the package.
3. The dominant wavelength, λ_d , is derived from the CIE chromaticity diagram and is that single wavelength which defines the color of the device.



**DOUBLE HETEROJUNCTION
AlGaAs RED
LOW CURRENT DISPLAYS**

ABSOLUTE MAXIMUM RATINGS (All Products)	
Average power per segment or DP ($T_A=25^\circ\text{C}$)	37 mW
Peak forward current per segment or DP ($T_A=25^\circ\text{C}$)[1]	45 mA
Average or DC forward current per segment or DP ($T_A=25^\circ\text{C}$)	15 mA
Operating temperature range	-20°C to $+85^\circ\text{C}$
Storage temperature range	-40°C to $+85^\circ\text{C}$
Reverse voltage per segment or DP	3.0 V
Lead solder temperature (1.59 mm [1/16"] below seating plane)	260°C for 3 sec.

NOTES: 1. Do not exceed maximum average current per segment.

NOTES
<p>1. The digit average Luminous Intensity is obtained by summing the Luminous Intensity of each segment and dividing by the total number of segments. Intensity will not vary more than $\pm 33.3\%$ between all segment within a digit.</p> <p>2. Leads of the device immersed to 1/16" from the body. Maximum device surface temperature is 140°C.</p> <p>3. For flux removal, Freon TF, Freon TE, Isoproponal or water may be used up to their boiling points.</p> <p>4. All displays are categorized for Luminous Intensity. The intensity category is marked on each part as a suffix letter to the part numbers.</p>

PACKAGE DIMENSIONS

MAN3000A SERIES

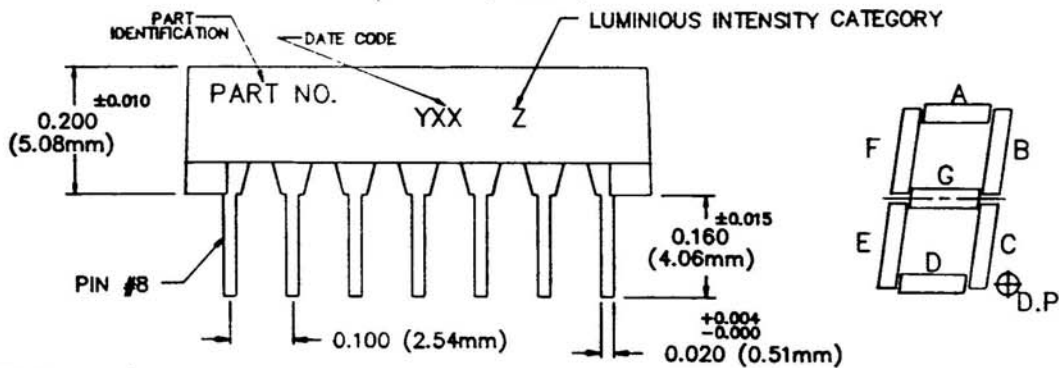
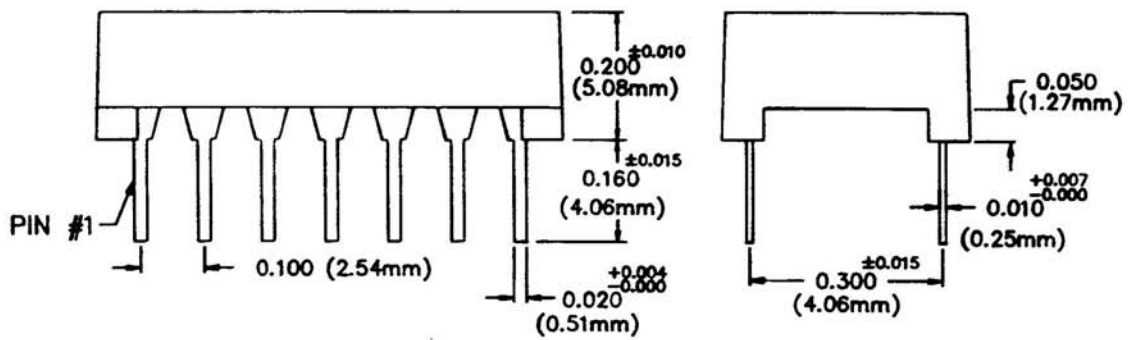
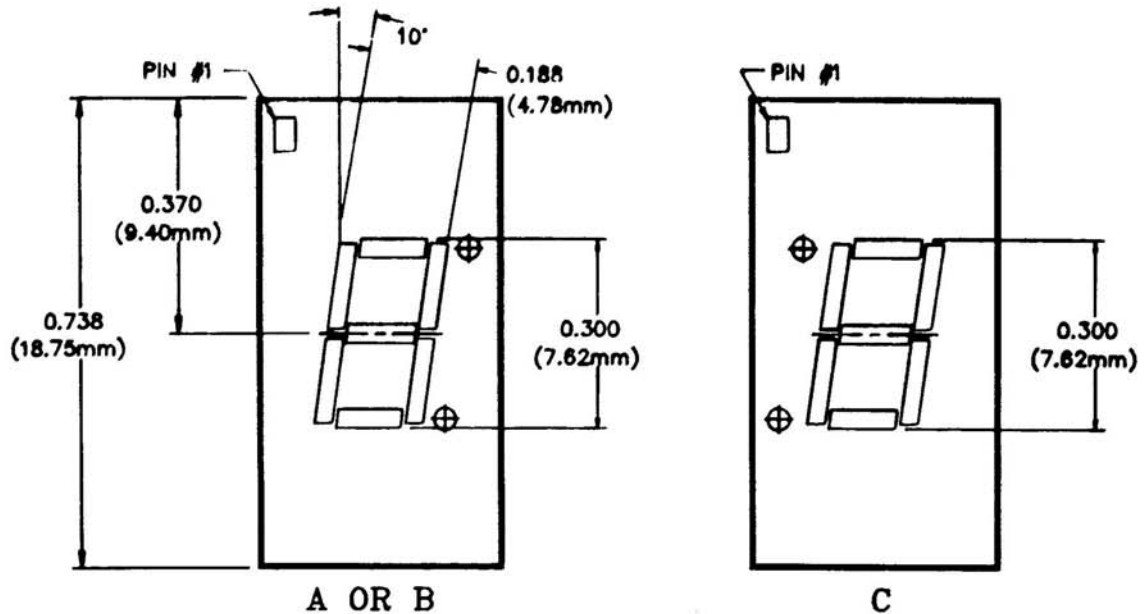

NOTE :
ALL DIMENSION ARE IN INCHES(mm)

C3060

PACKAGE DIMENSIONS

MAN6000 SERIES

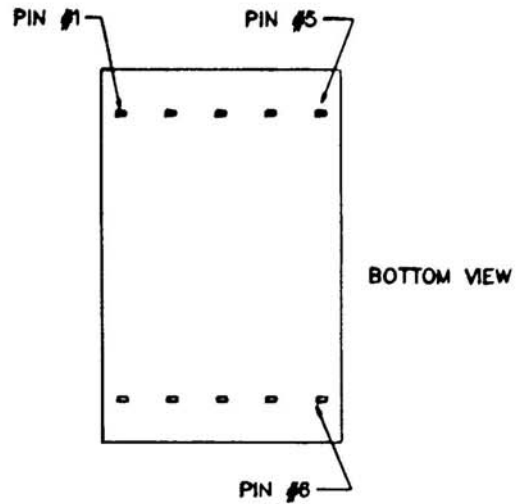
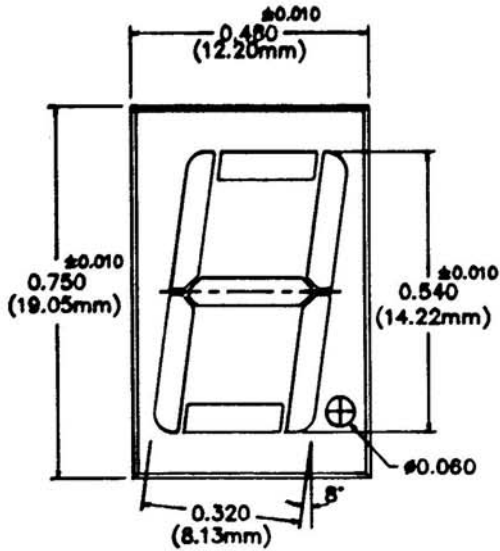

D OR E

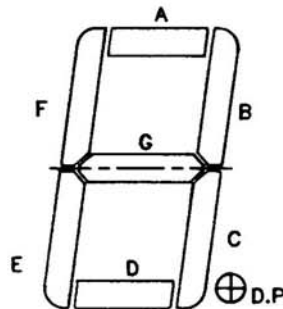
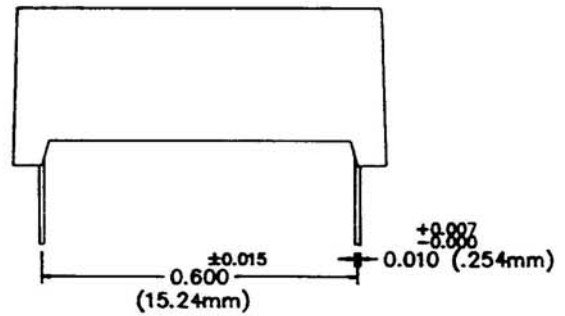
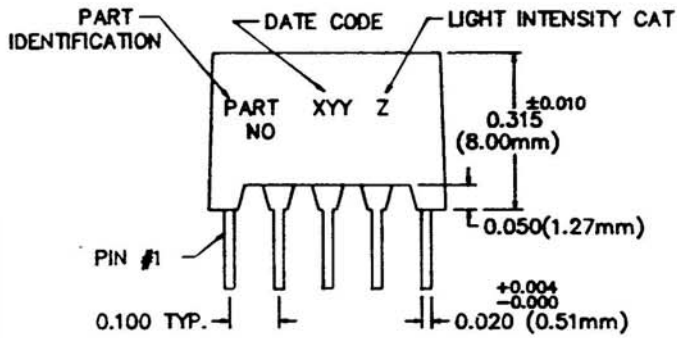



**DOUBLE HETEROJUNCTION
AlGaAs RED
LOW CURRENT DISPLAYS**

PACKAGE DIMENSIONS

MAN8000 SERIES

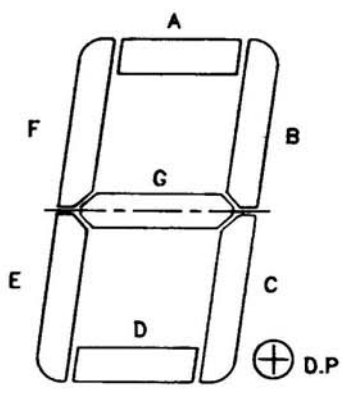
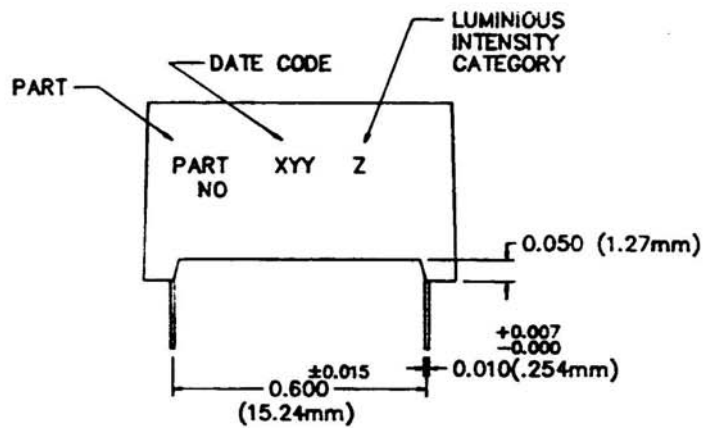
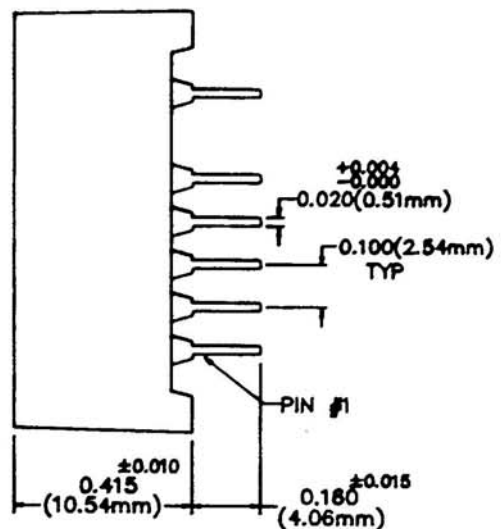
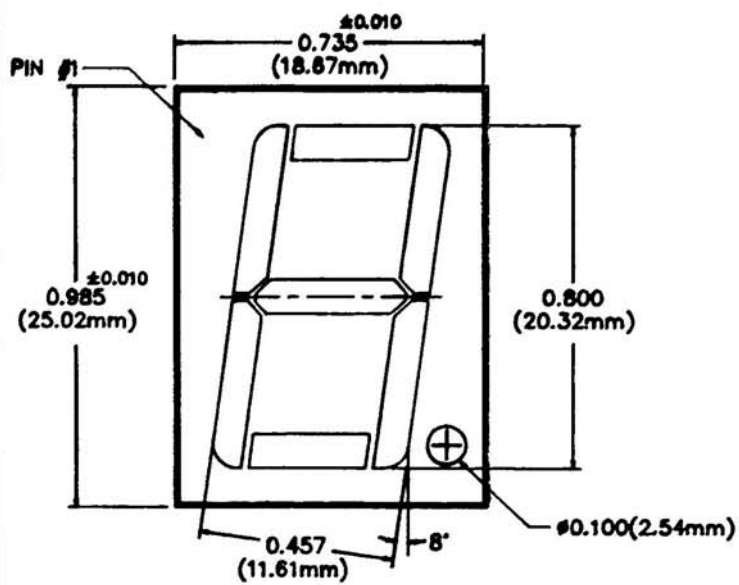

EVERLIGHT

DOUBLE HETEROJUNCTION AlGaAs RED LOW CURRENT DISPLAYS

ELECTRICAL CONNECTIONS

PIN NO.	A MAN3010A	B MAN3040A	C MAN3020A	D MAN6060	E MAN6080	F MAN8010	G MAN8040
1	Cathode A	Anode F	Cathode A	Cathode E	Anode E	No Connection	No Connection
2	Cathode F	Anode G	Cathode F	Cathode D	Anode D	A Cathode	A Anode
3	Common Anode	No Pin	Common Anode	Common Anode	Common Cathode	F Cathode	F Anode
4	No Pin	Common Cathode	No Pin	Cathode C	Anode C	Common Anode	Common Cathode
5	No Pin	No Pin	No Pin	Cathode D.P	Anode D.P	E Cathode	E Anode
6	No Connection	Anode E	Cathode D.P	Cathode B	Anode B	—	—
7	Cathode E	Anode D	Cathode E	Cathode A	Anode A	E Cathode	E Anode
8	Cathode D	Anode C	Cathode D	Common Anode	Common Cathode	—	—
9	Cathode D.P	Anode D.P	No Connection	Cathode F	Anode F	D Cathode	Common Cathode
10	Cathode C	No Pin	Cathode C	Cathode G	Anode G	D.P Cathode	D.P Anode
11	Cathode G	No Pin	Cathode G			D Cathode	D Anode
12	No Pin	Common Cathode	No Pin			Common Anode	Common Cathode
13	Cathode B	Anode B	Cathode B			C Cathode	C Anode
14	Common Anode	Anode A	Common Anode			G Cathode	G Anode
15						B Cathode	B Anode
16						—	—
17						Common Anode	Common Cathode
18						—	—

ELECTRICAL SCHEMATIC

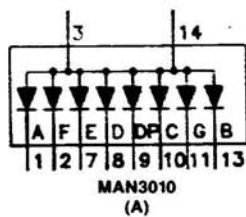

C3070

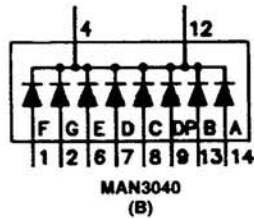

C3071

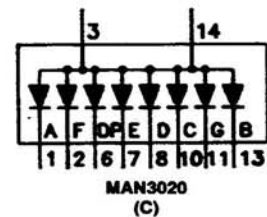

C3072

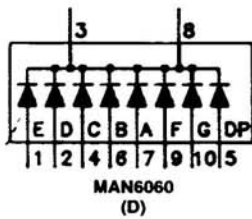

C3073

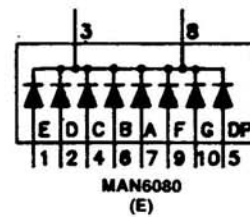

C3074

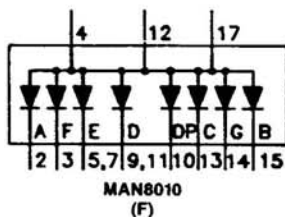

C3075

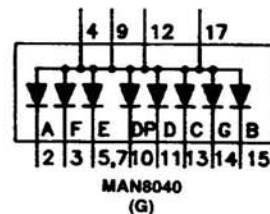

C3076



**DOUBLE HETEROJUNCTION
AlGaAs RED
LOW CURRENT DISPLAYS**

DISCLAIMER

FAIRCHILD SEMICONDUCTOR RESERVES THE RIGHT TO MAKE CHANGES WITHOUT FURTHER NOTICE TO ANY PRODUCTS HEREIN TO IMPROVE RELIABILITY, FUNCTION OR DESIGN. FAIRCHILD DOES NOT ASSUME ANY LIABILITY ARISING OUT OF THE APPLICATION OR USE OF ANY PRODUCT OR CIRCUIT DESCRIBED HEREIN; NEITHER DOES IT CONVEY ANY LICENSE UNDER ITS PATENT RIGHTS, NOR THE RIGHTS OF OTHERS.

LIFE SUPPORT POLICY

FAIRCHILD'S PRODUCTS ARE NOT AUTHORIZED FOR USE AS CRITICAL COMPONENTS IN LIFE SUPPORT DEVICES OR SYSTEMS WITHOUT THE EXPRESS WRITTEN APPROVAL OF THE PRESIDENT OF FAIRCHILD SEMICONDUCTOR CORPORATION. As used herein:

1. Life support devices or systems are devices or systems which, (a) are intended for surgical implant into the body, or (b) support or sustain life, and (c) whose failure to perform when properly used in accordance with instructions for use provided in the labeling, can be reasonably expected to result in a significant injury of the user.
2. A critical component in any component of a life support device or system whose failure to perform can be reasonably expected to cause the failure or to of the life support device or system, or to affect its safety or effectiveness.

