

Voltage Detector IC Series

Counter Timer Built-in CMOS Voltage Detector IC

BD45□□□G, BD46□□□G series



●General Description

ROHM's BD45□□□G and BD46□□□G series are highly accurate, low current consumption reset IC series. Because the counter timer delay circuit is built into those series, an external capacitor for the delay time setting is unnecessary. The lineup was established with tow output types (Nch open drain and CMOS output) and detection voltages range from 2.3V to 4.8V in increments of 0.1V, so that the series may be selected according the application at hand.

●Features

- 1) Detection voltage: 2.3V to 4.8V (Typ.), 0.1V steps
- 2) High accuracy detection voltage: $\pm 1.0\%$
- 3) Ultra-low current consumption: $0.85 \mu A$ (Typ.)
- 4) Three internal, fixed delay time: 50 msec, 100 msec and 200 msec
- 5) Nch open drain output (BD45□□□G), CMOS output (BD46□□□G)
- 6) SSOP5 compact surface mount packages
- 7) Operating temperature range: $-40^{\circ}C$ to $+105^{\circ}C$

●Applications

All electronic devices that use microcontrollers and logic circuits

●Selection Guide

Part Number : BD4□□□G

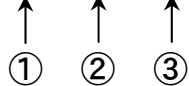

Number	Specifications	Description
①	Output Circuit Format	2: Open Drain Output 3: CMOS Output
②	Detection Voltage	Example: Displays VDET over a 2.3V to 4.8V range in 0.1V increments. (2.9V is marked as "29")
③	Fixed Delay Times	5: 50msec(Typ.) 1: 100msec(Typ.) 2: 200msec(Typ.)

●Lineup

Detection Voltage	Marking	Part Number	Marking	Part Number	Marking	Part Number	Marking	Part Number	Marking	Part Number	Marking	Part Number
4.8V	T0	BD45485	TS	BD45481	UJ	BD45482	VA	BD46485	W2	BD46481	WU	BD46482
4.7V	T1	BD45475	TT	BD45471	UK	BD45472	VB	BD46475	W3	BD46471	WV	BD46472
4.6V	T2	BD45465	TU	BD45461	UL	BD45462	VC	BD46465	W4	BD46461	WW	BD46462
4.5V	T3	BD45455	TV	BD45451	UM	BD45452	VD	BD46455	W5	BD46451	WX	BD46452
4.4V	T4	BD45445	TW	BD45441	UN	BD45442	VE	BD46445	W6	BD46441	WY	BD46442
4.3V	T5	BD45435	TX	BD45431	UP	BD45432	VF	BD46435	W7	BD46431	WZ	BD46432
4.2V	T6	BD45425	TY	BD45421	UQ	BD45422	VG	BD46425	W8	BD46421	X0	BD46422
4.1V	T7	BD45415	TZ	BD45411	UR	BD45412	VH	BD46415	W9	BD46411	X1	BD46412
4.0V	T8	BD45405	U0	BD45401	US	BD45402	VJ	BD46405	WA	BD46401	X2	BD46402
3.9V	T9	BD45395	U1	BD45391	UT	BD45392	VK	BD46395	WB	BD46391	X3	BD46392
3.8V	TA	BD45385	U2	BD45381	UU	BD45382	VL	BD46385	WC	BD46381	X4	BD46382
3.7V	TB	BD45375	U3	BD45371	UV	BD45372	VM	BD46375	WD	BD46371	X5	BD46372
3.6V	TC	BD45365	U4	BD45361	UW	BD45362	VN	BD46365	WE	BD46361	X6	BD46362
3.5V	TD	BD45355	U5	BD45351	UX	BD45352	VP	BD46355	WF	BD46351	X7	BD46352
3.4V	TE	BD45345	U6	BD45341	UY	BD45342	VQ	BD46345	WG	BD46341	X8	BD46342
3.3V	TF	BD45335	U7	BD45331	UZ	BD45332	VR	BD46335	WH	BD46331	X9	BD46332
3.2V	TG	BD45325	U8	BD45321	V0	BD45322	VS	BD46325	WJ	BD46321	XA	BD46322
3.1V	TH	BD45315	U9	BD45311	V1	BD45312	VT	BD46315	WK	BD46311	XB	BD46312
3.0V	TJ	BD45305	UA	BD45301	V2	BD45302	VU	BD46305	WL	BD46301	XC	BD46302
2.9V	TK	BD45295	UB	BD45291	V3	BD45292	VV	BD46295	WM	BD46291	XD	BD46292
2.8V	TL	BD45285	UC	BD45281	V4	BD45282	VW	BD46285	WN	BD46281	XE	BD46282
2.7V	TM	BD45275	UD	BD45271	V5	BD45272	VX	BD46275	WP	BD46271	XF	BD46272
2.6V	TN	BD45265	UE	BD45261	V6	BD45262	JY	BD46265	WQ	BD46261	XG	BD46262
2.5V	TP	BD45255	UF	BD45251	V7	BD45252	JZ	BD46255	WR	BD46251	XH	BD46252
2.4V	TQ	BD45245	UG	BD45241	V8	BD45242	W0	BD46245	WS	BD46241	XJ	BD46242
2.3V	TR	BD45235	UH	BD45231	V9	BD45232	W1	BD46235	WT	BD46231	XK	BD46232

● Absolute Maximum Rating (Ta=25°C)

Parameter		Symbol	Limits	Unit
Power Supply Voltage		VDD-GND	-0.3 ~ +10	V
Output Voltage	Nch Open Drain Output	VOUT	GND-0.3 ~ +10	V
	CMOS Output		GND-0.3 ~ VDD+0.3	
ER pin Voltage		VCT	GND-0.3 ~ VDD+0.3	V
Power Dissipation		Pd	540	mW
Operating Temperature		Topr	-40 ~ +105	°C
Ambient Storage Temperature		Tstg	-55 ~ +125	°C

*1 Use above Ta=25°C results in a 5.4mW loss per degree.

*2 When mounted on a 70mm × 70mm × 1.6mm glass epoxy board.

● Electrical Characteristics (Unless specified otherwise, Ta=-25°C~+105°C)

Parameter	Symbol	Min.	Typ.	Max.	Unit	Conditions	
Detection Voltage	*1 VDET	VDET(T) × 0.99	VDET (T)	VDET(T) × 1.01	V	VDD=H→L, RL=470kΩ	
Detection Voltage Temperature Coefficient	VDET/ΔT	—	±100	±360	ppm/°C	Ta=-25°C~+105°C (Designed Guarantee)	
Hysteresis Voltage	ΔVDET	VDET × 0.03	VDET × 0.05	VDET × 0.08	V	RL=470kΩ, VDD=L→H→L	
Circuit Current at ON	*1 IDD1	—	0.80	2.40	μA	VDD=VDET-0.2V, VDET=4.3~4.8V	
Circuit Current at OFF	*1 IDD2	—	0.85	2.55	μA	VDD=VDET+2.0V, VDET=4.3~4.8V	
Operating Voltage Range	VOPL	0.95	—	—	V	RL=470kΩ, VOL ≥ 0.4V, Ta=25~105°C	
“Low” Output Current	IOL	2.0	5.0	—	mA	VDS=0.5V, VDD=2.4V, VDET ≥ 2.7V	
“High” Output Current	*1 IOH	1.2	2.7	—	mA	VDS=0.5V, VDD=6.0V, VDET ≥ 4.3V	
“H” Transmission Delay Time	*1 *2 tPLH	45	50	55	msec	RL=100kΩ CL=100pF	BD45XX5G, BD46XX5G
		90	100	110			BD45XX1G, BD46XX1G
		180	200	220			BD45XX2G, BD46XX2G

*1 Guarantee on Ta=25°C

*2 tPLH: VDD = (VDET(T)-0.5) → (VDET(T)+0.5)

Designed Guarantee. (Outgoing inspection is not done on all products.)

● Block Diagrams

BD45□□□G

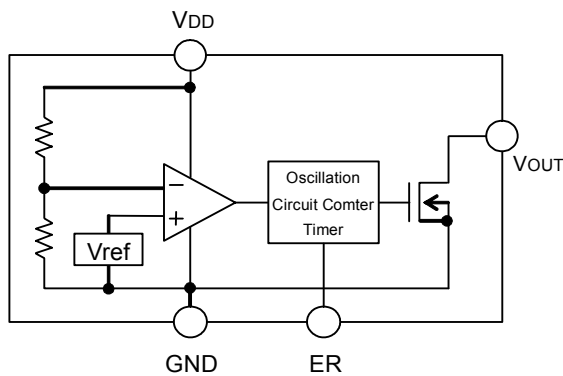

Fig.1

BD46□□□G

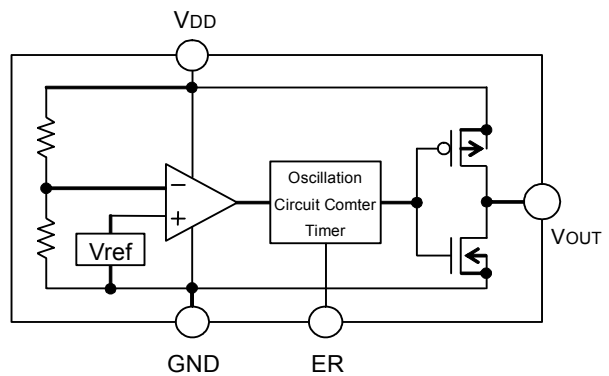

Fig.2

TOP VIEW



SSOP5

PIN No.	Symbol	Function
1	ER	Manual Reset
2	SUB	Substrate *
3	GND	GND
4	VOUT	Reset Output
5	VDD	Power Supply Voltage

*Connect the substrate to GND.

● Reference Data (Unless specified otherwise, $T_a=25^\circ\text{C}$)

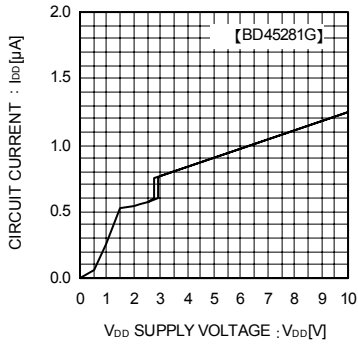

Fig.3 Circuit Current

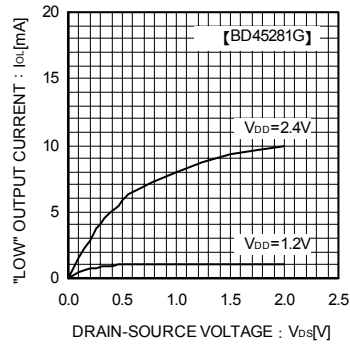

Fig.4 "Low" Output Current

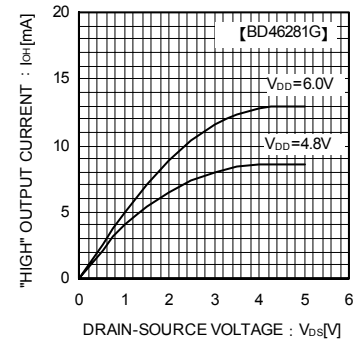

Fig.5 "High" Output Current

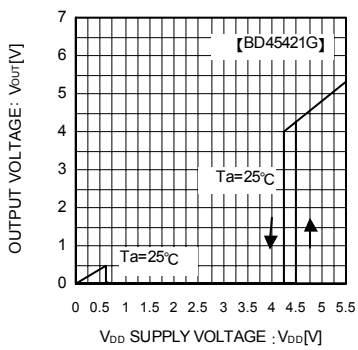

Fig.6 I/O Characteristics

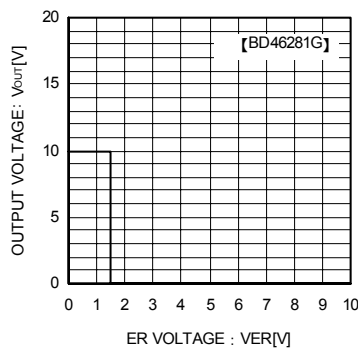

Fig.7 ER Terminal Threshold Voltage

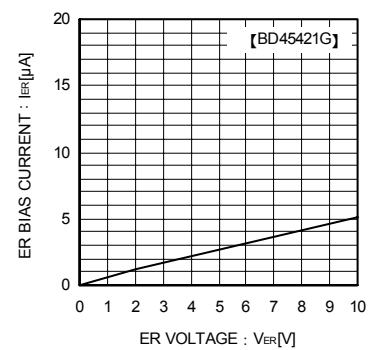

Fig.8 ER Terminal Input Current

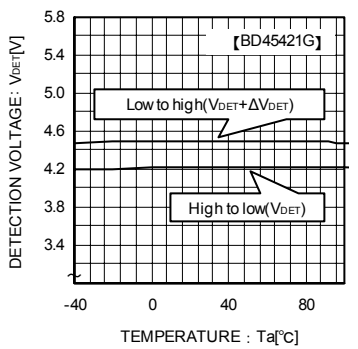

Fig.9 Detection Voltage Release Voltage

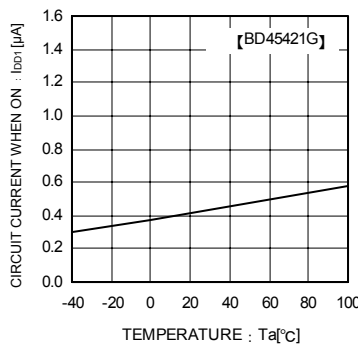

Fig.10 Circuit Current when ON (VDET-0.2V)

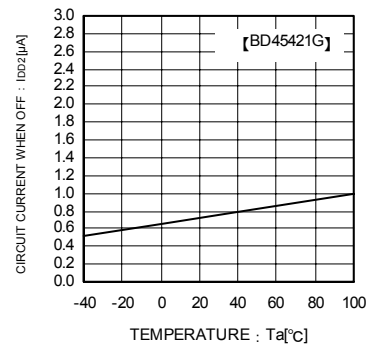

Fig.11 Circuit Current when OFF

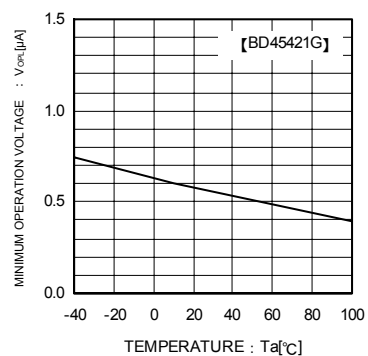

Fig.12 Operating Limit Voltage

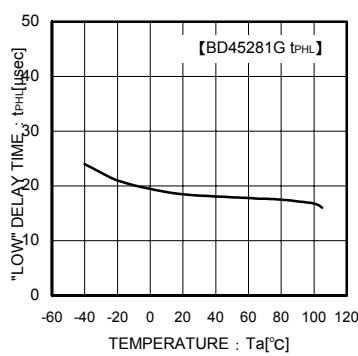

Fig.13 Output Delay Time "Low" → "High"

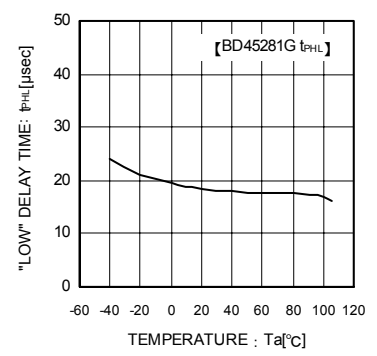

Fig.14 Output Delay Time "High" → "Low"

●Reference Data

Examples of Leading (TPLH) and Falling (TPHL) Output

Part Number	tPLH[ms]	tPHL[μs]
BD45275G	50	18
BD46275G	50	18

V_{DD}=2.2V→3.2V

V_{DD}=3.2V→2.2V

*This data is for reference only.

The figures will vary with the application, so please confirm actual operating conditions before use.

●Explanation of Operation

For both the open drain type (Fig. 15) and the CMOS output type (Fig. 16), the detection and release voltages are used as threshold voltages. When the voltage applied to the VDD pins reaches the applicable threshold voltage, the VOUT terminal voltage switches from either “High” to “Low” or from “Low” to “High”. Because the BD45□□□G series uses an open drain output type, it is possible to connect a pull-up resistor to VDD or another power supply [The output “High” voltage (VOUT) in this case becomes VDD or the voltage of the other power supply].

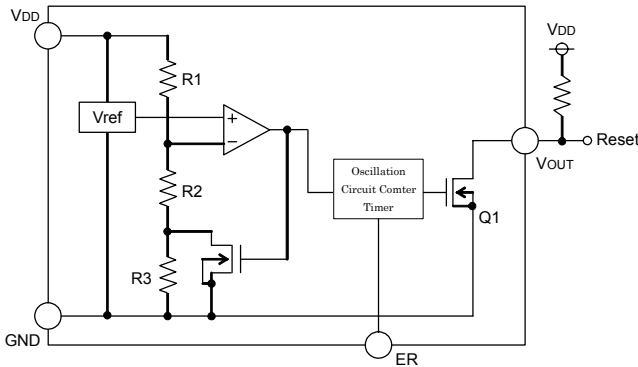

Fig.15 (BD45□□□G Type Internal Block Diagram)

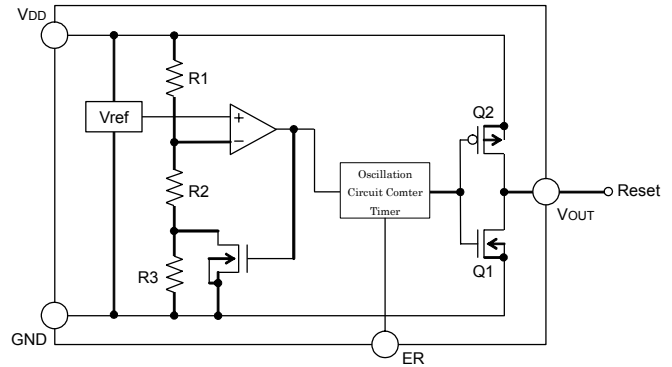

Fig.16 (BD46□□□G Type Internal Block Diagram)

●Timing Waveform

Example: the following shows the relationship between the input voltages VDD, the output voltage VOUT and ER terminal when the input power supply voltage VDD is made to sweep up and sweep down (the circuits are those in Fig. 12 and 13).

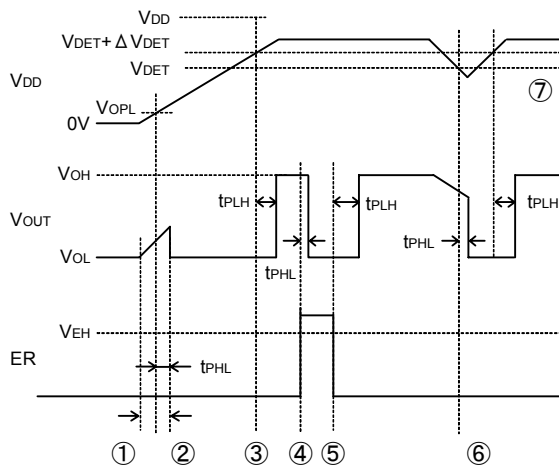

Fig.17

- ① When the power supply is turned on, the output is unsettled from after over the operating limit voltage (VOPL) until TPHL. Therefore it is possible that the reset signal is not outputted when the rise time of VDD is faster than TPHL.
- ② When VDD is greater than VOPL but less than the reset release voltage (VDET + ΔVDET), the output voltages will switch to Low.
- ③ If VDD exceeds the reset release voltage (VDET + ΔVDET), the counter timer start and VOUT switches from L to H.
- ④ When more than the high level voltage is supplied ER terminal, VOUT comes to “L” after tPLH delay time. Therefore, a time when ER terminal is “H” is necessary for 100 μsec or more.
- ⑤ When the ER terminal switches to Low, the counter timer starts to operate, a delay of tPLH occurs, and VOUT switches from “L” to “H”.
- ⑥ If VDD drops below the detection voltage (VDET) when the power supply is powered down or when there is a power supply fluctuation, VOUT switches to L (with a delay of tPHL).
- ⑦ The potential difference between the detection voltage and the release voltage is known as the hysteresis width (ΔVDET). The system is designed such that the output does not flip-flop with power supply fluctuations within this hysteresis width, preventing malfunctions due to noise.

These time changes by the application and use it, please verify and confirm using practical applications.

●Circuit Applications

1) Examples of a common power supply detection reset circuit.

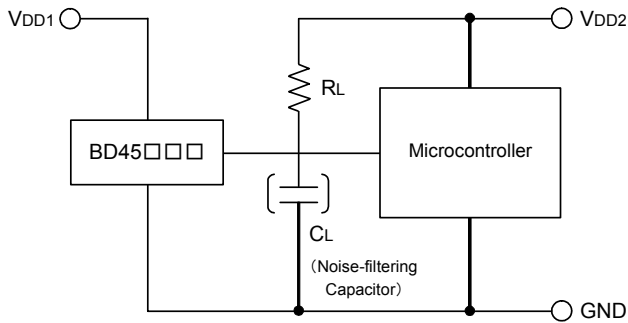

Fig.18 Open Collector Output Type

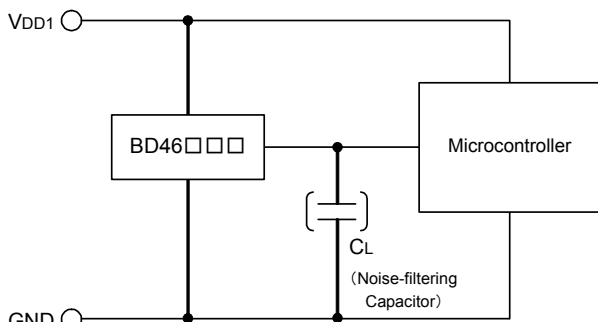

Fig.19 CMOS Output Type

Application examples of BD45 series (Open Drain output type) and BD46 series (CMOS output type) are shown below.

CASE1: the power supply of the microcontroller (VDD2) differs from the power supply of the reset detection (VDD1). Use the open drain output type (BD45 series) attached a load resistance (RL) between the output and VDD2. (As shown Figure 18)

CASE2: the power supply of the microcontroller (VDD1) is same as the power supply of the reset detection (VDD1). Use CMOS output type (BD46 series) or open drain output type (BD45 series) attached a load resistance (RL) between the output and VDD1. (As shown Figure 19)

When a capacitance CL for noise filtering is connected to the VOUT pin (the reset signal input terminal of the microcontroller), please take into account the waveform of the rise and fall of the output voltage (VOUT).

2) The following is an example of a circuit application in which an OR connection between two types of detection voltages resets the microcontroller.

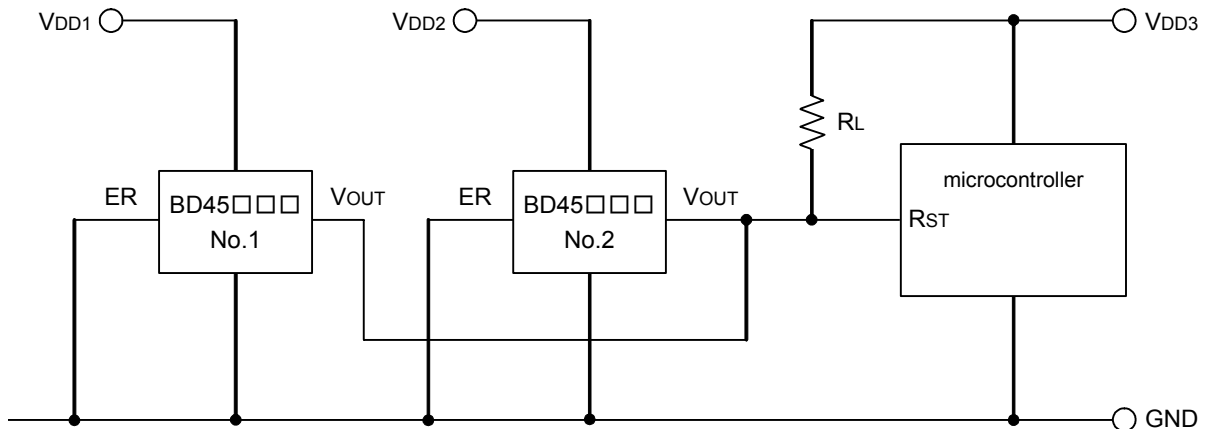

Fig.20

When there are many power supplies of the system, power supplies VDD1 and VDD2 are being monitored separately, and it is necessary to reset the microcomputer, it is possible to use an OR connection on the open drain output type BD45 series to pull-up to the desired voltage (VDD3) as shown in Fig. 20 and make the output "High" voltage matches the power supply voltage VDD3 of the microcontroller.

Examples of the power supply with resistor dividers

In applications where the power supply input terminal (VDD) of an IC with resistor dividers, it is possible that a through current will momentarily flow into the circuit when the output logic switches, resulting in malfunctions (such as output oscillatory state). (Through-current is a current that momentarily flows from the power supply (VDD) to ground (GND) when the output level switches from "High" to "Low" or vice versa.)

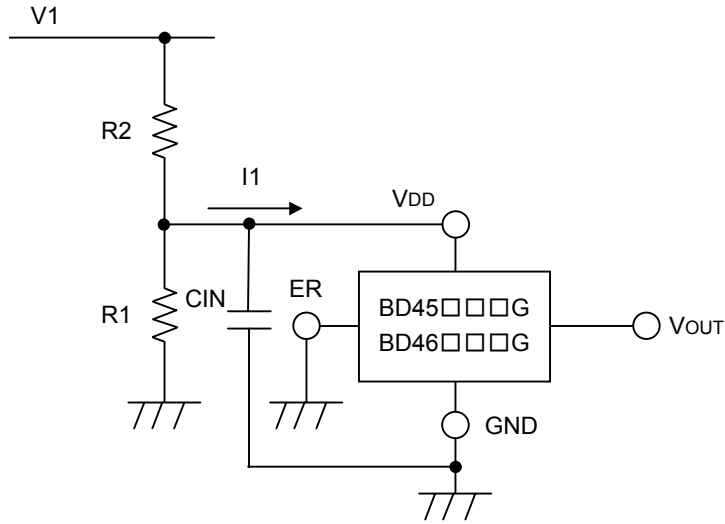

Fig.21

A voltage drop of $[I1] \times [R2]$ is caused by the through current, and the input voltage to the IC descends. When the output switches from "Low" to "High". When the input voltage decreases and falls below the detection voltage, the output voltage switches from "High" to "Low". At this time, the through-current stops flowing through output "Low", and the voltage drop is eliminated. As a result, the output switches from "Low" to "High", which again causes the through current to flow and the voltage drop. This process is repeated, resulting in oscillation.

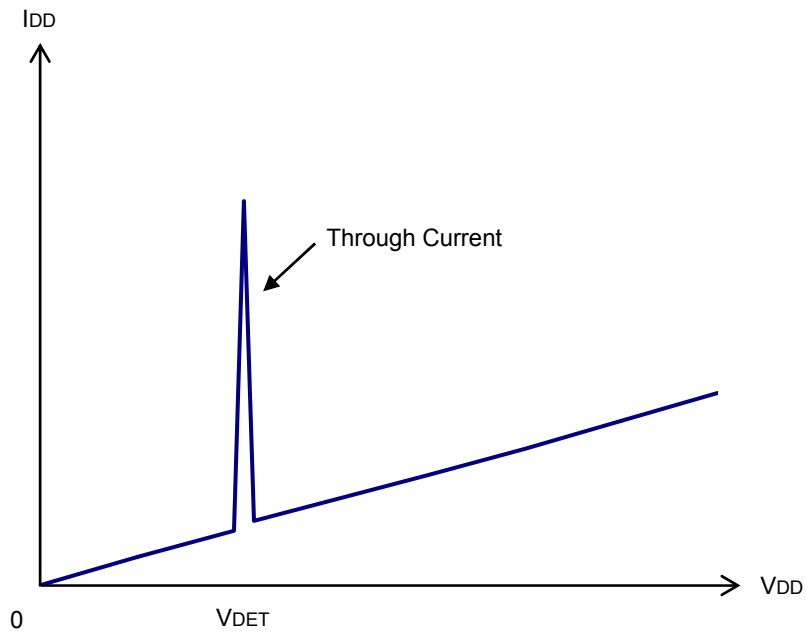

Fig.22 Current Consumption vs. Power Supply Voltage

● Operation Notes

1 . Absolute maximum range

Absolute Maximum Ratings are those values beyond which the life of a device may be destroyed. We cannot be defined the failure mode, such as short mode or open mode. Therefore a physical security countermeasure, like fuse, is to be given when a specific mode to be beyond absolute maximum ratings is considered.

2 . GND potential

GND terminal should be a lowest voltage potential every state.

Please make sure all pins, which are over ground even if, include transient feature.

3 . Electrical Characteristics

Be sure to check the electrical characteristics that are one the tentative specification will be changed by temperature, supply voltage, and external circuit.

4 . Bypass Capacitor for Noise Rejection

Please put into the capacitor of $1\ \mu\text{F}$ or more between VDD pin and GND, and the capacitor of about 1000pF between VOUT pin and GND, to reject noise. If extremely big capacitor is used, transient response might be late. Please confirm sufficiently for the point.

5 . Short Circuit between Terminal and Soldering

Don't short-circuit between Output pin and VDD pin, Output pin and GND pin, or VDD pin and GND pin. When soldering the IC on circuit board, please be unusually cautious about the orientation and the position of the IC. When the orientation is mistaken the IC may be destroyed.

6 . Electromagnetic Field

Mal-function may happen when the device is used in the strong electromagnetic field.

7 . The VDD line impedance might cause oscillation because of the detection current.

8 . A VDD -GND capacitor (as close connection as possible) should be used in high VDD line impedance condition.

9 . Lower than the minimum input voltage makes the VOUT high impedance, and it must be VDD in pull up (VDD) condition.

10. This IC has extremely high impedance terminals. Small leak current due to the uncleanness of PCB surface might cause unexpected operations. Application values in these conditions should be selected carefully. If the leakage of about $1\text{M}\Omega$ is assumed between the ER terminal and the GND terminal, $100\text{k}\Omega$ connection between the ER terminal and the VDD terminal would be recommended. If the leakage is assumed between the VOUT terminal and the GND terminal, the pull-up resistor should be less than 1/10 of the assumed leak resistance.

11. External parameters

The recommended parameter range for R_L is $50\text{k}\Omega \sim 1\text{M}\Omega$. There are many factors (board layout, etc) that can affect characteristics. Please verify and confirm using practical applications.

12. Power on reset operation

Please note that the power on reset output varies with the VDD rise up time. Please verify the actual operation.

13. Precautions for board inspection

Connecting low-impedance capacitors to run inspections with the board may produce stress on the IC. Therefore, be certain to use proper discharge procedure before each process of the test operation.

To prevent electrostatic accumulation and discharge in the assembly process, thoroughly ground yourself and any equipment that could sustain ESD damage, and continue observing ESD-prevention procedures in all handling, transfer and storage operations. Before attempting to connect components to the test setup, make certain that the power supply is OFF. Likewise, be sure the power supply is OFF before removing any component connected to the test setup.

14. When the power supply, is turned on because of in certain cases, momentary Rash-current flow into the IC at the logic unsettled, the couple capacitance, GND pattern of width and leading line must be considered.

● Part Number Selection

B	D	4			G	-	T	R
BD45: Open Drain Type CMOS Detector IC with Built-In Counter Timer BD46: CMOS Output Type CMOS Detector IC with Built-In Counter Timer				Reset Voltage Value 23: 2.3V 48: 4.8V	Counter Timer Delay Time Settings 5: 50msec 1: 100msec 2: 200msec	Package G: SSOP5	Taping Specifications Embossed Taping	

SSOP5

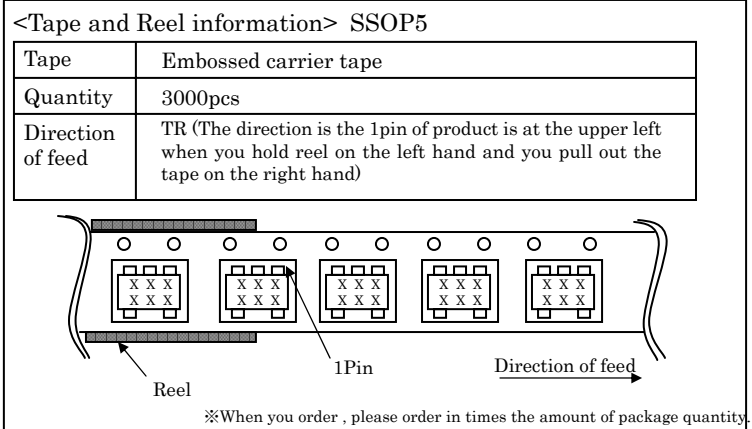
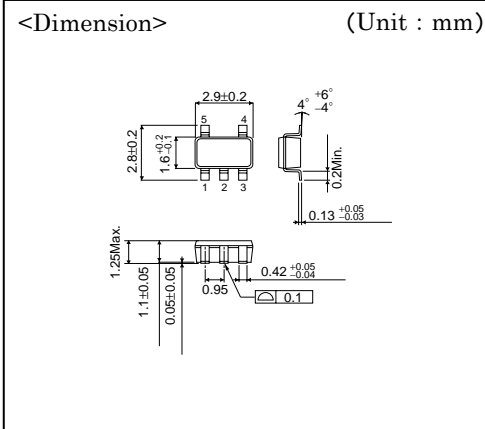

- The contents described herein are correct as of October, 2005
- The contents described herein are subject to change without notice. For updates of the latest information, please contact and confirm with ROHM CO.,LTD.
- Any part of this application note must not be duplicated or copied without our permission.
- Application circuit diagrams and circuit constants contained herein are shown as examples of standard use and operation. Please pay careful attention to the peripheral conditions when designing circuits and deciding upon circuit constants in the set.
- Any data, including, but not limited to application circuit diagrams and information, described herein are intended only as illustrations of such devices and not as the specifications for such devices. ROHM CO.,LTD. disclaims any warranty that any use of such devices shall be free from infringement of any third party's intellectual property rights or other proprietary rights, and further, assumes no liability of whatsoever nature in the event of any such infringement, or arising from or connected with or related to the use of such devices.
- Upon the sale of any such devices, other than for buyer's right to use such devices itself, resell or otherwise dispose of the same, implied right or license to practice or commercially exploit any intellectual property rights or other proprietary rights owned or controlled by ROHM CO., LTD. is granted to any such buyer.
- The products described herein utilize silicon as the main material.
- The products described herein are not designed to be X ray proof.

The products listed in this catalog are designed to be used with ordinary electronic equipment or devices (such as audio visual equipment, office-automation equipment, communications devices, electrical appliances and electronic toys). Should you intend to use these products with equipment or devices which require an extremely high level of reliability and the malfunction of which would directly endanger human life (such as medical instruments, transportation equipment, aerospace machinery, nuclear-reactor controllers, fuel controllers and other safety devices), please be sure to consult with our sales representative in advance.

Excellence in Electronics



ROHM CO., LTD.

21, Saiin Mizosaki-cho, Ukyo-ku, Kyoto
 615-8585, Japan
 TEL: (075)311-2121 FAX: (075)315-0172
 URL <http://www.rohm.com>

Published by
 Application Engineering Group

Contact us for further information about the products.

Atlanta U.S.A. / ROHM ELECTRONICS ATLANTA SALES OFFICE
 (DIVISION OF ROHM ELE.U.S.A.,LLC)
 TEL:+1(770)754-5972 FAX:+1(770)754-0691

Dallas U.S.A. / ROHM ELECTRONICS DALLAS SALES OFFICE
 (DIVISION OF ROHM ELE.U.S.A.,LLC)
 TEL:+1(972)312-8818 FAX:+1(972)312-0330

San Diego U.S.A. / ROHM ELECTRONICS SAN DIEGO SALES OFFICE
 (DIVISION OF ROHM ELE.U.S.A.,LLC)
 TEL:+1(858)625-3630 FAX:+1(858)625-3670

Germany / ROHM ELECTRONICS GMBH (GERMANY)
 TEL:+49(2154)9210 FAX:+49(2154)921400

United Kingdom / ROHM ELECTRONICS GMBH (UK)
 TEL:+44(0)1908-306700 FAX:+44(0)1908-235788

France / ROHM ELECTRONICS GMBH (FRANCE)
 TEL:+33(0)1 56 97 30 60 FAX:+33(0)1 56 97 30 80

Hong Kong China / ROHM ELECTRONICS (HK.) CO., LTD.
 TEL:+852(2)7406262 FAX:+852(2)375-8971

Shanghai China / ROHM ELECTRONICS (SHANGHAI) CO., LTD.
 TEL:+86(21)6279-2727 FAX:+86(21)6247-2066

Dalian China / ROHM ELECTRONICS TRADING (DALIAN) CO., LTD.
 TEL:+86(411)8230-8549 FAX:+86(411)8230-8537

Beijing China / BEIJING REPRESENTATIVE OFFICE
 TEL:+86(10)8525-2483 FAX:+86(10)8525-2489

Taiwan / ROHM ELECTRONICS TAIWAN CO., LTD.
 TEL:+886(2)2500-8956 FAX:+886(2)2503-2669

Korea / ROHM ELECTRONICS KOREA CORPORATION
 TEL:+82(2)8182-700 FAX:+82(2)8182-715

Singapore / ROHM ELECTRONICS ASIA PTE.LTD. (RES./REI)
 TEL:+65-6332-2322 FAX:+65-6332-5662

Malaysia / ROHM ELECTRONICS (MALAYSIA) SDN. BHD.
 TEL:+60(3)7353-8355 FAX:+60(3)7359-8377

Philippines / ROHM ELECTRONICS (PHILIPPINES) SALES CORPORATION
 TEL:+63(2)807-6872 FAX:+63(2)809-1422

Thailand / ROHM ELECTRONICS (THAILAND) CO., LTD.
 TEL:+66(2)254-4890 FAX:+66(2)256-6334

Notes

- No technical content pages of this document may be reproduced in any form or transmitted by any means without prior permission of ROHM CO.,LTD.
- The contents described herein are subject to change without notice. The specifications for the product described in this document are for reference only. Upon actual use, therefore, please request that specifications to be separately delivered.
- Application circuit diagrams and circuit constants contained herein are shown as examples of standard use and operation. Please pay careful attention to the peripheral conditions when designing circuits and deciding upon circuit constants in the set.
- Any data, including, but not limited to application circuit diagrams information, described herein are intended only as illustrations of such devices and not as the specifications for such devices. ROHM CO.,LTD. disclaims any warranty that any use of such devices shall be free from infringement of any third party's intellectual property rights or other proprietary rights, and further, assumes no liability of whatsoever nature in the event of any such infringement, or arising from or connected with or related to the use of such devices.
- Upon the sale of any such devices, other than for buyer's right to use such devices itself, resell or otherwise dispose of the same, no express or implied right or license to practice or commercially exploit any intellectual property rights or other proprietary rights owned or controlled by
- ROHM CO., LTD. is granted to any such buyer.
- Products listed in this document are no antiradiation design.

The products listed in this document are designed to be used with ordinary electronic equipment or devices (such as audio visual equipment, office-automation equipment, communications devices, electrical appliances and electronic toys).

Should you intend to use these products with equipment or devices which require an extremely high level of reliability and the malfunction of which would directly endanger human life (such as medical instruments, transportation equipment, aerospace machinery, nuclear-reactor controllers, fuel controllers and other safety devices), please be sure to consult with our sales representative in advance.

It is our top priority to supply products with the utmost quality and reliability. However, there is always a chance of failure due to unexpected factors. Therefore, please take into account the derating characteristics and allow for sufficient safety features, such as extra margin, anti-flammability, and fail-safe measures when designing in order to prevent possible accidents that may result in bodily harm or fire caused by component failure. ROHM cannot be held responsible for any damages arising from the use of the products under conditions out of the range of the specifications or due to non-compliance with the NOTES specified in this catalog.

Thank you for your accessing to ROHM product informations.

More detail product informations and catalogs are available, please contact your nearest sales office.

ROHM Customer Support System

THE AMERICAS / EUROPE / ASIA / JAPAN

www.rohm.com

Contact us : webmaster@rohm.co.jp