

4-channel BTL driver for CD players

AM1469 V33/V50

The AM1469 is a 4-channel BTL driver for CD player motors and actuators. An internal 3.3V/5.0V regulator and standard op amp are provided for variety of applications.

● Applications

1. CD player
2. VCD player
3. DVD player

● Features

- | | |
|---|--|
| 1) HSOP28 package with good thermal performance | 4) V33 -- 3.3V regulator.
V50 -- 5.0V regulator
(requires attached PNP transistor) |
| 2) Few external parts. | 5) Internal standard operational amplifier. |
| 3) External resistor allows gain adjustment. | 6) Built-in thermal shutdown circuit. |

● Absolute maximum ratings (Ta = 25 °C)

Parameter	Symbol	Rating	Unit
Power supply voltage	V _{CC} max.	13.5	V
Power dissipation	P _d	1.7* ¹	W
Storage temperature	T _{stg}	-55~+150	

* 1 Use base condition : 100x100mm, t=1.6mm, copper leaf 50%, glass epoxy mounting.
Derating is done at 13.6mW/°C for operation above Ta = 25 °C.

● Recommended operating conditions (Ta = 25 °C)

Parameter	Symbol	Limits	Unit
Operating temperature	T _{OPR}	-25 ~ +85	
Operational voltage	V _{OPR}	5 ~ 12	V

● Block diagram

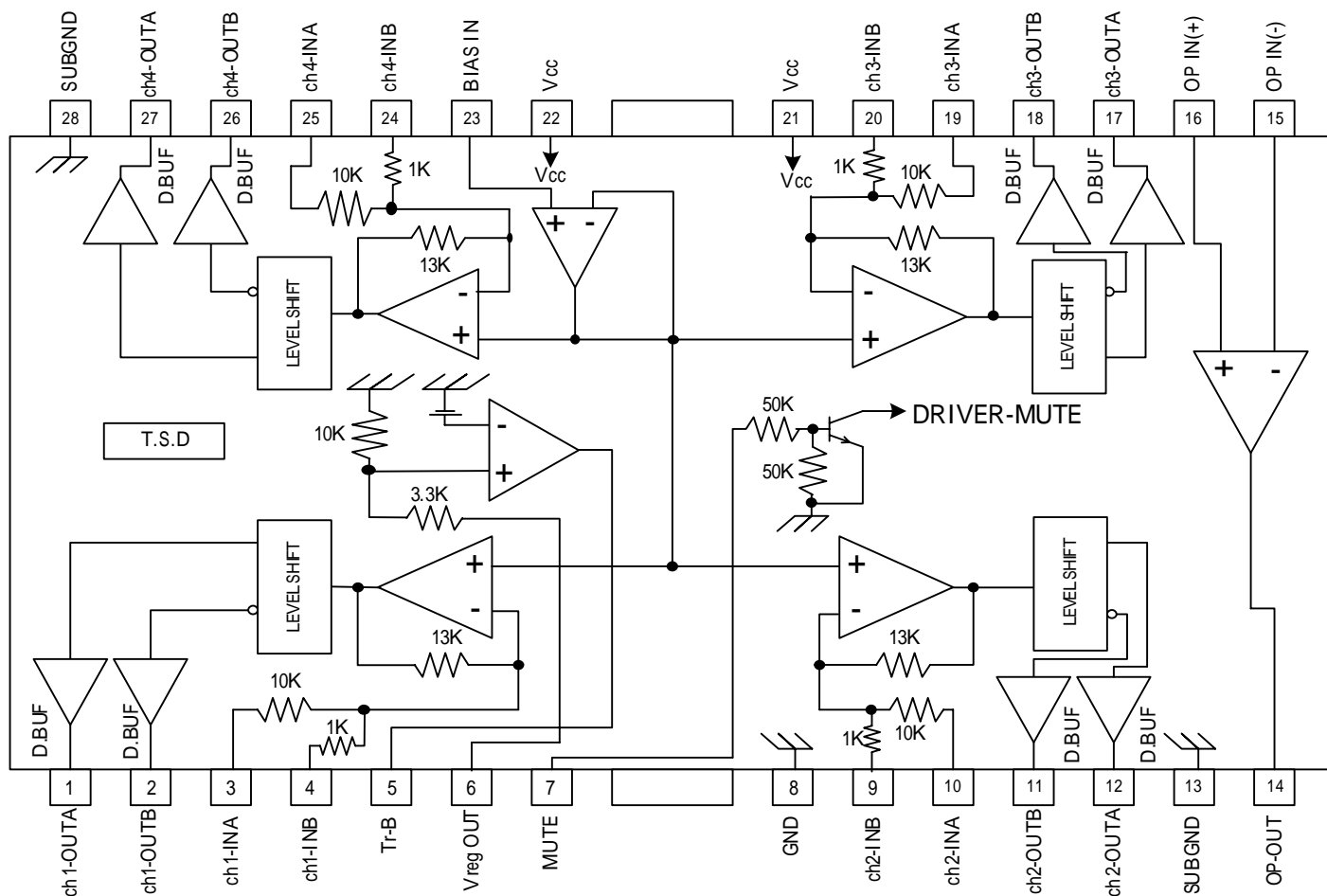

TSD : Thermal shutdown circuit
D.Buf : Drive buffer

● Pin configuration

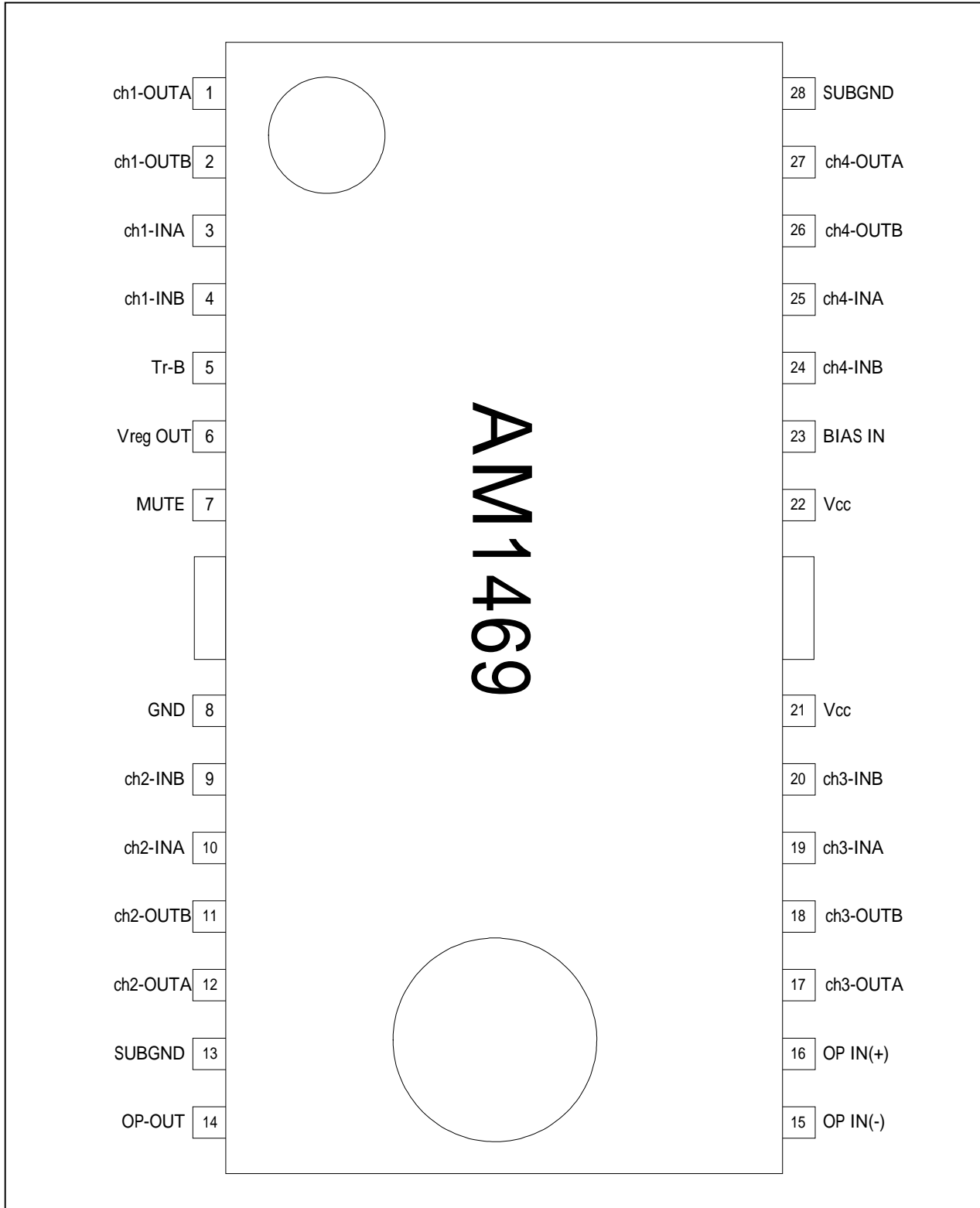

● **Pin descriptions**

Pin No.	Pin name	Function
1	ch1-OUT A	Driver channel 1 negative output
2	ch1-OUT B	Driver channel 1 positive output
3	ch1-IN A	Driver channel 1 input
4	ch1-IN B	Driver channel 1 input, gain adjustment pin
5	Tr-B	Connect to external transistor base
6	Vreg OUT	Constant voltage output, connects to external transistor collector
7	MUTE	Driver mute control input
8	GND	Ground
9	ch2-IN B	Driver channel 2 input, gain adjustment pin
10	ch2-IN A	Driver channel 2 input
11	ch2-OUT B	Driver channel 2 positive output
12	ch2-OUT A	Driver channel 2 negative output
13	SUBGND	Substrate ground
14	OP OUT	Operational amplifier output
15	OP IN(-)	Operational amplifier negative input
16	OP IN(+)	Operational amplifier positive input
17	ch3-OUT A	Driver channel 3 negative output
18	ch3-OUT B	Driver channel 3 positive output
19	ch3-IN A	Driver channel 3 input
20	ch3-IN B	Driver channel 3 input, gain adjustment pin
21	Vcc	Power supply
22	Vcc	Power supply
23	BIAS IN	Bias amplifier input pin
24	ch4-IN B	Driver channel 4 input, gain adjustment pin
25	ch4-IN A	Driver channel 4 input
26	ch4-OUT B	Driver channel 4 positive output
27	ch4-OUT A	Driver channel 4 negative output
28	SUBGND	Substrate ground

Note : Positive and negative output is relative to the polarity of the input pins.

● **Electrical characteristics** (unless otherwise noted, $T_a = 25$, $V_{cc} = 8V$, $f = 1kHz$)

Parameter	Symbol	Min	Typ.	Max	Unit	Conditions
Quiescent current dissipation	I_{cc}	5.5	8.0	10.5	mA	No load
Output voltage offset	V_{OO}	-40	-	40	mV	
Maximum output high level voltage	V_{OHD}	5.2	5.6	-	V	
Maximum output low level voltage	V_{OLD}	-	1.3	1.55	V	
Closed loop voltage gain	G_{VC}	7.0	8.0	9.0	dB	$V_{IN}=0.1V_{rms}$, $f = 1kHz$
Ripple rejection ratio	RR	-	60	-	dB	$V_{IN}=0.1V_{rms}$, $f = 100Hz$
Slew rate	SR	-	2.0	-	V/ μ S	$f=100kHz$, $V_{OUT}=4V_{P-P}$ square wave
Mute Off voltage	V_{MOFF}	2.0	-	-	V	
<3.3 V/ 5.0 V regulator>						
Output voltage	V_{reg}	3.1	3.3	3.5	V	$I_L=100mA$
		4.75	5.00	5.25		
Output load differential	ΔV_{RL}	-50	0	10	mV	$I_L=0\sim 200mA$
Power supply voltage differential	ΔV_{VCC}	-10	0	25	mV	$(V_{cc}=6\sim 9V)$ $I_L=100mA$
<Operational amplifier>						
Offset voltage	V_{OFOP}	-2	0	2	mV	
Input bias current	I_{BOP}	-	20	300	nA	
Output high level voltage	V_{OHOP}	6.0	-	-	V	
Output low level voltage	V_{OLOP}	-	-	1.8	V	
Output drive current (sink)	I_{SINK}	10	50	-	mA	V_{cc} at 50Ω
Output drive current (source)	I_{SOURCE}	10	30	-	mA	50Ω at ground
Open loop voltage gain	G_{VO}	-	78	-	dB	$V_{IN}=75dBV$, $f = 1kHz$
Slew rate	SR_{OP}	-	1	-	V/ μ S	$f=100kHz$, $V_{OUT}=4V_{P-P}$ square wave
Ripple rejection ratio	RR_{OP}	-	65	-	dB	$V_{IN}=-20dBV$, $f = 100Hz$
Common mode rejection ratio	CMRR	70	84	-	dB	$V_{IN}=-20dBV$, $f = 1kHz$

Not designed for radiation resistance

● Measuring Circuit

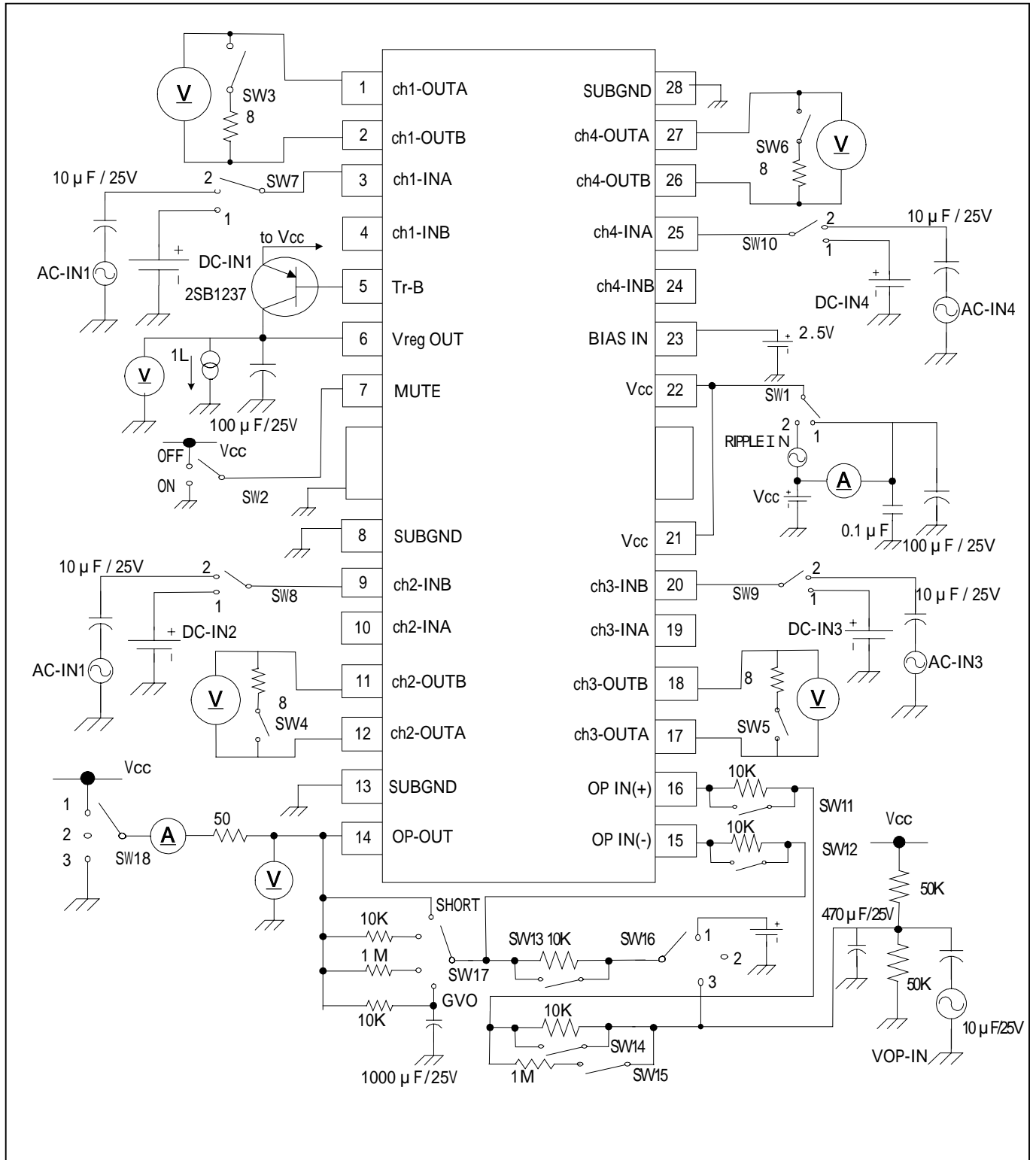

● Application Circuit

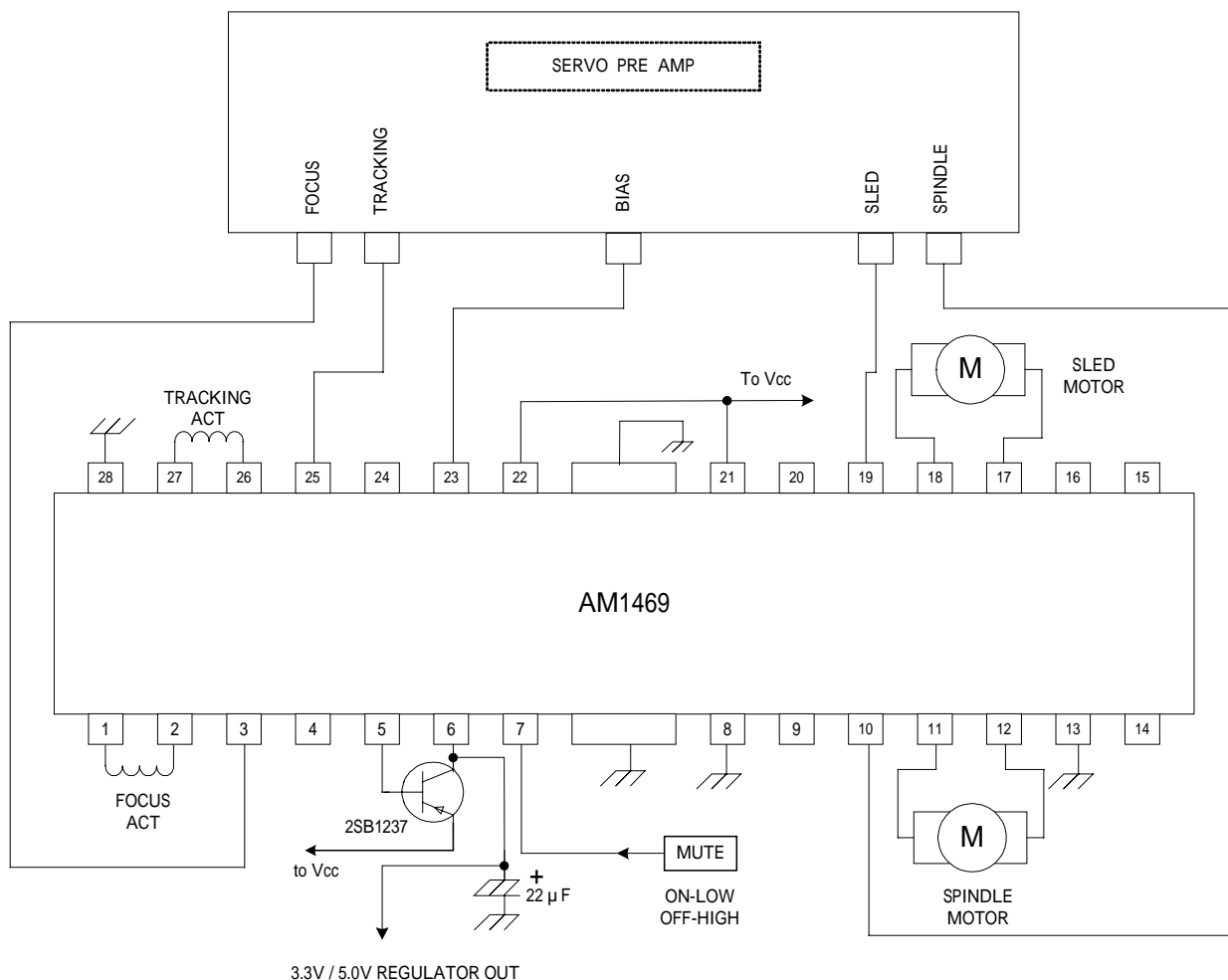

● Operation notes

- (1) A thermal shutdown circuit is built. Output current is muted when the chip reaches 175 typ..
- (2) If the mute pin (pin 7) voltage is opened or is less than 0.5V, the output current is muted. Pin 7 should be pulled up above 2.0V during normal use.
- (3) The bias pin (pin 23) is muted when lowered below 1.2V (typically). Make sure it stays above 1.6V during normal use.
- (4) The drivers are turned OFF when the supply voltage drops below 4.5V typ. When the voltage rises above 4.7V typ., the drivers return to their previous state
- (5) Muting occurs during thermal shutdown, mute-on, bias pin voltage drop. Other sections are not muted. When muted, the internal bias voltage of the output pin becomes (roughly $(V_{cc}-V_f)/2$).
- (6) The internal input resistor has a positive temperature coefficient of 2,100ppm/. When changing the gain using an external resistance, the gain will change as the temperature of the resistor changes. When using the internal input resistance, there are virtually no gain variation due to temperature.
- (7) Heat dissipation fins are attached to the GND on the inside of package. Make sure to connect these to the external GND-plane.
- (8) The capacitor between regulator output (pin 6) and GND also serves to stop oscillation of the IC circuit. Consequently, make sure to use one with good temperature characteristics.

● External dimensions (Units: mm)

